

EF 40C1

EFFUSION CELL

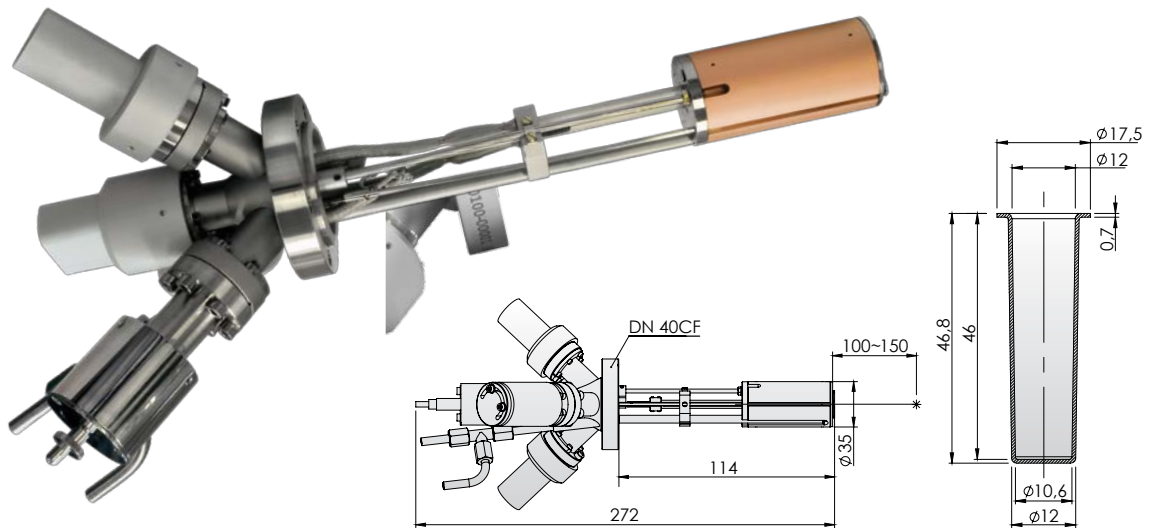

DESCRIPTION

EF 40C1 Effusion Cell (Knudsen Cell) is a source designed for delivering highly constant evaporation rates by indirect resistive heating at the material. Custom insertion length 114 - 380 mm (other on request).

FEATURES

- Extremely stable flux rates
- Various crucible materials
- Highly reproducible & reliable
- Suitable for use in any MBE system
- No free construction (allows high outgassing temperatures)
- Integral water cooling

OPTIONS

- Customised insertion length
- With or without integrated manual/electro-pneumatic shutter
- Linear shift
- Crucibles
- Thermocouple type K

HEATING CONTROL APPLICATION

- With or without integrated manual/electro-pneumatic shutter
- Linear shift
- Crucibles

TECHNICAL DATA

Mounting flange	DN 40 CF (rotatable)
Heater	W wire (tungsten)
Temperature range	EF 1500 °C (~250 °C - 1500 °C, 1600 °C for degas) EF 1200 °C (~250 °C - 1200 °C)
Temperature stability	± 0.1 °C
Crucible type (option)	PBN, Al ₂ O ₃ , Quartz (other materials on request)
Crucibles volume	5cc
Evaporated materials	all typical materials according to crucible type
Thermocouple type	EF 1500 °C - type C (standard) EF 1200 °C - type K (option)
Degassing temp.	1600 °C
Type of shutter	side or flip type, manual or pneumatic
Water cooling (required)	water flow > 0.5 l/min temperature: 20 - 30 °C max pressure: 6 bar
Insertion length	min. 114 mm (other on request) OD: 35 mm
Deposition area	dependent on working distance
Working distance	100 - 150 mm
Bakeout temperature	up to 250 °C
Working pressure	< 10 ⁻⁵ mbar



PREVAC sp. z o.o. sales@prevac.eu
Raciborska Str. 61 [+48 32 459 21 30](tel:+48324592130)
PL44362 Rogów [+48 32 459 20 01](tel:+48324592001)

EF 40C1

HEAT3-PS

SAMPLE HEATING POWER SUPPLY

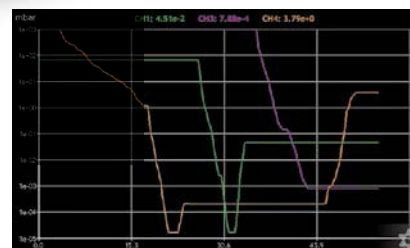

Real time pressure charts (data export possibility).

DESCRIPTION

The HEAT3-PS is used for resistive heating or electron bombardment heating. The power supply can also be used for effusion cell evaporators. The unit is equipped with a PID temperature controller. Ramp heating function control sample temperature to protect sample from damage. Sample overheating can also be protected by setting the voltage and current limits. The unit can be operated in auto mode (with temperature control) or manual mode (without temperature control). The unit is equipped with autosave function (the device save your parameters, preset and apply them automatically after restart).

FEATURES

- **Dual heating mode: resistive** and **electron bombardment**
- Wide range temperature measurement (1.4 - 2473.15 K)
- **2D real time chart module**
- High efficiency
- Setpoint based over-voltage and over-current output protection
- Fully manual or PID temperature controlled (by setpoint and ramp)
- Process temperature control with built-in PID controller (with autotuning function for optimized process PID parameters)
- Various kind of temperature sensors: thermocouples K/C/E/N (other on request), Pt, diode
- Multiple I/O (10 digital/4 analog) - individual reprogrammable
- High resolution (16-bit analog I/O, 0.1 K temp.)
- One vacuum channel for active gauges
- **Shutter control function** - up to 2* shutters (e.g. shutters of sources or manipulators)
- Mobile solutions for remote access and control
- Customised menu options (for robust and effectivity)
- Support (easy firmware update via USB)

* for double DC module version, 1 shutter per channel

OPTIONS

- **Second DC module** available: **two resistive heating zones** with independent control, or one resistive heating zone with **higher output power** (90V, 17A or 45V, 30A) excluding EB module
- Analog I/O card for vacuum measurement (1 gauge)

TECHNICAL DATA

Supply voltage	100-130VAC/200-260 VAC, 50-60Hz (power consumption max 1600 W)
Resistive heating mode parameters	45 V, 17 A - standard; other versions on request
EB heating mode parameters	1000 V, 300 mA - standard; other versions on request
Temperature range	• 273.15 K - 2473.15 K for type C thermocouple (dependent on sample holder type or evaporator) • 73.15 K - 1645.15 K for type K thermocouple • 1.4 K - 500 K for DT670/DT470 silicon diodes (dependent on sample holder type and conditions in chamber)
Temperature independent inputs	2 - for thermocouples K/C/E/N 2 - for silicon diodes DT670/DT470
Temperature setpoint ramp rate	adjustable from 0.1 K to 1000 K/s min h
ΔT setpoint	0.1 to 5.0 K/s
Vacuum measurement (optional)	CTR90, TTR91, TTR211, PTR225, PTR90, ITR90, ITR100, Baratron, ANALOG IN, PG105, MG13/14, PKR251/360/361, PCR280, ATMION
Communication interface	RS232/485, Ethernet
Communication protocol	MODBUS-TCP
User interface	7" TFT display with touchscreen, digital encoder
Interface languages	English, German, Polish
Dimensions	448.8 × 132.5 × 375 mm (W×H×D), 19" rack mountable
Weight (approx.)	8.8 kg (for standard version)

APPLICATION

- Any thermal process according to the specifications
- Effusion cells supply
- Sample holders heating
- Thermal monitoring



PREVAC sp. z o.o. sales@prevac.eu
Raciborska Str. 61 [+48 32 459 21 30](tel:+48324592130)
PL44362 Rogów [+48 32 459 20 01](tel:+48324592001)

HEAT3-PS