

VB215

Double Column Bridge
Vertical Machining Center
Specifications



*All specifications are subject to change without prior notice
Verification of technical changes may be confirmed after receipt of order*

Designed and built by Wele Mechatronic in Taiwan, this machining center is sold and serviced exclusively by JTEKT Toyota Americas Corporation and our exclusive representatives.

Machine Specifications

X Axis Travel	2,020 mm (79.5")
Y Axis Travel	1,500 mm (59")
Z Axis Travel	800 mm (31.5")
Distance from Spindle Nose to Table Top	200 - 1,000 mm (7.9" - 39.4")
Distance between Columns	1,600 mm (62.9")
Table Size (X Direction)	2,100 mm (82.6")
Table Size (Y Direction)	1,400 mm (55.1")
Table Load Capacity	8,000 kg (17,600 lb)
Table T-Slot Size - Width x Distance x Number	22 x 155.5 mm x 9 (.866" x 6.12" x 9)
Table Height From Plant Floor	890 mm (35.0")
Spindle Taper	BCV50
Spindle Motor (Cont. / 30 Min. Rating)	22 / 26 kW (30 / 35 hp)
Spindle Speed	10 ~ 6,000 min ⁻¹
Maximum Torque at Spindle 100% Duty	626.2 Nm (461 ft-lb)
Spindle Bearing Diameter	100 mm (3.9")
Spindle Type	Two Steps Geared
Rapid Feedrate (X Axes)	24 m/min (944 ipm)
Rapid Feedrate (Y Axis)	24 m/min (944 ipm)
Rapid Feedrate (Z Axis)	15 m/min (590 ipm)
Maximum Cutting Feedrate	10 m/min (394 ipm)
Tool Magazine Capacity	32

Machine Specifications (Continued)

Maximum Tool Diameter / Adjacent Pocket Empty	127 / 215 mm (5.0" / 8.5")
Maximum Tool Length	400 mm (15.7")
Maximum Tool Weight	20 kg (44.1 lb)
Tool Taper	CAT 50
Pull Stud	ANSI CAT50
Tool Selection	Random
Tool Access	Bi-Directional
Positioning Accuracy (X, Y Axes) per JIS-B6338-1985	± 0.015 / (± 0.0006" / Full Travel
Positioning Accuracy (Z Axis) per JIS-B6338-1985	± 0.015 / (± 0.0006" / Full Travel
Repeatability (All Axes) per JIS-B6338-1985	± 0.003 (± 0.0001")
Total Power Required	AC 220 V ±10% (70 kVA)
Air Resource	90 Psi @ 3.78 CFM
Power Supply Frequency	60 Hz
Control Voltage	24 Volt
Control Type	Fanuc OiMF-Plus
Axis Guideways	Linear Roller Guideway
Machine Weight (estimated)	20,000 kg (44,000 lb)
Machine Length *	8,058 mm (317.2")
Machine Width *	4,550 mm (179.1")
Machine Height *	4,128 mm (162.5")
*Dimensions include Operator Control, Coolant Tank, Chip Conveyor and Std. ATC, all are approximate	
Coolant Tank Capacity	106 gal
Flood Coolant (Gallons per Minute)	20 gal

Note: Machine is 220V / 3 Phase / 60 Hz. Any other voltage requires a transformer (not supplied as std.)

* Dimensions are approximate, please verify upon ordering

Machine Options (Factory Ordered)

Sixty (60) Tool Capacity Magazine

Linear Scale Feedback System on X, Y and Z Axes

Machine Options (Field Retrofittable)

PCB Fast Ethernet/Data Server, 1 Gig Memory Card, Operator's Manual, Ethernet Function Software, Fast Data Server Function Software, Installation by Fanuc Technician after Completion of Initial Machine Installation.

Multi Step Skip Function (Required when more than one of the following; Spindle Probe, Tool Measurement System is ordered)

Canadian & Ontario Electrical & Safety Codes (ESA & PHSR) Toyoda will schedule a licensed Professional Engineering firm to inspect the equipment and submit a report defining any and all issues of regulatory non-compliance. Based on these findings, JTEKT Toyoda Americas Corporation will review all issues and submit a quotation for full compliance to ESA & PHSR regulations. The customer has the option of contracting JTAC (additional PO required), using a 3rd party electrical contractor or performing the work themselves. (Per machine/model/ site visit. VMC & Grinder Product line only)

Local Municipality Electrical Code Preparation Inspection Only
 Toyoda will schedule a licensed Professional Engineering firm to inspect the equipment and submit a report defining any and all issues of regulatory non-compliance. Based on these findings, JTEKT Toyoda Americas Corporation will review all issues and submit a quotation for full compliance to the MEC. The customer has the option of contracting JTAC (additional PO required), using a 3rd party electrical contractor or performing the work themselves. (Per machine/model/ site visit. All product lines)

** Customers opting not to purchase this service from Toyoda assume the responsibility of inspection & compliance to any Federal, State, Provincial or Local Electrical and Safety regulations.*

Fanuc OiMF Plus control specification		
No	Function	Specifications
1. System Functions		
1.1	Color LCD/MDI	
1.2	Control axes	4 axes (Option to 5 axes)
1.3	Simultaneously controlled axes	4 axes
1.4	Spindle axes	1 axes
1.5	Memory card interface	CF card and PCMCIA card attachment is required. Program operation on large capacity memory Function (for DNC)
1.6	Ethernet interface	Program transfer
1.7	RS-232C interface	
1.8	USB interface	Only data input and output (not DNC)
2. Axis functions		
2.1	High-speed and high-precision machining	HRV3 Control
2.2	Follow up	
2.3	Overtravel	
2.4	Software stroke check 1	
2.5	Software stroke check 2, 3	
2.6	Stroke check before movement	
2.7	Control axis detach	
3. Spindle functions		
3.1	Spindle orientation	M19
3.2	Rigid tapping	M29
3.3	FSSB High speed rigid tapping	
3.4	Constant surface speed control	
3.5	Spindle serial output	
3.6	Spindle output switching function	
3.7	Spindle synchronous control	
4. Operation functions		
4.1	Machine lock	All axes
4.2	Z lock	
4.3	Emergency stop	

Fanuc OiMF Plus control specification

4.4	Single block	
4.5	MDI Operation	
4.6	Manual handle feed	1 unit
4.7	Manual handle feed rate	X1, X10, X100
4.8	Handle interruption	
4.9	Dry run	
4.10	Program restart	
4.11	Playback	
4.12	JOG feed	
4.13	Manual reference position return	
4.14	Rapid traverse override	F0, 25%, 50%, 100%
4.15	Cutting feedrate override	0, 10%, 20%, 30%, ... 200%
4.16	Spindle override	50%, 60%, 70%, ... 120%
4.17	Optional block skip	
4.18	Direct input of workpiece origin offset value measured	
4.19	Manual absolute on and off	
4.20	Program protect key	
4.21	Help function	
4.22	Self-diagnosis function	
5. Editing functions		
5.1	Increment system C	0.001mm / 0.0001 inch / 0.001 deg
5.2	Backlash compensation	
5.3	DNC operation	CF card or RS-232C or Data Server attachment is required
5.4	Positioning	G00
5.5	Linear interpolation	G01
5.6	Circular interpolation cw(ccw) Helical interpolation cw(ccw)	G02, G03
5.7	Dwell, exact stop	G04
5.8	Exact stop	G09
5.9	Programmable data input	G10, G11
5.10	Polar coordinate command	G15, G16

Fanuc OiMF Plus control specification

5.11	Plane selection	G17, G18, G19
5.12	Input in mm or inch	G20, G21
5.13	Automatic return to reference position	G28
5.14	Skip function	G31
5.15	Thread cutting	G33 (macro control is required)
5.16	Special fixed cycle	G34, G35 (macro control is required)
5.17	Cutter compensation	G40, G41, G42
5.18	Tool offset increase or decrease	G45~G59
5.19	Workpiece coordinate system	G54~G59
5.20	Addition of Workpiece coordinate system	48 pairs
5.21	Programmable mirror image	G50.1 / G51.1
5.22	Scaling cancel	G50 / G51
5.23	Single direction position	G60
5.24	Exact stop mode	G61
5.25	Automatic corner override	G62
5.26	Coordinate system rotation mode	G68, G69
5.27	Peck drilling cycle	G73, G83
5.28	Fixed cycle	G74, G76, G80, G81, G84-G89
5.29	Absolute or incremental programming	G90, G91
5.30	Workpiece coordinate system preset	
5.31	Feed per minute	G94
5.32	Feed per revolution	G95
5.33	Custom macro	
5.34	Addition of Custom macro common variables	#100~#199, #500~#999
5.35	External deceleration	
5.36	Automatic corner deceleration	
5.37	Automatic acceleration/deceleration	linear
5.38	Rapid traverse bell-shaped acceleration/deceleration	
5.39	Bell-type acceleration/deceleration after cutting feed interpolation	
5.40	Helical interpolation	
5.41	AI contour control II	Look-ahead blocks 200
5.42	Program cide	EIA/ISO

Fanuc OiMF Plus control specification

5.43	Parity check	
5.44	Program file name	32 characters
5.45	Sequence number	N8 digit
5.46	Decimal point programming/pocket calculator type decimal point programming	
5.47	Rotary axis designation	
5.48	Optional chamfering/corner R	
5.49	Number of registerable programs	1000 programs
5.50	Part program storage size	2M byte
5.51	Part program editing	
5.52	Extended part program editing	
5.53	Feedrate override reset	
5.54	Max. programmable dimension	+/- 9 digits
5.55	Sub program call	10 folds nested
5.56	M, S, T function	
5.57	Program stop / Optional stop	M00, M01
5.58	Program end	M02, M30
5.59	Air blow on	M07
5.60	Auto power off	
5.61	Calling subprogram stored in external memory	M198
5.62	Tool function	T8 digit
5.63	Tool offset pairs	400 pairs
5.64	Tool offset memory C	
5.65	Tool length offset	
5.66	Tool radius offset	
5.67	Tool length measurement	
5.68	Tool life management	
5.69	Backlash compensation for each rapid traverse and cutting feed	
5.70	Stored pitch error compensation	
5.71	Alarm display	
5.72	Alarm history display	
5.73	Operator message display	
5.74	Operator message history display	

Fanuc OiMF Plus control specification

5.75	Run hour and parts count display	
5.76	Actual cutting feedrate display	
5.77	Status display	
5.78	Clock function	
5.79	Spindle speed function	
5.80	Servo setting screen	
5.81	Spindle setting screen	
5.82	Current position display	
5.83	Program comment display	Program name 31 characters
5.84	Parameter setting and display	
5.85	Multi-language display	
5.86	Dynamic display language switching	
5.87	Parameter setting support screen	
5.88	Display of hardware and software configuration	
5.89	Servo information screen	
5.90	Spindle information screen	
5.91	External machine zero point shift	
5.92	External message	
5.93	Screen hard copy	
5.94	Manual guide Oi	
5.95	Reference position return function	
5.96	Rigid tapping bell-shaped acceleration/deceleration	
5.97	Fine surface machining	
5.98	Macro executor/C language executor	
5.99	Dynamic graphic display	
6. Optional functions		
6.1	AI contour control II	Look-ahead blocks 400
6.2	Manual guide i	
6.3	Fast data Server	Suggest use item 1-5 (Program operation on large capacity memory function)
6.4	3-dimensional Coordinate systems conversion	

Included with this Model:

1. Color LCD Display
2. Chip Wash Down Coolant
3. Chip Wash Gun
4. Conversational FANUC Manual Guide i
5. Coolant System including tank & pumps
6. Plumbing for Coolant Through Spindle up to 70 bar (1000 PSI)
7. Dual Chip Auger Each Side of Table (Along X Axis)
8. Full Enclosure Splash Guard
9. 6,000 RPM, 35 hp Spindle Motor, Gear Driven, BCV#50 (Big Plus) Taper
10. Hand Tool Box
11. Helical Interpolation
12. Lift Up Type Hinged Belt Chip Conveyor (47" drop height)
13. Manual Pulse Generator (Hand Wheel)
14. Operation and Maintenance Manual, Fanuc Manuals
15. External Programmable Air Blast
16. Rigid Tapping
17. RJ-45 Ethernet
18. Spindle Oil Cooler
19. 32 Pocket ATC
20. Three (3) Tier Status / Alarm Lamp
21. Fixed & Adjustable Work Light

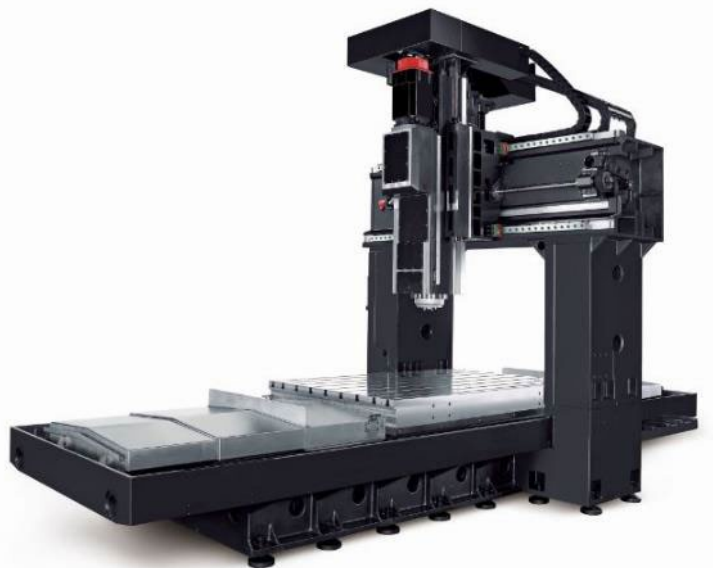

Spindles

Power& Torque BCV50 Geared Head

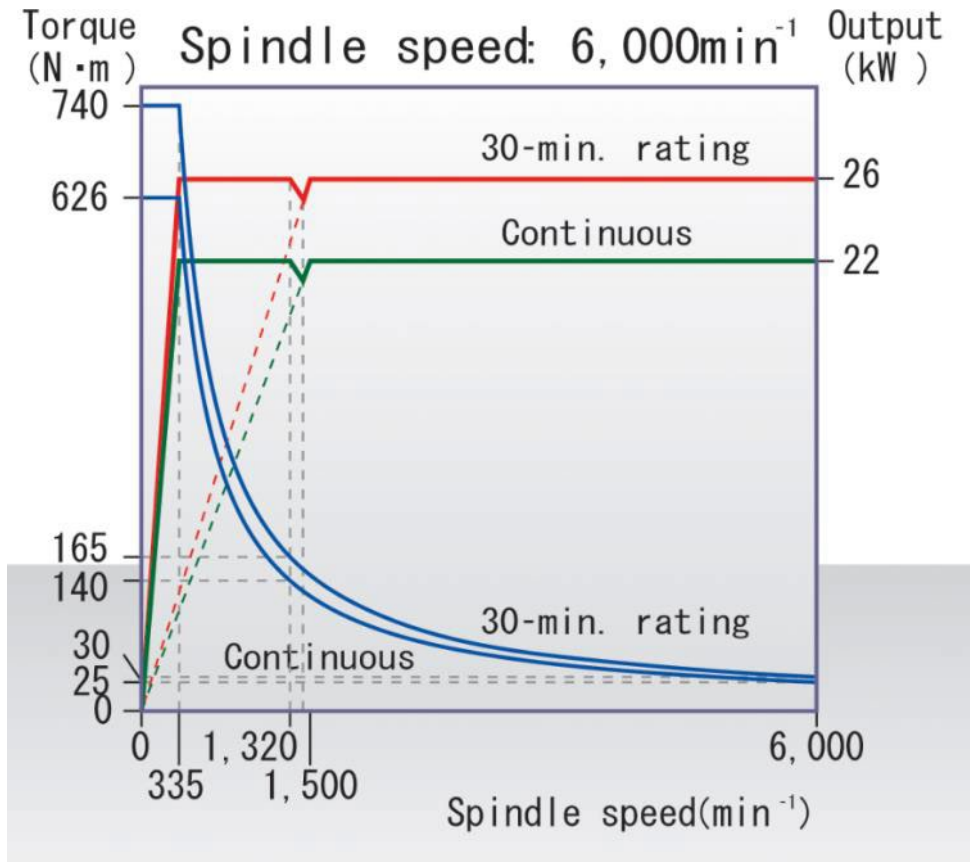

JTEKT Toyoda Americas Corp. recommends the use of only genuine BIG-PLUS® tooling (if applicable). The BIG-PLUS® system is licensed only to certain tool holder manufacturers, please verify the authenticity of any holders used in the spindle. Failure to use certified BIG-PLUS® certified tooling (if applicable) may void your warranty.

Work Envelope

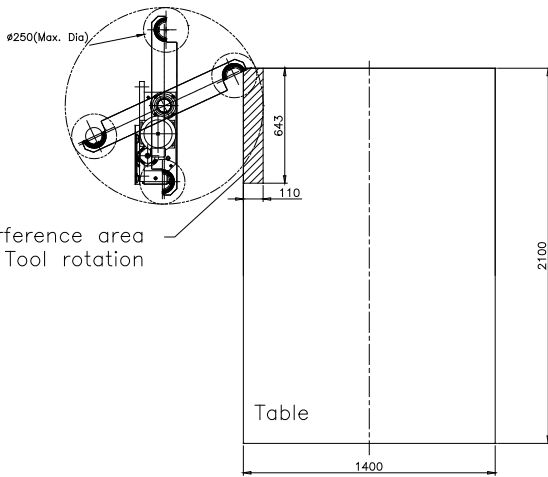
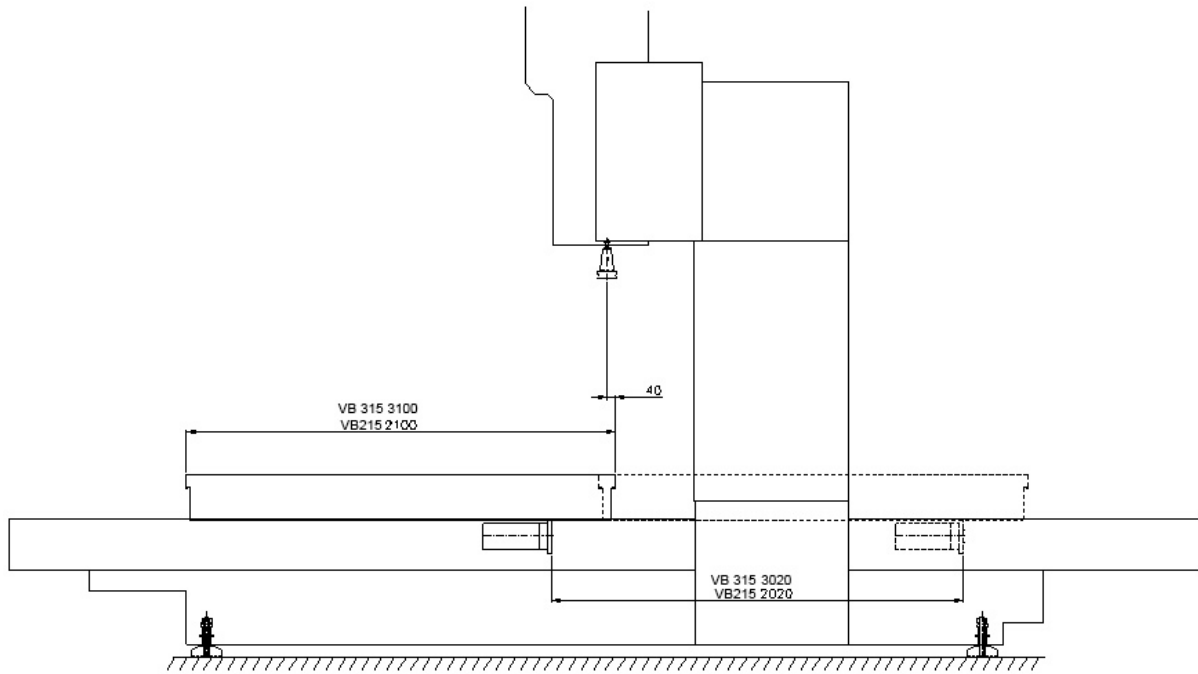

interference area of Tool exchange

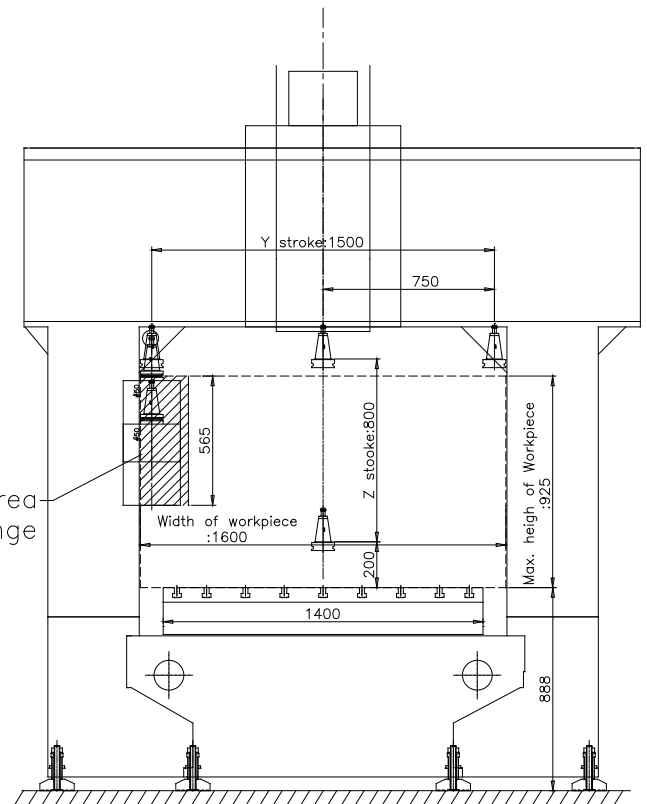

Table

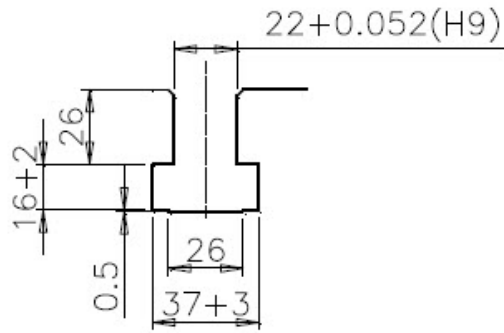
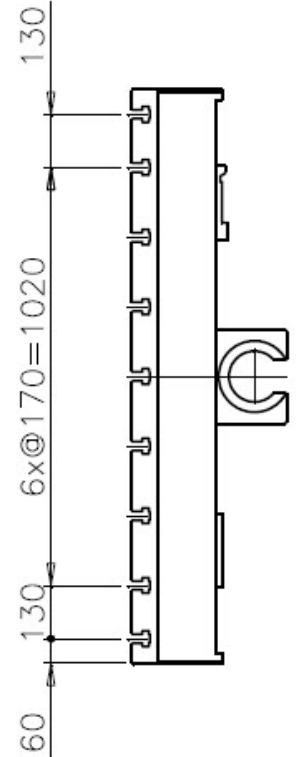

L	VB -215	VB -315
X	2100	3100

Machine Dimensions

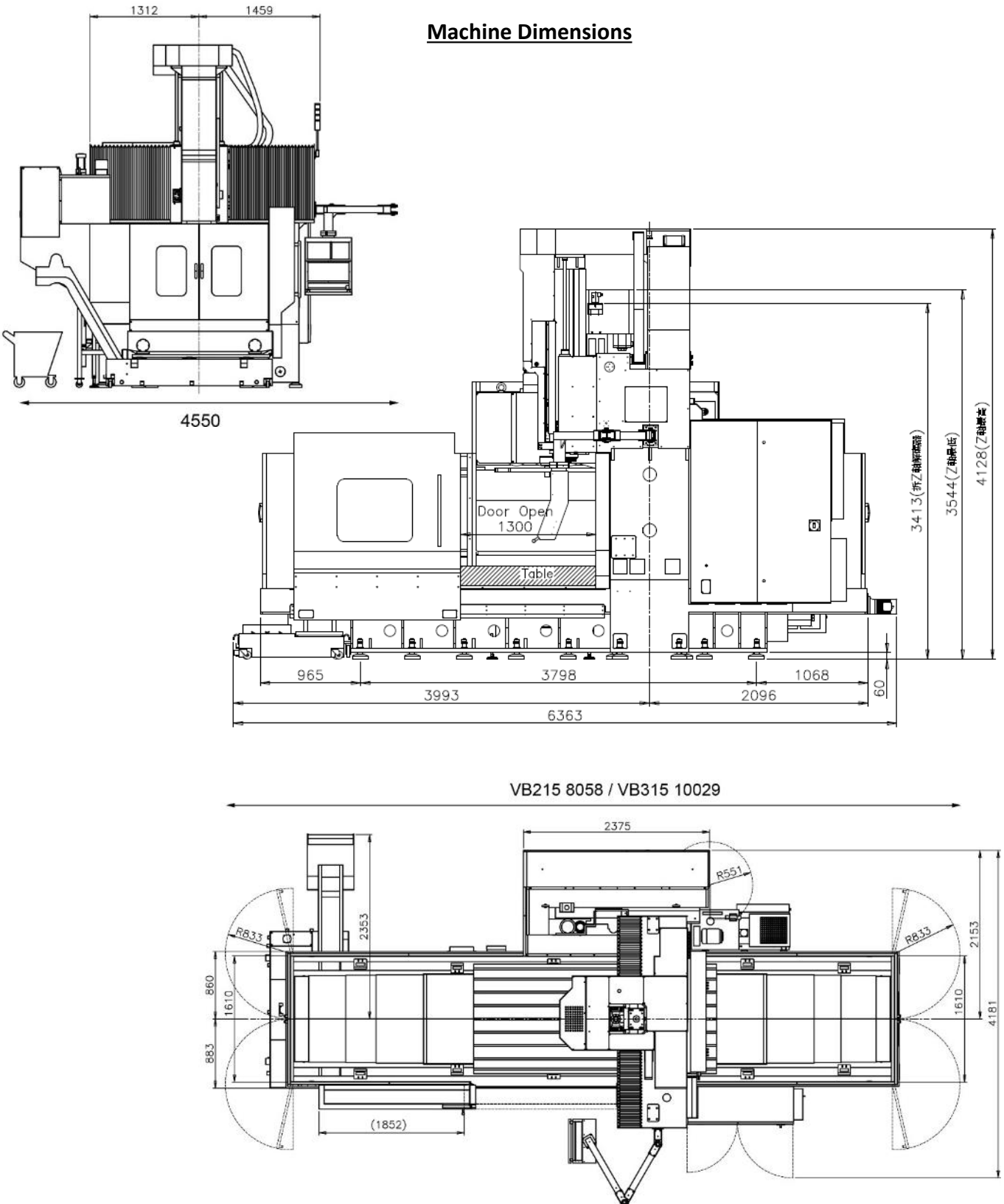

FOR REFERENCE ONLY: These dimensions are approximate. As specifications change often, please request a confirmed layout and foundation drawing prior to order placement.