



# NEX

NEX-108M  
NEX-108Y  
NEX-110M  
NEX-110Y



**CNC  
LATHE**

03



NEX-108M | NEX-108Y  
NEX-110M | NEX-110Y

06



Spindle output diagram

06



Spindle specifications



07



Turret specifications

**08**



Machine dimensions  
Working ranges  
Interference diagrams

**15**



NC unit specifications

**11**



Tooling system

**12**



Specifications

**13**



Standard and optional  
accessories



# NEX-108M | NEX-108Y NEX-110M | NEX-110Y

1. Modulized structure with optional C and Y axis.
2. The Takisawa in-house turret and spindle features high rigidity and accuracy with easy maintenance.
3. Minimum footprint, maximum working space.
4. High productivity to investment cost ratio.



## Specifications

### NEX-108M

Max. swing	18.9 Inch
Max. turning length	17.6 Inch
Max. turning diameter	10.2 Inch
Max. bar work capacity	2 Inch
Spindle speed	4000 rpm
Chuck size	8"

### NEX-108Y

Max. swing	18.9 Inch
Max. turning length	17.5 Inch
Max. turning diameter	10.2 Inch
Max. bar work capacity	2 Inch
Spindle speed	4000 rpm
Chuck size	8"

※ Specifications are subject to change without notice.



NEX-108M





## Specifications

### NEX-110M

Max. swing	22 Inch
Max. turning length	24.8 Inch
Max. turning diameter	13.8 Inch
Max. bar work capacity	3 Inch
Spindle speed	3500 rpm
Chuck size	10"

### NEX-110Y

Max. swing	22 Inch
Max. turning length	25 Inch
Max. turning diameter	13.8 Inch
Max. bar work capacity	3 Inch
Spindle speed	3500 rpm
Chuck size	10"

※ Specifications are subject to change without notice.

NEX-108M/NEX-108Y  
NEX-110M/NEX-110Y



NEX-110Y



NEX-110M



# NEX-108M | NEX-108Y | NEX-110M | NEX-110Y



The NEX series can be tailored for greatly improved productivity by incorporating a gantry loading arm for loading and unloading and an automated feeding system for raw materials and finished components.

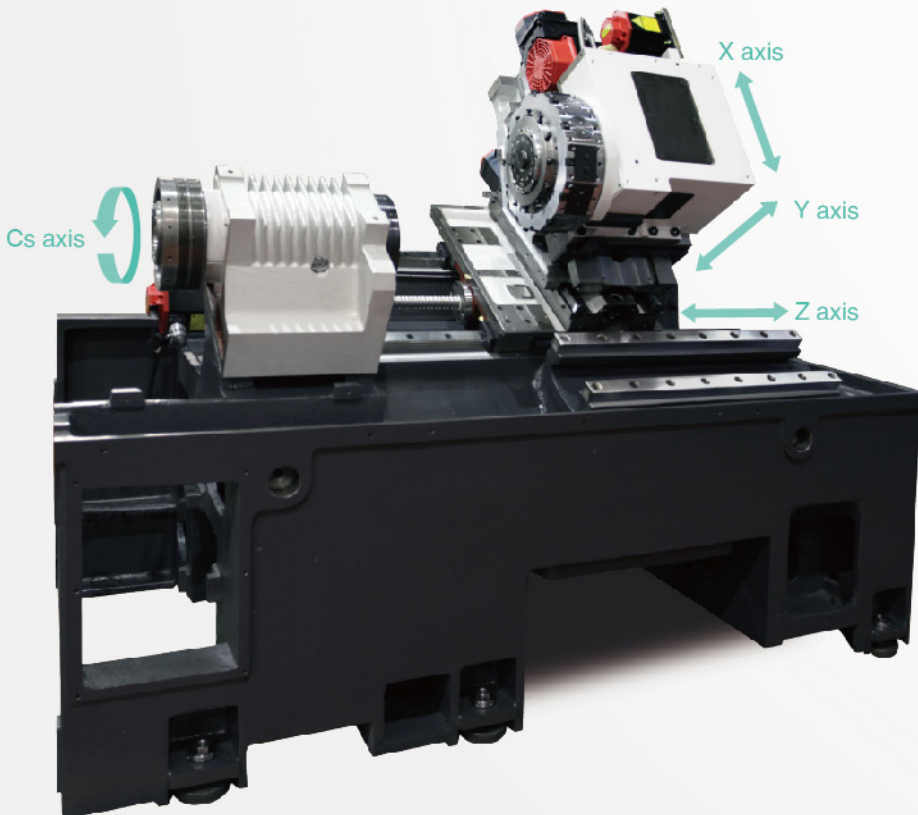
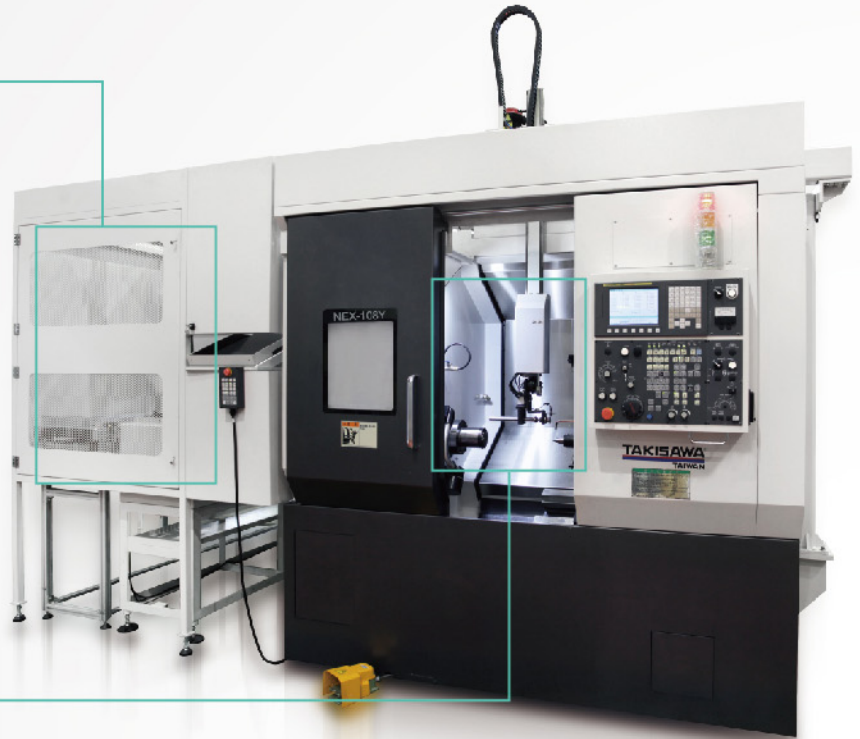

## Travel & Feedrate

### NEX-108M / NEX-108Y

X axis travel	7.1 / 7.7 Inch
X axis rapid traverse rate	787 ipm
Z axis travel	20.9 Inch
Z axis rapid traverse rate	945 ipm
Y axis travel	-- / ±1.6 Inch
Y axis rapid traverse rate	-- / 394 ipm

### NEX-110M / NEX-110Y

X axis travel	8.7 Inch
X axis rapid traverse rate	787 ipm
Z axis travel	28 Inch
Z axis rapid traverse rate	787 ipm
Y axis travel	-- / ±2 Inch
Y axis rapid traverse rate	-- / 394 ipm



# Spindle specifications

The spindle incorporates double rows of cylindrical bearings to improve the quality and accuracy of machining. Different chucks can be fitted to suit the machining of particular components.

NEX-108M/108Y Spindle nose : A2-6  
NEX-110M/110Y Spindle nose : A2-8

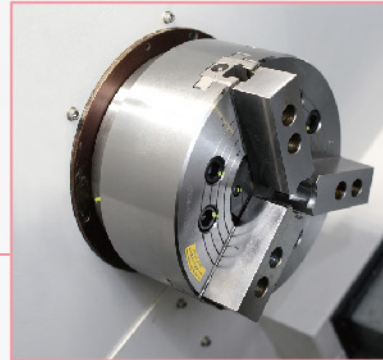
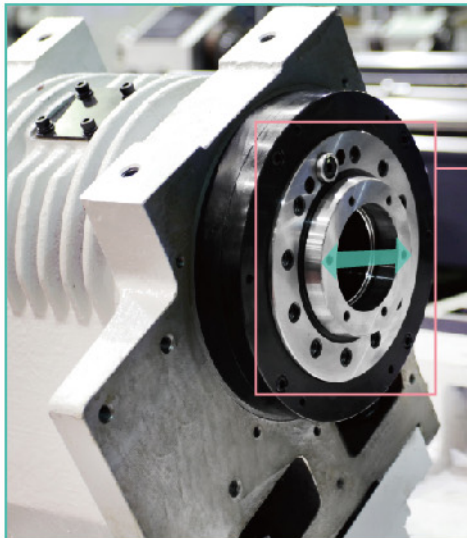

3 Jaw through-hole power chuck(Std.)

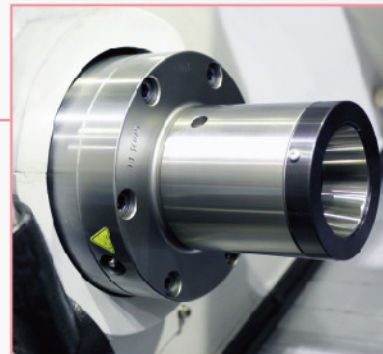

Collet chucks(OP.)

NEX-108M/NEX-108Y  
NEX-110M/NEX-110Y



# Spindle output diagram

Powered by FANUC MOTOR for high stability & high accuracy.

NEX-108M , NEX-108Y

NEX-110M , NEX-110Y

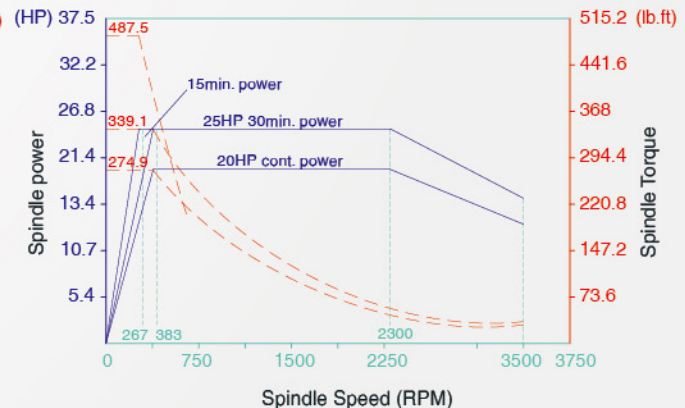
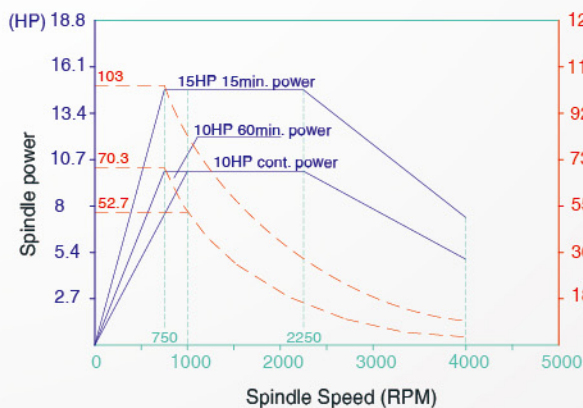





# Turret specifications



The turret is designed for extreme rigidity through its wide and heavy build, inclusion of heavy duty oversized couplings and enhanced clamping pressure.



## Power chart of milling tool

NEX-108M / NEX-108Y / NEX-110M / NEX-110Y

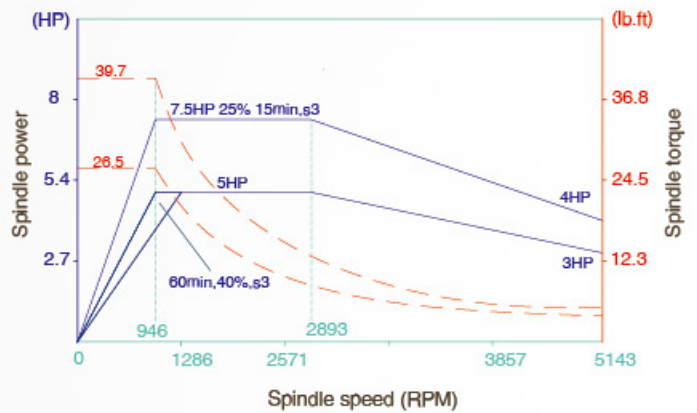

## Machining performance - NEX-108Y ( $\beta$ il 8/8000)

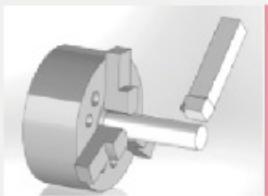

### O.D. heavy cutting

Tool \_\_\_\_\_ 1\*1 Inch  
 Spindle speed \_\_\_\_\_ 1500 rpm  
 Cutting feedrate \_\_\_\_\_ 606.6 ft/min

Cutting depth \_\_\_\_\_ 0.24 Inch  
 Feed per rev. \_\_\_\_\_ 0.014 ipr

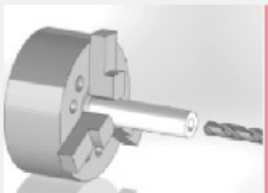

### Drill

Tool \_\_\_\_\_ Drill  
 O.D. drill \_\_\_\_\_ 0.89 Inch  
 Spindle speed \_\_\_\_\_ 220 rpm

Cutting depth \_\_\_\_\_ 0.2 Inch  
 Feed per rev. \_\_\_\_\_ 0.008 ipr

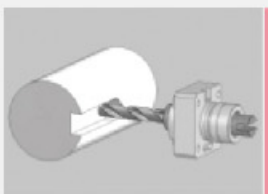

### Heavy milling

Tool \_\_\_\_\_ Milling  
 O.D. milling \_\_\_\_\_ 0.47 Inch  
 Milling speed \_\_\_\_\_ 1300 rpm

Cutting depth \_\_\_\_\_ 0.47 Inch  
 Feed per rev. \_\_\_\_\_ 0.008 ipr





# Machine dimensions

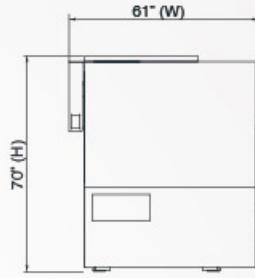
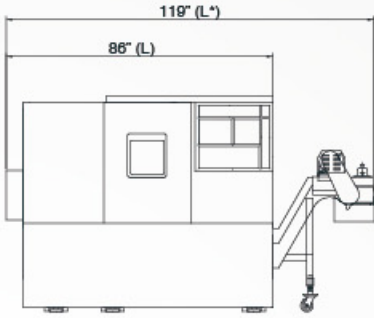

- Length\* — 119 Inch
- Length — 86 Inch
- Height — 70 Inch
- Width — 61 Inch

NEX-108M

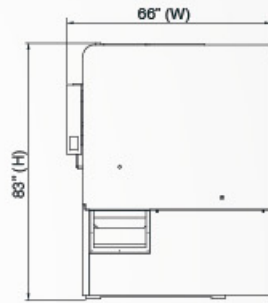
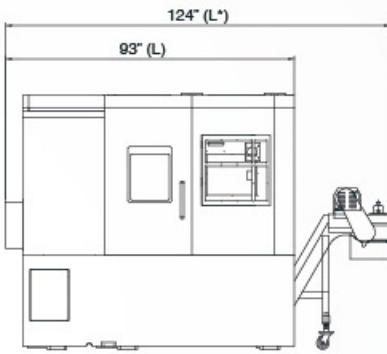

- Length\* — 124 Inch
- Length — 93 Inch
- Height — 83 Inch
- Width — 66 Inch

NEX-108Y

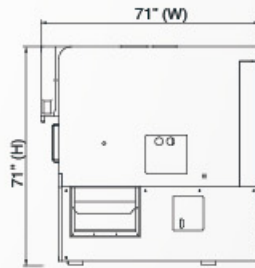
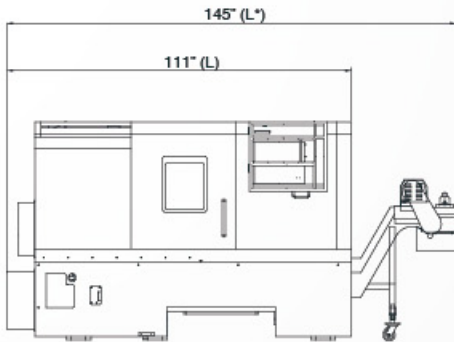

- Length\* — 145 Inch
- Length — 111 Inch
- Height — 71 Inch
- Width — 71 Inch

NEX-110M

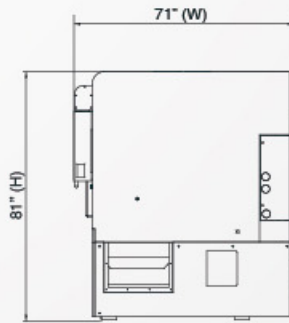
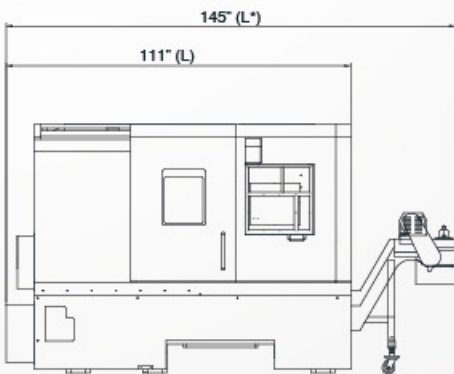

- Length\* — 145 Inch
- Length — 111 Inch
- Height — 81 Inch
- Width — 71 Inch

NEX-110Y

NEX-108M/NEX-108Y  
NEX-110M/NEX-110Y



# Working range | Interference diagram

NEX-108M Working range

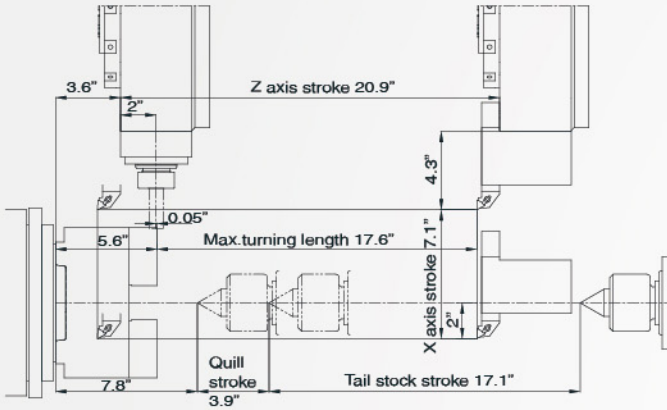

NEX-108M Interference diagram

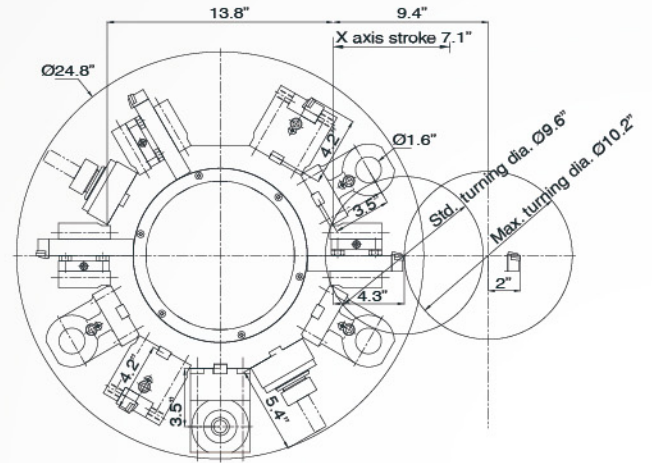

NEX-108Y Working range

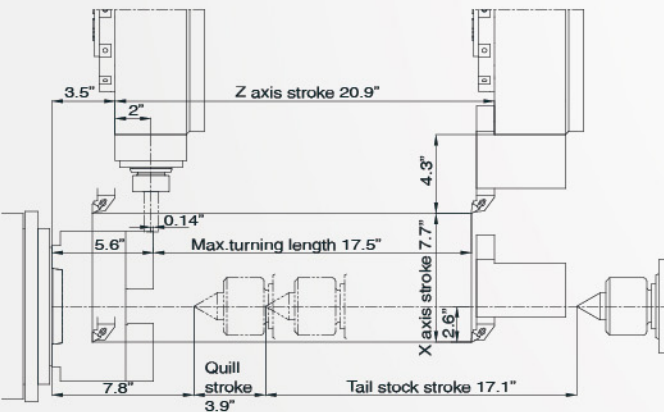

NEX-108Y Interference diagram

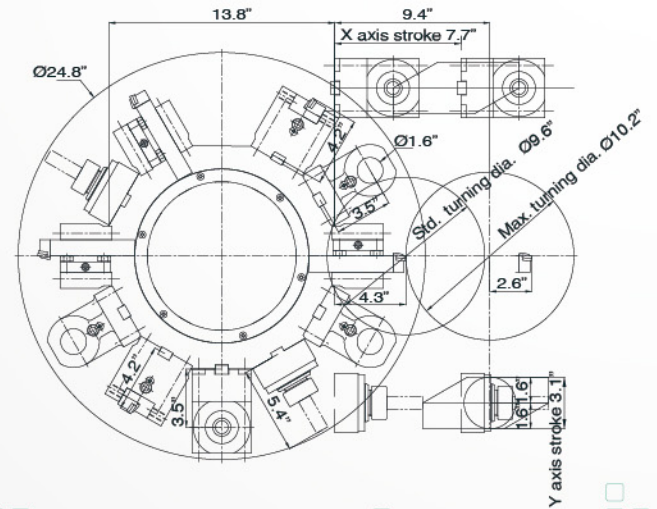

NEX-110M Working range

NEX-110M Interference diagram

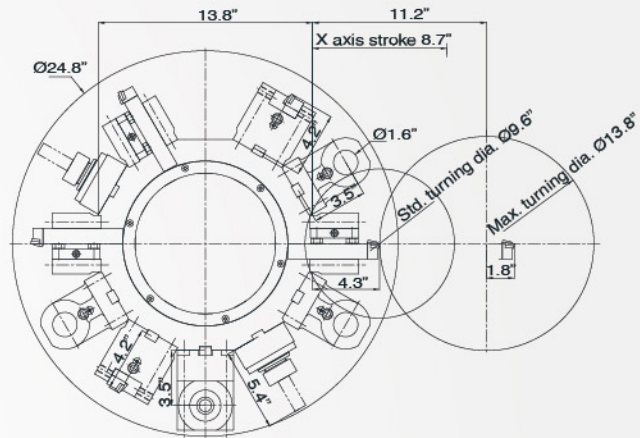
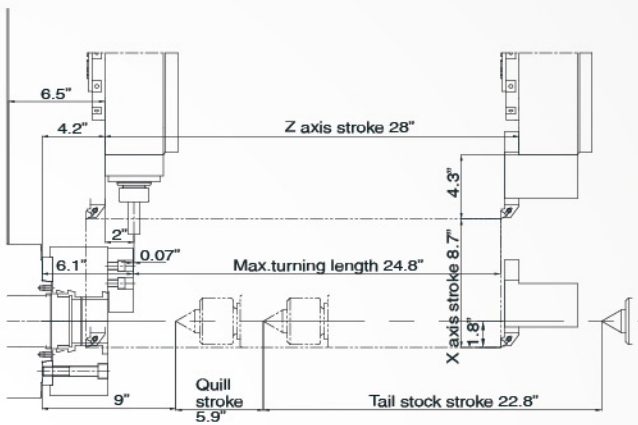

NEX-110Y Working range

NEX-110Y Interference diagram

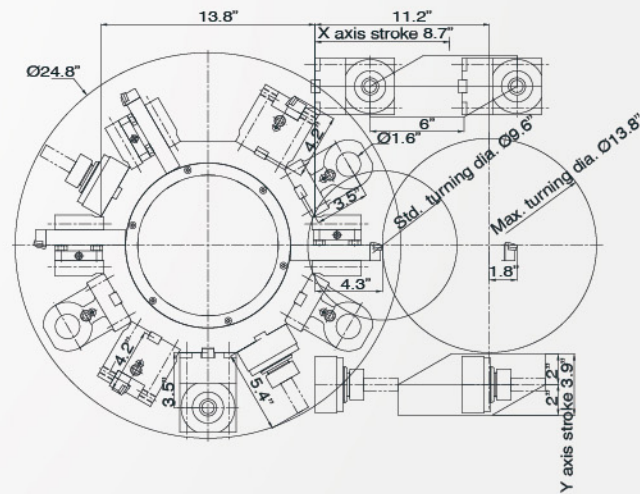
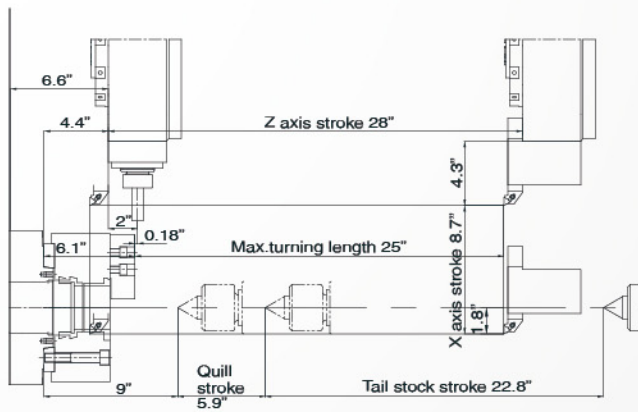





# Tooling system

NEX-108M / NEX-108Y / NEX-110M / NEX-110Y

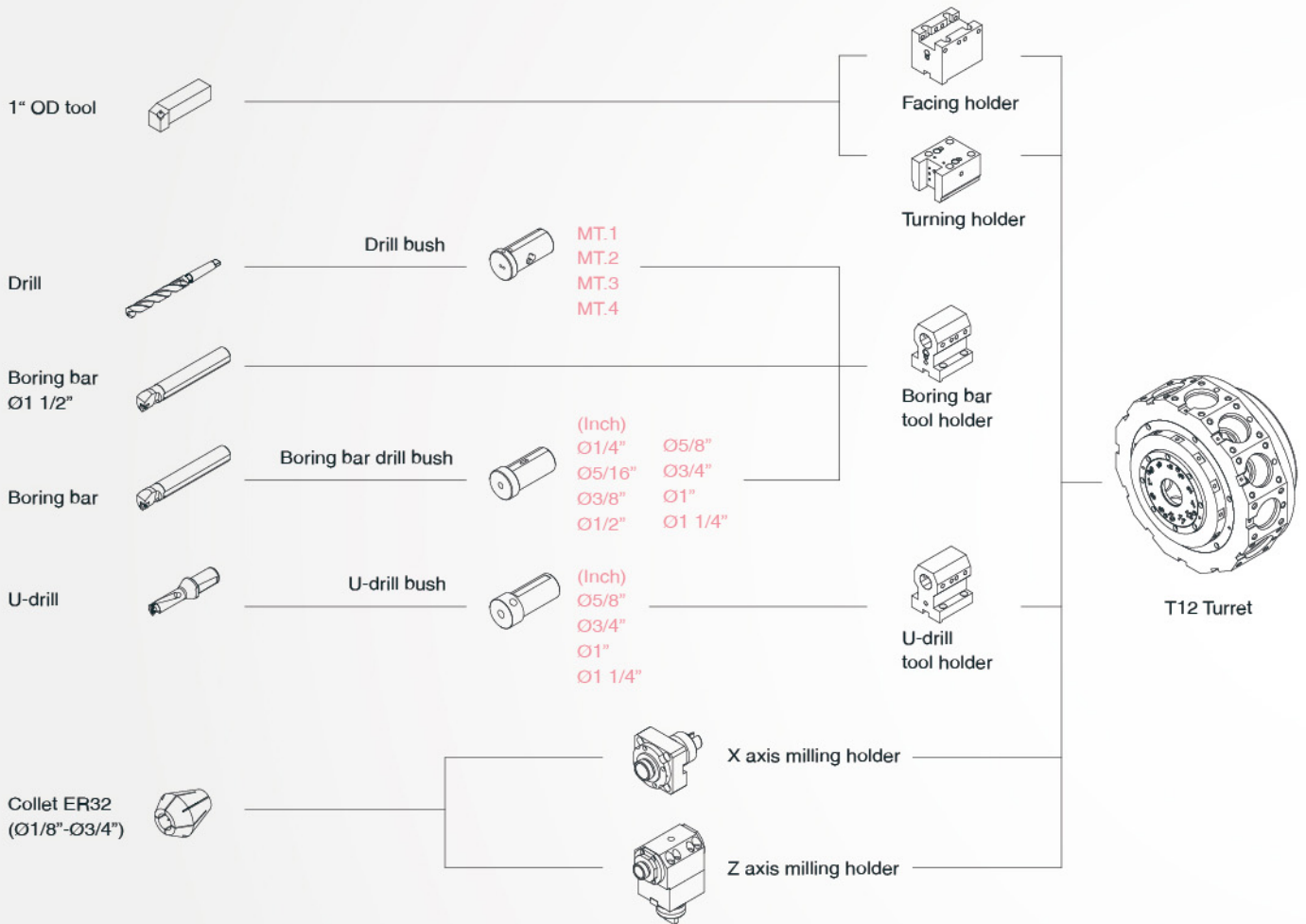



# Specifications

Remark : M = Milling Y = Y axis

Item	Unit	NEX-108M	NEX-108Y	NEX-110M	NEX-110Y
<b>Capacity</b>					
Max. swing	Inch	18.9	18.9	22	22
Std. turning diameter	Inch	9.6	9.6	9.6	9.6
Max. turning diameter	Inch	10.2	10.2	13.8	13.8
Max. turning length	Inch	17.6	17.5	24.8	25
Max. bar work capacity	Inch	2	2	3	3
<b>Travel</b>					
X axis travel	Inch	7.1	7.7	8.7	8.7
Z axis travel	Inch	20.9	20.9	28	28
Y axis travel	Inch	---	±1.6	---	±2
<b>Spindle</b>					
Spindle speed	rpm	4000	4000	3500	3500
Chuck size		8"	8"	10"	10"
Spindle nose		A2-6	A2-6	A2-8	A2-8
Through hole diameter	Inch	2.5	2.5	3.5	3.4
Bearing diameter	Inch	3.9	3.9	4.7	4.7
<b>Turret</b>					
Number of tools		T12	T12	T12	T12
Turning tool shank	Inch	1	1	1	1
Boring bar shank diameter	Inch	1.6	1.6	1.6	1.6
Milling tool shank diameter	Inch	0.8	0.8	0.8	0.8
<b>Tailstock</b>					
Tailstock travel	Inch	17.1	17.1	22.8	22.8
Tailstock spindle diameter	Inch	3	3	4.3	4.3
Taper hole of tailstock spindle		MT.4	MT.5	MT.5	MT.5
Tailstock spindle travel	Inch	3.9	3.9	5.9	5.9
<b>Feedrate</b>					
X axis rapid traverse rate	ipm	787	787	787	787
Z axis rapid traverse rate	ipm	945	945	787	787
Y axis rapid traverse rate	ipm	---	394	---	394
<b>Motor</b>					
Spindle drive motor	HP	15/10	15/10	25/20	25/20
Milling motor	HP	7.5/5	7.5/5	7.5/5	7.5/5
Turret index motor	HP	1.6	1.6	1.6	1.6
X axis drive motor	HP	1.6	3.4	1.6	3.4
Z axis drive motor	HP	3.4	3.4	3.4	3.4
Y axis drive motor	HP	---	3.4	---	3.4
<b>Size</b>					
Length	Inch	86	93	111	111
Height	Inch	70	83	71	81
Width	Inch	61	66	71	71
Weight	lb	9480	9920	13230	14330

※ Specifications are subject to change without notice.

NEX-108M/NEX-108Y  
NEX-110M/NEX-110Y



# Standard and optional accessories

## Standard accessories

- |                                 |                      |
|---------------------------------|----------------------|
| 1. Variable speed spindle       | 9. Leveling pad      |
| 2. Hi-low Gearbox Spindle       | 10. Wedge            |
| 3. Built in spindle motor       | 11. Working lamp     |
| 4. Hydraulic servo turret       | 12. Tool box         |
| 5. Hydraulic tailstock          | 13. Operation manual |
| 6. Manual tailstock base        | 14. Hydraulic chuck  |
| 7. Manual PIN tailstock base    | 15. Foot switch      |
| 8. Automatic PIN tailstock base |                      |

## Optional accessories

- |                              |                           |
|------------------------------|---------------------------|
| 1. Chip conveyor & chip cart | 8. Parts counter          |
| 2. Tool setter               | 9. Collet chuck           |
| 3. Parts catcher             | 10. Manual steady rest    |
| 4. Parts conveyor            | 11. Hydraulic steady rest |
| 5. Barfeeder & Interface     | 12. Rotating tail stock   |
| 6. Air blow                  | 13. Oil mist collector    |
| 7. Automatic Power-off       | 14. Water cooler          |

※ Specifications are subject to change without notice.



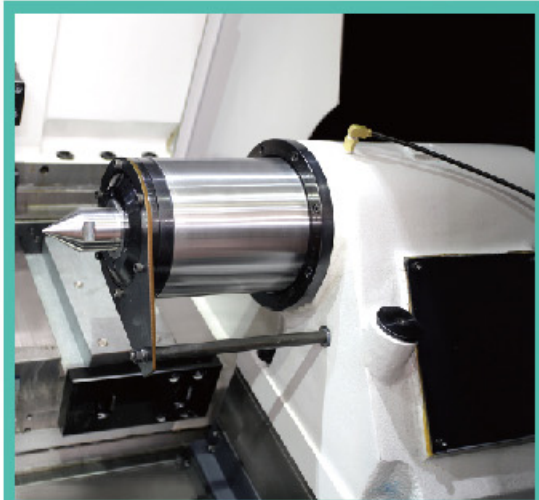

**Rotating tail stock**  
High thrust and clamping forces provide maximum stability especially when working with long workpieces.

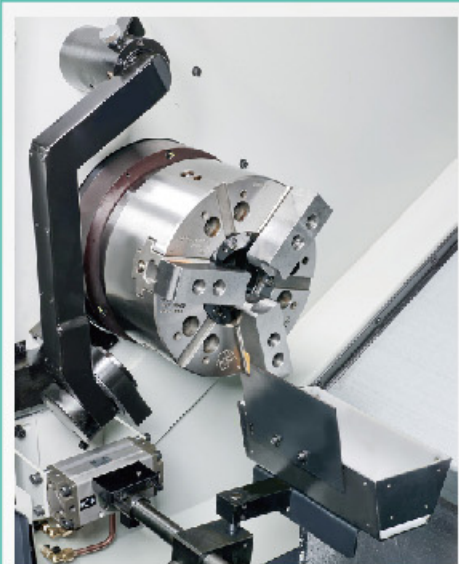

**Parts catcher**



**Manual steady rest**

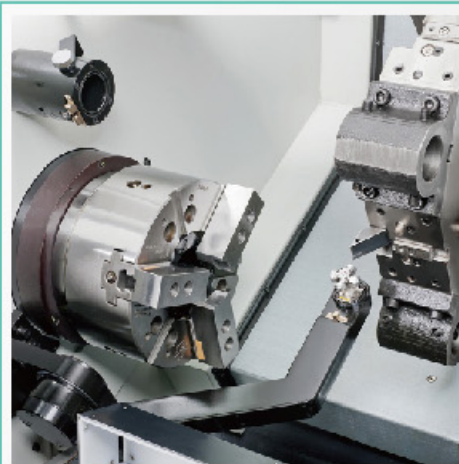

**Tool setter**

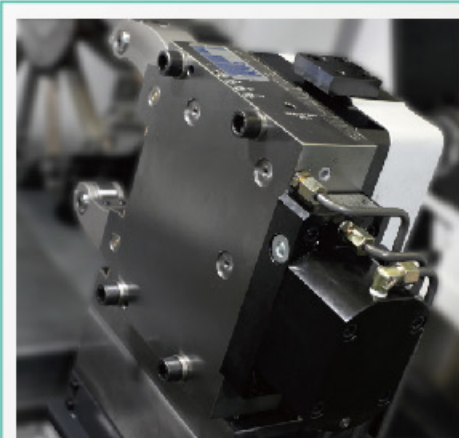

**Hydraulic steady rest**



# NC unit specifications

## Composition

☆ : Standard    ◎ : Optional    ⊕ : Special    --- : N/A    △ : Parameter setting is required

Specifications / Contents	NEX-108M / 108Y / 110M / 110Y
<b>NC Unit</b>	
8.4" Color LCD	☆
10.4" Color LCD	◎
<b>Safety device</b>	
Front door interlock	◎
Front door locking mechanism	◎
Safety relay	◎
Control panel breaker with tripper	◎

## Main function list

☆ : Standard    ◎ : Optional    ⊕ : Special    --- : N/A    △ : Parameter setting is required

Specifications / Contents	NEX-108M / 108Y / 110M / 110Y
<b>Controlled axes</b>	
Least input increment	☆
Maximum programmable dimension(±999999.999)	☆
Least Input increment C	△
Inch/metric selection	☆
Interlock	☆
Machine lock	◎
Emergency stop	☆
Stored stroke check 1	☆
Stored stroke check 2,3	☆
Stroke limit check before movement	△
Chuck tailstock barrier	△
Mirror image (each axis)	△
Chamfering ON/OFF	⊕
Overload detection	◎
Position switch	⊕
<b>Operation</b>	
Auto run (memory)	☆
MDI run	☆
DNC run	⊕
DNC run with memory card	⊕
Program number search	☆
Sequence number search	☆
Sequence number collation and stop	☆
Wrong operation prevention	△
Buffer register	☆
Dry run	☆
Single block	☆
Jog feed	☆
Manual reference point return	☆
Dogless reference point setting	☆
Manual handle feed, 1 unit	☆

Specifications / Contents	NEX-108M / 108Y / 110M / 110Y
<b>Interpolating functions</b>	
Positioning (G00)	☆
Exact stop mode (G61)	☆
Tapping mode (G63)	☆
Cutting mode (G64)	☆
Exact stop (G09)	☆
Linear interpolation (G01)	☆
Circular interpolation (G02/03)	☆
Dwell (G04)	☆
Polar coordinate interpolation	☆
Cylindrical interpolation	☆
Thread cutting	☆
Multiple thread cutting	☆
Thread cutting cycle and retraction	☆
Continuous thread cutting	☆
Variable lead thread cutting	☆
Reference point return (G28)	☆
Reference point return check (G27)	☆
2nd reference point return (G30)	☆
3rd, 4th reference point return	⊕
<b>Feed function</b>	
Rapid traverse override (F0,25%,50%,100%)	☆
Feed per minute	☆
Feed per revolution	☆
Constant tangential speed control	☆
Cutting feedrate clamp	☆
Automatic acceleration/deceleration	☆
Rapid traverse bell-shaped accel/decel	—
Linear accel/decel after feedrate interpolation	☆
Feedrate override (15 steps)	☆
Jog override (15 steps)	☆
Override cancel	☆
Manual feed per revolution	△
<b>Program input</b>	
Tape code (EIA/ISO auto recognition)	☆
Label skip	☆
Parity check	☆
Control in/out	☆
Optional block skip, 1 piece	☆
Optional block skip (2 to 9 pieces)	⊕
Program number O4 digits	☆
Program file name 32 characters	—
Sequence number N5 digits	☆





# NC unit specifications

## Composition

☆ : Standard    ◎ : Optional    ⊕ : Special    --- : N/A    △ : Parameter setting is required

Specifications / Contents	NEX-108M / 108Y / 110M / 110Y
<b>Program input</b>	
Sequence number N8 digits	---
Absolute/incremental command	☆
Decimal point input/Pocket calculator type decimal point input	☆
diameter /radius programming (X-axis)	☆
Auto coordinate /Coordinate system setting(G50)	☆
Drawing dimension direct input	△
G-code system A	☆
G-code system B/C	△
Chamfering/Corner R programming	☆
Programmable data input	☆
Sub program call (10 levels)	☆
Custom macro	☆
Additional custom macro common variables	☆
Single canned cycle	☆
Combined canned cycle I/II	☆
Drilling canned cycle	☆
Arc radius programming	☆
Macro executor	◎
Coordinate system shift/shift direct input	☆
<b>Miscellaneous function/spindle functions</b>	
M function (M3 digits)	☆
Second miscellaneous function (B function)	☆
Spindle functions (S4 digits)	☆
Constant surface speed control	☆
Spindle orientation	☆
Rigid tap (spindle center) /(rotary tool)	☆
<b>Tool functions/tool offset functions</b>	
T function (T2+2 digits)	☆
Tool offsets, 64 pieces	☆
Tool offsets, 99 pieces	◎
Tool offsets, 200/400 pieces	---
Tool geometry size data, 100 pieces	---
Tool position offset	☆
Tool diameter /nose R compensation	☆
Tool geometry /wear compensation	☆
Tool offset counter input	☆
Tool offset measured value direct input	☆
Tool offset measured value direct input B	◎
Tool life management	△
<b>Accuracy offset functions</b>	
Backlash compensation/by rapid traverse/feedrate	☆
<b>Editing</b>	

Specifications / Contents	NEX-108M / 108Y / 110M / 110Y
Part program memory capacity 128Kbyte (320m)	---
Part program memory capacity 320Kbyte (800m)	☆
Part program memory capacity 512Kbyte (1280m)	◎
Part program memory capacity 1Mbyte/2Mbyte	---
Registrable programs, 63 programs	---
Registrable programs, 400 programs	☆
Registrable programs, 1000 programs	---
Program editing/protection	☆
Extended program editing	☆
Background editing	☆
<b>Setting/display</b>	
Status display	☆
Clock function	☆
Current position display	☆
Program comment display (31 characters)	☆
Parameter setting and display	☆
Alarm display/Alarm log display	☆
Operator/ operation message log display	☆
Run hours and parts count display	☆
Actual speed display	☆
Actual spindle speed and T code display	☆
Floppy cassette directory display	☆
Grouped directory display and punching	☆
Servo adjustment screen	☆
Maintenance information screen	☆
Data protection key, 1 kind	☆
Help function	☆
Self diagnostic function	☆
Scheduled maintenance screen	☆
Hardware & software system configuration display	☆
Graphic display	☆
Dynamic graphic display	◎
<b>Display languages</b>	
English	☆
Japanese (Kanji)	△
Other language	△
Display language dynamic switching	☆
<b>Data I/O</b>	
RS-232C interface for 1 ch	☆
Fast data server	⊕
External message	☆
External workpiece number search	⊕
Memory card I/O	☆

More



[www.takisawa.com.tw](http://www.takisawa.com.tw)

**Taiwan TAKISAWA Technology Co., Ltd.**

No.505, Sec. 3, Yanping Rd., Pingzhen Dist.,  
Taoyuan City 324, Taiwan.

TEL : +886-3-4643166 FAX : +886-3-4642614

No.89, Sec. 1, Meishi Rd., Yangmei Dist.,  
Taoyuan City 326, Taiwan.

TEL : +886-3-4813119 FAX : +886-3-4813185

E-mail : [callcenter@takisawa.com.tw](mailto:callcenter@takisawa.com.tw)

**Takisawa Tech Corp.**

1500 S. Milliken Avenue, #B, Ontario, CA 91761.USA

TEL : (909)218-4466 FAX : (909)218-4981

**TAKISAWA<sup>®</sup>**  
**TAIWAN**

Distributor