

1973 H1-D PARTS DIAGRAM

OIL PUMP ('73-'75 D/E/F & '76 A8)

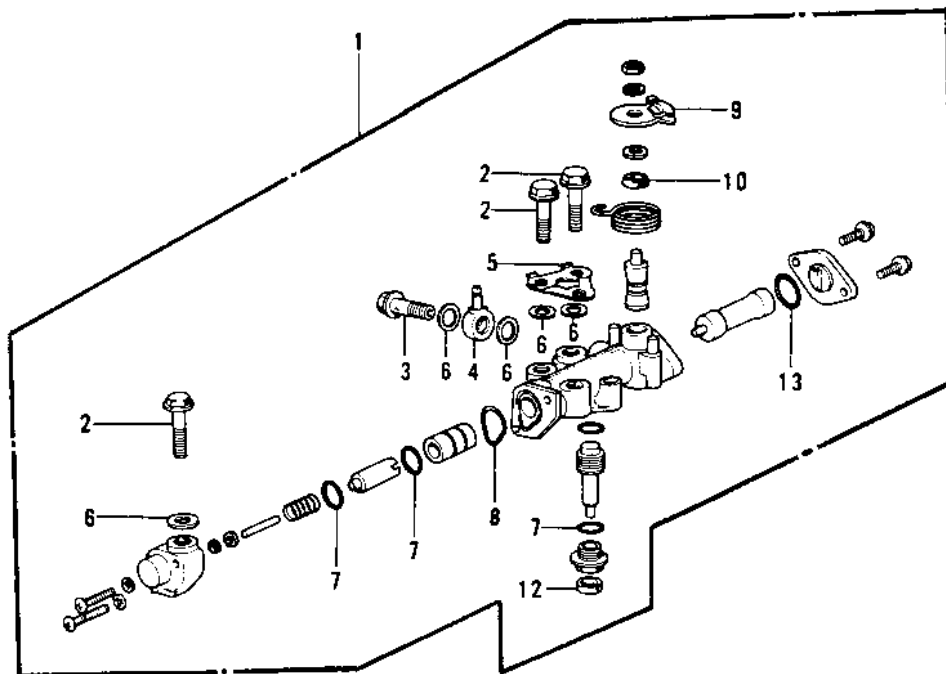
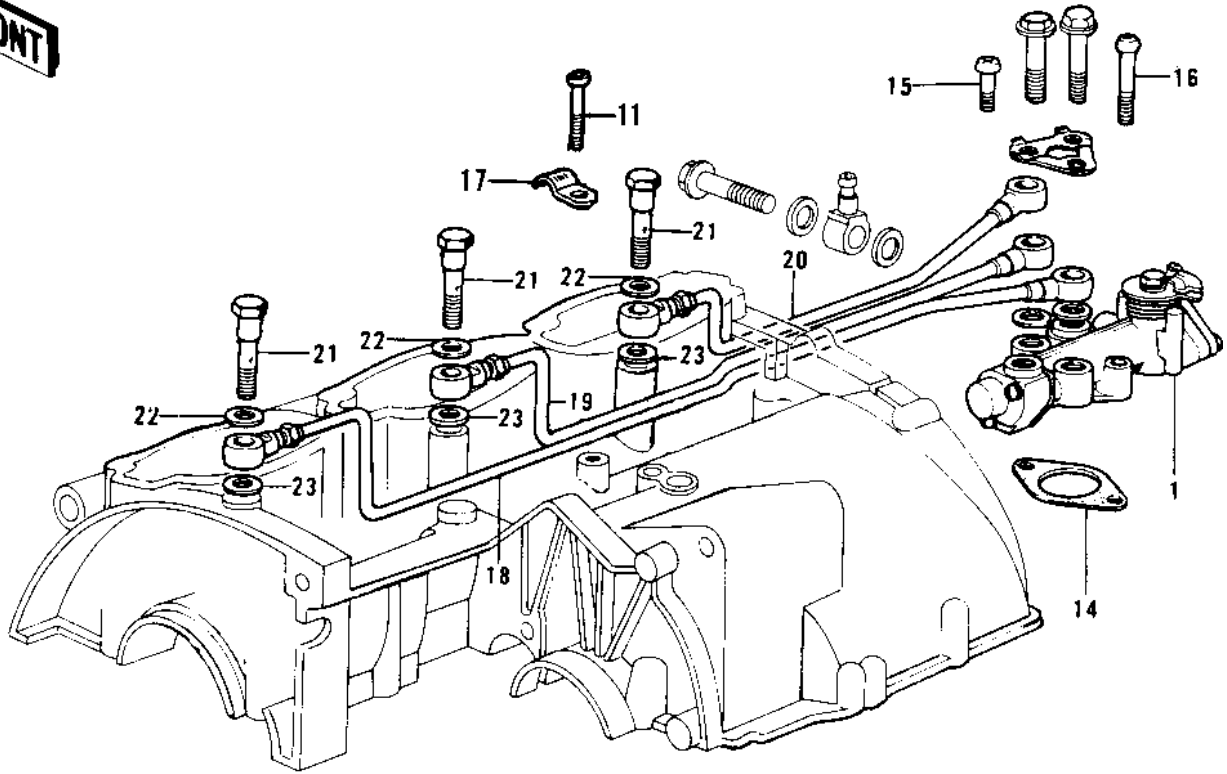

1973 H1-D PARTS LIST

OIL PUMP ('73-'75 D/E/F & '76 A8)

ITEM NAME	PART NUMBER	QUANTITY
OIL PUMP ASSY (Ref # 1)	16082-040	1
BOLT BANJO (Ref # 2)	92060-008	1
BOLT BANJO (Ref # 3)	92060-009	1
CONNECTOR BANJO (Ref # 4)	92061-015	1
WASHER,OIL PUMP LOCK (Ref # 5)	92024-058	1
WASHER OIL PUMP BANJO (Ref # 6)	92022-077	1
"O" RING,OIL PUMP SHT (Ref # 7)	16090-002	1
"O" RING,UPPER CAP (Ref # 8)	16088-002	1
LEVER-OIL PUMP CABLE (Ref # 9)	16096-003	1
SEAL-OIL,CAMSHAFT,"X" (Ref # 10)	92049-1294	1
SCREW PAN HEAD 6X10 (Ref # 11)	220B0610	1
OIL SEAL OIL PUMP SHT (Ref # 12)	16091-001	1
"O" RING,LOWER CAP (Ref # 13)	16090-003	1
GASKET,OIL PUMP (Ref # 14)	11060-1160	1
SCREW-PAN-CROS (Ref # 15)	220B0514	1
SCREW PAN CROSS,5X28 (Ref # 16)	220B0528	1
HOLDER OIL PIPE (Ref # 17)	16068-004	1
PIPE OIL (Ref # 18)	16134-007	1
PIPE OIL (Ref # 19)	16134-008	1
PIPE OIL (Ref # 20)	16134-009	1
BOLT-BANJO,CR (Ref # 21)	92060-010-79	1
GASKET CHECK VALVE (Ref # 22)	92065-058	1
GASKET CHECK VALVE (Ref # 23)	92065-023	1