

Technical Services • Customized Products • Comprehensive Solutions



# Amine Optimization

Specializing in Amine Unit Performance

CONSULTING & TROUBLESHOOTING • PROCESS SIMULATIONS • FOAMING & CORROSION CONTROL  
CHEMICAL ADDITIVES • COALESCENCE & FILTRATION • ACTIVATED CARBON

[www.AmineOptimization.com](http://www.AmineOptimization.com)



## Improving Performance of Amine Units is Our Mission

Foaming, corrosion, fouling, low performance, unable to meet specifications, high filtration costs, amine losses: these are just some of the problems that plague amine systems. Amine Optimization is the only company in the world that focuses exclusively on technologies and services for amine units with respect to total unit performance. We offer the most comprehensive line of products and technical services for amine units. All products and services are matched to individual amine units.

Optimizing the performance of amine units can involve fine tuning multiple variables. This includes a detailed analysis of the individual parameters and components, in addition to their relation to each other as the overall process. Our Holistic approach to amine systems use process simulators, laboratory analysis, field testing data, and the correctly matched products to operate systems at design capacity, and beyond with high reliability, consistent stability (low foam formation), and lower operational costs.

## Amine Unit Diagram & Process Deficiencies

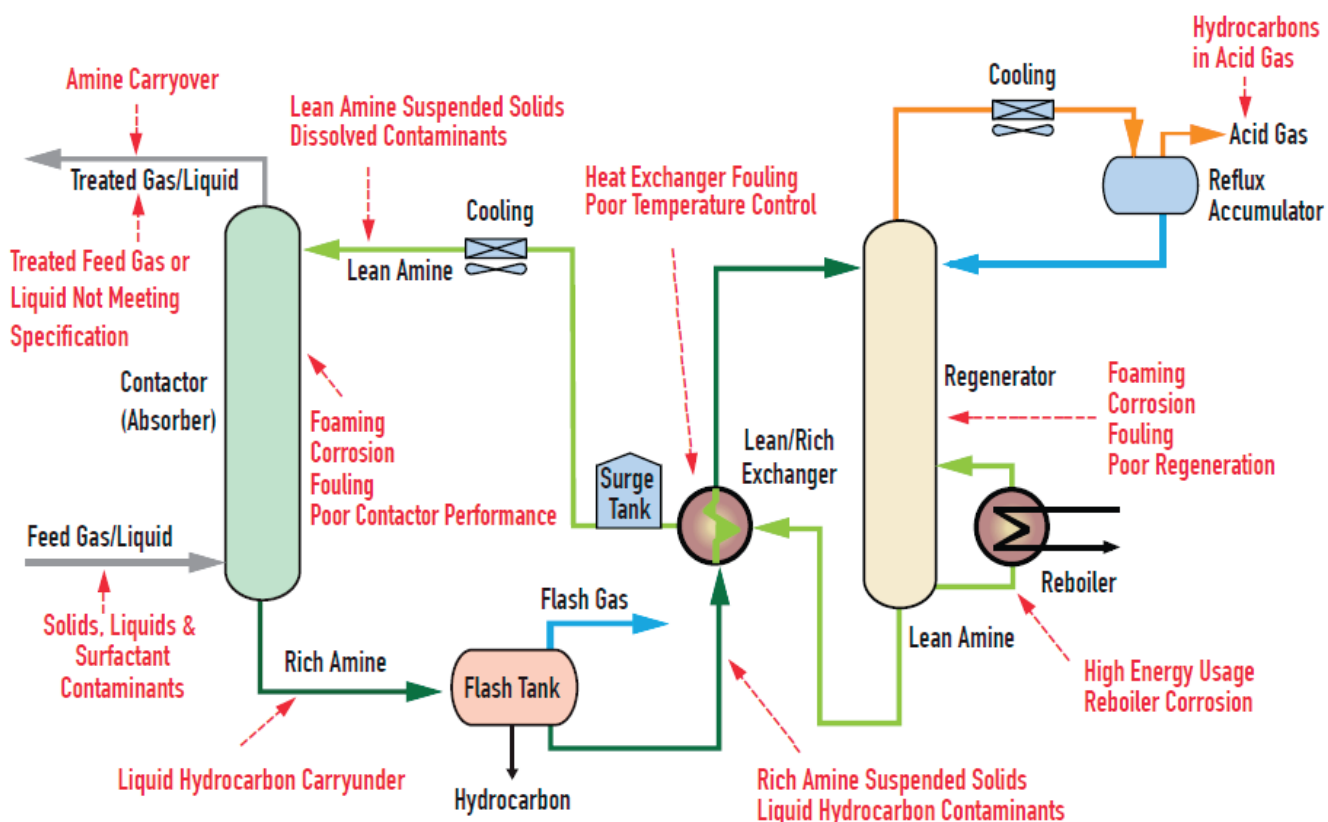



# Amine Optimization

Specializing in Amine Unit Performance



## Inlet Separation Gas Coalescing and Liquid Coalescing

Improper or deficient inlet filtration and liquids separation upstream of the amine unit can often lead to foaming, fouling, or corrosion among other detrimental effects. To address the separation of solids and liquids in both liquid and gas feed streams entering the amine unit, the technology of choice is not only important but how it's applied is just as critical. For over 50 years plants have been installing separators and newer coalescers but they still fail to meet expected performance. Amine Optimization Company can determine why your system is lacking in performance and provide improvement solutions.

### LIQUID CONTAMINANTS FOUND IN GAS AND LIQUID STREAMS

Compressor Lube Oils • Hydrocarbon Condensates • Amines • Glycols • Corrosion Inhibitors • Brine  
Completion Fluids • Produced Water • Solvents • Organic Acids • H<sub>2</sub>S Scavengers

### SOLID CONTAMINANTS FOUND IN GAS AND LIQUID STREAMS

Iron Sulfides • Iron Oxides • Corrosion Products • Scale • Black Powder • Asphaltenes • Waxes  
Desiccant Fines • Sand • Salts • Solid Hydrocarbon Agglomerations (gels) • Clay • Silt

## Coalescing, Filtration, Adsorption & Complete Systems

Proper coalescing and filtration involves many variables and it's challenging to create a system that is cost effective, requires minimal operator intervention, and efficient. Amine Optimization has the knowledge and experience in designing, building and testing capabilities to implement coalescing and filtration systems delivering the necessary performance for amine unit protection. We offer:

- Gas coalescer vessels and complete systems for inlet separation
- Filter vessels and complete systems for amine solvent filtration (rich/lean)
- Filter and coalescer elements (internal replacement elements)
- Vessel reconfigurations for improving existing vessel performance
- Rich amine hydrocarbon coalescers and amine solvent recovery systems
- Activated carbon vessels and complete systems

### SPECIALIZED MEDIA TECHNOLOGY

There are many types of filtration and coalescing media materials available. The skill is in knowing how to choose the right media and efficiency that is cost effective and compatible with the amine solvent. Improper material selection leads to chemical incompatibility contaminating the amine solvent and incorrect separation efficiency of contaminants.

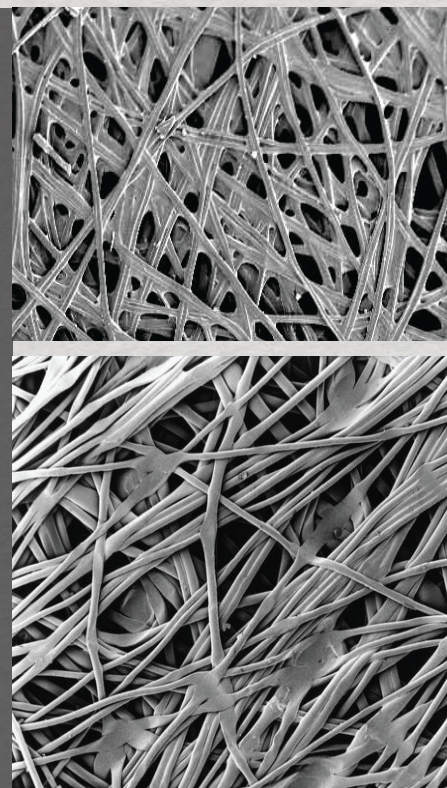

## Complete Systems

Amine Optimization designs and fabricates the most efficient and advanced coalescing, filtration and activated carbon vessels and systems. We also engineer complete skidded systems for plug and play installation in addition to installation and operation support.

### TECHNOLOGY LICENSING

Amine Optimization has a program to license its vessel designs and systems for local fabrication. The program includes vessel or systems designs, fabrication guidelines, internal components, and operational manuals.

### RENTAL FILTER VESSELS

Amine Optimization Company has a number of filter vessels for rent. These can be deployed at a moment's notice, and can utilize different types of filter media. The vessel rental program includes technical services and spare parts.



LIQUID COALESCERS • GAS COALESCERS • GAS AND LIQUID FILTERS • ACTIVATED CARBON BEDS

## Vessel Reconfigurations

Amine Optimization Company has the capabilities and expertise for reconfiguring your existing coalescer and filter vessels to utilize the most efficient and cost effective coalescing or filtration media materials for each specific amine unit individually.

Vessel reconfigurations also address additional issues such as design deficiencies, chemical compatibility aspects, maintenance shortcomings, and improved on-line lifetime.



## Amine Solvent Carryover Losses

Amine unit solvent losses are a prevalent problem in several plants that treat liquid streams such as LPG (liquefied petroleum gas) or NGLs (natural gas liquids) among others. In liquid streams, amine solvent losses are typically caused by solubility of the amine solvent in the treated liquid hydrocarbon stream. Losses can also be caused by emulsification of the amine solvent with the liquid hydrocarbon resulting often cases in large carryover downstream. In gas treating, amine solvent losses can be caused by foaming episodes, system upsets, mechanical entrainment or high gas velocities into the absorber or contactor.

The cost associated with amine solvent losses can be significant and can reach millions of dollars per year. In addition there can be several negative downstream effects. The impacts of amine losses can be:

- Amine solvent costs (up to 10 USD per pound for formulated amines)
- Amine inventory, storage and replenishment maintenance
- Downstream impacts in fuel gas lines, burners, compressors and turbines
- Downstream impacts in mercaptans removal, alkylation and caustic units
- Downstream effects in caustic treating units or mercaptans removal units
- Failed copper strip corrosion tests or failed sulfur content specifications



# Amine Optimization

Specializing in Amine Unit Performance

## Amine Solvent Losses Minimization and Amine Solvent Recovery

Amine solvent losses minimization program at Amine Optimization is a multi-component approach that includes on-site testing, engineering evaluations and simulations. The program starts with no capital cost. The program includes:

- Amine absorber simulations and design evaluation
- Process set points adjustments for amine loss minimization
- Instrumentation verification
- Suspended solids evaluation at lean amine stream
- Contaminant profiles at inlet gas and liquid streams
- Amine loss quantification in gas and liquid streams
- Surfactant and hydrocarbon analysis
- Separation system evaluation (filters, coalescers and activated carbon beds)

## Amine Solvent Recovery Technology

For cases when amine solvent losses can't be solved or controlled using simple process changes it is necessary to install an Amine Solvent Recovery Technology. The system can recover 95%+ of the amine solvent lost in a way that the recovered amine solvent can be added back to the amine unit. This process eliminates the detrimental downstream effects caused by amine solvent carryover. Each amine recovery system is fully automated, instrumented, and fabricated as a complete skidded system.



## Amine Solvent Foaming Control Assurance

Amine solvent foaming is perhaps the highest cost upset an amine unit can experience. Most foaming incidents can be attributed to inlet contaminants such as suspended solids, surfactants, lubrication oils, or certain dissolved contaminants (gas phase or liquid phase). Despite having inlet separators, filters and coalescers, units can still foam. Understanding why and the root cause is key to minimizing foaming. Ask for an evaluation if you are experience foaming.

### FOAM CONTROL PROGRAM

By using Amine Optimization Company's technical services and products, the severity and frequency of foaming events can be significantly decreased. The technical services and products are tailored to the specific amine unit for maximum performance.





## Antifoams and Chemical Additives

All chemical additive products developed by Amine Optimization are designed and matched to individual amine units with the objective of targeting specific problems such as corrosion, foaming, emulsification or fouling. The Amine Optimization chemical additive products are designed to be compatible with the whole amine system. Amine Optimization Company has the best and most effective antifoam products in the industry.

### TYPES OF CHEMICAL ADDITIVES:

- Antifoams for gas treating, polyolglycol or silicone-based
- Emulsion breakers for liquid treating, polyol or phenol resins-based
- Corrosion inhibitors for amine units, with no foam or emulsion formation
- Activated carbon, multiple types for liquid and gas processing
- Adsorbents for surfactants removal from liquid streams
- O<sub>2</sub> scavengers for feed stream contamination and amine solvents
- Cleaning agents, formulations and surfactants for amine unit cleaning
- Antifoulants and dispersants for minimizing solids deposition on surfaces
- Chelants and complexing agents for solubilizing solid iron sulfides

## Amine Solvent Foam Test Kit

The amine foam test kit designed and manufactured by Amine Optimization Company allows the user to test foaming conditions immediately, consistently, and begin building a history of comparable data of foaming events. The foam test kit is also designed to help optimize the antifoam selection and effectiveness. Every kit comes packed in a heavy duty case for easy transportation. Assembly time takes less than five minutes. The foam test kit can also be used to determine the effectiveness of a carbon bed on foam promoting contaminants and foam tendency of new amine entering the plant.

### EACH FOAM TEST KIT INCLUDES:

- Operation manual, instructional videos for assembly, operation and cleaning
- Foam test columns, air pump, flowmeter, connections, tubing and clamps
- Heavy duty case with foam inserts for safe transportation
- Antifoam library (7 different non-silicone antifoam types)
- Consumables and spare parts

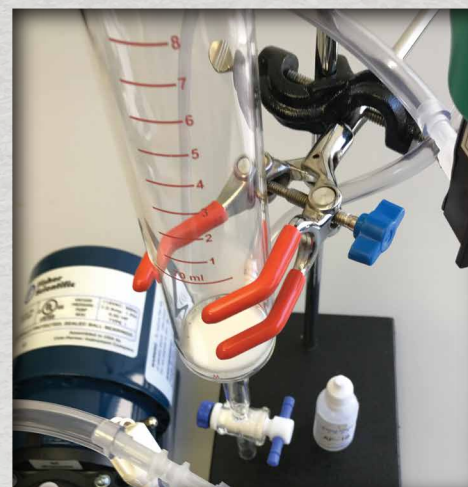



# Amine Optimization

Specializing in Amine Unit Performance

## Activated Carbon Beds

Activated carbon beds are often a neglected and misunderstood piece of equipment in an amine unit. An optimized activated carbon bed is a key component to good amine unit operation as it removes a variety of soluble contaminants in the amine solvent.

A carbon bed provides adsorption of soluble contaminants in a process stream. It is not intended to be used as a filter. Carbon beds should not build differential pressure over time. They should always be protected with a suitable pre-filter and should always be used in combination with a suitable post-filter.

### APPLICATIONS

Lean amine purification • Rich amine purification • Vent gas odor control • Amine purification at storage tank  
Inlet feed gas • General organic contamination removal • Residual H<sub>2</sub>S and mercaptans removal • Surfactants removal

### A WELL-DESIGNED ACTIVATED CARBON BED HAS MANY FUNCTIONS IN AN AMINE UNIT

Protects absorber from foaming • Reduces need for antifoam additives  
Reduces amine make-up • Reduces corrosion • Improves absorber efficiency



ACTIVATED CARBON PRE-FILER VESSEL • ACTIVATED CARBON BED • ACTIVATED CARBON POST-FILTER VESSEL

## Activated Carbon Characteristics

Activated carbon is a powerful molecular separation material. It is capable of removing several dissolved contaminants in amine solvents and is a critical component of the amine units.

### ACTIVATED CARBON CAN REMOVE:

- Soluble contaminants that cause amine solvent foaming
- Soluble amine degradation products
- Soluble hydrocarbons in the amine solvent
- Gas phase contaminants in the inlet feed gas stream

**CONFIGURATIONS:** Canisters or Bulk Supersacks

**TYPES:** Powder, Granular, Pelletized, and Extruded

**SOURCES:** Lignite, Peat, Wood, Bituminous and mixed types

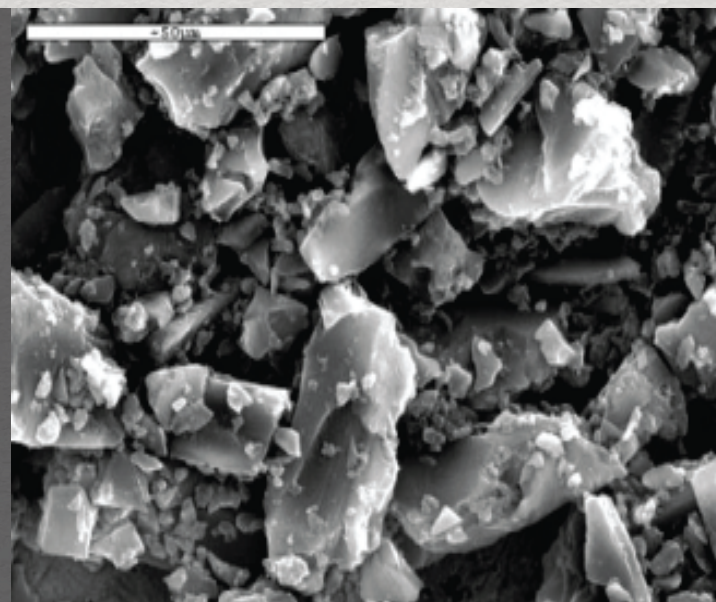

# Technical Services, Consulting, Testing, and Troubleshooting

Expertise, experience and knowing how to combine the right technologies is key to amine unit performance. Amine Optimization Company has the knowledge, testing capabilities, products and services to match to individual amine units and optimize their operations. We have process simulators, onsite testing and troubleshooting services.



## Amine Unit Technical Training Seminars

Amine Optimization Company offers a series of on-site technical seminars and training on a variety of topics related to amine units. Every course is tailored toward specific company needs utilizing case studies taken from current and previous projects. Areas covered in the technical seminars are: general amine process unit operation, equipment details, filtration and coalescing, inlet separation, activated carbon, foaming, fouling, corrosion, failure modes and troubleshooting.

## Amine Unit Process Stimulation

Amine Optimization Company provides amine simulations that are unique for every plant. Each simulation is stripped down piece by piece to determine where each plant may be optimized. By examining each amine unit and its unique parameters amine optimization can help ensure the amine unit is meeting its full potential at the lowest cost output.

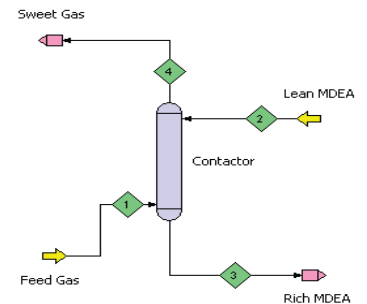

## Amine Unit Audits

Amine Optimization Company provides short- and long-term amine audits. These audits are used to determine the current status of the amine unit and help provide suggestions to reach full potential. Routine audits allow a company to track their potential issues and eliminate them before they become a problem and higher cost. Audits cover filters, coalescers, anti-foam usage, carbon adsorption, process parameters, etc.

## Analytical Services

Amine Optimization Company uses chromatography, microscopy, spectroscopy, and a variety of chemical and materials analysis in addition to advanced techniques to determine the root-causes of the problems in amine units. Scheduled testing on a regular basis can be performed at specific locations to stay ahead of big process upsets, avoid unscheduled shutdowns and minimize any production losses.

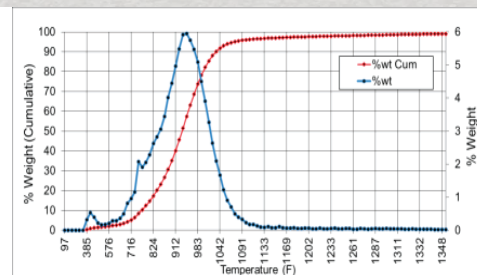

[www.AmineOptimization.com](http://www.AmineOptimization.com)



Amine Optimization Company  
25003 Pitkin Road, Suite A100  
The Woodlands, Texas 77386 USA



+1 (832) 777-7006



[help@amineoptimization.com](mailto:help@amineoptimization.com)