



**Bài 1:**

Luyện nét, hiểu khối căn bản, dùng khối căn bản



**Bài 2:**

- Hình trụ, biến thể hình trụ, cắt hình trụ.

Phối cảnh 1 2 tụ

Potions sketch

Homework:

- vẽ khối hình trụ như ảnh xong vẽ đường cắt hình trụ

- vẽ các góc khó hơn nếu đc

- vẽ lại một con thú bài 1

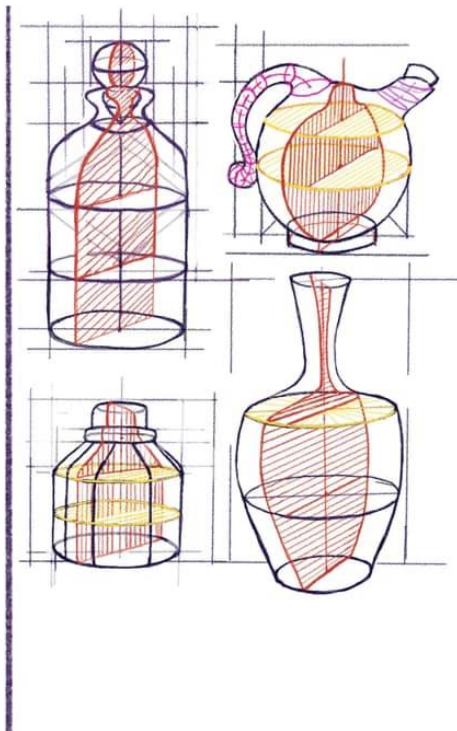
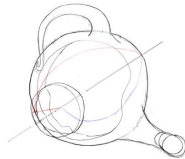
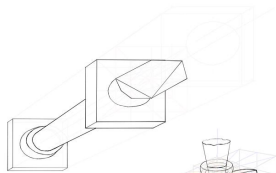
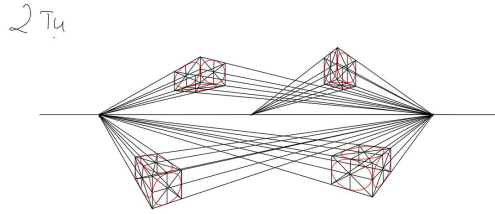
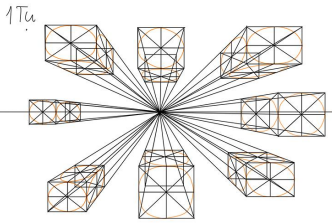

**Bài 3:**

Phối cảnh. Nâng cao

Homework:

Hoàn thiện khối hộp trên lớp.

Vẽ thêm khối hộp có nắp cong.

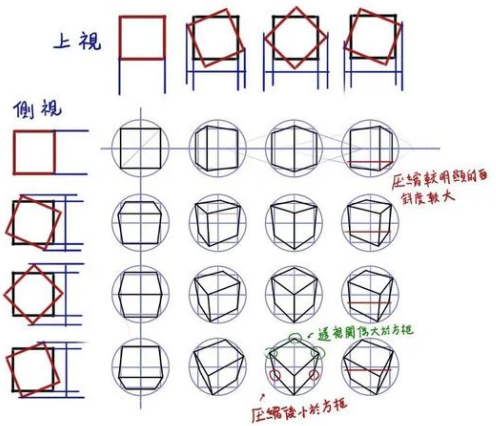
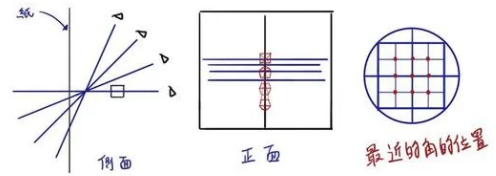
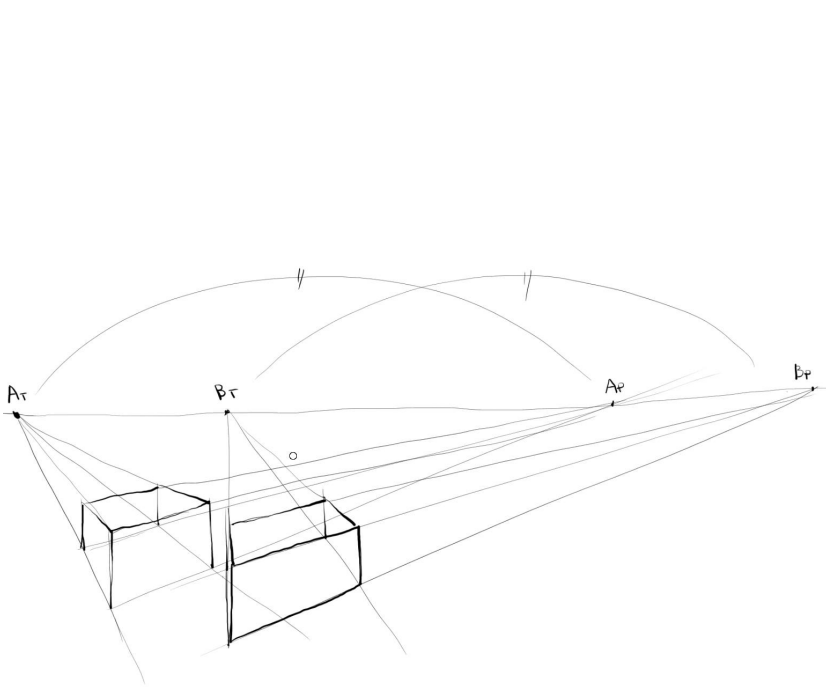

然而怎么转都不会比圆大

06/06/2019 11:30

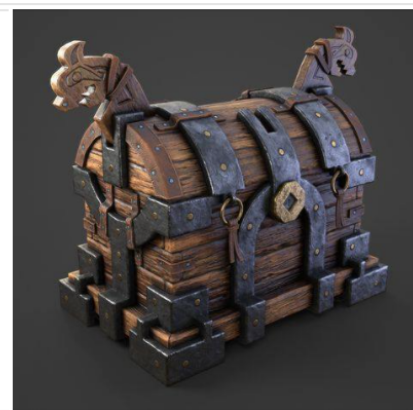
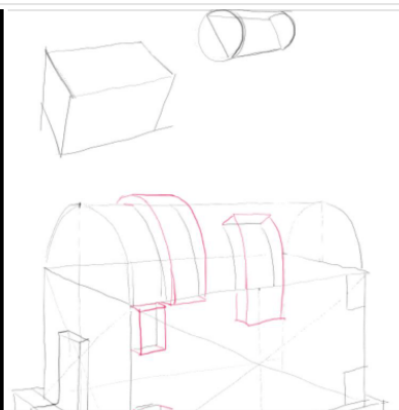
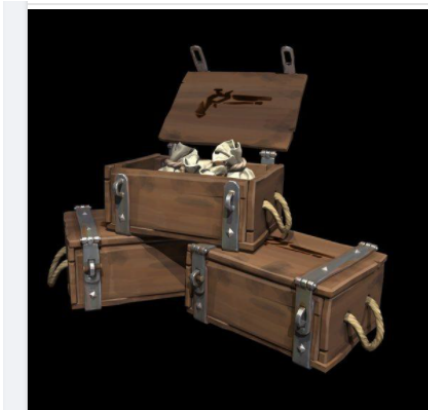
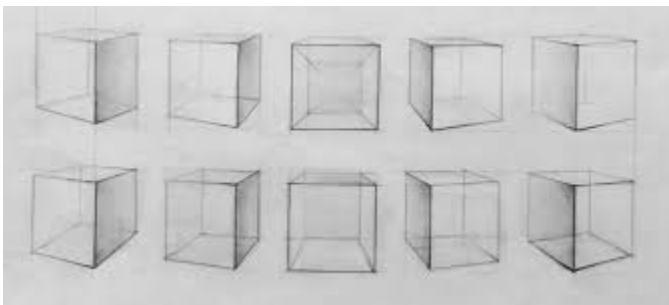

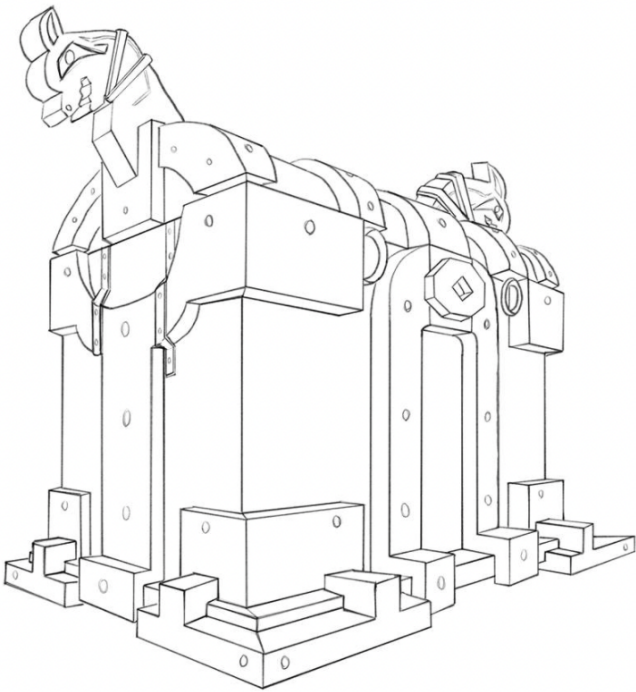
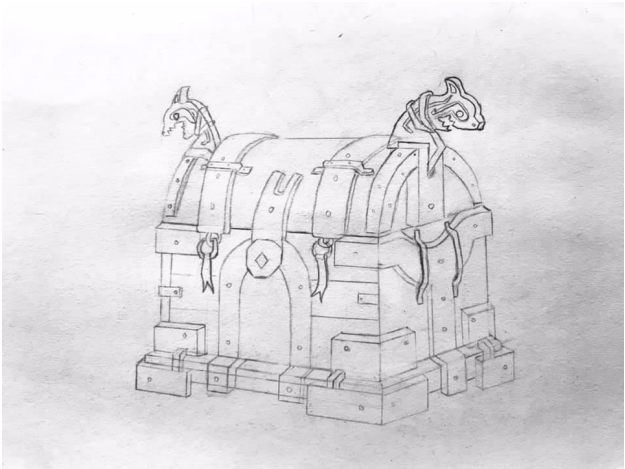
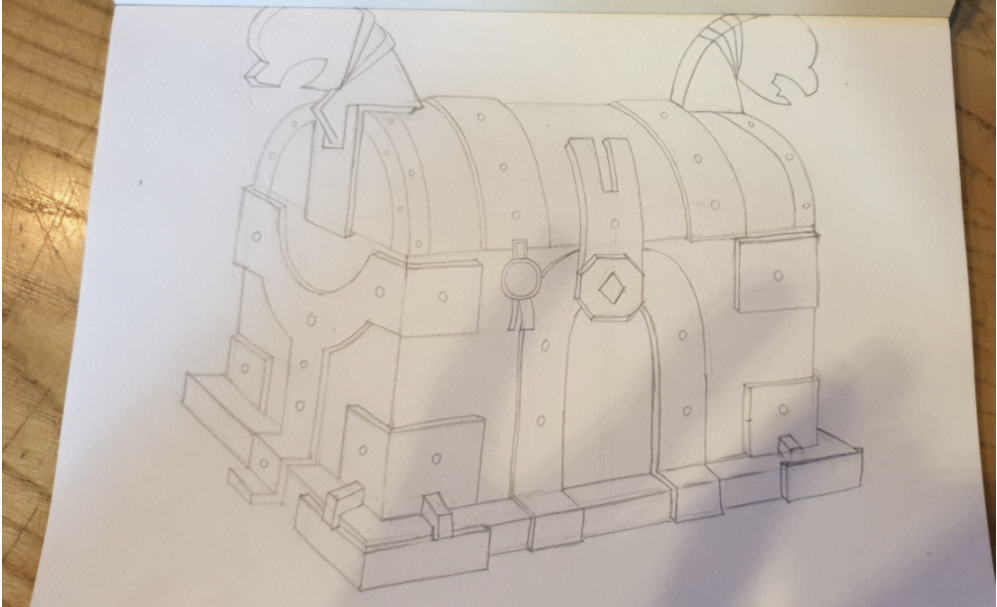

**Bài 4:**

Phối cảnh 3 tụ.

Loomis head

**Bài tập về nhà:**

- Hoàn thiện toàn bộ bài trong tuần. Vẽ thêm 2-5 đầu loomis. Nét vẽ có thể tối giản như hình mẫu ref

Gvien chọn

- (Vẽ một đầu lâu SKull nếu có thể)

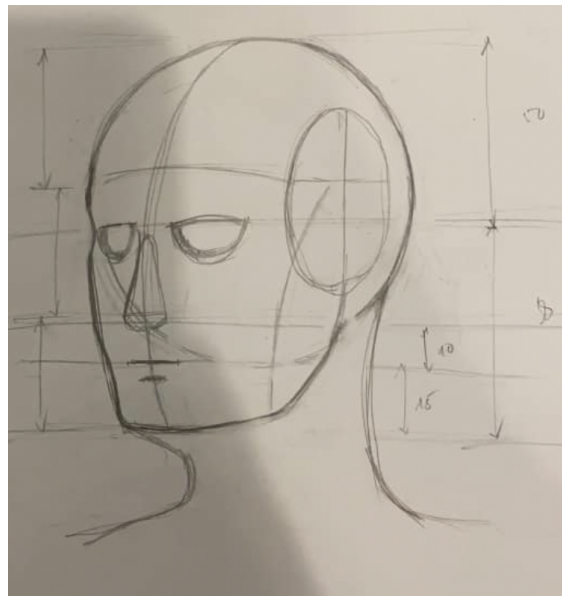
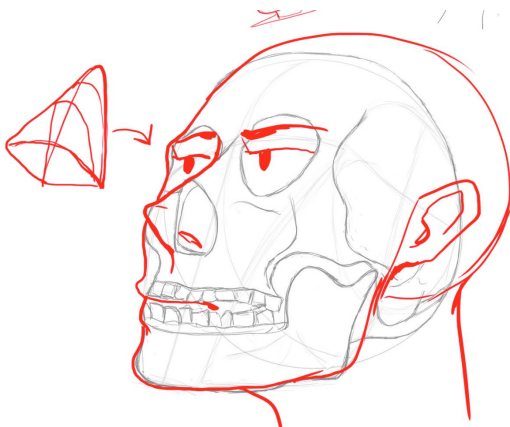
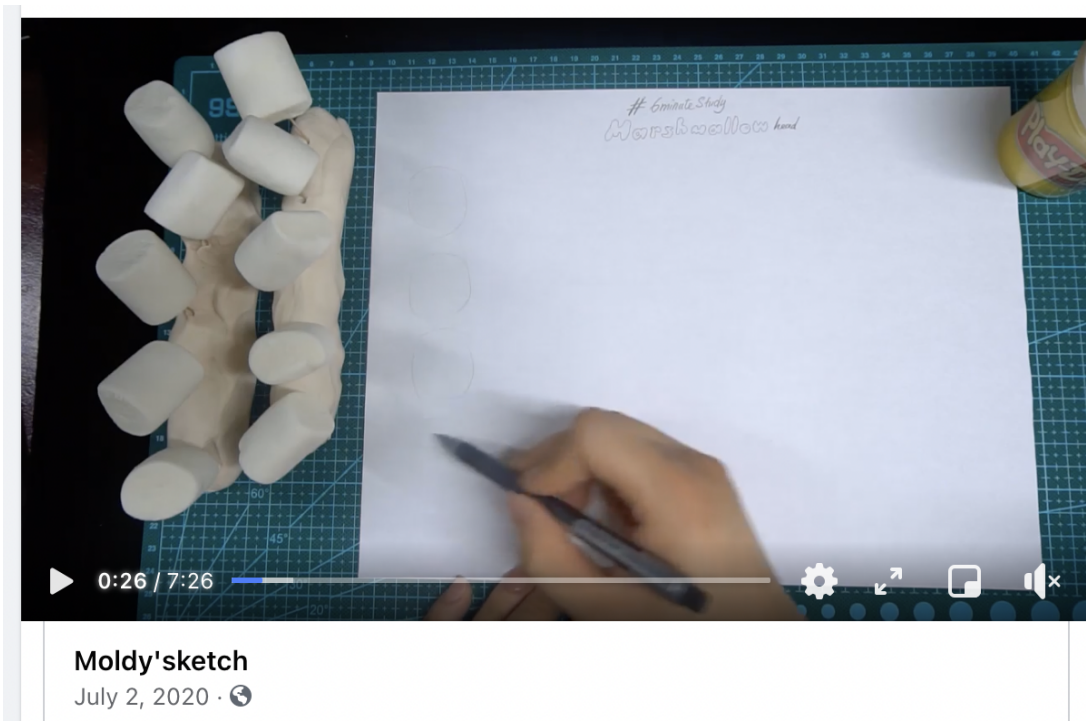

**Bài 5:**  
Vẽ pose dáng khối cơ thể người  
**HW:** vẽ bàn tay

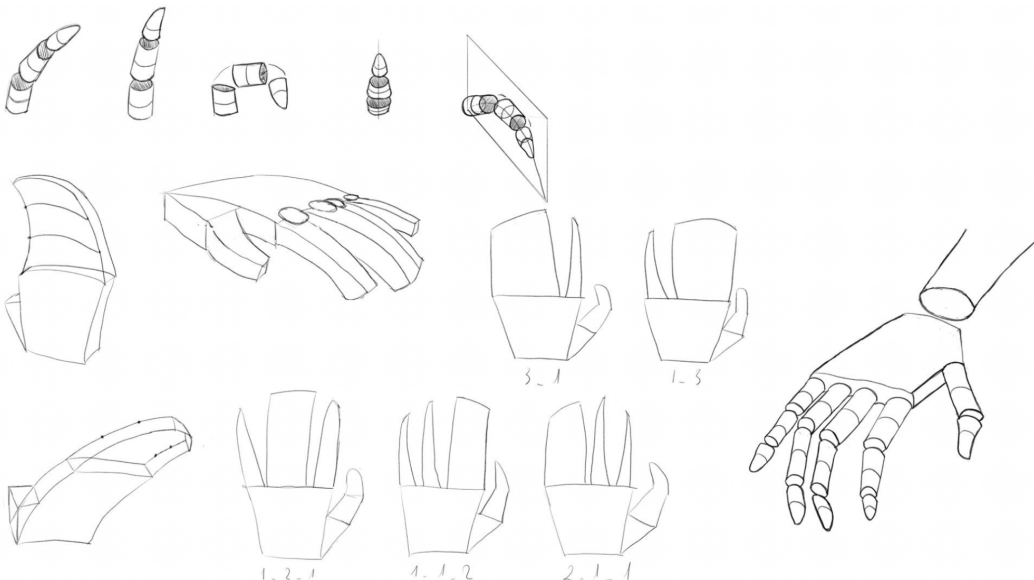
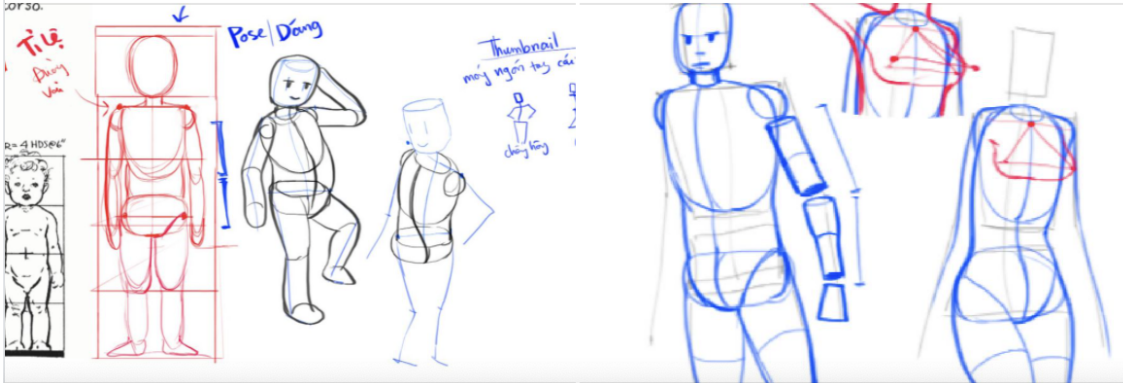
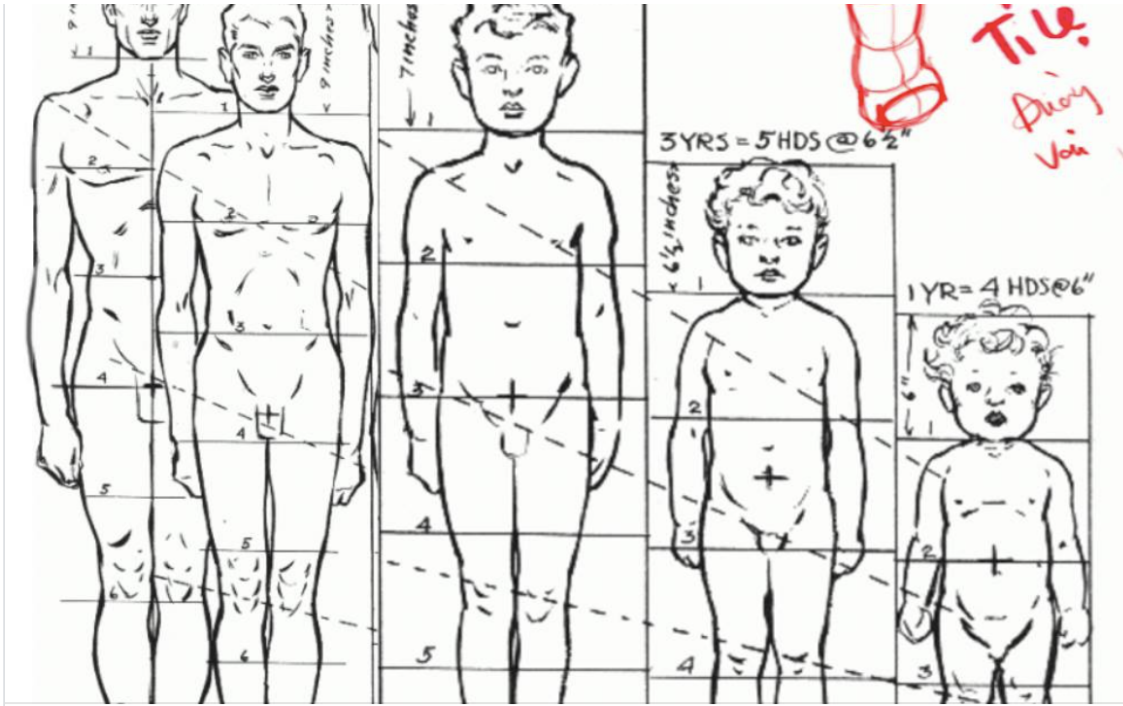

**Bài 6:**

Design bằng phương pháp Re-design một nhân vật

- Chọn nhân vật: (Dumbledore, Harryporter, Conan, Nobita, Luke Skywalker....)
- Vẽ lại nhân vật trong tỉ lệ tựa game Idle Heroes (Đầu to, chân tay ngắn)
- Mặc đồ cho nhân vật, chỉ sử dụng đồ trong game Legend of Zelda



IAMAG.CO

The Legend of Zelda: Breath of the Wild - 100+ Concept Art Collection

