

# **FREEBORN**

**TOOL COMPANY, INC.**



SUPERIOR GEOMETRY ◀

---

PROUDLY MADE IN U.S.A. ◀

---

HIGH LEVEL OF PRECISION  
AND CUSTOMIZATION ◀

---



(800) 523-8988



[WWW.FREEBORNTOOL.COM](http://WWW.FREEBORNTOOL.COM)



# **Freeborn Tool Company has built a reputation on Precision, Repeatability, Value and Customer Support - unequaled in the tooling industry.**

---

Thank you for choosing Freeborn Tool Co. for your tooling needs. Since the 1970's, Freeborn Tool Co. has been a leading manufacturer of shaper cutters in the United States. Throughout the years, Freeborn has become known for the quality of their cutters as well as their ability to make custom tooling to fit the woodworker's requirements, quickly.

As the industry has progressed, Freeborn has kept up with current technology. Hand turning of bodies has been replaced with 5 axis machining centers, and CNC milling centers. No longer are profiles ground using manual profile machines. Instead, state of the art 5-axis profile grinders are used for all profiles, ensuring exact repeatability cutter after cutter.

Freeborn Tool Co. was one of the first cutter manufacturers to offer both carbide and alloy tipping to their cutters. T-alloy is superior in cutting most natural woods. Carbide cuts well with natural wood as well as man made materials.

All Freeborn cutters go through a stringent quality assurance program throughout the manufacturing process. Multiple checks throughout the production process ensure accuracy, balance, and a perfect fit every time. Unlike some of our competition, our Cope and Pattern sets are not just six cutters pulled from the shelf. Each set is individually matched on an optical comparator to guarantee the proper fit.

Initial quality is only the first step at Freeborn. We are available to work with the customer to determine their needs, and our after-sale customer service is of the highest standard. Whether professional or novice we will provide the information you need to resolve any cutter issues you face. Call us to discuss how we can help you.

We offer brazed shaper cutters, insert cutters, spiral inserts, router bits, custom tooling, and tool holders for CNC tooling. If you don't see what you need here, give us a call and we will help you find it.



**F**reeborn Tool Company is proud to present its latest collection of high quality Carbide and T-Alloy tipped shaper cutters. We are confident that here you will find numerous solutions to your woodworking needs. Your input is appreciated.

This catalog depicts all of our stock cutters including new profiles and wood cutting tools.

We list both our MINI-PRO and PRO-LINE series cutters that share the same profile on the same page. Opposite rotation is available at an additional 20% over the suggested list price. Wood samples are shown actual size unless otherwise indicated.

By offering the woodworker a choice in tipping materials, finding the tool best suited for the job becomes simpler.

#### T-ALLOY TIPPED

Freeborn offers a complete line of shaper cutters with T-Alloy tips, uniquely designed for cutting natural woods (not to be used for man-made materials). T-Alloy is one of the most advanced cutting materials on the market today. It is extremely durable to better resist chipping and cracking, as well as corrosion from wood acids. They can also be face-honed between sharpenings for extra long life. T-Alloy cutters are painted bright yellow.

Minor voids in the face of our alloy tips sometimes occur and will not affect the cut qualities.

#### CARBIDE TIPPED

Carbide tipped cutters are still unsurpassed while working with man-made materials such as particle board, plywood and fiberboard, as well as natural wood. The time-tested, orange colored Freeborn cutters offer a geometrically precise design that provides long life and unmatched results in a variety of applications.

#### ORDERING INFORMATION

Product numbers are simple to understand by following the "Product Order Code" interspersed through the catalog.

#### MINI-PRO SERIES

Our 3 wing cutters with a 3/4" bore.

#### PRO-LINE SERIES

Our 3 wing cutters with a 1-1/4" bore.

#### CUSTOM

Of course, if you don't see exactly what you need, please give us a call to discuss custom cutters (see the Custom Made Tooling page in the back of the catalog).

#### RETURN POLICY

All returns to Freeborn Tool Co. must be approved in advance. Returns must be unused and are subject to a 15% restocking fee. Exchanges of unused cutters will be exempt from the 15% restocking fee.

#### CANCELLATIONS

Stock orders may be canceled prior to shipping without penalty. Custom orders will be charged a prorated fee based on completion status.

#### PRODUCT ORDER CODE

<b>M</b>	<b>C</b>	<b>00-000</b>
<b>P</b>	<b>C</b>	<b>00-000</b>
<b>P</b>	<b>T</b>	<b>00-000</b>

<b>M</b> - MINI-PRO	(3/4" Bore)
<b>P</b> - PRO-LINE	(1-1/4" Bore)
<b>C</b> - Carbide Tip	(Orange)
<b>T</b> - T-Alloy Tip	(Yellow)

#### Address:

3304 E. Ferry Ave.  
Spokane, WA 99202

#### Phone:

(509) 484-3033

Toll Free in U.S. and Canada  
1-800-523-8988

#### Fax:

(509) 484-9932

#### E-mail:

sales@freeborntool.com

#### Website:

www.freeborntool.com

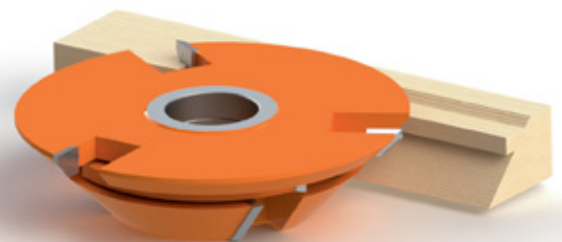

# INSERT TOOLING - COPE AND PATTERN SETS

- Common minor diameters and vertical profile centering eliminate the need to adjust the spindle height or fence position when switching from cope to pattern cuts
- Heads will accept both square and eased edges
- For 3/4" to 7/8" material
- 1/4 x 1/2 tongue and groove standard
- 4-1/2" outside diameter, 3-1/2" minor diameter
- 4" diameter for unique 250/265 available by special order
- 5.5mm x 1/2" tongue available by special order
- 1-1/4" bore
- CCW rotation, material fed face down

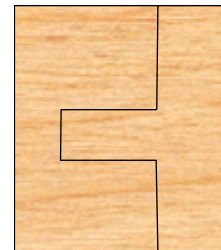

I-10-535

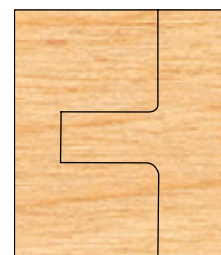

I-10-535-E

For oversized jobs, the IC-10-535 can cut up to 1-1/4" material

## DEDICATED PROFILE INSERT CUTTERS 2 PC. SETS

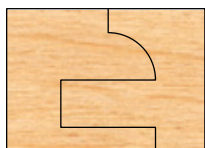

I-10-010-2

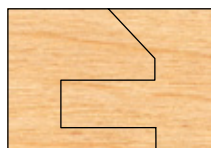

I-10-055-2

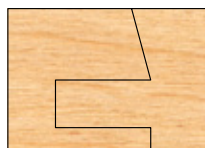

I-10-060-2

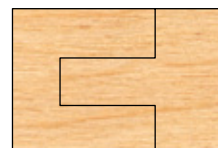

I-10-500

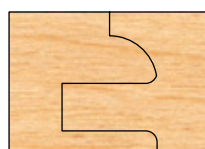

I-10-010-2-E

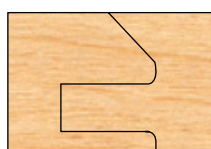

I-10-055-2-E

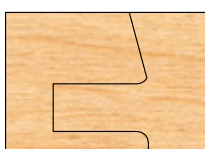

I-10-060-2-E

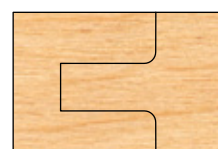

I-10-500-E

## MULTI PROFILE INSERT CUTTERS 2 PC. SETS

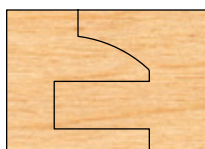

I-10-011-2

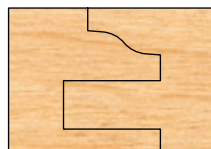

I-10-020-2

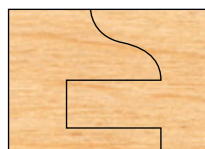

I-10-030-2

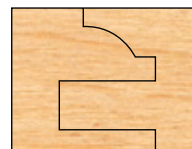

I-10-040-2

Our multi profile head will accept any of these 14 profiles

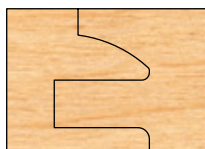

I-10-011-2-E

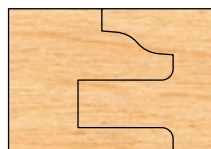

I-10-020-2-E

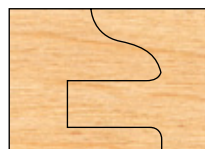

I-10-030-2-E

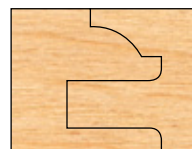

I-10-040-2-E

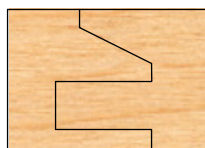

I-10-050-2

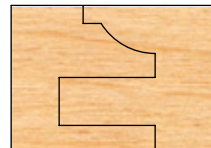

I-10-070-2

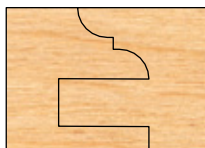

I-10-080-2

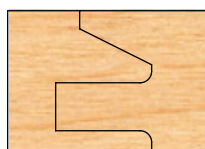

I-10-050-2-E

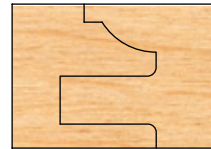

I-10-070-2-E

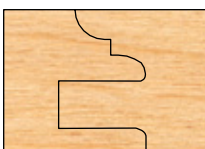

I-10-080-2-E

Our 2 piece Cope and Pattern insert sets do not offer the adjustability of our 3 piece sets. (page 6-7). As a result, it is critical that your spindle be square to your table. (see page 42 for instructions to check your spindle.) Also, when changing your tips you must clean the heads of any wood residue to allow proper alignment. Failure to do so may result in a loose fit between your Cope and Pattern cuts.

# INSERT TOOLING - COPE AND PATTERN SETS

**3 Piece insert Cope and Pattern sets to allow easy fit adjustment.**

- A two piece cope head with shims allow you to adjust your fit as needed
- Common minor diameters and vertical profile centering eliminate the need to adjust the spindle height or fence position when switching from cope to pattern cuts
- Heads will accept both square and eased edges
- For 3/4" 7/8" material
- 4-1/2" outside diameter, 3-1/2" minor diameter
- 4" diameter for unique 250/265 available by special order
- 5.5mm x 1/2" tongue available by special order
- 1-1/4" bore
- 1/4 x 1/2 tongue and groove standard
- CCW rotation, material fed face down

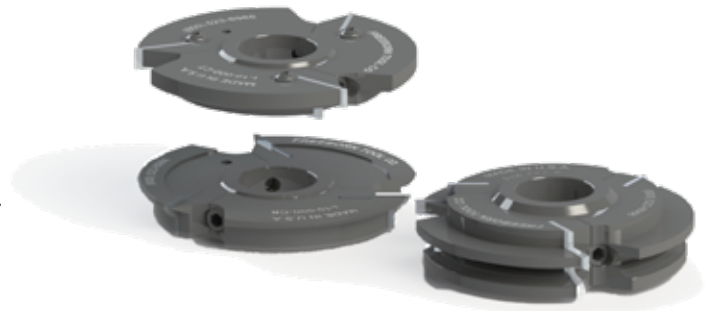

*When changing your tips, you must clean the heads of any wood residue to allow proper alignment. Failure to do so may result in a loose fit between your Cope and Pattern cuts.*

## DEDICATED PROFILE INSERT CUTTERS 3 PC. SETS

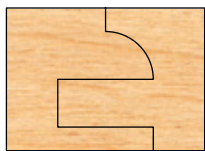

I-10-010

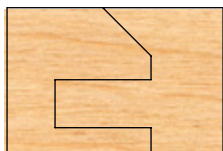

I-10-055

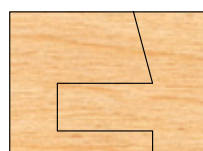

I-10-060

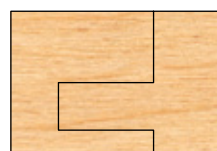

I-10-510

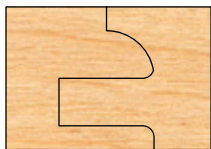

I-10-010 E

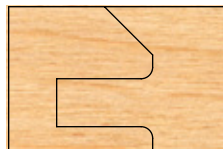

I-10-055-E

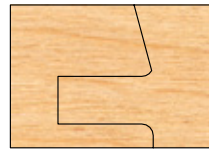

I-10-060-E

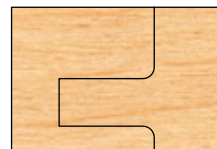

I-10-510-E

***Each of the above profiles has its own dedicated heads***

# INSERT TOOLING - COPE AND PATTERN SETS

## 3 Piece insert Cope and Pattern sets to allow easy fit adjustment.

- A two piece cope head with shims allow you to adjust your fit as needed
- Common minor diameters and vertical profile centering eliminate the need to adjust the spindle height or fence position when switching from cope to pattern cuts
- Heads will accept both square and eased edges
- For 3/4" to 7/8" material
- 4-1/2" outside diameter, 3-1/2" minor diameter
- 4" diameter for unique 250/265 available by special order
- 5.5mm x 1/2" tongue available by special order
- 1-1/4" bore
- 1/4 x 1/2 tongue and groove standard
- CCW rotation, material fed face down



*When changing your tips, you must clean the heads of any wood residue to allow proper alignment. Failure to do so may result in a loose fit between your Cope and Pattern cuts.*

## MULTI PROFILE INSERT CUTTERS 3 PC. SETS

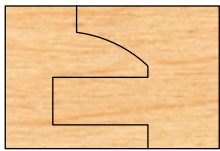

I-10-011

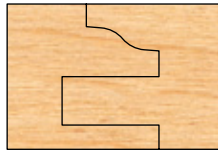

I-10-020

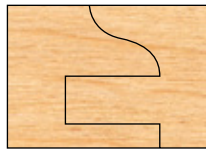

I-10-030

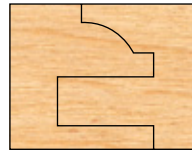

I-10-040

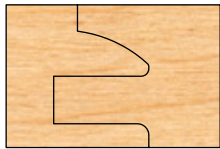

I-10-011-E

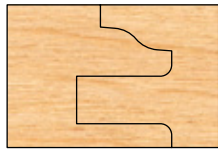

I-10-020-E

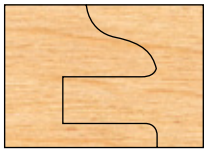

I-10-030-E

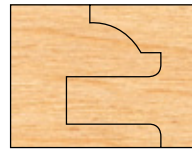

I-10-040-E

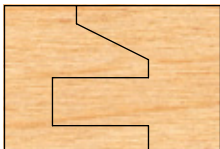

I-10-050

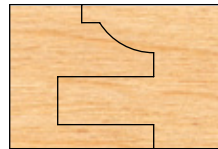

I-10-070

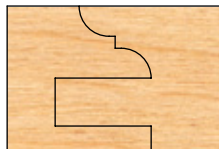

I-10-080

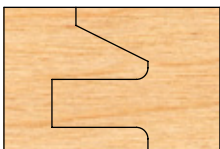

I-10-050-E

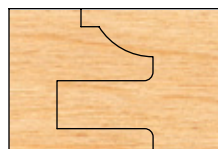

I-10-070-E

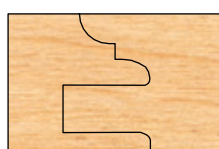

I-10-080-E



*Our multi-profile head will accept any of these 14 profiles*

# INSERT TOOLING - COPE AND PATTERN SETS

For a more pronounced profile, our 1/2" depth of pattern sets are a great choice, with all of the benefits of our other sets. The tip sets of these profiles are not interchangeable with our other 3 piece sets.

## 3 Piece insert Cope and Pattern sets to allow easy fit adjustment.

- Common minor diameters and vertical Profile Centering eliminate the need to adjust the spindle height or fence position when switching from cope to pattern cuts
- Heads will accept both square and eased edges
- For 3/4" 7/8" material
- 4-1/2" outside diameter, 3-1/2" minor diameter
- 4" diameter for unique 250/265 available by special order
- 5.5mm x 1/2" tongue available by special order
- 1-1/4" bore
- 1/4 x 1/2 tongue and groove standard
- CCW rotation, material fed face down

*When changing your tips, you must clean the heads of any wood residue to allow proper alignment. Failure to do so may result in a loose fit between your Cope and Pattern cuts.*

## MULTI PROFILE INSERT CUTTERS 3 PIECE - 1/2" DEPTH OF PATTERN

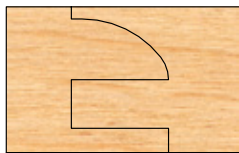

I-10-211

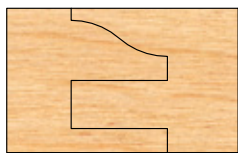

I-10-220

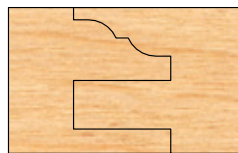

I-10-225

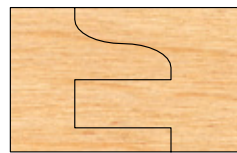

I-10-231

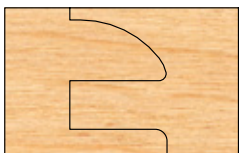

I-10-211-E

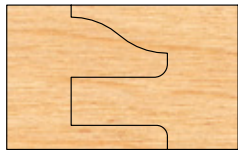

I-10-220-E

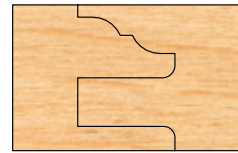

I-10-225-E

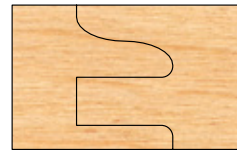

I-10-231-E

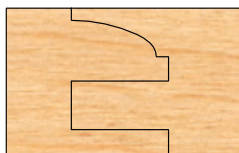

I-10-240

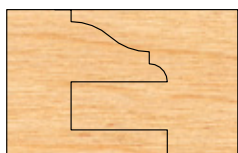

I-10-245

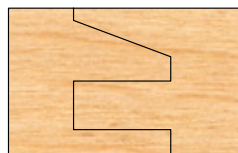

I-10-250

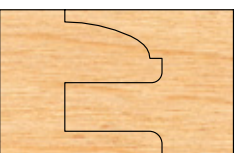

I-10-240-E

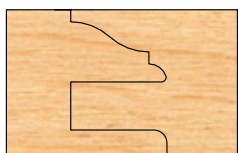

I-10-245-E

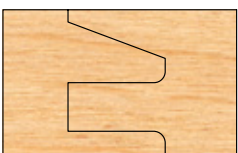

I-10-250-E

*Our multi profile head will accept any of these 14 profiles*



## RAISED PANEL INSERT CUTTERS (3/4" MATERIAL)

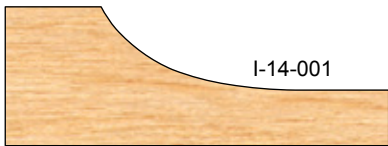

I-14-001



I-14-002

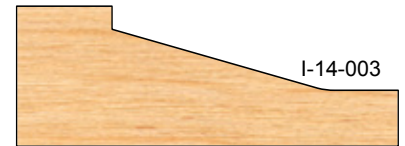

I-14-003

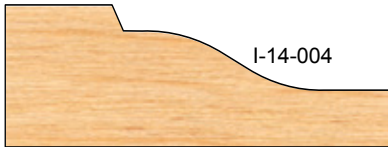

I-14-004

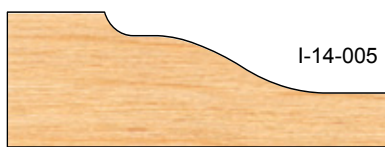

I-14-005

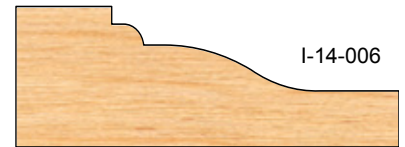

I-14-006

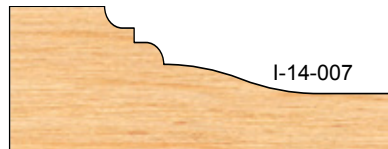

I-14-007



I-14-009



I-14-011



I-14-013

- 3 wing
- 1-1/4" bore
- 6" diameter
- Runs with (AP-90-048) bearing
- CCW, material fed face up

- These are dedicated profile heads (one profile per head)

## RAISED PANEL INSERT CUTTERS (5/8" MATERIAL)



I-15-001



I-15-002



I-15-003



I-15-004



I-15-005



I-15-006

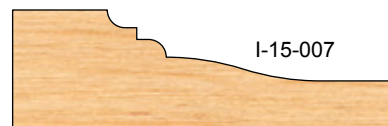

I-15-007



I-15-009



I-15-011

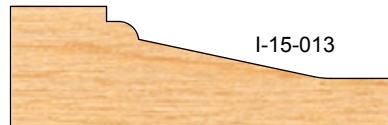

I-15-013

- 3 wing
- 1-1/4" bore
- 6" diameter
- Use with I-16-001 for 3/4" material
- Runs with (AP-90-048) bearing

- CCW, material fed face up
- These are dedicated profile heads (one profile per head)

## INSERT BACK & TRIM CUTTERS

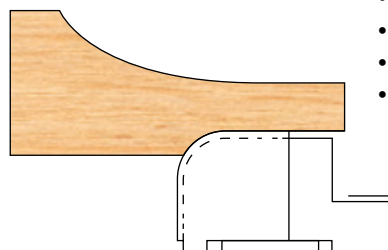

- 3 wing
- 1-1/4" bore
- 4-3/4" diameter
- 3/4" material
- Runs with a(I-15-xxx) panel cutter

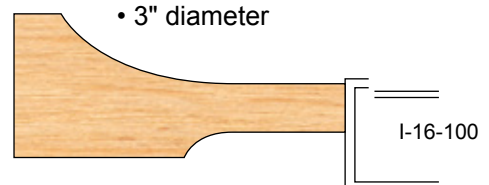

- 3 wing
- 1-1/4" bore
- 3" diameter

CARBIDE ONLY

## DEDICATED DOOR EDGE DETAIL INSERT CUTTERS

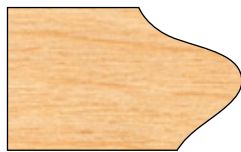

I-17-001



I-17-002



I-17-032



I-17-101



I-17-110



I-17-113



I-17-114

- 3 wing
- 1-1/4" bore
- 3-1/2" minor diameter
- 30 mm tips
- CCW, material fed face up
- These are dedicated profile heads (one profile per head)

## REVERSIBLE GLUE JOINT INSERT CUTTER



I-18-001

- Creates an incredibly strong joint by interlocking the glue surfaces
- 3 wing
- 3-1/2" minor diameter
- 1-1/4" bore
- Cuts from 1/2" to 1-7/8" material
- 50 mm tips
- CCW, fed as shown

## FLOORING SET INSERT CUTTERS 2 PC. SETS

I-19-030

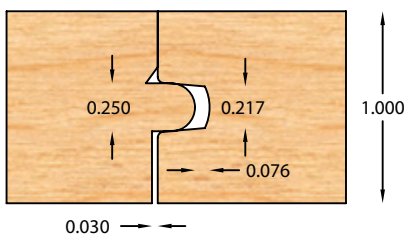

- 3 wing
- 1-1/4" bore
- 3-1/2" minor diameter
- Cuts up to 1" material
- 30 mm tips
- CCW, material fed face down



I-19-500

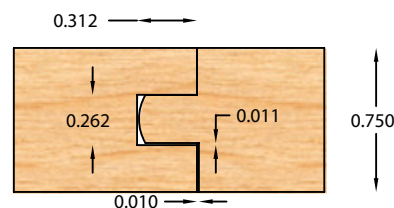

- 3 wing
- 1-1/4" bore
- 3-1/2" minor diameter
- 30 mm tips
- Cuts up to 1" material
- CCW, material fed face down

## STRAIGHT CUTTER INSERTS

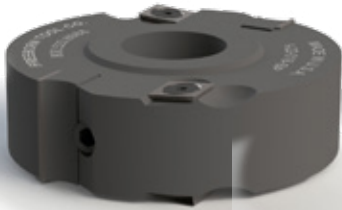

### IC-22-016-SP

- 4" Outer Diameter
- 1-1/4" Bore
- 30mm Tip: IC-0300-050
- Spur: IC-0140-060

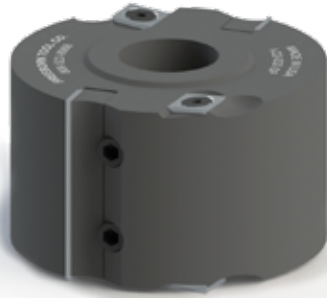

### IC-22-032-SP

- 4" Outer Diameter
- 1-1/4" Bore
- 60mm Tip: IC-0600-050
- Spur: IC-0140-060

Using standard 30mm or 60mm carbide inserts, this is an easy and inexpensive way to perform trim or rabbet cuts.

*PLEASE NOTE: spurs are required for all cuts except trimming.*

## STRAIGHT CUTTER INSERTS



### IC-22-ADJ

2 piece expandable groover set using 14 x 14 inserts. Set your cut from 12.5mm - 24mm by using the included spacer or shims.

- 6" outer diameter
- 1-1/4" Bore
- 4 cutting / 4 spur
- Tip: IC-0120-050
- Spur: IC-0140-060

## SPIRAL CUTTERS INSERTS WITH SPURS

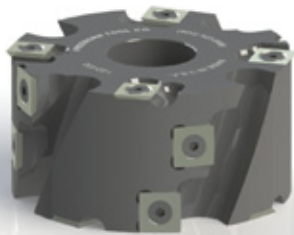

### IS-22-032-SP

- 4" Outer Diameter
- 1-1/4" Bore
- 4 Wing
- 2" Height
- Aluminum Body
- Tip: IC-0150-060
- Spur: IC-0140-060

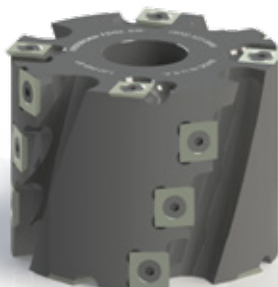

### IS-22-048-SP

- 4" Outer Diameter
- 1-1/4" Bore
- 4 Wing
- 3" Height
- Aluminum Body
- Tip: IC-0150-060
- Spur: IC-0140-060



### IS-22-064-SP

- 4" Outer Diameter
- 1-1/4" Bore
- 4 Wing
- 4" Height
- Aluminum Body
- Tip: IC-0150-060
- Spur: IC-0140-060

# BRAZED TOOLING

## COPE & PATTERN (6 Piece Cutter Sets)

Versatile and easy-to-use. These 6 piece cutter sets are designed to perform the 3 functions shown. Our standard sets cut 1/4" wide x 3/8" deep tongue and groove.

Our common minor diameter requires NO fence adjustment when changing from cope to pattern cuts (3/8" tongue only).

Counterclockwise rotation with wood fed face down.

For optional tongue and groove cutters and eased edge option, see page 13 and 14.

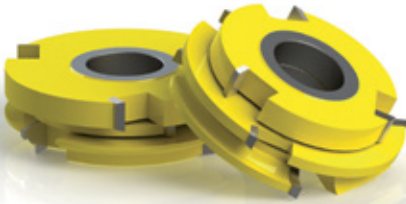

For **opposite rotation**, add 20% to the suggested list price.

To order **custom profiles**, see our Custom Made Tooling page in the back of the catalog. Same day quoting.

Wood samples shown actual size.

For eased edges add 20% to the suggested list price.

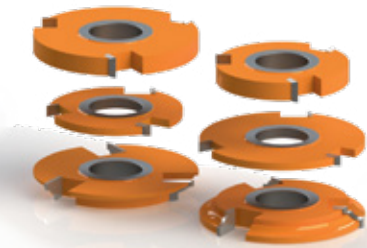

See stacking instructions on page 42.

### MINI-PRO cutters

- 3 wing • 2-15/16" diameter
- 3/4" bore • Runs with a 2-3/16" diameter rub bearing (AM-90-035)
- CCW, material face down

### PRO-LINE cutters

- 3 wing • 4" diameter
- 1-1/4" bore • Runs with a 3-1/4" diameter rub bearing (AP-90-052)

#### Cope & Pattern 3/4" to 1-1/8" material

M C	50-010
P C	10-010
P T	10-010

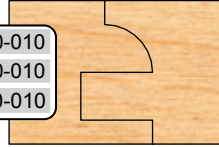

M C	50-015
P C	10-015
P T	10-015

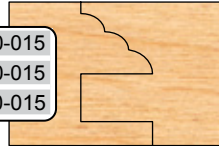

M C	50-020
P C	10-020
P T	10-020

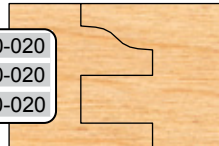

M C	50-025
P C	10-025
P T	10-025

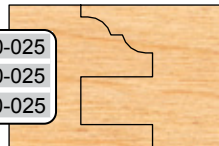

M C	50-030
P C	10-030
P T	10-030

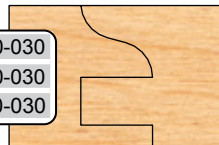

M C	50-035
P C	10-035
P T	10-035

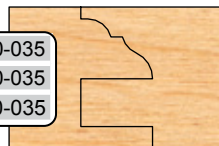

M C	50-040
P C	10-040
P T	10-040

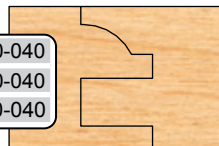

M C	50-045
P C	10-045
P T	10-045

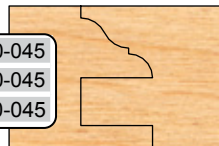

M C	50-050
P C	10-050
P T	10-050

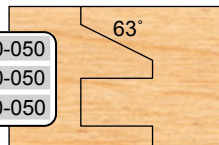

#### Glass Panel 3/4" to 7/8" material

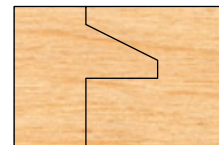
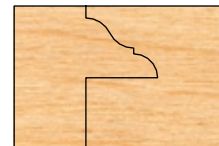
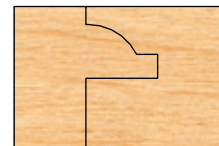
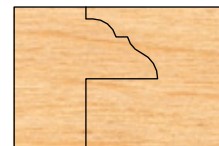
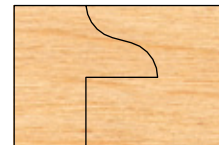
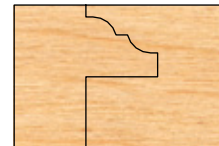
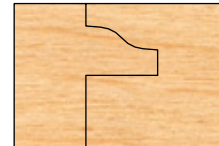
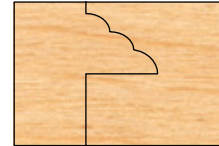
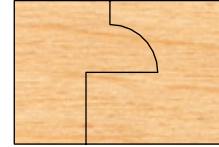

#### Tongue & Groove 3/4" material

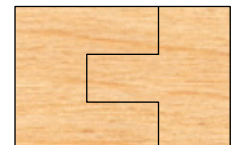
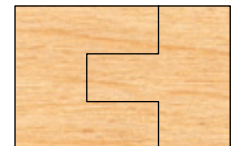
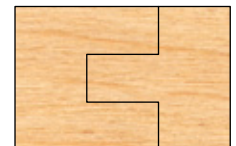
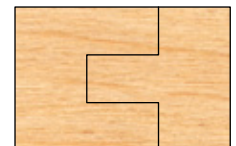
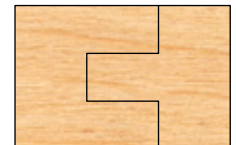
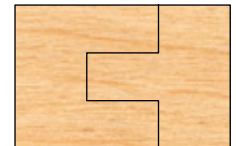
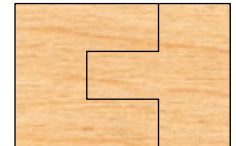
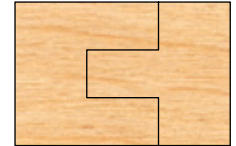
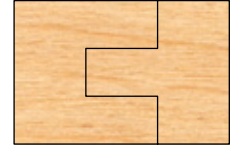

# COPE & PATTERN (6 Piece Cutter Sets)

## PRODUCT ORDER CODE

<b>M</b>	<b>C</b>	<b>00-000</b>
<b>P</b>	<b>C</b>	<b>00-000</b>
<b>P</b>	<b>T</b>	<b>00-000</b>

<b>M</b> - MINI-PRO	(3/4" Bore)
<b>P</b> - PRO-LINE	(1-1/4" Bore)
<b>C</b> - Carbide Tip	(Orange)
<b>T</b> - T-Alloy Tip	(Yellow)

**Cope & Pattern**  
3/4" to 1-1/8" material

**Glass Panel**  
3/4" to 7/8" material

**Tongue & Groove**  
3/4" material

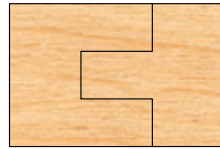
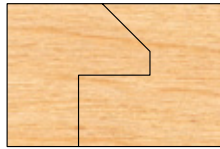
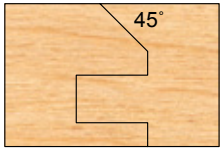

<b>M</b>	<b>C</b>	50-055
<b>P</b>	<b>C</b>	10-055
<b>P</b>	<b>T</b>	10-055

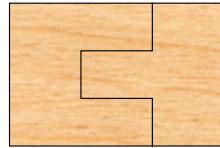
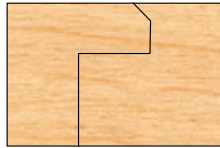
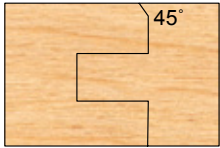

<b>M</b>	<b>C</b>	50-058
<b>P</b>	<b>C</b>	10-058
<b>P</b>	<b>T</b>	10-058

See stacking instructions on page 42.

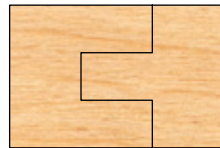
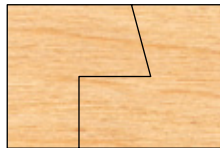
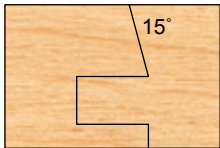

<b>M</b>	<b>C</b>	50-060
<b>P</b>	<b>C</b>	10-060
<b>P</b>	<b>T</b>	10-060

For opposite rotation, add 20% to the suggested list price.

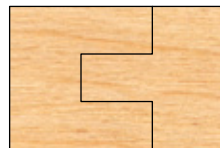
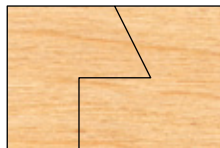
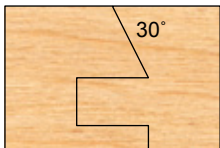

<b>M</b>	<b>C</b>	50-065
<b>P</b>	<b>C</b>	10-065
<b>P</b>	<b>T</b>	10-065

To order custom profiles, see our Custom Made Tooling page in the back of the catalog. Same day quoting.

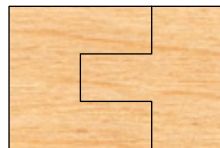
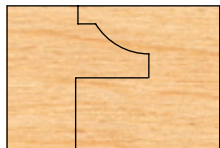
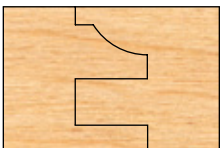

<b>M</b>	<b>C</b>	50-070
<b>P</b>	<b>C</b>	10-070
<b>P</b>	<b>T</b>	10-070

Wood samples shown actual size.

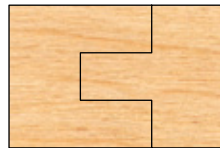
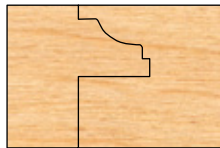
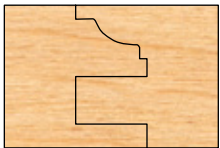

<b>M</b>	<b>C</b>	50-075
<b>P</b>	<b>C</b>	10-075
<b>P</b>	<b>T</b>	10-075

For eased edges add 20% to the suggested list price.

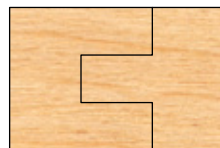
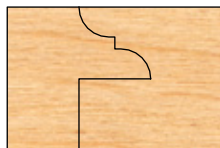
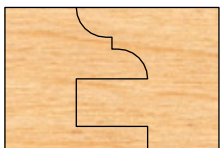

<b>M</b>	<b>C</b>	50-080
<b>P</b>	<b>C</b>	10-080
<b>P</b>	<b>T</b>	10-080

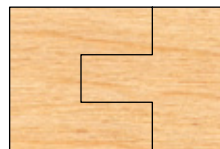
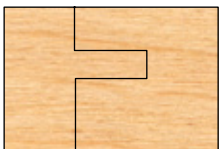
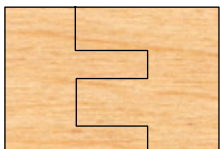

<b>M</b>	<b>C</b>	50-090
<b>P</b>	<b>C</b>	10-090
<b>P</b>	<b>T</b>	10-090

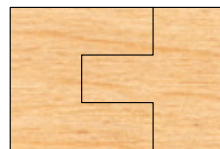
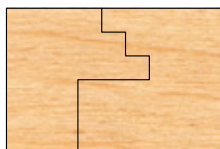
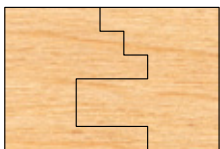

<b>M</b>	<b>C</b>	50-091
<b>P</b>	<b>C</b>	10-091
<b>P</b>	<b>T</b>	10-091

# COPE & PATTERN (6 Piece Cutter Sets)

## MINI-PRO cutters

- 3 wing • 2-15/16" diameter
- 3/4" bore • Runs with a 2-3/16" diameter rub bearing (AM-90-035)
- CCW, material face down

## PRO-LINE cutters

- 3 wing • 4" diameter
- 1-1/4" bore • Runs with a 3-1/4" diameter rub bearing (AP-90-052)

**Cope & Pattern**  
3/4" to 1-1/8" material

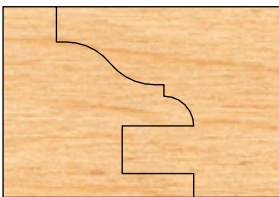
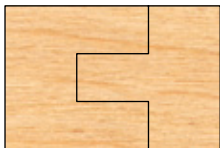
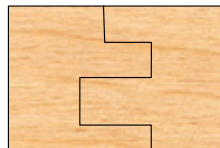
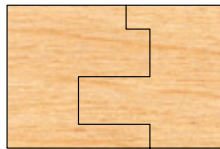

**Glass Panel**  
3/4" to 7/8" material

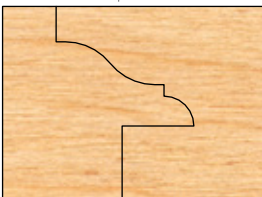
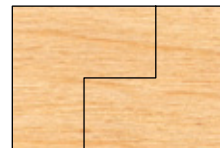
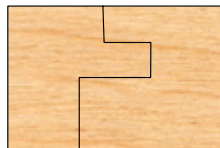
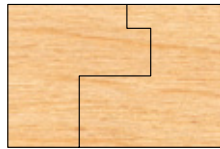

**Tongue & Groove**  
3/4" material

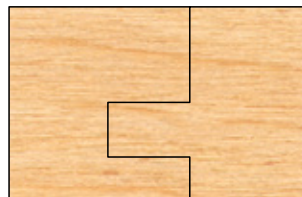
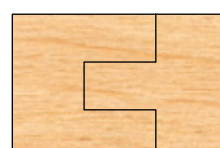
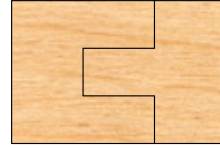
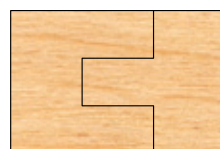

**M C** 50-092  
**P C** 10-092  
**P T** 10-092

**M C** 50-093  
**P C** 10-093  
**P T** 10-093

**M C** 50-500  
**P C** 10-500  
**P T** 10-500

**M C** 50-145  
**P C** 10-145  
**P T** 10-145

For 1.00" to 1 3/8" material

# OPTIONAL EASED EDGE SETS

Eased edges are available on all 10 and 50 series cope and patterns. However, you cannot do glass panel or tongue and groove without optional groovers from page 14. Add 20% to the suggested list price.

**PLEASE NOTE: Freeborn Tool Co. will be not responsible for bent center groovers due to incorrect stacking. Be sure to read the stacking instructions included with your cutters.**

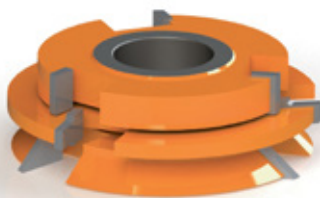

**REMEMBER:** Always stagger cutters when stacking. Never stack wing-to-wing or you will bend the center groover.

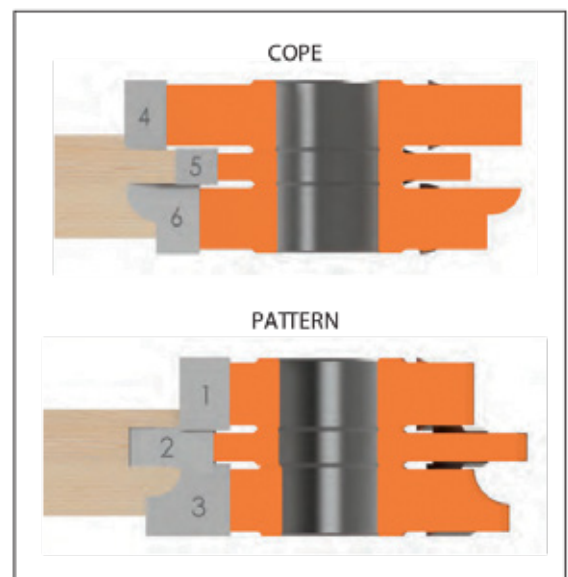

## CENTER GROOVER SETS (2 Piece Cutter Sets)

At time of purchase, you may substitute the following tongue & groove cutters for the standard tongue & groove cutters in your cope & pattern set, at no additional charge. If you choose an optional center groover set other than 3/8" depth, you will be unable to do the tongue & groove option.

Available on all M-50 and P-10 series cope & patterns.

For options other than 3/8" depth, diameters will no longer be the same, requiring fence adjustments between cuts.

**PRODUCT ORDER CODE**

M	C	00-000	M - MINI-PRO	(3/4" Bore)
P	C	00-000	P - PRO-LINE	(1-1/4" Bore)
P	T	00-000	C - Carbide Tip	(Orange)
			T - T-Alloy Tip	(Yellow)

### Center Groovers Only - Profile cutters not included

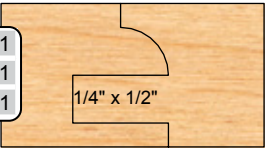
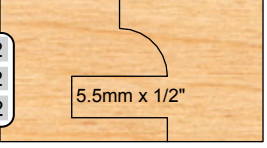
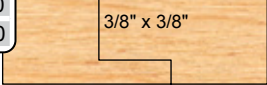
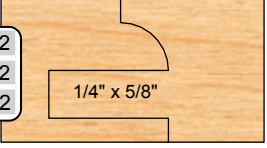
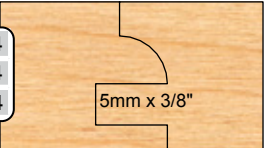
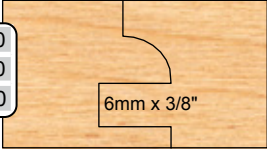
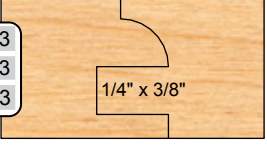
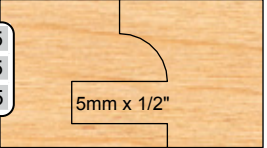
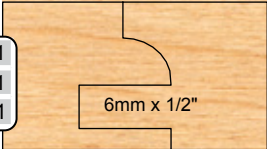
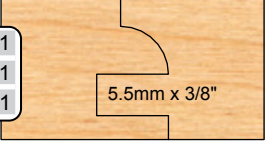
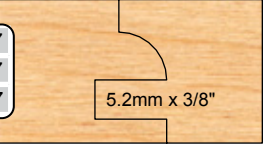
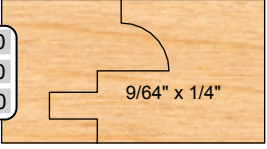
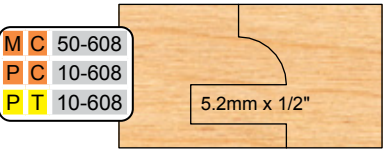
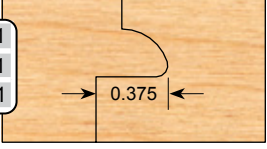
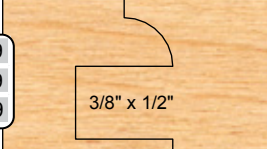
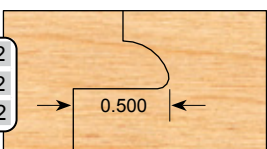
<table border="1"> <tr><td>M</td><td>C</td><td>50-501</td></tr> <tr><td>P</td><td>C</td><td>10-501</td></tr> <tr><td>P</td><td>T</td><td>10-501</td></tr> </table>  <p>1/4" x 1/2"</p>	M	C	50-501	P	C	10-501	P	T	10-501	<table border="1"> <tr><td>M</td><td>C</td><td>50-602</td></tr> <tr><td>P</td><td>C</td><td>10-602</td></tr> <tr><td>P</td><td>T</td><td>10-602</td></tr> </table>  <p>5.5mm x 1/2"</p>	M	C	50-602	P	C	10-602	P	T	10-602	<table border="1"> <tr><td>M</td><td>C</td><td>50-610</td></tr> <tr><td>P</td><td>C</td><td>10-610</td></tr> <tr><td>P</td><td>T</td><td>10-610</td></tr> </table>  <p>3/8" x 3/8"</p>	M	C	50-610	P	C	10-610	P	T	10-610
M	C	50-501																											
P	C	10-501																											
P	T	10-501																											
M	C	50-602																											
P	C	10-602																											
P	T	10-602																											
M	C	50-610																											
P	C	10-610																											
P	T	10-610																											
<table border="1"> <tr><td>M</td><td>C</td><td>50-502</td></tr> <tr><td>P</td><td>C</td><td>10-502</td></tr> <tr><td>P</td><td>T</td><td>10-502</td></tr> </table>  <p>1/4" x 5/8"</p>	M	C	50-502	P	C	10-502	P	T	10-502	<table border="1"> <tr><td>M</td><td>C</td><td>50-604</td></tr> <tr><td>P</td><td>C</td><td>10-604</td></tr> <tr><td>P</td><td>T</td><td>10-604</td></tr> </table>  <p>5mm x 3/8"</p>	M	C	50-604	P	C	10-604	P	T	10-604	<table border="1"> <tr><td>M</td><td>C</td><td>50-640</td></tr> <tr><td>P</td><td>C</td><td>10-640</td></tr> <tr><td>P</td><td>T</td><td>10-640</td></tr> </table>  <p>6mm x 3/8"</p>	M	C	50-640	P	C	10-640	P	T	10-640
M	C	50-502																											
P	C	10-502																											
P	T	10-502																											
M	C	50-604																											
P	C	10-604																											
P	T	10-604																											
M	C	50-640																											
P	C	10-640																											
P	T	10-640																											
<table border="1"> <tr><td>M</td><td>C</td><td>50-503</td></tr> <tr><td>P</td><td>C</td><td>10-503</td></tr> <tr><td>P</td><td>T</td><td>10-503</td></tr> </table>  <p>1/4" x 3/8"</p>	M	C	50-503	P	C	10-503	P	T	10-503	<table border="1"> <tr><td>M</td><td>C</td><td>50-605</td></tr> <tr><td>P</td><td>C</td><td>10-605</td></tr> <tr><td>P</td><td>T</td><td>10-605</td></tr> </table>  <p>5mm x 1/2"</p>	M	C	50-605	P	C	10-605	P	T	10-605	<table border="1"> <tr><td>M</td><td>C</td><td>50-641</td></tr> <tr><td>P</td><td>C</td><td>10-641</td></tr> <tr><td>P</td><td>T</td><td>10-641</td></tr> </table>  <p>6mm x 1/2"</p>	M	C	50-641	P	C	10-641	P	T	10-641
M	C	50-503																											
P	C	10-503																											
P	T	10-503																											
M	C	50-605																											
P	C	10-605																											
P	T	10-605																											
M	C	50-641																											
P	C	10-641																											
P	T	10-641																											
<table border="1"> <tr><td>M</td><td>C</td><td>50-601</td></tr> <tr><td>P</td><td>C</td><td>10-601</td></tr> <tr><td>P</td><td>T</td><td>10-601</td></tr> </table>  <p>5.5mm x 3/8"</p>	M	C	50-601	P	C	10-601	P	T	10-601	<table border="1"> <tr><td>M</td><td>C</td><td>50-607</td></tr> <tr><td>P</td><td>C</td><td>10-607</td></tr> <tr><td>P</td><td>T</td><td>10-607</td></tr> </table>  <p>5.2mm x 3/8"</p>	M	C	50-607	P	C	10-607	P	T	10-607	<p><b>Glass option</b> (for rubber extrusion)</p> <table border="1"> <tr><td>M</td><td>C</td><td>50-700</td></tr> <tr><td>P</td><td>C</td><td>10-700</td></tr> <tr><td>P</td><td>T</td><td>10-700</td></tr> </table>  <p>9/64" x 1/4"</p>	M	C	50-700	P	C	10-700	P	T	10-700
M	C	50-601																											
P	C	10-601																											
P	T	10-601																											
M	C	50-607																											
P	C	10-607																											
P	T	10-607																											
M	C	50-700																											
P	C	10-700																											
P	T	10-700																											
<table border="1"> <tr><td>M</td><td>C</td><td>50-608</td></tr> <tr><td>P</td><td>C</td><td>10-608</td></tr> <tr><td>P</td><td>T</td><td>10-608</td></tr> </table>  <p>5.2mm x 1/2"</p>	M	C	50-608	P	C	10-608	P	T	10-608	<table border="1"> <tr><td>M</td><td>C</td><td>50-701</td></tr> <tr><td>P</td><td>C</td><td>10-701</td></tr> <tr><td>P</td><td>T</td><td>10-701</td></tr> </table> <p>Eased Edge Glass Groover Pattern Side Groover only</p>  <p>0.375</p>	M	C	50-701	P	C	10-701	P	T	10-701										
M	C	50-608																											
P	C	10-608																											
P	T	10-608																											
M	C	50-701																											
P	C	10-701																											
P	T	10-701																											
<table border="1"> <tr><td>M</td><td>C</td><td>50-609</td></tr> <tr><td>P</td><td>C</td><td>10-609</td></tr> <tr><td>P</td><td>T</td><td>10-609</td></tr> </table>  <p>3/8" x 1/2"</p>	M	C	50-609	P	C	10-609	P	T	10-609	<table border="1"> <tr><td>M</td><td>C</td><td>50-702</td></tr> <tr><td>P</td><td>C</td><td>10-702</td></tr> <tr><td>P</td><td>T</td><td>10-702</td></tr> </table> <p>Eased Edge Glass Groover Pattern Side Groover only</p>  <p>0.500</p>	M	C	50-702	P	C	10-702	P	T	10-702										
M	C	50-609																											
P	C	10-609																											
P	T	10-609																											
M	C	50-702																											
P	C	10-702																											
P	T	10-702																											

## SPLIT GROOVER SETS (4 Piece Cutter Sets)

These 4 piece split groover sets are used in the 10 and 50 series cope and pattern sets to allow you to cut between 3/16" and just under 3/8" with shims.

NOTE: Provides adjustment for spindle alignment issues. Exchange for standard center groovers for an additional fee.

3/8" Depth	<table border="1"> <tr><td>M</td><td>C</td><td>50-403</td></tr> <tr><td>P</td><td>C</td><td>10-403</td></tr> <tr><td>P</td><td>T</td><td>10-403</td></tr> </table>	M	C	50-403	P	C	10-403	P	T	10-403	<table border="1"> <tr><td>M</td><td>C</td><td>50-403</td><td>E</td><td>E</td></tr> <tr><td>P</td><td>C</td><td>10-403</td><td>E</td><td>E</td></tr> <tr><td>P</td><td>T</td><td>10-403</td><td>E</td><td>E</td></tr> </table>	M	C	50-403	E	E	P	C	10-403	E	E	P	T	10-403	E	E
M	C	50-403																								
P	C	10-403																								
P	T	10-403																								
M	C	50-403	E	E																						
P	C	10-403	E	E																						
P	T	10-403	E	E																						
1/2" Depth	<table border="1"> <tr><td>M</td><td>C</td><td>50-401</td></tr> <tr><td>P</td><td>C</td><td>10-401</td></tr> <tr><td>P</td><td>T</td><td>10-401</td></tr> </table>	M	C	50-401	P	C	10-401	P	T	10-401	<table border="1"> <tr><td>M</td><td>C</td><td>50-401</td><td>E</td><td>E</td></tr> <tr><td>P</td><td>C</td><td>10-401</td><td>E</td><td>E</td></tr> <tr><td>P</td><td>T</td><td>10-401</td><td>E</td><td>E</td></tr> </table>	M	C	50-401	E	E	P	C	10-401	E	E	P	T	10-401	E	E
M	C	50-401																								
P	C	10-401																								
P	T	10-401																								
M	C	50-401	E	E																						
P	C	10-401	E	E																						
P	T	10-401	E	E																						



# COPE & PATTERN (6 Piece Cutter Sets)

## MINI-PRO cutters

- 3 wing • 3.19" diameter
- 3/4" bore • Runs with rub bearing (AM-90-035)
- CCW, material face down

## PRO-LINE cutters

- 3 wing • 4.25" diameter
- 1-1/4" bore • Runs with a rub bearing (AP-90-052)

## 1/2" DEPTH OF PATTERN

### Deeper Profile Sets

Versatile and easy-to-use.

These 6 piece cutter sets are designed to perform the 3 functions shown. Our standard sets cut 1/4" wide by 1/2" deep tongue and groove.

Our common minor diameter requires NO fence adjustment when changing from cope to pattern cuts. (1/2" tongue only)

Counterclockwise rotation with wood fed face down.

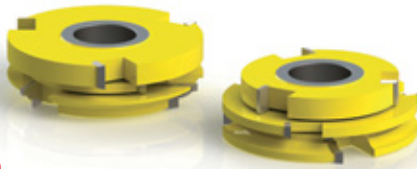

**Cope & Pattern**  
3/4" to 1-1/8" material

**M C** 50-211  
**P C** 10-211  
**P T** 10-211

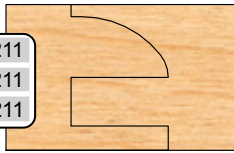

**Glass Panel**  
3/4" to 7/8" material

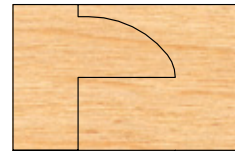

**Tongue & Groove**  
3/4" material

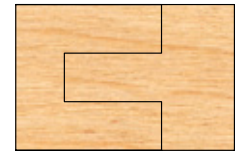

**M C** 50-220  
**P C** 10-220  
**P T** 10-220

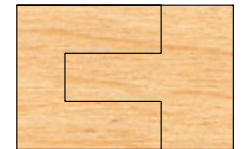
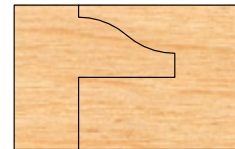
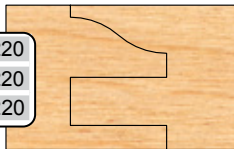

**M C** 50-225  
**P C** 10-225  
**P T** 10-225

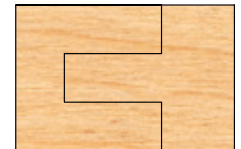
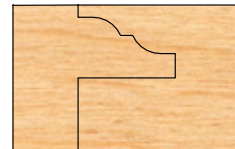
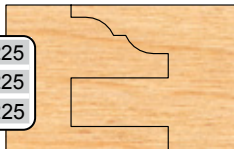

**M C** 50-231  
**P C** 10-231  
**P T** 10-231

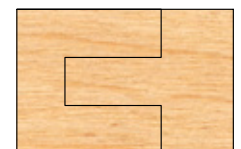
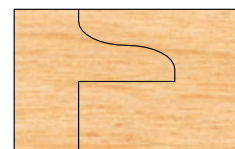
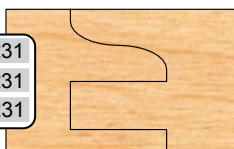

For opposite rotation add 20% to the suggested list price.

Wood samples shown actual size.

For eased edges add 20% to the suggested list price.

See page 13 for eased edge information

**M C** 50-240  
**P C** 10-240  
**P T** 10-240

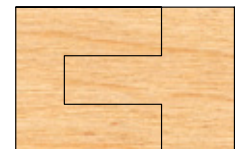
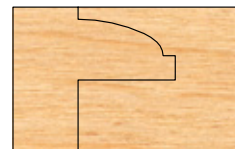
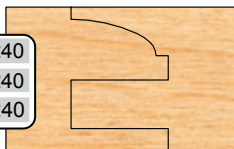

**M C** 50-245  
**P C** 10-245  
**P T** 10-245

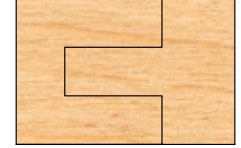
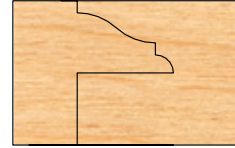
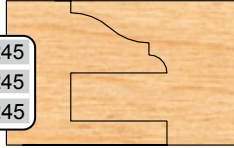

**M C** 50-250  
**P C** 10-250  
**P T** 10-250

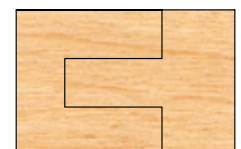
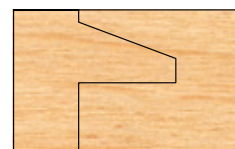
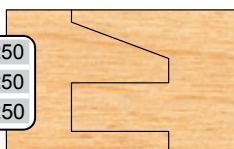

**M C** 50-290  
**P C** 10-290  
**P T** 10-290

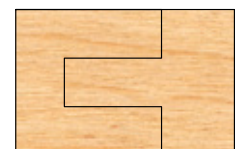
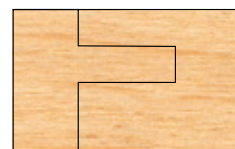
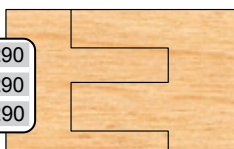

See page 16 for Tongue and Groove options

## CENTER GROOVER SETS (2 Piece Cutter Sets)

### PRODUCT ORDER CODE

**M C** 00-000

**P C** 00-000

**P T** 00-000

M - MINI-PRO (3/4" Bore)  
 P - PRO-LINE (1-1/4" Bore)  
 C - Carbide Tip (Orange)  
 T - T-Alloy Tip (Yellow)

## For 1/2" DEPTH OF PROFILE SETS (page 15)

At time of purchase, you may substitute the following tongue & groove cutters for the standard tongue & groove cutters in your cope & pattern

### Center Groovers Only - Profile cutters not included



To order **custom profiles**, see our Custom Made Tooling page in the back of the catalog. Same day quoting.

<p><b>M C</b> 50-621  <b>P C</b> 10-621  <b>P T</b> 10-621</p>		<p><b>M C</b> 50-625  <b>P C</b> 10-625  <b>P T</b> 10-625</p>	
<p><b>M C</b> 50-622  <b>P C</b> 10-622  <b>P T</b> 10-622</p>		<p><b>M C</b> 50-626  <b>P C</b> 10-626  <b>P T</b> 10-626</p>	
<p><b>M C</b> 50-623  <b>P C</b> 10-623  <b>P T</b> 10-623</p>		<p><b>M C</b> 200-700  <b>P C</b> 200-700  <b>P T</b> 200-700</p>	
<p><b>M C</b> 50-624  <b>P C</b> 10-624  <b>P T</b> 10-624</p>		<p><b>M C</b> 200-700-E  <b>P C</b> 200-700-E  <b>P T</b> 200-700-E</p>	

## SPLIT GROOVER SET

## For 1/2" DEPTH OF PROFILE SETS (page 15)

These 4 piece split groover sets are used in the 10 and 50 series cope and pattern sets to allow you to cut between 3/16" and just under 3/8" with shims.

*NOTE: Provides adjustment for spindle alignment issues. Exchange for standard center groovers for an additional fee.*

1/2" Depth	<b>M C</b> 50-402	<b>M C</b> 50-402-EE
	<b>P C</b> 10-402	<b>P C</b> 10-402-EE
	<b>P T</b> 10-402	<b>P T</b> 10-402-EE



## DOUBLE SIDED COPE & PATTERN (8 Piece Cutter Sets)

### MINI-PRO cutters

- 3 wing • 2-15/16" diameter
- 3/4" bore • Runs with a 1-11/16" diameter rub bearing (AM-90-027)

### PRO-LINE cutters

- 3 wing • 4" diameter
- 1-1/4" bore • Runs with a 2-3/4" diameter rub bearing (AP-90-044)

Standard sets cut 1/4" x 5/8" or 1/2" x 5/8" deep tongue and groove. Mini-Pro is not to be used on 1/2" spindle.

These 8 piece cutter sets are built to cut both 1-3/8" passage doors and 1-3/4" entry doors simply by changing the center cutters.

A 2 piece glass panel groover set is also available to run with these sets (see page 19).

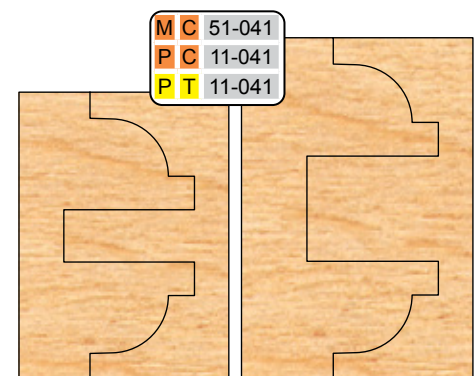
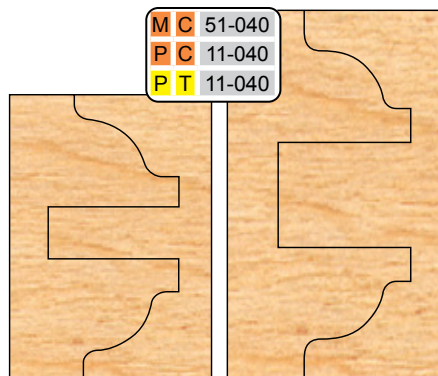
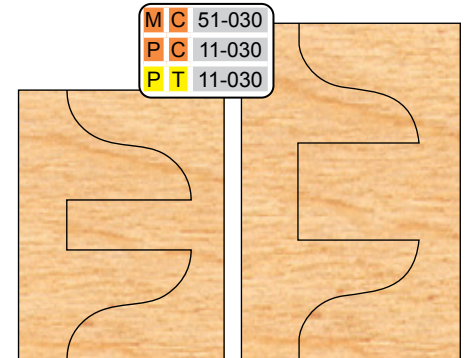
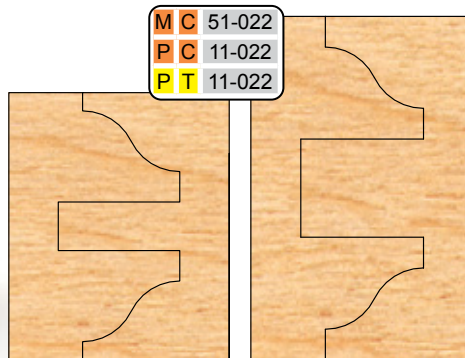
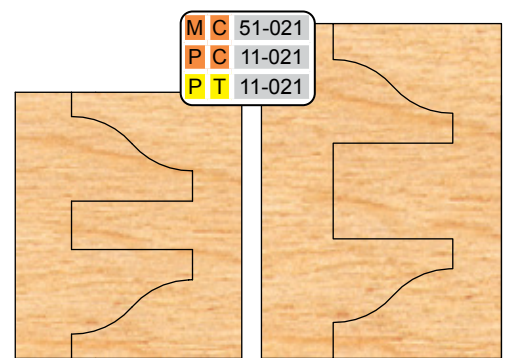
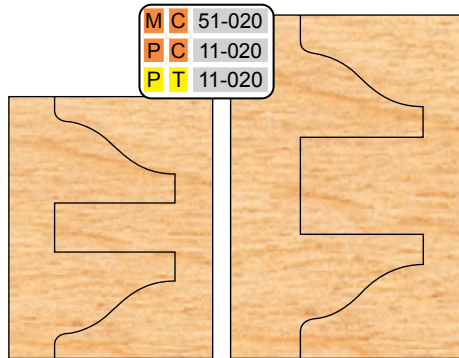
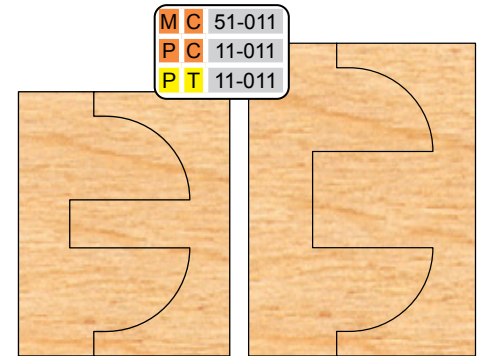
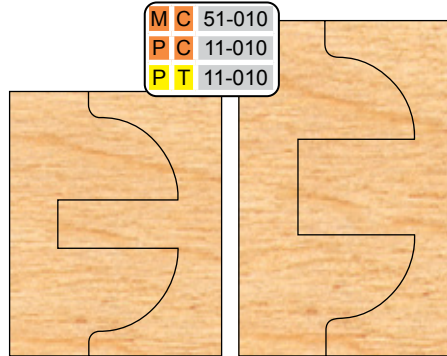

# DOUBLE SIDED COPE & PATTERN (8 Piece Cutter Sets)

PRODUCT ORDER CODE		M - MINI-PRO	(3/4" Bore)
M C	00-000	P - PRO-LINE	(1-1/4" Bore)
P C	00-000	C - Carbide Tip	(Orange)
P T	00-000	T - T-Alloy Tip	(Yellow)

Eased edges are available for an additional 20%.

See custom cutter ordering information on inside back cover. Same day quoting.

Standard sets cut 1/4" x 5/8" or 1/2" x 5/8" deep tongue and groove. Mini-Pro is not to be used on 1/2" spindle.

These 8 piece cutter sets are built to cut both 1-3/8" passage doors and 1-3/4" entry doors simply by changing the center cutters.

A 2 piece glass panel groover set is also available to run with these sets (see page 19).

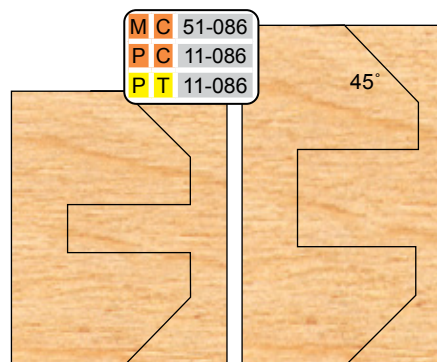
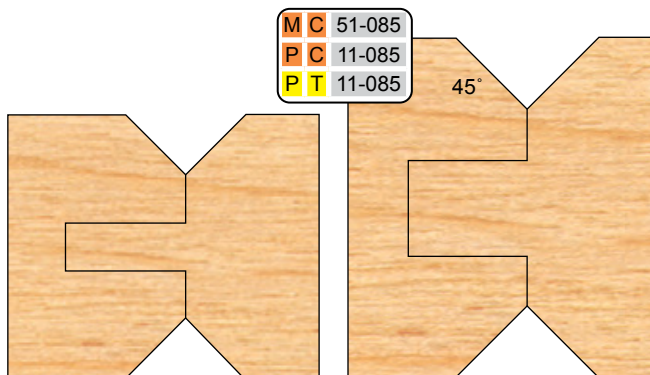
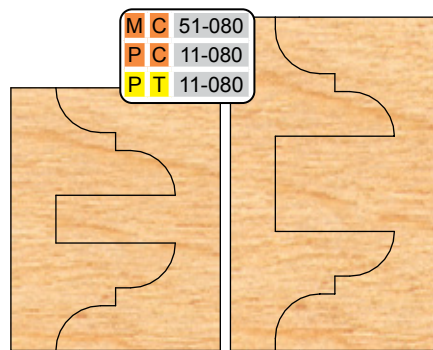
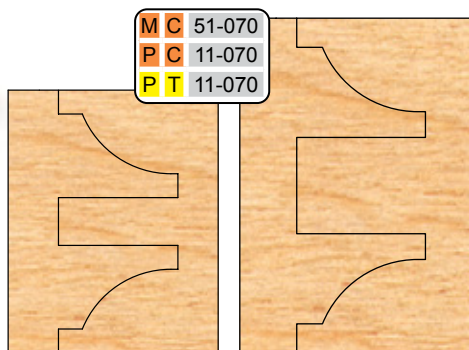
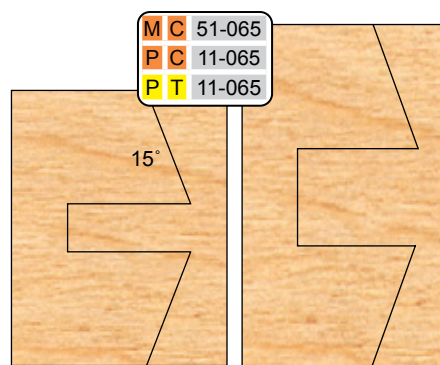
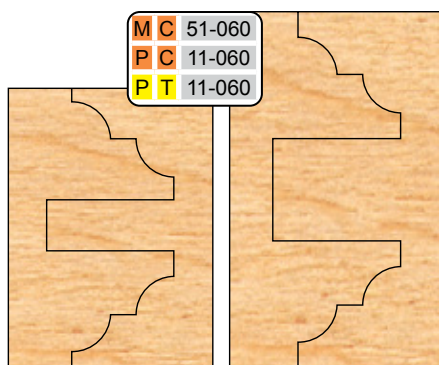
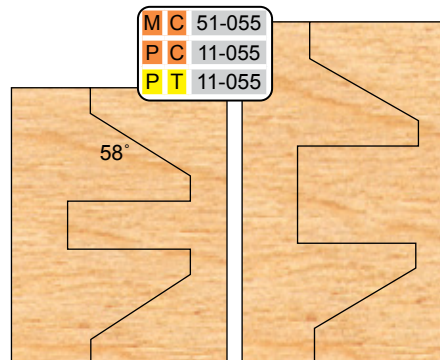
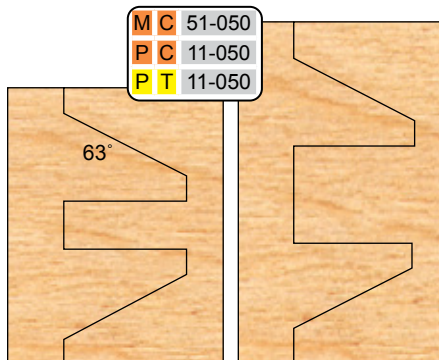

## DOUBLE SIDED COPE & PATTERN (8 Piece Cutter Sets)

Standard sets cut 1/4" x 5/8" or 1/2" x 5/8" deep tongue and groove. Mini-Pro is not to be used on 1/2" spindle.

These 8 piece cutter sets are built to cut both 1-3/8" passage doors and 1-3/4" entry doors simply by changing the center cutters.

Any of the below groover sets may be exchanged at no charge at the time of purchase.

### MINI-PRO cutters

- 3 wing • 2-15/16" diameter
- 3/4" bore • Runs with a 1-11/16" diameter rub bearing (AM-90-027)

### PRO-LINE cutters

- 3 wing • 4" diameter
- 1-1/4" bore • Runs with a 2-3/4" diameter rub bearing (AP-90-044)

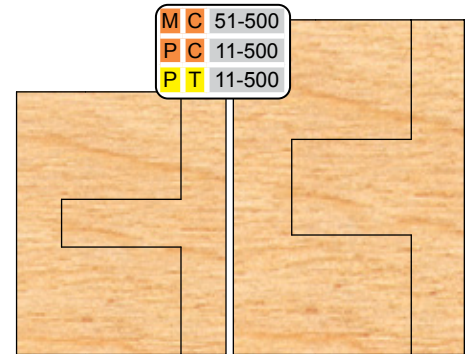
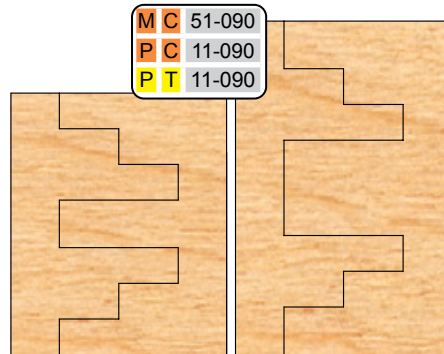

## DOUBLE SIDED COPE & PATTERN GROOVER OPTIONS (2 Piece Groover Sets)

5/8" Deep Center Groover Chart		
	• MINI PRO SET	• PRO-LINE SET
1/4" GROOVERS ONLY	MC-51-904	PC-11-904
		PT-11-904
3/8" GROOVERS ONLY	MC-51-903	PC-11-903
		PT-11-903
1/2" GROOVERS ONLY	MC-51-905	PC-11-905
		PT-11-905

1/2" Deep Center Groover Chart		
	• MINI PRO SET	• PRO-LINE SET
1/4" x 1/2"	MC-51-906	PC-11-906
		PT-11-906
3/8" x 1/2"	MC-51-907	PC-11-907
		PT-11-907
1/2" x 1/2"	MC-51-908	PC-11-908
		PT-11-908

## DOUBLE SIDED COPE & PATTERN GLASS PANEL OPTIONS (2 Piece Groover Sets)

These Glass Panel sets consist of 2" groovers to allow a total material height of 2-1/2" when run with the profile cutters from your Cope and Pattern set. Any of the Double Sided Cope and Pattern profiles can be made into dedicated Glass Panel sets and are shown on pages 20 and 21.

Profile shapes are for example only. Set consists of 2 groovers only.

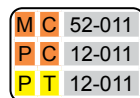

Runs with 010, 011, 022, 040, 041, 060 and 500.

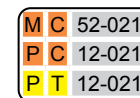
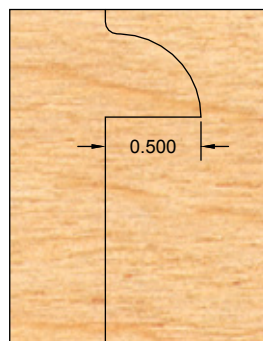

Runs with 020, 021, 030, 050, 070, 080, 090 and 500.

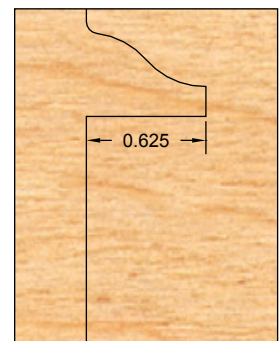

# GLASS PANEL (4 Piece Sets)

## MINI-PRO cutters

- 3 wing • 2-15/16" diameter
- 3/4" bore • Runs with a 1-11/16" diameter rub bearing (AM-90-027)

## PRO-LINE cutters

- 3 wing • 4" diameter
- 1-1/4" bore • Runs with a 2-3/4" diameter rub bearing (AP-90-044)

Freeborn Tool company now offers 4 piece Glass Panel Sets. Each set comes with 2 profile cutters and 2 glass panel goovers matched to the depth of the profile, either 1/2" or 5/8". In addition, for profiles 065-086 which have a different profile depth, you can choose between either the 1/2" or 5/8 deep glass panel cut.

Glass Panel sets are designed to cut up to 2-1/2" material, utilizing a 2" groovever, and the profile cutter. Runs CCW, material face down.

MC 51-010-GP  
PC 11-010-GP  
PT 11-010-GP

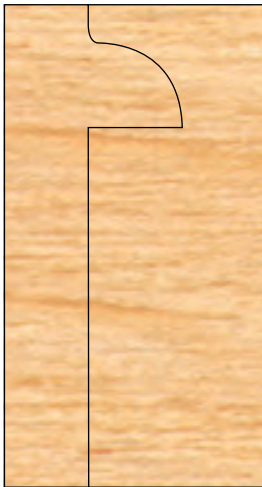

MC 51-011-GP  
PC 11-011-GP  
PT 11-011-GP

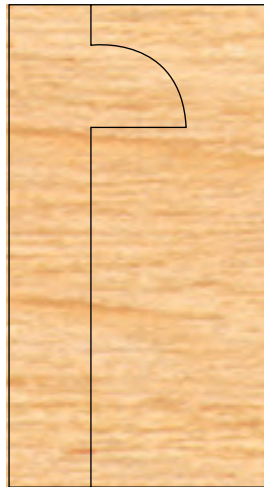

MC 51-020-GP  
PC 11-020-GP  
PT 11-020-GP

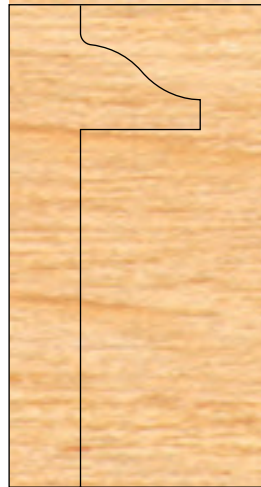

MC 51-021-GP  
PC 11-021-GP  
PT 11-021-GP

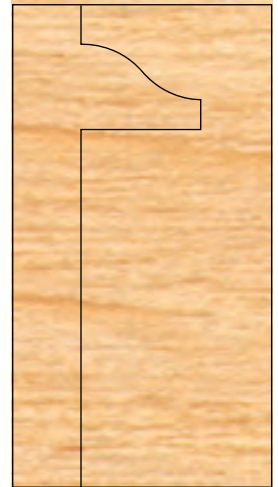

MC 51-022-GP  
PC 11-022-GP  
PT 11-022-GP

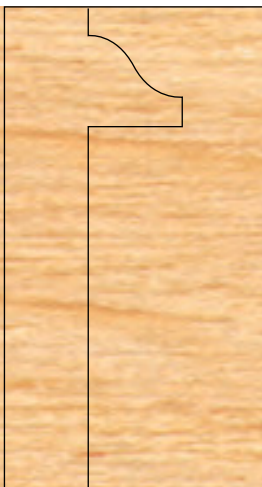

MC 51-030-GP  
PC 11-030-GP  
PT 11-030-GP

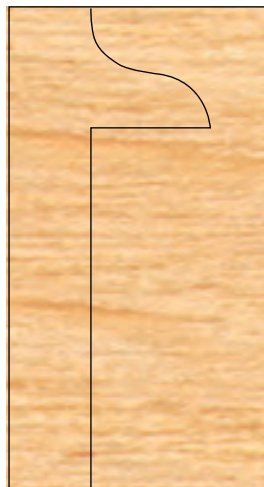

MC 51-040-GP  
PC 11-040-GP  
PT 11-040-GP

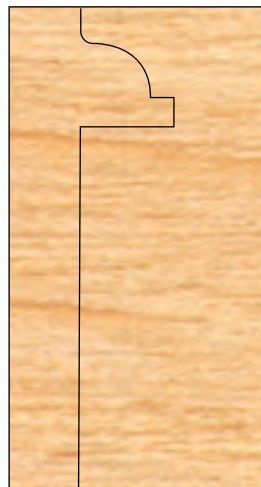

MC 51-041-GP  
PC 11-041-GP  
PT 11-041-GP

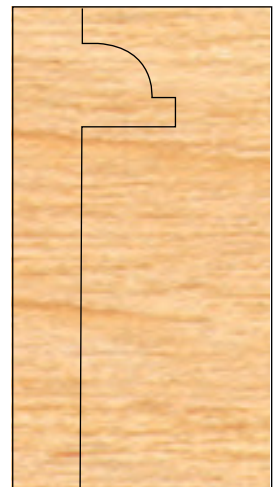

# GLASS PANEL (4 Piece Sets)

Glass Panel sets are designed to cut up to 2-1/2" material, utilizing a 2" groover, and the profile cutter

## MINI-PRO cutters

- 3 wing • 2-15/16" diameter
- 3/4" bore • Runs with a 1-11/16" diameter rub bearing (AM-90-027)

## PRO-LINE cutters

- 3 wing • 4" diameter
- 1-1/4" bore • Runs with a 2-3/4" diameter rub bearing (AP-90-044)

MC 51-050-GP  
PC 11-050-GP  
PT 11-050-GP

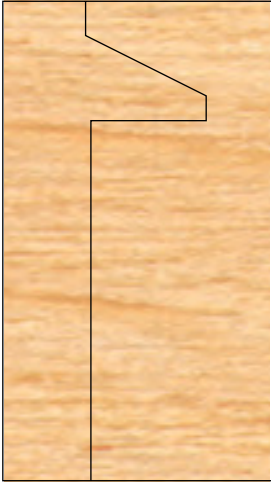

MC 51-055-GP  
PC 11-055-GP  
PT 11-055-GP

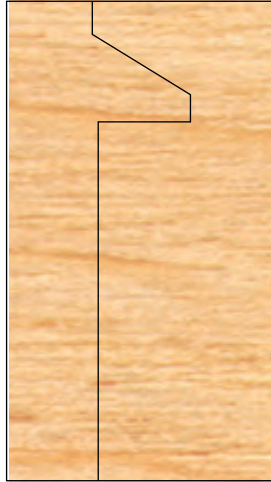

MC 51-060-GP  
PC 11-060-GP  
PT 11-060-GP

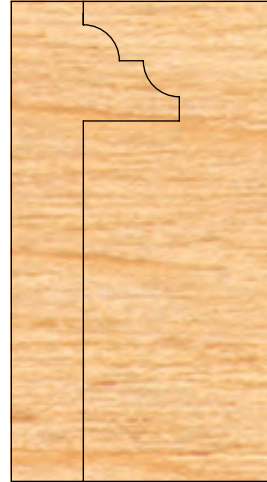

MC 51-065-GP  
PC 11-065-GP  
PT 11-065-GP

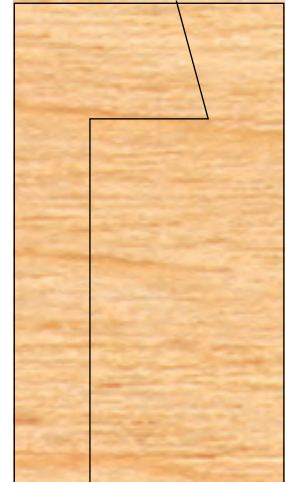

MC 51-070-GP  
PC 11-070-GP  
PT 11-070-GP

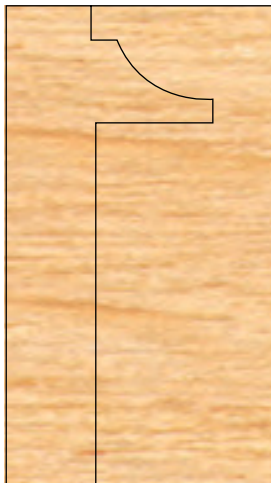

MC 51-080-GP  
PC 11-080-GP  
PT 11-080-GP

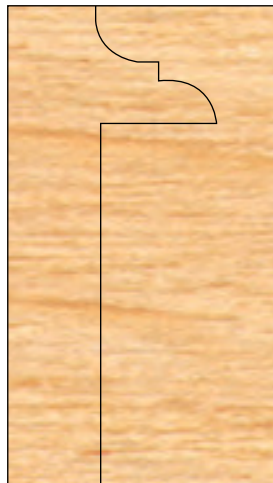

MC 51-086-GP  
PC 11-086-GP  
PT 11-086-GP

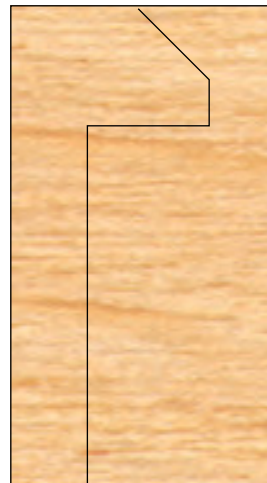

MC 51-090-GP  
PC 11-090-GP  
PT 11-090-GP

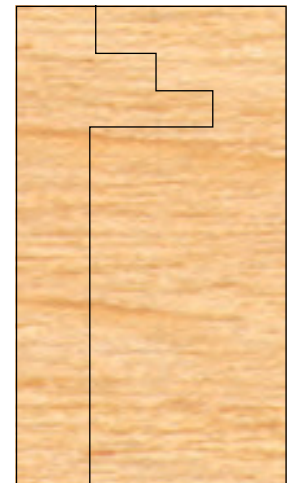

MC 51-500-GP  
PC 11-500-GP  
PT 11-500-GP

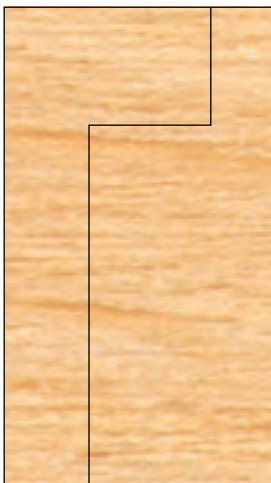

For profile 065 and 086 let us know at the time of order what depth you would like the glass panel cut to be: either 1/2" or 5/8" deep.

# RAISED PANEL SHAPER CUTTERS (3/4" MATERIAL)

## MINI-PRO cutters

- 3 wing • 4-1/2" diameter
- 3/4" bore • Runs with a 1-5/8" diameter rub bearing (AM-90-026)

## PRO-LINE cutters

- 3 wing • 6" diameter
- 1-1/4" bore • Runs with a 3" diameter rub bearing (AP-90-048)

Our raised panel cutters are manufactured with 15° SHEAR to produce optimum cuts both with and across the grain.

Counterclockwise rotation with wood fed face up.

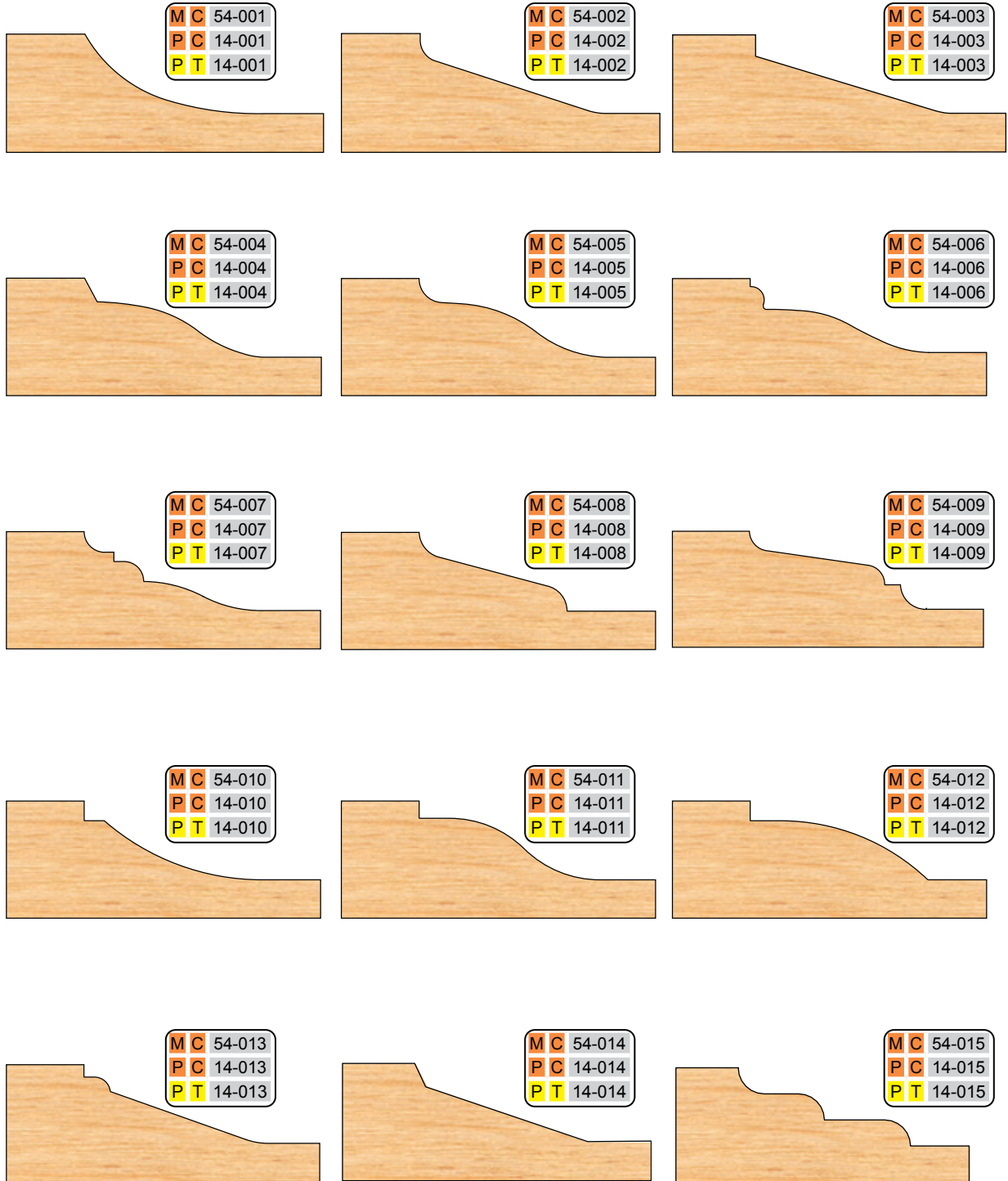

For opposite rotation, add 20% to the suggested list price.

## RAISED PANEL SHAPER CUTTERS (3/4" MATERIAL)

### MINI-PRO cutters

- 3 wing • 4-1/12" diameter
- 3/4" bore • Runs with a 1-5/8" diameter rub bearing (AM-90-026)

### PRO-LINE cutters

- 3 wing • 6" diameter
- 1-1/4" bore • Runs with a 3" diameter rub bearing (AP-90-048)

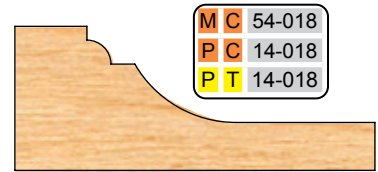
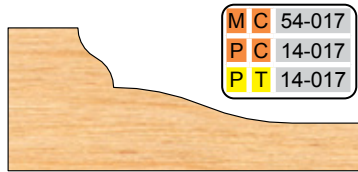
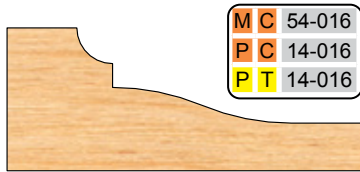

## RAISED PANEL SHAPER CUTTERS (5/8" MATERIAL)

Use with a back cutter to cut 3/4" material.

### MINI-PRO cutters

- 3 wing • 4-1/2" diameter
- 3/4" bore • Runs with a 1-5/8" diameter rub bearing (AM-90-026)

### PRO-LINE cutters

- 3 wing • 6" diameter
- 1-1/4" bore • Runs with a 3" diameter rub bearing (AP-90-048)

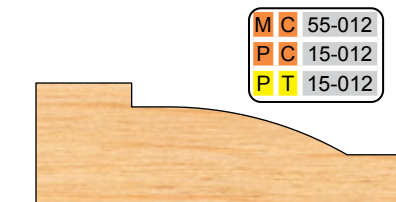
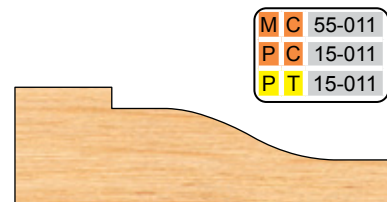
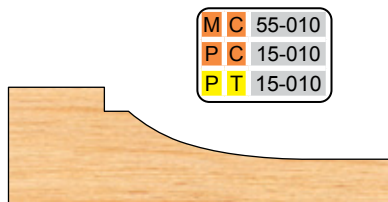
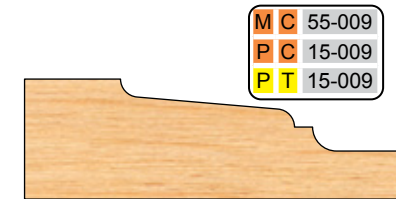
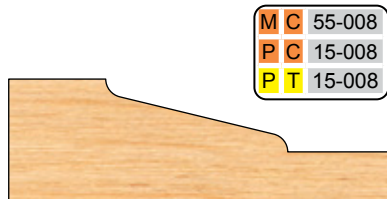
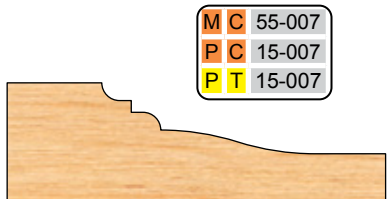
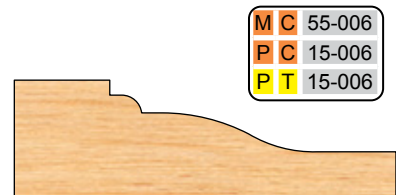
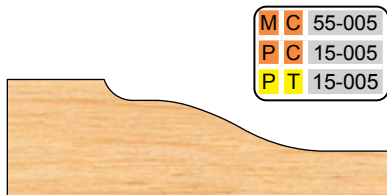
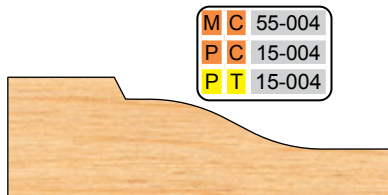
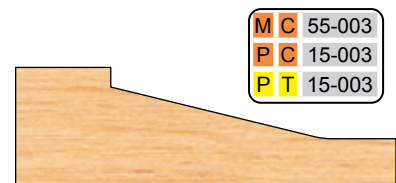
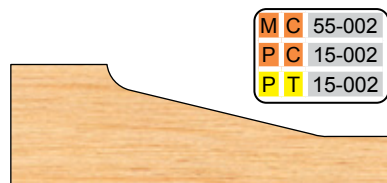
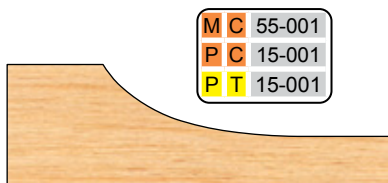

## RAISED PANEL SHAPER CUTTERS (5/8" MATERIAL)

Use with a back cutter to cut 3/4" material.

Our raised panel cutters are manufactured with 15° SHEAR to produce optimum cuts both with and across the grain.

Counterclockwise rotation with wood fed face up.

For *opposite rotation*, add 20% to the suggested list price.

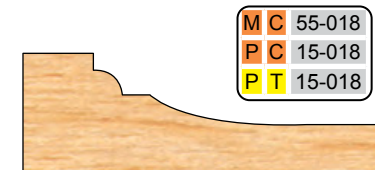
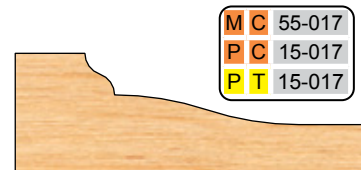
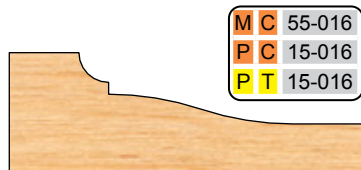
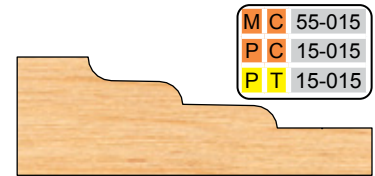
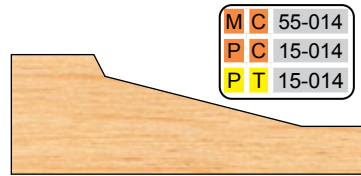
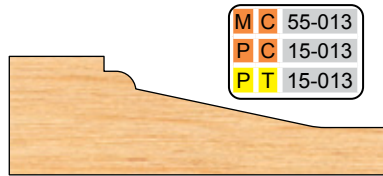

### MINI-PRO cutters

- 3 wing • 4-1/2" diameter
- 3/4" bore • Runs with a 1-5/8" diameter rub bearing (AM-90-026)

### PRO-LINE cutters

- 3 wing • 6" diameter
- 1-1/4" bore • Runs with a 3" diameter rub bearing (AP-90-048)

## BACK CUTTERS - RAISED PANEL (3/4" MATERIAL)

Use with a 55/15 series raised panel for 3/4" material.

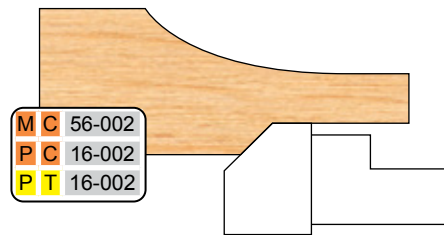
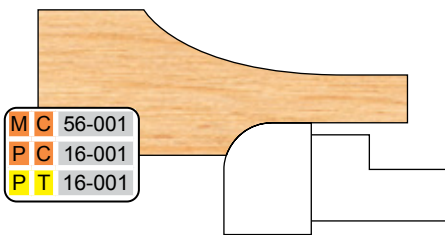

### MINI-PRO cutters

- 3 wing • 3-3/8" diameter
- 3/4" bore

### PRO-LINE cutters

- 4-3/4" diameter
- 1-1/4" bore

Does not include Raised Panel Cutter

## RAISED PANEL TONGUE TRIMMER

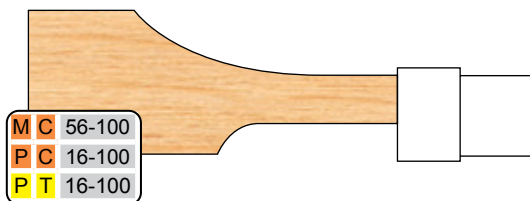

### MINI-PRO cutters

- 3 wing • 1-5/8" diameter
- 3/4" bore

### PRO-LINE cutters

- 3" diameter
- 1-1/4" bore

Does not include Raised Panel Cutter

## RAISED PANEL SHAPER CUTTERS (1/2" MATERIAL)

Manufactured with 15° SHEAR to produce optimum cuts both with and across the grain.

Counterclockwise rotation with wood fed face up.

These raised panel cutters cut a 1-3/8" reveal plus a 3/8" long tongue. Reduce production time by adding an opposite rotation cutter, and produce double sided raised panels in a single pass.

Opposite rotation cutters are made to order.

### PRO-LINE cutters

- 3 wing • 1-1/4" bore
- designed to run with a 3" diameter rub bearing (AP-90-048)
- Available in pro-line only

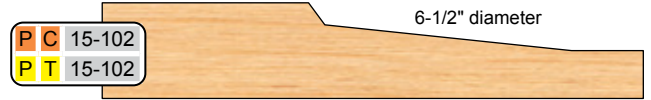

## RAISED PANEL SHAPER CUTTERS

### PRO-LINE cutters

- 3 wing • 1-1/4" bore
- designed to run with a 2-1/4" diameter rub bearing (AP-90-036)
- Available in pro-line only
- Diameters vary from 7-1/4" to 7-1/2"
- 2-1/2" overall depth of cut
- 1/2" Tenon

3/4" material



5/8" material



# DOOR EDGE DETAIL SHAPER CUTTERS

<b>MINI-PRO cutters</b> • 3 wing • 2-15/16" diameter • 3/4" bore • 1" wide tips	<b>PRO-LINE cutters</b> • 3 wing • 4" diameter • 1-1/4" bore • 1" wide tips
---	---

All of these wood samples are full scale as shown. Whether it is a 30° back bevel, fingerpull, 3/8" offset, or flush overlay door, we offer a wide selection to choose from.











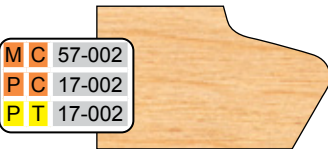
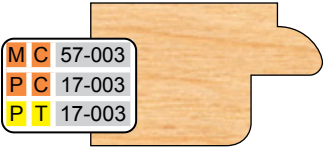

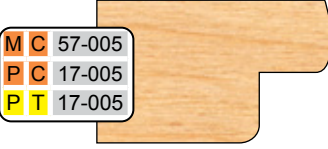
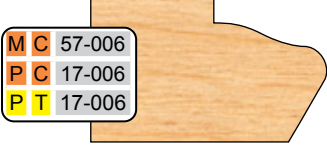
Counterclockwise rotation with wood fed face up.

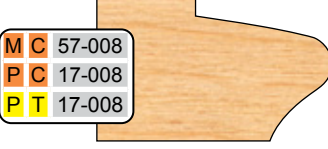
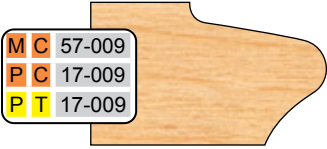
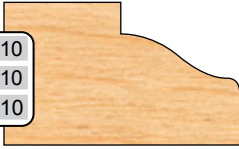
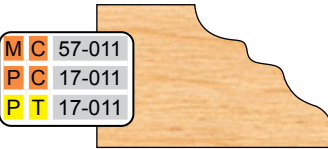
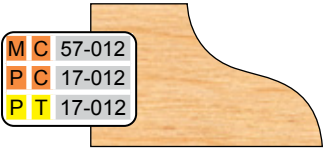
To order custom profiles, see our Custom Made Tooling page in the back of the catalog.

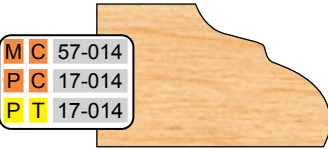
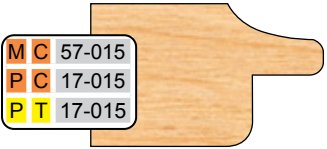

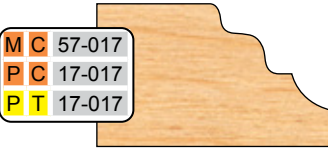
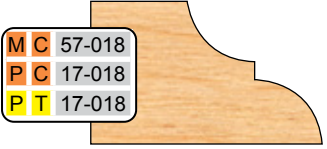
For opposite rotation, add 20% to the suggested list price.

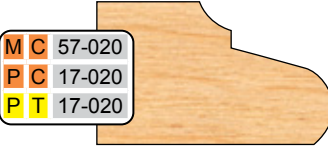
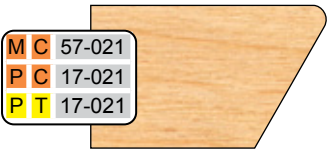
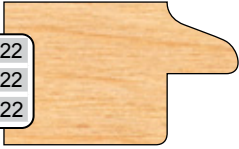
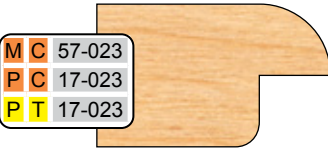
Wood samples shown actual size.

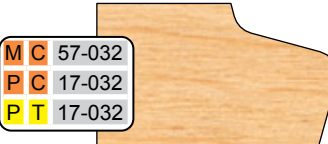
 MC 57-001 PC 17-001 PT 17-001	 MC 57-002 PC 17-002 PT 17-002	 MC 57-003 PC 17-003 PT 17-003
 MC 57-004 PC 17-004 PT 17-004	 MC 57-005 PC 17-005 PT 17-005	 MC 57-006 PC 17-006 PT 17-006
 MC 57-007 PC 17-007 PT 17-007	 MC 57-008 PC 17-008 PT 17-008	 MC 57-009 PC 17-009 PT 17-009
 MC 57-010 PC 17-010 PT 17-010	 MC 57-011 PC 17-011 PT 17-011	 MC 57-012 PC 17-012 PT 17-012
 MC 57-013 PC 17-013 PT 17-013	 MC 57-014 PC 17-014 PT 17-014	 MC 57-015 PC 17-015 PT 17-015
 MC 57-016 PC 17-016 PT 17-016	 MC 57-017 PC 17-017 PT 17-017	 MC 57-018 PC 17-018 PT 17-018
 MC 57-019 PC 17-019 PT 17-019	 MC 57-020 PC 17-020 PT 17-020	 MC 57-021 PC 17-021 PT 17-021
 MC 57-022 PC 17-022 PT 17-022	 MC 57-023 PC 17-023 PT 17-023	
 MC 57-024 PC 17-024 PT 17-024	 MC 57-032 PC 17-032 PT 17-032	

Similar to 002 profile but .100 backout

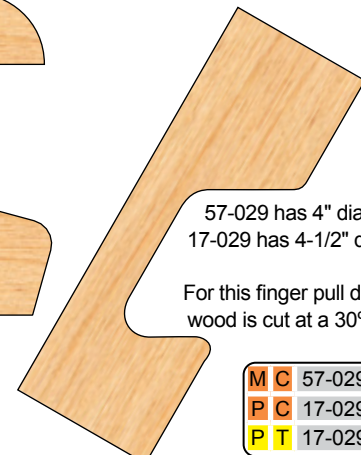

57-029 has 4" diameter  
 17-029 has 4-1/2" diameter

For this finger pull detail, the wood is cut at a 30° incline.

MC 57-029
PC 17-029
PT 17-029

## DOOR EDGE DETAIL BEVEL CUTTERS

### MINI-PRO cutters

- 3 wing
- 3/4" bore • 1" wide tips

### PRO-LINE cutters

- 3 wing
- 1-1/4" bore • 1" wide tips

For a different angle or a wider bevel cutter than those shown, ask our custom cutter department for a quote (See inside back cover).



30° Bevel

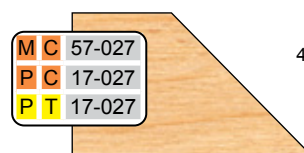
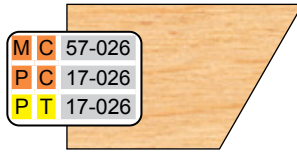

45 Bevel

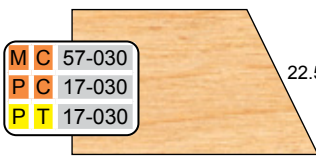
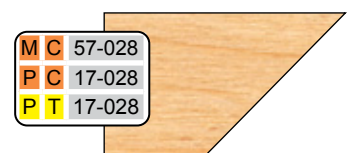

22.5° Bevel

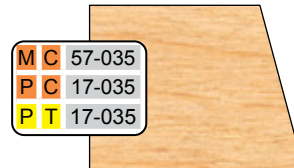
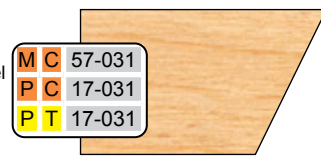

15 Bevel

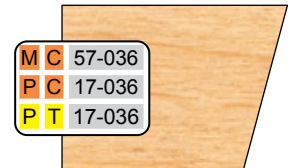

## DOOR EDGE DETAIL XL BEVEL CUTTERS

### PRO-LINE cutters

- 3 wing
- 1-1/4" bore • 1-3/4" wide tips

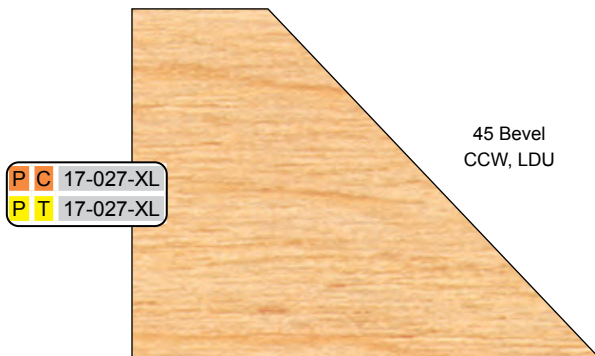

45 Bevel  
CCW, LDU

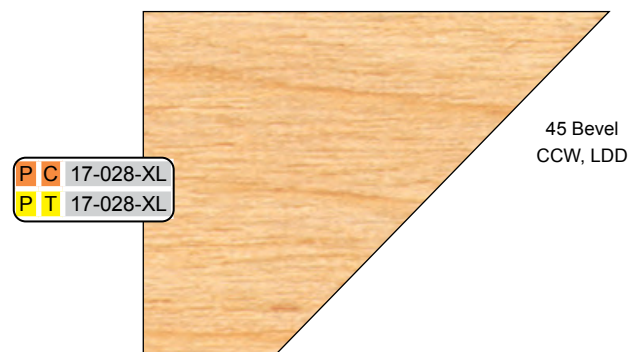

45 Bevel  
CCW, LDD

# DOOR EDGE DETAILS (32MM HINGE SYSTEM)

## MINI-PRO cutters

- 3 wing • 2-1/16" minor diameter
- 3/4" bore

## PRO-LINE cutters

- 3 wing • 3-1/16" minor diameter
- 1-1/4" bore

*Major diameter varies with depth of cut*

Part number is for top cutter only.

Manufactured with 15° SHEAR to produce optimum cuts both with and across grain.

Counterclockwise rotation with wood fed face up.

Any top cutter is designed to nest and run with any bottom cutter.



For opposite rotation, add 20% to the suggested list price.

To order custom profiles, see our Custom Made Tooling page in the back of the catalog. Same day quoting.

Wood samples shown actual size.

## Top Cutter Profiles 3/4" to 7/8" material

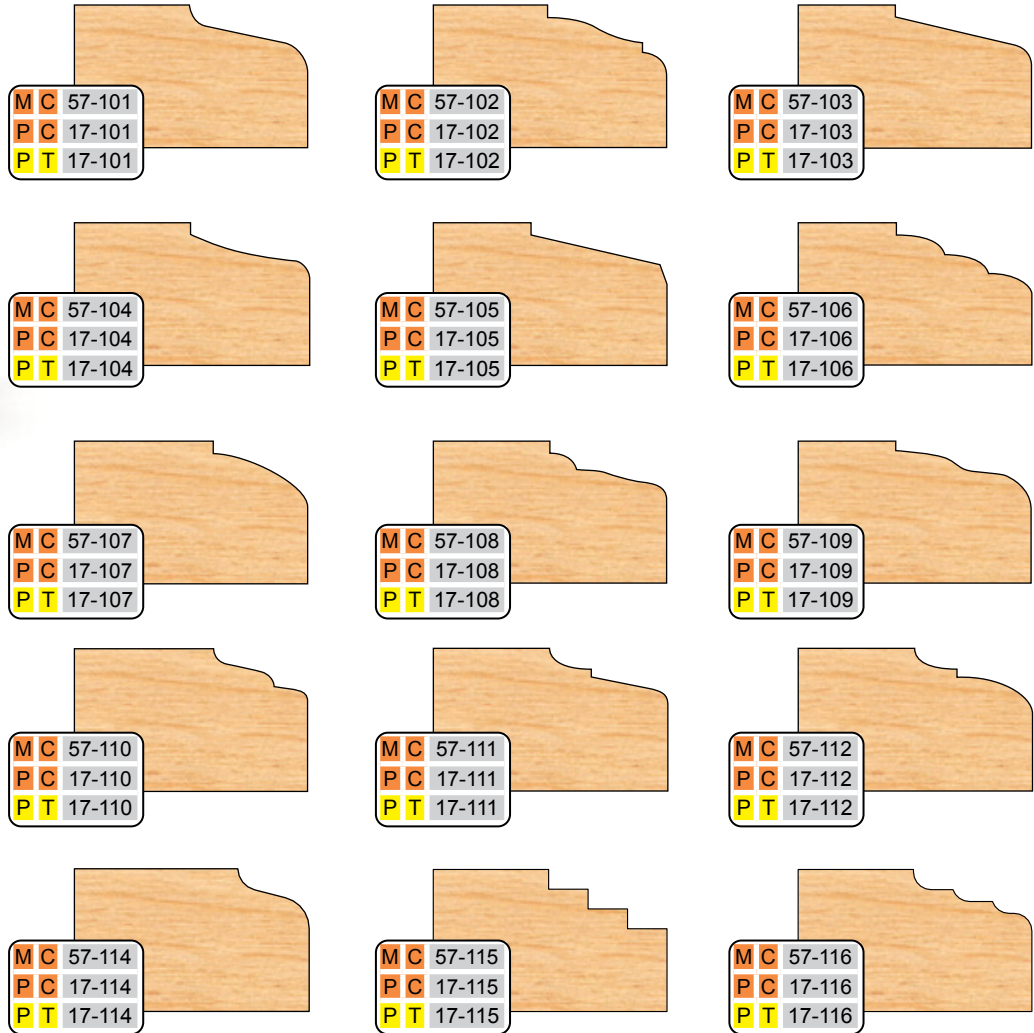

Bottom cutters for 32mm Hinge Systems are designed to nest and run with any top cutter listed.

Selection of bottom cutter should depend upon the distance of the bored hole for the hinge from the edge of the door.

Manufactured to the same specifications as all top cutters.

## Bottom Cutter Profiles

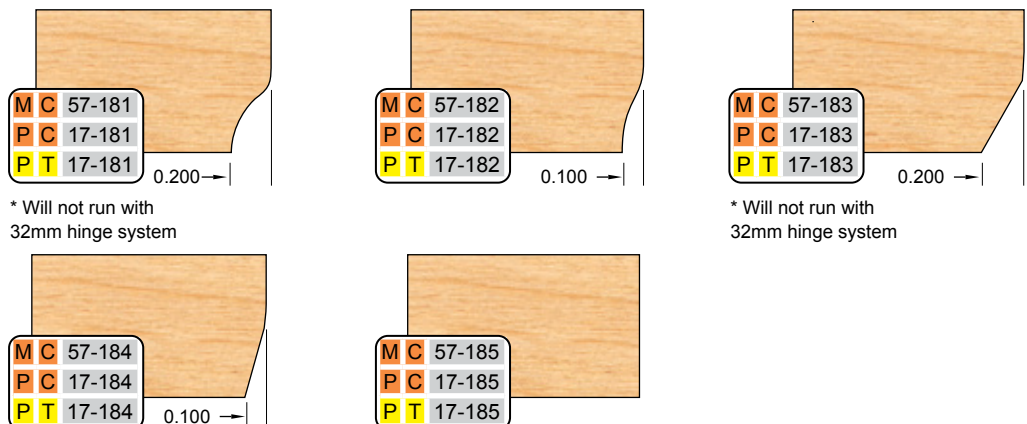

\* Will not run with 32mm hinge system

\* Will not run with 32mm hinge system

# DOOR EDGE DETAILS (32MM HINGE SYSTEM)

## PRODUCT ORDER CODE

M	C	00-000
P	C	00-000
P	T	00-000

M - MINI-PRO	(3/4" Bore)
P - PRO-LINE	(1-1/4" Bore)
C - Carbide Tip	(Orange)
T - T-Alloy Tip	(Yellow)

### Top Cutter Profiles 7/8" to 1" material

Part number is for top cutter only.

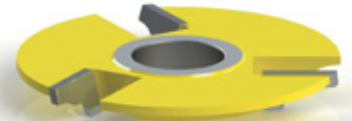
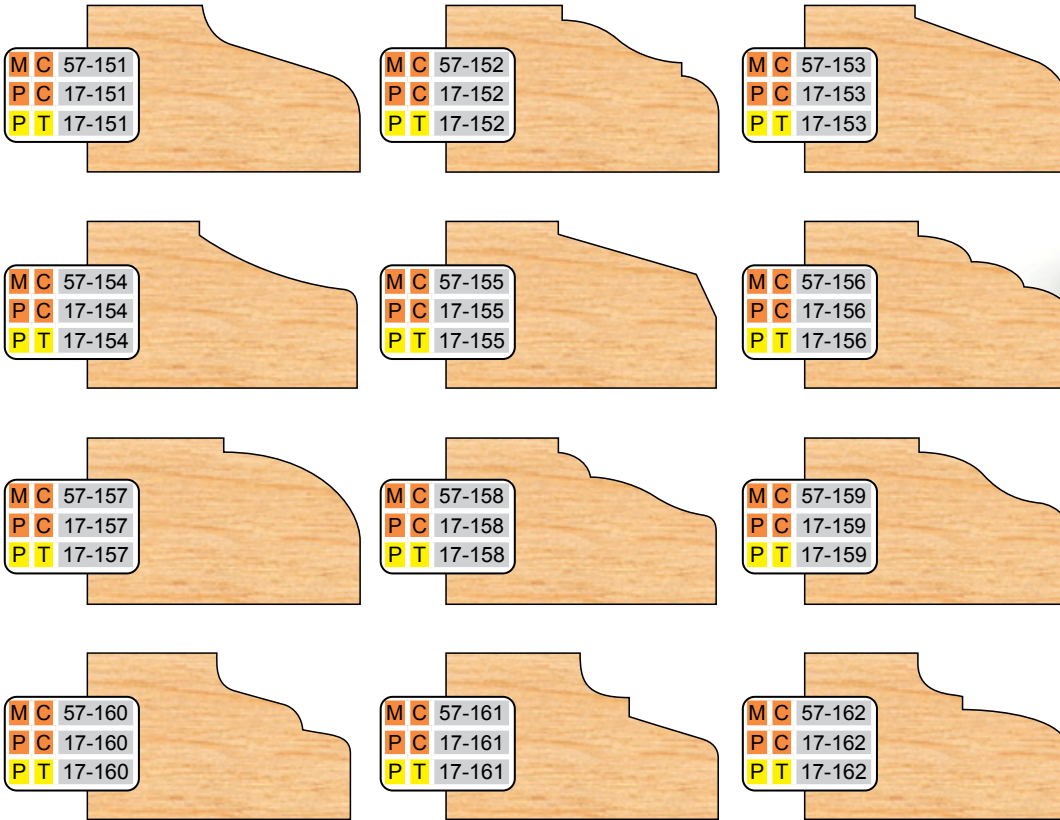

To order **custom profiles**, see our *Custom Made Tooling* page in the back of the catalog. Same day quoting.

Wood samples shown actual size.



## BEAD CUTTERS

### MINI-PRO cutters

- 3 wing
- 3/4" bore
- 2-15/16" diameter

### PRO-LINE cutters

- 3 wing
- 1-1/4" bore
- 4" diameter



M	C	57-040
P	C	17-040
P	T	17-040

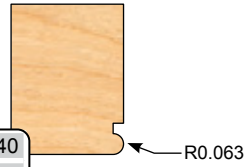

M	C	57-044
P	C	17-044
P	T	17-044

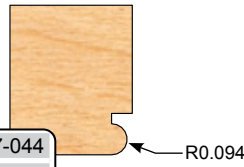

M	C	57-041
P	C	17-041
P	T	17-041

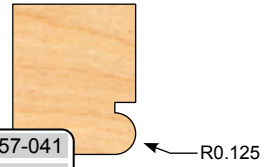

M	C	57-042
P	C	17-042
P	T	17-042

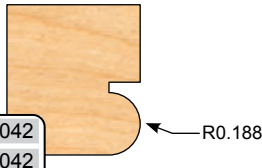

M	C	57-043
P	C	17-043
P	T	17-043

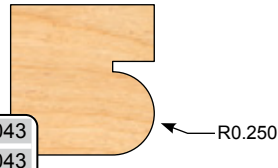

M	C	57-045
P	C	17-045
P	T	17-045

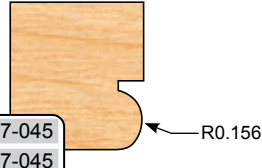

M	C	57-046
P	C	17-046
P	T	17-046

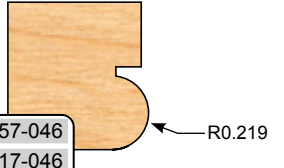

## HANDRAIL CUTTERS (2 PIECE SET)

### PRO-LINE cutters

- 3 wing
- 1-1/4" bore

2-1/4" wide x 2-3/8" tall  
5-1/4" diameter

P	C	17-050
P	T	17-050

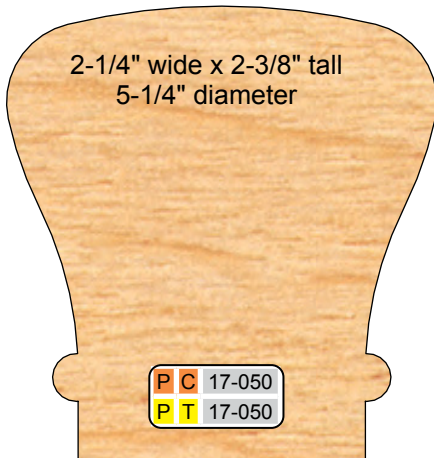

2-3/4" wide x 2-3/8" tall  
4" diameter

P	C	17-051
P	T	17-051

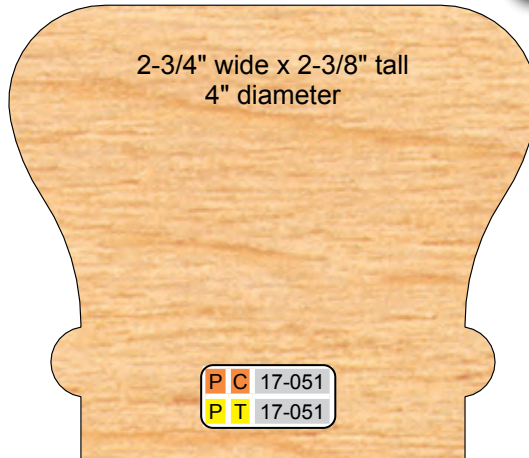

## WINDOW SILL CUTTERS

### MINI-PRO cutters

- 3 wing • 2-15/16" diameter
- 3/4" bore

### PRO-LINE cutters

- 3 wing • 4" diameter
- 1-1/4" bore

Edge Detail cutter  
for up to 7/8"  
material as shown

M	C	57-060
P	C	17-060
P	T	17-060

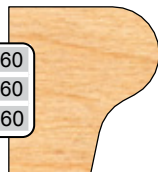

M	C	57-065
P	C	17-065
P	T	17-065

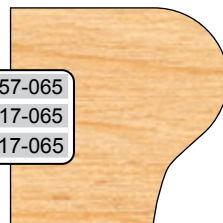

Edge Detail cutter  
for up to 1-1/8"  
material

## REVERSIBLE GLUE JOINT

Creates an incredibly strong joint by interlocking the glue surfaces.

### MINI-PRO cutters

- 3 wing • 2-15/16" diameter
- 3/4" bore • 1" wide tips
- Cuts from 1/2" to 7/8" material

### PRO-LINE cutters

- 3 wing • 2-15/16" diameter
- 1-1/4" bore • 2" wide tips
- Cuts from 1/2" to 1-7/8" material

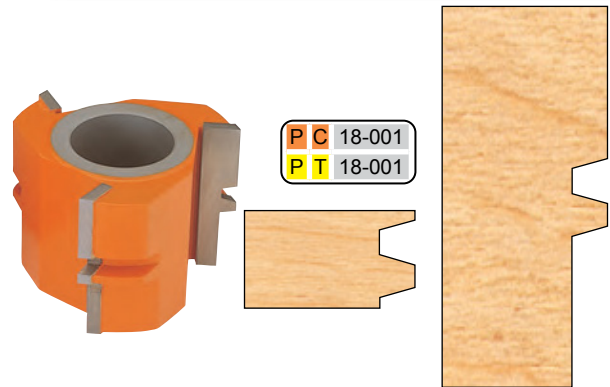
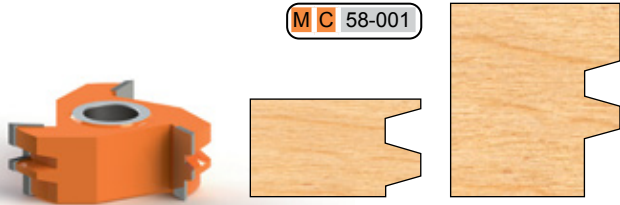

## WEDGE TONGUE & GROOVE

**10 Piece Set**  
(4 Cutters and 6 Spacers)

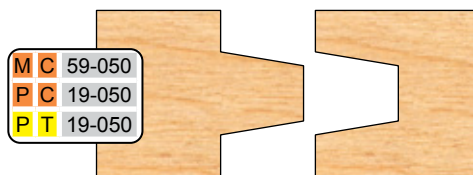

• 3 wing  
For up to 1" material

**2 Piece Set**

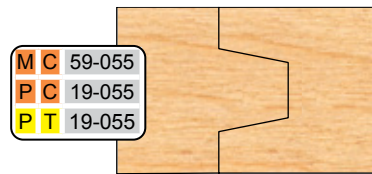

• 3 wing  
For up to 1" material

## EDGE BANDING

**3 Piece Set**  
1 piece solid cutters for female cut  
2 pieces split for male cut

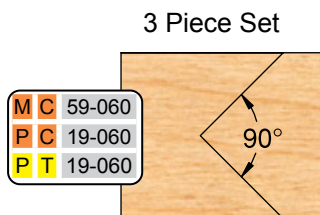

## V – GROOVE DETAIL CUTTER

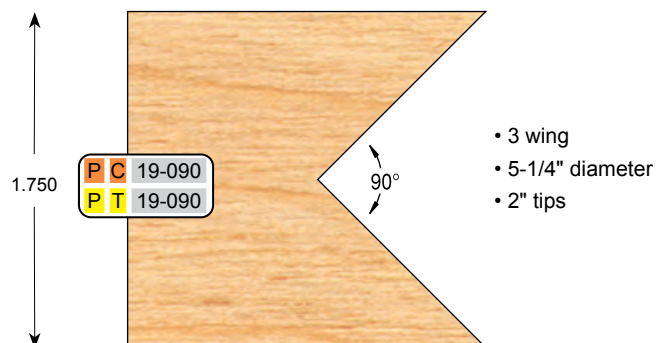

## V-PANELING SHAPER CUTTER SET

The V-Paneling set consists of 5 cutters and 1 spacer to perform these 4 functions.

Counterclockwise rotation with wood fed face down.

These sets do not share a common minor diameter.

M	C	59-010
P	C	19-010
P	T	19-010

3/4" to 1" material

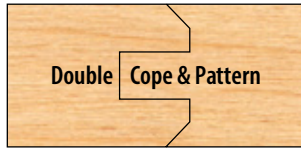
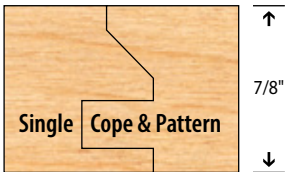
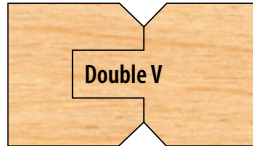
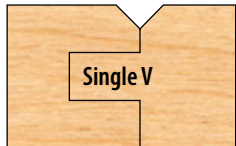

### MINI-PRO cutters

- 3 wing • 2-15/16" diameter
- 3/4" bore • designed to run with 2-3/16" diameter rub bearing

### PRO-LINE cutters

- 3 wing • 4" diameter
- 1-1/4" bore • designed to run with 3-1/4" diameter rub bearing

To order **custom profiles**, see our Custom Made Tooling page in the back of the catalog. Same day quoting. Wood samples shown actual size.

See stacking instructions on page 42.

### Optional Rub-Spacers & Groovers for Cope Side

NEW	MINI-PRO SET		PRO-LINE SET	
	RUB SPACER	GROOVER	RUB SPACER	GROOVER
SINGLE-V	AM-50-809		AP-10-809	PC-19-011 PT-19-011
DOUBLE-V	AM-50-809		AP-10-809	PC-19-011 PT-19-011
DOUBLE COPE & PATTERN	AM-50-801	MC-59-012	AP-10-801	PC-19-012 PT-19-012
SINGLE COPE & PATTERN	AM-50-801	MC-59-012	AP-10-801	PC-19-012 PT-19-012

## 7-PC. FLOORING SET

The flooring set consists of 6 cutters and 1 spacer to perform these 5 functions.

Cut provides a loose fit (.030) for wood expansion. Set up instructions included.

Counterclockwise rotation with wood fed face down.

See stacking instructions on page 42.

3/4" to 1" material

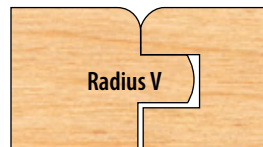
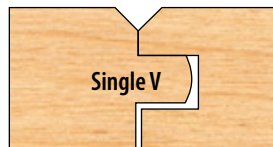

M	C	59-020
P	C	19-020
P	T	19-020

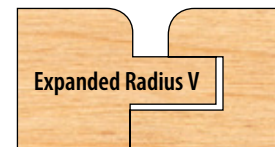
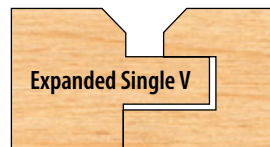

### MINI-PRO cutters

- 3 wing • 2-15/16" diameter
- 3/4" bore

### PRO-LINE cutters

- 3 wing • 4" diameter
- 1-1/4" bore

## 5-PC. FLOORING SET WITH NAIL SLOT

### MINI-PRO cutters

- 3 wing • 2-15/16" diameter
- 3/4" bore

### PRO-LINE cutters

- 3 wing • 4" diameter
- 1-1/4" bore

This set includes 5 cutters to perform the cut as shown.

Counterclockwise rotation with wood fed face down.

Up to 1" material.

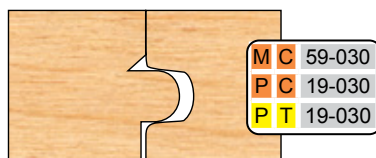

## 8-PC. FLOORING / V-PANEL SET

### MINI-PRO cutters

- 3 wing • 2-15/16" diameter
- 3/4" bore

### PRO-LINE cutters

- 3 wing • 4" diameter
- 1-1/4" bore

This set includes 8 cutters to perform the two cuts as shown. Runs CCW, face down.

Cut provides a 0.010" loose fit to allow for wood expansion.

1/2" material

M	C	59-040
P	C	19-040
P	T	19-040

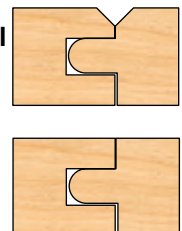

## V PANEL SET FOR 2" MATERIAL (5 PIECE SET)

**PRODUCT ORDER CODE** M - MINI-PRO (3/4" Bore)

**M C** 00-000

P - PRO-LINE (1-1/4" Bore)

**P C** 00-000

C - Carbide Tip (Orange)

**P T** 00-000

T - T-Alloy Tip (Yellow)

Runs CCW, material face down.

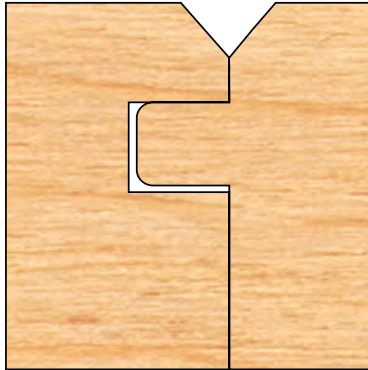

**P C** 19-070  
**P T** 19-070

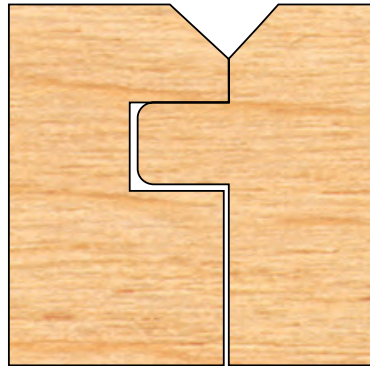

0.030 GAP  
for P-19-070 exchange  
for P-19-075 at time of  
purchase

The P-19-075 Groover may be exchanged  
at time of purchase for no charge

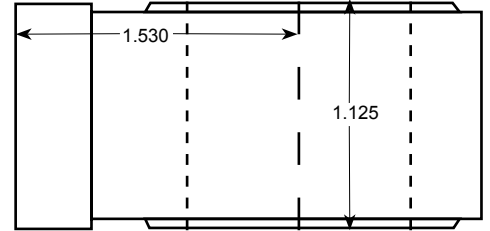

**P C** 19-075  
**P T** 19-075

## QUARTER COVE CONVEX CUTTERS

### MINI-PRO cutters

- 3 wing • 2-15/16" diameter
- 3/4" bore

### PRO-LINE cutters

- 3 wing • 4" diameter
- 1-1/4" bore

PART #			RADIUS
MC-60-002	PC-20-002	PT-20-002	1/8"
MC-60-004	PC-20-004	PT-20-004	1/4"
MC-60-006	PC-20-006	PT-20-006	3/8"
MC-60-008	PC-20-008	PT-20-008	1/2"
MC-60-012	PC-20-012	PT-20-012	3/4"
	PC-20-016	PT-20-016	1"



## REVERSIBLE PATTERN DETAIL

### MINI-PRO cutters

- 3 wing • 2-15/16" diameter
- 3/4" bore • 1" wide tips

### PRO-LINE cutters

- 3 wing • 4" diameter
- 1-1/4" bore • 1" wide tips

Counterclockwise rotation with wood fed face up.

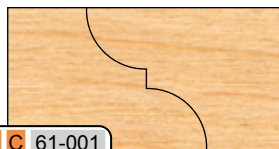

**M C** 61-001  
**P C** 21-001  
**P T** 21-001

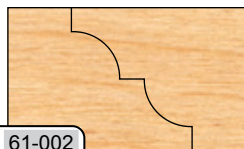

**M C** 61-002  
**P C** 21-002  
**P T** 21-002

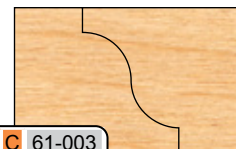

**M C** 61-003  
**P C** 21-003  
**P T** 21-003

After machining two  
pieces of wood, one  
piece may be inverted  
and plugged into its mate,  
forming a matched joint.



## STRAIGHT TOP GROOVERS

### MINI-PRO cutters

- 3 wing • 2-15/16" diameter
- 3/4" bore • designed for use with 2-15/16" diameter rubber bearing for flush trim application

### PRO-LINE cutters

- 3 wing • 4" diameter
- 1-1/4" bore • designed for use with 4" diameter rubber bearing for flush trim application

PART #			WIDTH
MC-62-002	PC-22-002	PT-22-002	1/8"
MC-62-003	PC-22-003	PT-22-003	3/16"
MC-62-004	PC-22-004	PT-22-004	1/4"
MC-62-005	PC-22-005	PT-22-005	5/16"
MC-62-006	PC-22-006	PT-22-006	3/8"
MC-62-007	PC-22-007	PT-22-007	7/16"
MC-62-008	PC-22-008	PT-22-008	1/2"
MC-62-010	PC-22-010	PT-22-010	5/8"
MC-62-012	PC-22-012	PT-22-012	3/4"
MC-62-014	PC-22-014	PT-22-014	7/8"
MC-62-016	PC-22-016	PT-22-016	1"
MC-62-020	PC-22-020	PT-22-020	1-1/4"
MC-62-024	PC-22-024	PT-22-024	1-1/2"
MC-62-028	PC-22-028	PT-22-028	1-3/4"
MC-62-032	PC-22-032	PT-22-032	2"

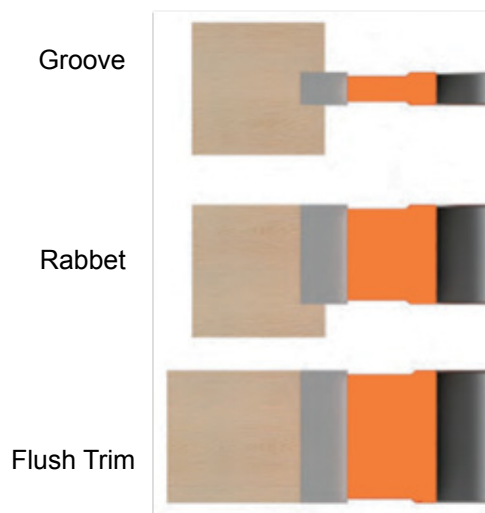

Straight Top Groovers are ideal for cutting grooves, rabbets, and for flush trimming.



## STRAIGHT TOP GROOVERS

PART #	DIAMETER	WINGS	KERF
GC-0406-.250	4"	6	1/4"
GC-0406-.375	4"	6	3/8"
GC-0406-.500	4"	6	1/2"
GC-0406-.750	4"	6	3/4"
GC-0608-.250	6"	8	1/4"
GC-0608-.375	6"	8	3/8"
GC-0608-.500	6"	8	1/2"
GC-0608-.750	6"	8	3/4"
GC-0812-.250	8"	12	1/4"
GC-0812-.375	8"	12	3/8"
GC-0812-.500	8"	12	1/2"
GC-0812-.750	8"	12	3/4"

### PRO-LINE cutters

- 6-12 wing
- 1-1/4" bore only
- 4-8" diameter per chart



## HALF ROUND CONVEX SHAPER CUTTERS

PART #			WIDTH	RADIUS
MC-63-002	PC-23-002	PT-23-002	1/4"	1/8"
MC-63-003	PC-23-003	PT-23-003	3/8"	3/16"
MC-63-004	PC-23-004	PT-23-004	1/2"	1/4"
MC-63-006	PC-23-006	PT-23-006	3/4"	3/8"
MC-63-008	PC-23-008	PT-23-008	1"	1/2"

### MINI-PRO cutters

- 3 wing • 2-15/16" diameter
- 3/4" bore

### PRO-LINE cutters

- 3 wing • 4" diameter
- 1-1/4" bore

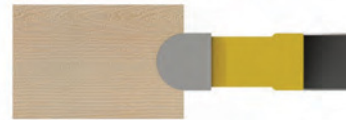

Flute



## HALF ROUND CONCAVE SHAPER CUTTERS

PART #			WIDTH	RADIUS
MC-64-002	PC-24-002	PT-24-002	1/4"	1/8"
MC-64-003	PC-24-003	PT-24-003	3/8"	3/16"
MC-64-004	PC-24-004	PT-24-004	1/2"	1/4"
MC-64-006	PC-24-006	PT-24-006	3/4"	3/8"
MC-64-008	PC-24-008	PT-24-008	1"	1/2"
MC-64-009	PC-24-009	PT-24-009	1-1/8"	9/16"
MC-64-010	PC-24-010	PT-24-010	1-1/4"	5/8"
	PC-24-012	PT-24-012	1-1/2"	3/4"

### MINI-PRO cutters

- 3 wing • 2-15/16" diameter
- 3/4" bore

### PRO-LINE cutters

- 3 wing • 4" diameter
- 1-1/4" bore



Bullnose

All Concave Cutters have .030" flare for easy bull nosing.



## MATCHED DROP LEAF

### MINI-PRO cutters

- 3 wing • 2-15/16" diameter
- 3/4" bore

### PRO-LINE cutters

- 3 wing • 4" diameter
- 1-1/4" bore

Counterclockwise rotation with wood face down. When running counterclockwise, cove cut is made by lowering shaper spindle to cut with the top half of the cutter. Bead cut is made by raising shaper spindle to cut with the bottom half of the cutter.

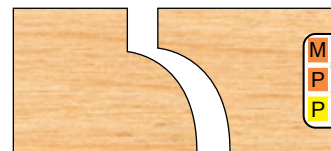

M	C	66-001
P	C	26-001
P	T	26-001

## WINDOW SASH CUTTER SET (4 PIECE CUTTER SET)

### MINI-PRO cutters

- 3 wing
- 3/4" bore

### PRO-LINE cutters

- 3 wing
- 1-1/4" bore

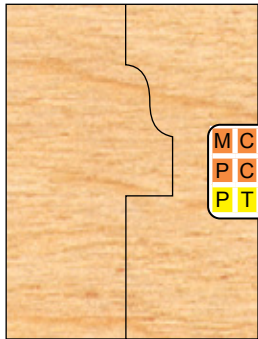

M	C	67-010
P	C	27-010
P	T	27-010

These window sash profiles are common in many older homes. They are made to cut stock up to 1-3/4".

Counterclockwise rotation with wood fed face down.

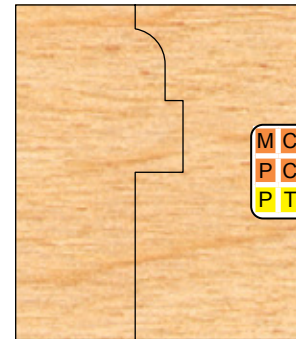

M	C	67-020
P	C	27-020
P	T	27-020

## WINDOW SASH CUTTER SET FOR MORTISE AND TENON (5 PIECE SET)

### PRO-LINE cutters

- 3 wing
- 1-1/4" bore only

This Window set is designed to allow a variable tenon length of up to 2-1/2" (4 Cutters, 1 Spacer per set)

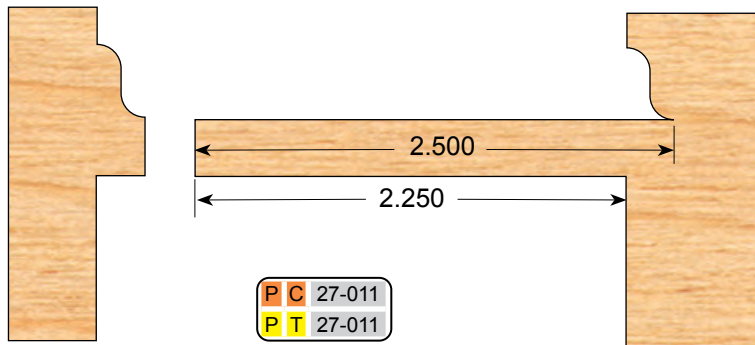
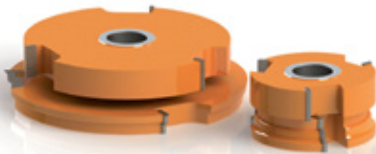

P	C	27-011
P	T	27-011

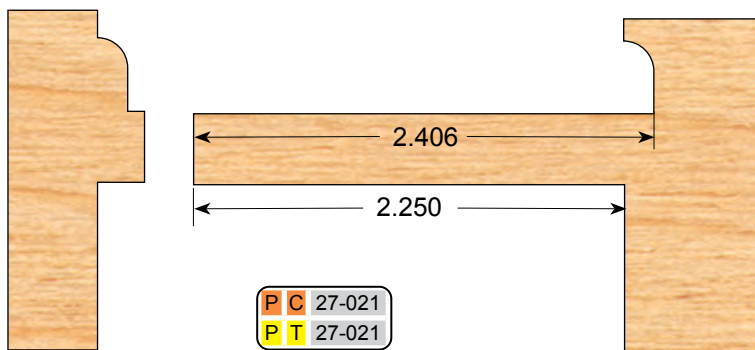

P	C	27-021
P	T	27-021

## ONE PIECE DOUBLE TONGUE & GROOVE LOCK MITRE CUTTER



Counterclockwise rotation only. Mini-Pro is made to run only on 3/4" spindle.

Part B is run flat in horizontal position on shaper table.

Part A is run in a vertical position against the shaper fence (see diagram). See page 28.

1/2" material

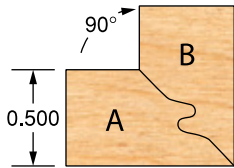

M C	68-030
P C	28-030
P T	28-030

3/4" to 1" material

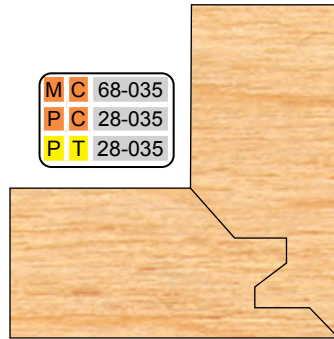

M C	68-035
P C	28-035
P T	28-035

3/4" to 1-1/2" material

**PRO-LINE cutters**

- 1-1/4" bore • 6" diameter
- 3 wing • 1-3/4" wide tips

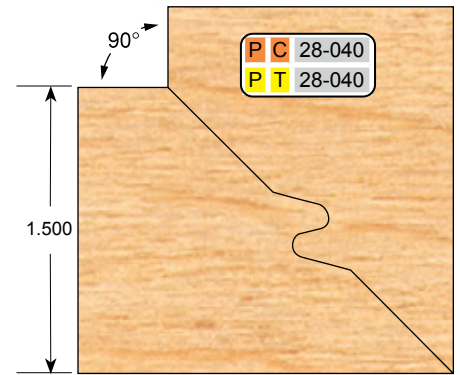

P C	28-040
P T	28-040

3/4" to 1" material

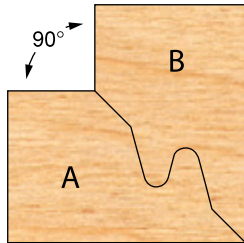

M C	68-001
P C	28-001
P T	28-001

## TWO PIECE DOUBLE TONGUE & GROOVE LOCK MITRE SETS

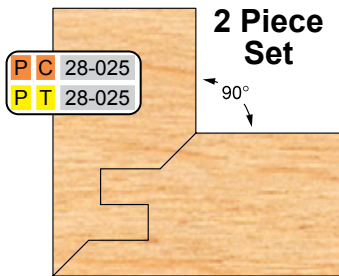

2 Piece Set

P C	28-025
P T	28-025

3/4" - 1" material

**PRO-LINE cutters**

- 3 wing
- 1-1/4" bore
- 5.19" diameter
- 1-1/4" wide tips

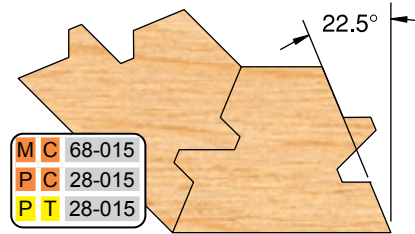

M C	68-015
P C	28-015
P T	28-015

3/4" material

**MINI-PRO cutters**

- 3 wing • 3/4" bore
- 2-15/16" diameter
- 1" wide tips

**PRO-LINE cutters**

- 3 wing • 4" diameter
- 1-1/4" bore
- 1" wide tips

## SINGLE TONGUE & GROOVE LOCK MITRE CUTTER (3 PIECE CUTTER SET)

Counterclockwise rotation only. Mini-Pro is made to run only on 3/4" spindle.

Material to 1-1/8".

Part A and B are both run flat in horizontal position on shaper table. Part B is run again on table saw to cut groove (see diagram).

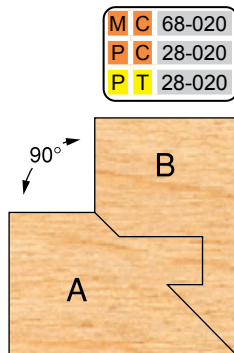

M C	68-020
P C	28-020
P T	28-020

**MINI-PRO cutters**

- 3 wing • 4-5/16" diameter
- 3/4" bore • Use on 3/4" Spindles only

**PRO-LINE cutters**

- 3 wing • 5-3/8" diameter
- 1-1/4" bore



## DRAWER LOCK CUTTER

Run drawer front face up in horizontal position over the top of the cutter. Drawer sides are run on end in a vertical position against the shaper fence.

Counterclockwise rotation only.

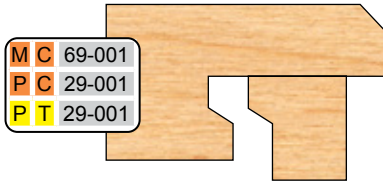

3/4" material

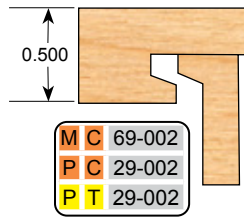

1/2" material

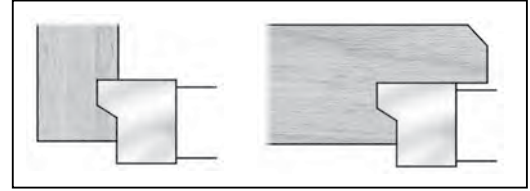

### MINI-PRO cutters

- 3 wing • 2-5/16" diameter
- 3/4" bore

### PRO-LINE cutters

- 3 wing • 5" diameter
- 1-1/4" bore

## 1-PIECE DOUBLE EASING CUTTERS

NUMBER			WIDTH	RADIUS
MC-71-006	PC-31-006	PT-31-006	3/8"	1/8"
MC-71-008	PC-31-008	PT-31-008	1/2"	1/8"
MC-71-012	PC-31-012	PT-31-012	3/4"	1/8"
MC-71-016	PC-31-016	PT-31-016	1"	1/8"
MC-71-020	PC-31-020	PT-31-020	1-1/4"	1/8"
MC-71-024	PC-31-024	PT-31-024	1-1/2"	1/8"

### MINI-PRO cutters

- 3 wing • 2-15/16" diameter
- 3/4" bore

### PRO-LINE cutters

- 3 wing • 4" diameter
- 1-1/4" bore

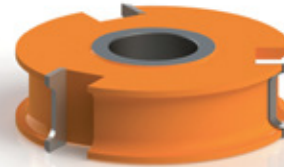

Custom rub bearings available for these cutters.

## CORNER ROUNDING SHAPER CUTTERS

Larger PRO-LINE Cutters exceed the standard 4" diameter (see chart).

Counterclockwise rotation with wood fed face down.

R = CCW, wood face up



### MINI-PRO cutters

- 3 wing • 2-15/16" diameter
- 3/4" bore

### PRO-LINE cutters

- 3 wing • 4" diameter or see below
- 1-1/4" bore

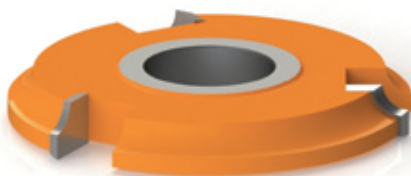

NUMBER			(R=Opposite Rotation)	RADIUS	3/4" Bore DIAMETER	1-1/4" Bore DIAMETER
MC-65-002	PC-25-002	PT-25-002		1/8"	2-15/16"	4"
MC-65-002R	PC-25-002R	PT-25-002R		1/8"	2-15/16"	4"
MC-65-003	PC-25-003	PT-25-003		3/16"	2-15/16"	4"
MC-65-004	PC-25-004	PT-25-004		1/4"	2-15/16"	4"
MC-65-004R	PC-25-004R	PT-25-004R		1/4"	2-15/16"	4"
MC-65-005	PC-25-005	PT-25-005		5/16"	2-15/16"	4"
MC-65-006	PC-25-006	PT-25-006		3/8"	2-15/16"	4"
MC-65-006R	PC-25-006R	PT-25-006R		3/8"	2-15/16"	4"
MC-65-008	PC-25-008	PT-25-008		1/2"	2-15/16"	4"
MC-65-008R	PC-25-008R	PT-25-008R		1/2"	2-15/16"	4"
MC-65-010	PC-25-010	PT-25-010		5/8"	2-15/16"	4"
MC-65-012	PC-25-012	PT-25-012		3/4"	2-15/16"	4"
	PC-25-014	PT-25-014		7/8"	n/a	4-1/2"
	PC-25-016	PT-25-016		1"	n/a	4-1/2"
	PC-25-020	PT-25-020		1-1/4"	n/a	5"
	PC-25-024	PT-25-024		1-1/2"	n/a	5-1/2"
	PC-25-028	PT-25-028		1-3/4"	n/a	6-1/2"
	PC-25-032	PT-25-032		2"	n/a	6-1/2"

## 4-PIECE EXPANDABLE DOUBLE EASING SET

### MINI-PRO cutters

- 3 wing • 2-3/16" minor diameter
- 3/4" bore

### PRO-LINE cutters

- 3 wing • 3" minor diameter
- 1-1/4" bore

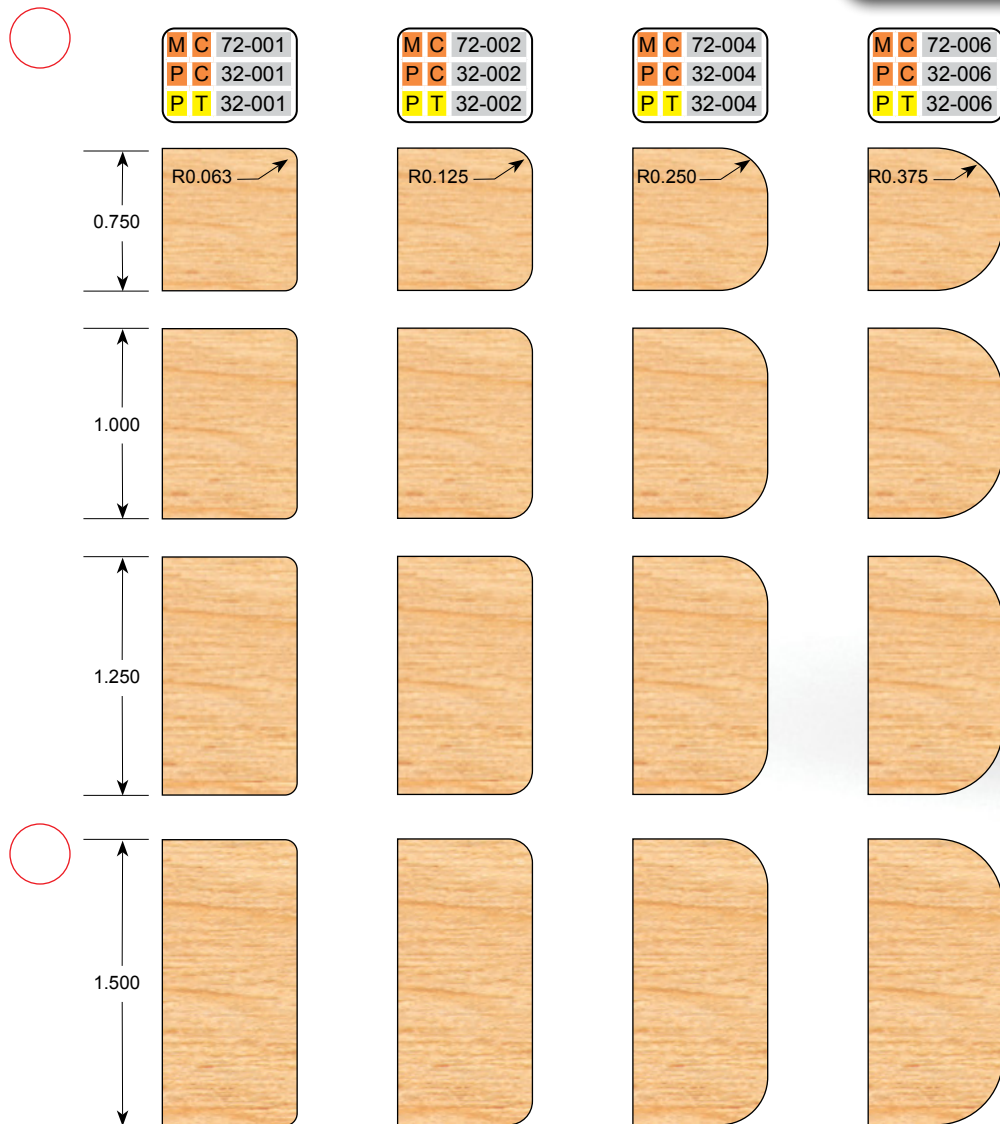

Each set includes 2 cutters and 2 spacers to cut 3/4", 1", 1-1/4" and 1-1/2" material.

## EXTENDED CORNER ROUNDS

### MINI-PRO cutters

- 3 wing • 2-15/16" diameter
- 3/4" bore

### PRO-LINE cutters

- 3 wing • 4" diameter
- 1-1/4" bore

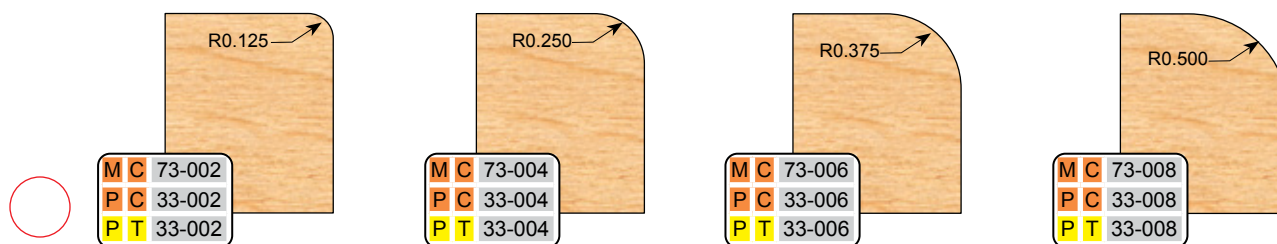

Counterclockwise rotation with face down. For up to 1-1/4" material.

## CORNER ROUNDING / COVE COMBO

### MINI-PRO cutters

- 3 wing • 2-15/16" diameter
- 3/4" bore

### PRO-LINE cutters

- 3 wing • 4" diameter
- 1-1/4" bore

MC 74-002  
PC 34-002  
PT 34-002

MC 74-004  
PC 34-004  
PT 34-004

MC 74-006  
PC 34-006  
PT 34-006

MC 74-008  
PC 34-008  
PT 34-008

PC 34-012  
PT 34-012

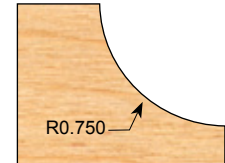
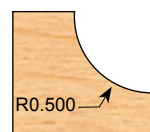
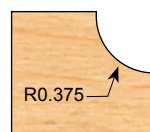
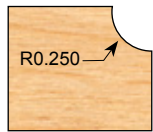
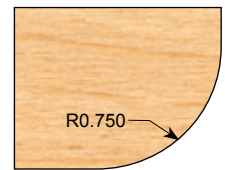
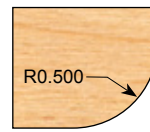
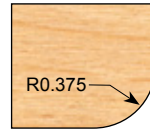
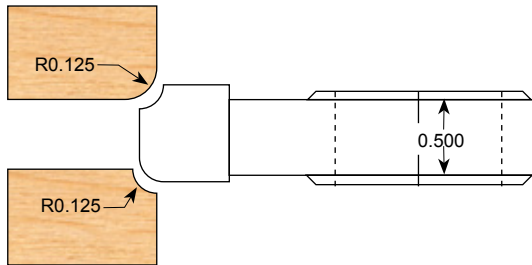

## CORNER ROUNDING COMBO

### MINI-PRO cutters

- 3 wing
- 3/4" bore

### PRO-LINE cutters

- 3 wing
- 1-1/4" bore

MC 75-048  
PC 35-048  
PT 35-048

MC 75-612  
PC 35-612  
PT 35-612

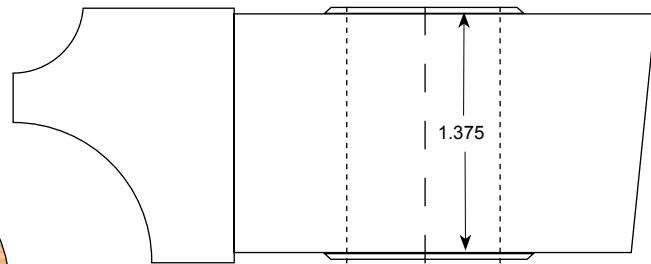
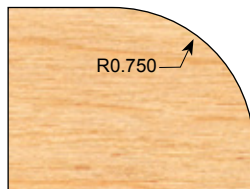
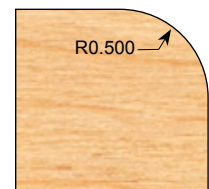
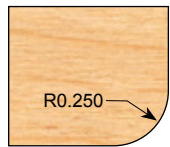

## TABLE SAW BEAD CUTTERS

- 6 wing
- 5/8" bore
- 8" diameter

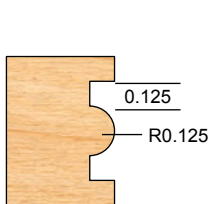

TSB-2

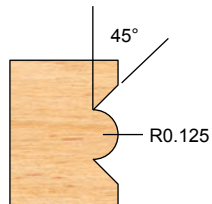

TSB-1



TSB-3

## BALL BEARING RUB COLLARS

NUMBER	BORE	DIAM.
AM-90-026	3/4"	1-5/8"
AM-90-027	3/4"	1-11/16"
AM-90-028	3/4"	1-3/4"
AM-90-032	3/4"	2"
AM-90-033	3/4"	2-1/16"
AM-90-035	3/4"	2-3/16"
AM-90-036	3/4"	2-1/4"
AM-90-039	3/4"	2-7/16"
AM-90-040	3/4"	2-1/2"
AM-90-047	3/4"	2-15/16"
AM-90-048	3/4"	3"

NUMBER	BORE	DIAM.
AP-90-036	1-1/4"	2-1/4"
AP-90-040	1-1/4"	2-1/2"
AP-90-044	1-1/4"	2-3/4"
AP-90-048	1-1/4"	3"
AP-90-049	1-1/4"	3-1/16"
AP-90-052	1-1/4"	3-1/4"
AP-90-056	1-1/4"	3-1/2"
AP-90-060	1-1/4"	3-3/4"
AP-90-064	1-1/4"	4"
AP-90-066	1-1/4"	4-1/8"
AP-90-068	1-1/4"	4-1/4"
AP-90-072	1-1/4"	4-1/2"



## RUB SPACERS FOR COPE & PATTERN

<b>A M</b> 50-803
<b>A P</b> 10-803

1/4" x 3/8"  
tongue

<b>A M</b> 50-801
<b>A P</b> 10-801

1/4" x 1/2"  
tongue

<b>A M</b> 50-806
<b>A P</b> 10-806

5.5 x 3/8"  
tongue

<b>A M</b> 50-807
<b>A P</b> 10-807

5.5 x 1/2"  
tongue



Optional rub spacer available for M-50 and P-10 series cope & pattern sets. Replaces center cutter on cope side.

## T-BUSHINGS

Choose from

- **Long Style** - for 3 to 6 Cutter Sets. Consists of 1 long and 1 short T-Bushing.
- **Short Style** - for Single Cutters. Consists of 2 short T-Bushings.
- **Double Sided** - to run between Cutter and Bearing.

### Long Style

NUMBER	I.D.	O.D.
AM-91-008	1/2"	3/4"
AX-91-012	3/4"	1"
AP-91-012	3/4"	1-1/4"
AP-91-016	1"	1-1/4"
AP-91-016 XL*	1"	1-1/4"
AP-91-017	30mm	1-1/4"
AP-91-018	1-1/8"	1-1/4"
AP-91-024	1-1/4"	1-1/2"
AP-91-025	1-1/4"	40mm
AP-91-029	1-1/4"	1-13/16"

### Short Style

NUMBER	I.D.	O.D.
AM-92-008	1/2"	3/4"
AX-92-012	3/4"	1"
AP-92-008	1/2"	1-1/4"
AP-92-012	3/4"	1-1/4"
AP-92-016	1"	1-1/4"
AP-92-017	30mm	1-1/4"
AP-92-018	1-1/8"	1-1/4"
AP-92-024	1-1/4"	1-1/2"
AP-92-025	1-1/4"	40mm
AP-92-029	1-1/4"	1-13/16"

### Double Sided

NUMBER	I.D.	O.D.
AM-93-008	1/2"	3/4"
AX-93-008	1/2"	1"
AX-93-012	3/4"	1"
AP-93-012	3/4"	1-1/4"
AP-93-016	1"	1-1/4"
AP-93-018	1-1/8"	1-1/4"
AP-93-024	1-1/4"	1-1/2"
AP-93-025	1-1/4"	40mm
AP-93-029	1-1/4"	1-13/16"

## SPACERS AND SHIMS

### Spacers

NUMBER	BORE	WIDTH
AM-94-001	3/4"	1/16"
AM-94-002	3/4"	1/8"
AM-94-003	3/4"	3/16"
AM-94-004	3/4"	1/4"
AM-94-005	3/4"	5/16"
AM-94-006	3/4"	3/8"
AM-94-007	3/4"	7/16"
AM-94-008	3/4"	1/2"
AM-94-009	3/4"	9/16"
AM-94-010	3/4"	5/8"
AM-94-012	3/4"	3/4"
AM-94-016	3/4"	1"
AP-94-001	1-1/4"	1/16"
AP-94-002	1-1/4"	1/8"
AP-94-003	1-1/4"	3/16"
AP-94-004	1-1/4"	1/4"
AP-94-005	1-1/4"	5/16"
AP-94-006	1-1/4"	3/8"
AP-94-007	1-1/4"	7/16"
AP-94-008	1-1/4"	1/2"
AP-94-009	1-1/4"	9/16"
AP-94-010	1-1/4"	5/8"
AP-94-012	1-1/4"	3/4"
AP-94-016	1-1/4"	1"

**Spacers** - Used in a wide range of woodworking applications.

**Shims** - Sets of 48 color-coded plastic shims for various spacing needs.

### Shims

NUMBER	BORE	QTY.	COLOR	THICKNESS	QTY.	COLOR	THICKNESS
AM-95-008	1/2"	6	Green	.003"	6	Black	.0125
AP-95-016	1"	6	Matte	.0075"	6	Yellow	.020
AP-95-018	1-1/8"	6	Brown	.010"	6	Coral	.030

**Shims** - Sets of 20 metal shims in five thicknesses.

### Metal Shims

NUMBER	BORE	QTY.	THICKNESS
AM-95-012-M	3/4"	4	.003"
AP-95-020-M	1-1/4"	4	.005"
		4	.010"
		4	.015"
		4	.020"

Many of our sets may be run in multiple configurations, or require very careful set-ups. Scan the QR code to get additional information. As always, feel free to call us with any questions.



Setting up a Lock Mitre Set

Cope and Pattern Stacking Instructions

V Panel Stacking Instructions



Flooring Set Stacking Instructions

Shaper Spindle Alignment

***All use the same QR Code***

Cope and Pattern Trouble Shooting





Since 1975, Freeborn Tool Co., Inc. has maintained a focus on making tools that perfectly fit the needs of its customers in the woodworking and manufacturing industries.

FOLLOW US



FACEBOOK



INSTAGRAM



YOUTUBE



[WWW.FREEBORNTOOL.COM](http://WWW.FREEBORNTOOL.COM)

3304 E. FERRY AVE.  
SPOKANE, WA 99202  
VERSION 0123

