

CHAMFERING IS NOT RECOMMENDED FOR STACKSTONE, INFINITI STONE AND CONCERTO

NOTES:

1. ALL DIMENSIONS ARE IN mm. UNLESS OTHERWISE STATED OR SPECIFIED AND NOTED.
2. ANY DISCREPANCIES ON THE DRAWINGS TO BE REPORTED IMMEDIATELY TO THE MCM SOLUTION TEAM.
3. THE CONTRACTOR IS RESPONSIBLE FOR THE DIMENSIONAL ACCURACY OF THE WORKS. DIMENSIONS TO BE CHECKED ON SITE PRIOR TO WORK COMMENCEMENT.
4. THE CONTRACTOR IS RESPONSIBLE FOR THE CO-ORDINATION OF SERVICES INTO THE WORKS AS MAY BE REQUIRED.
5. DRAWINGS ARE TO BE READ IN CONJUNCTION WITH THE OTHER ELECTRICAL AND PLUMBING CONSULTANTS.

MATERIAL SPECIFICATION

APPLICATION DETAILS	WET CLADDING
MCM TILES	VARYING SIZES
SPACING	DESIGN DEPENDANT : BUTT JOINT, HAIRLINE JOINT, 4-10 MM GROOVES
PROTECTIVE COATINGS	PU COATING/SEALERS RECOMMENDED ON HIGH TRAFFIC AREAS AND FLOORING.
ADHESIVES	CEMENT BASED OR EPOXY BASED ADHESIVE- DEPENDING ON THE SUSTRATE
GROUTS	CEMENT BASED OR EPOXY BASED GROUTS (DEPENDING ON THE SUSTRATE) AS PER ARCHITECTS COLOR CHOICE

NOTES :

- The substrate should be levelled and cleaned.
- Applicator should wear gloves while laying MCM panels and make sure there are no dirt stains or smudges on the sheets during installation.
- For high traffic areas, Wet areas and flooring, apply 2 Coats of protective coating on the MCM panels before installation using roller brush.
- Type of ADHESIVES to be chosen according to the substrate.
- Use SPACERS to maintain the groove thickness throughout while installing.
- Use a MASKING TAPE along the periphery of the MCM panels to secure the edges before grouting.
- Use a Sponge to remove any dirty blots off the installed MCM panels.

IN CASE OF ANY QUERIES ,CONTACT THE MCM TECHNICAL TEAM.

DWG TITLE:
MCM PANELS EDGE FINISHING

DWG CODE:		PROJECT NO:	000000000
DWG NO:	1	DATE:	19-09-2016
DESIGN BY:	NJ	SCALE:	N.T.S
CHECKED BY:	BS		SHEET NO.
APPROVED BY:	BS		1 OF 3



CHAMFERING OF SHEET EDGE WITH GRINDER

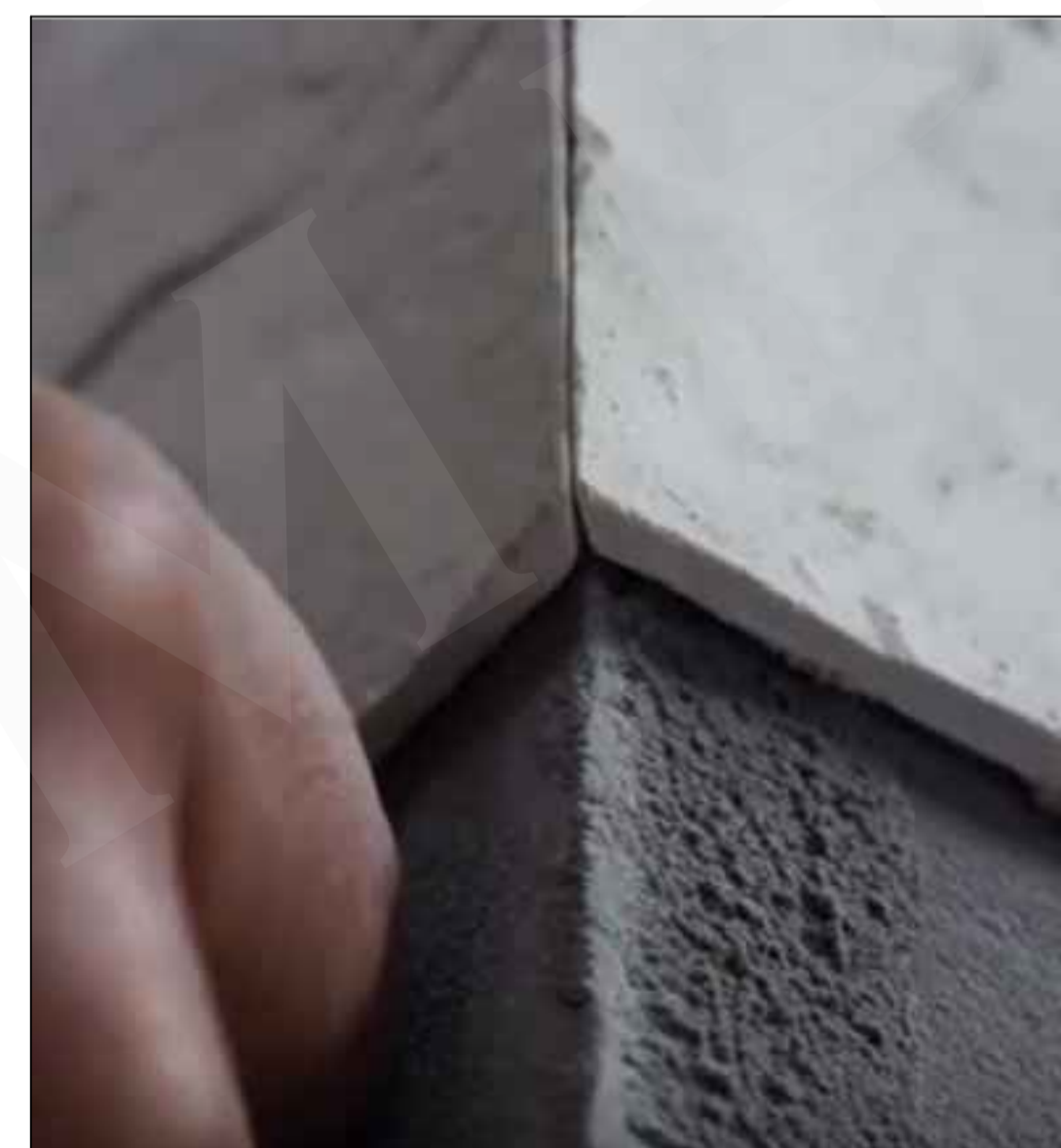

PLACING THE SHEETS AFTER CHAMFERING



GROUTING AT THE JOINT



FINISHED PICTURE

MCM PANELS EDGE FINISHING

OPTION 1 - 45 DEGREE CHAMFER

NOTE :

- Our products contain few Residual mesh fringed, small variation in size (on diagonal less than 2 mm) ,small air holes or surface anomalies and some color variation.
- These variations are intentional and do not affect the installation, and add to the overall character of the stone.
- We recommend the Authorized executive from the respective adhesive company to verify the adhesive, substrate and installation method prior to fixing MCM Products.



MCM INDIA

101-103, Damji Shamji Udyog Bhavan, Veera Desai Road, Andheri (west), MUMBAI-400 058. Tel. No.: +91-22-26735084 / 85 Email:info@mcmcladding.com

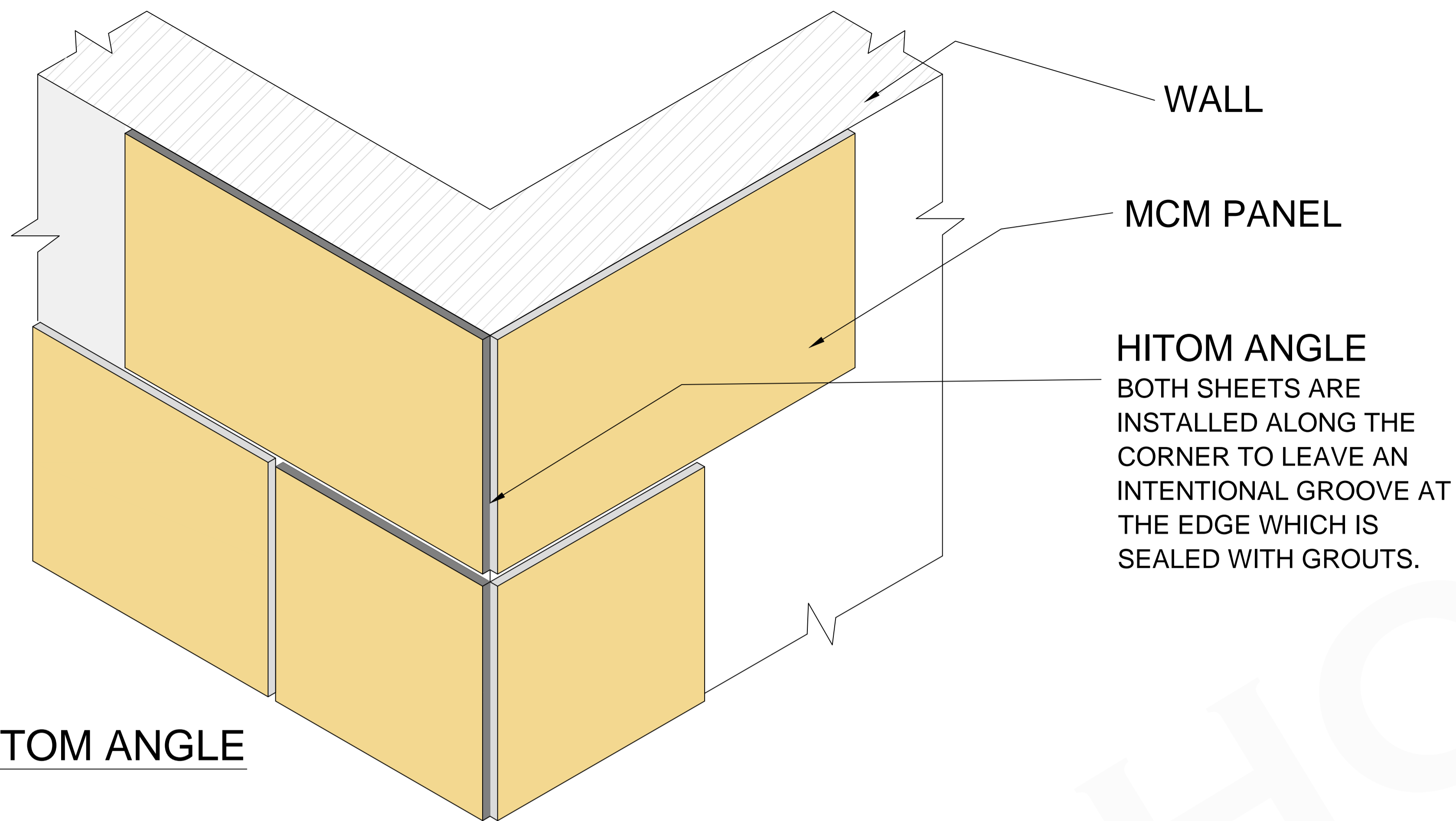

HITOM ANGLE



GROUTING AT EDGE



SMOOTHENING OF GROUTS AT EDGE



FINISHED PICTURE

MCM PANELS EDGE FINISHING

OPTION 2 - HITOM ANGLE

- NOTE :**
- Our products contain few Residual mesh fringed,small variation in size (on diagonal less than 2 mm) ,small air holes or surface anomalies and some color variation.
 - These variations are intentional and do not affect the installation, and add to the overall character of the stone.
 - We recommend the Authorized executive from the respective adhesive company to verify the adhesive, substrate and installation method prior to fixing MCM Products.

NOTES:

1. ALL DIMENSIONS ARE IN mm. UNLESS OTHERWISE STATED OR SPECIFIED AND NOTED.
2. ANY DISCREPANCIES ON THE DRAWINGS TO BE REPORTED IMMEDIATELY TO THE MCM SOLUTION TEAM.
3. THE CONTRACTOR IS RESPONSIBLE FOR THE DIMENSIONAL ACCURACY OF THE WORKS. DIMENSIONS TO BE CHECKED ON SITE PRIOR TO WORK COMMENCEMENT.
4. THE CONTRACTOR IS RESPONSIBLE FOR THE CO-ORDINATION OF SERVICES INTO THE WORKS AS MAY BE REQUIRED.
5. DRAWINGS ARE TO BE READ IN CONJUNCTION WITH THE OTHER ELECTRICAL AND PLUMBING CONSULTANTS.

MATERIAL SPECIFICATION

APPLICATION DETAILS	WET CLADDING
MCM TILES	VARYING SIZES
SPACING	DESIGN DEPENDANT : BUTT JOINT,HAIRLINE JOINT, 4-10 MM GROOVES
PROTECTIVE COATINGS	PU COATING/SEALERS RECOMMENDED ON HIGH TRAFFIC AREAS AND FLOORING.
ADHESIVES	CEMENT BASED OR EPOXY BASED ADHESIVE- DEPENDING ON THE SUSTRATE
GROUTS	CEMENT BASED OR EPOXY BASED GROUTS (DEPENDING ON THE SUSTRATE) AS PER ARCHITECTS COLOR CHOICE

NOTES :

- The substrate should be levelled and cleaned.
- Applicator should wear gloves while laying MCM panels and make sure there are no dirt stains or smudges on the sheets during installation.
- For high traffic areas,Wet areas and flooring,apply 2 Coats of protective coating on the MCM panels before installation using roller brush.
- Type of ADHESIVES to be chosen according to the substrate.
- Use SPACERS to maintain the groove thickness throughout while installing.
- Use a MASKING TAPE along the periphery of the MCM panels to secure the edges before grouting.
- Use a Sponge to remove any dirty blots off the installed MCM panels.

IN CASE OF ANY QUERIES ,CONTACT THE MCM TECHNICAL TEAM.

DWG TITLE:
MCM PANELS EDGE FINISHING

DWG CODE:		PROJECT NO:	000000000
DWG NO:	2	DATE:	19-09-2016
DESIGN BY:	NJ	SCALE:	N.T.S
CHECKED BY:	BS		SHEET NO.
APPROVED BY:	BS		2 OF 3



MCM INDIA

101-103, Damji Shamji Udyog Bhavan, Veera Desai Road, Andheri (west), MUMBAI-400 058.
Tel. No.: +91-22-26735084 / 85
Email:info@mcmcladding.com

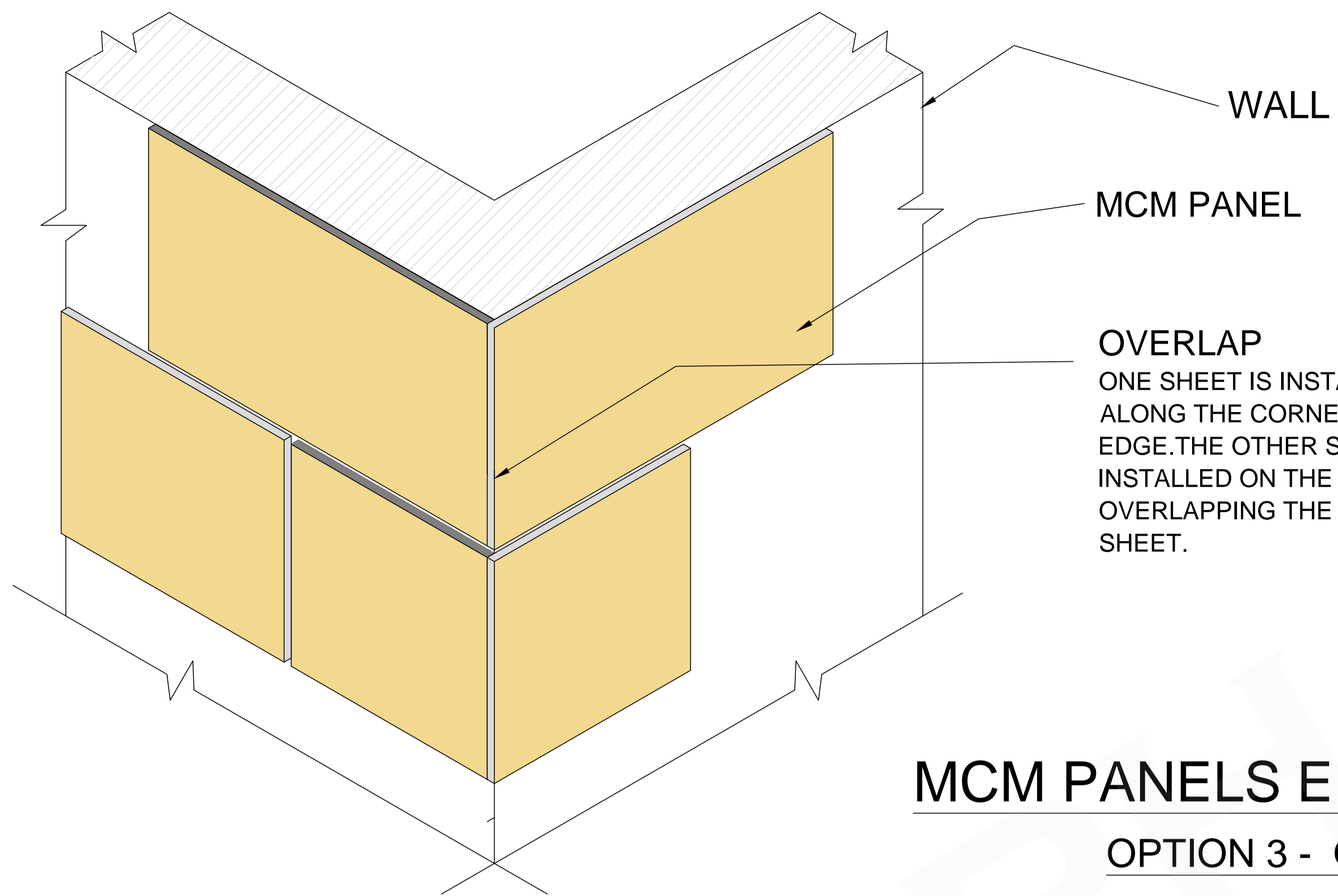

MCM PANELS EDGE FINISHING

OPTION 3 - OVERLAP

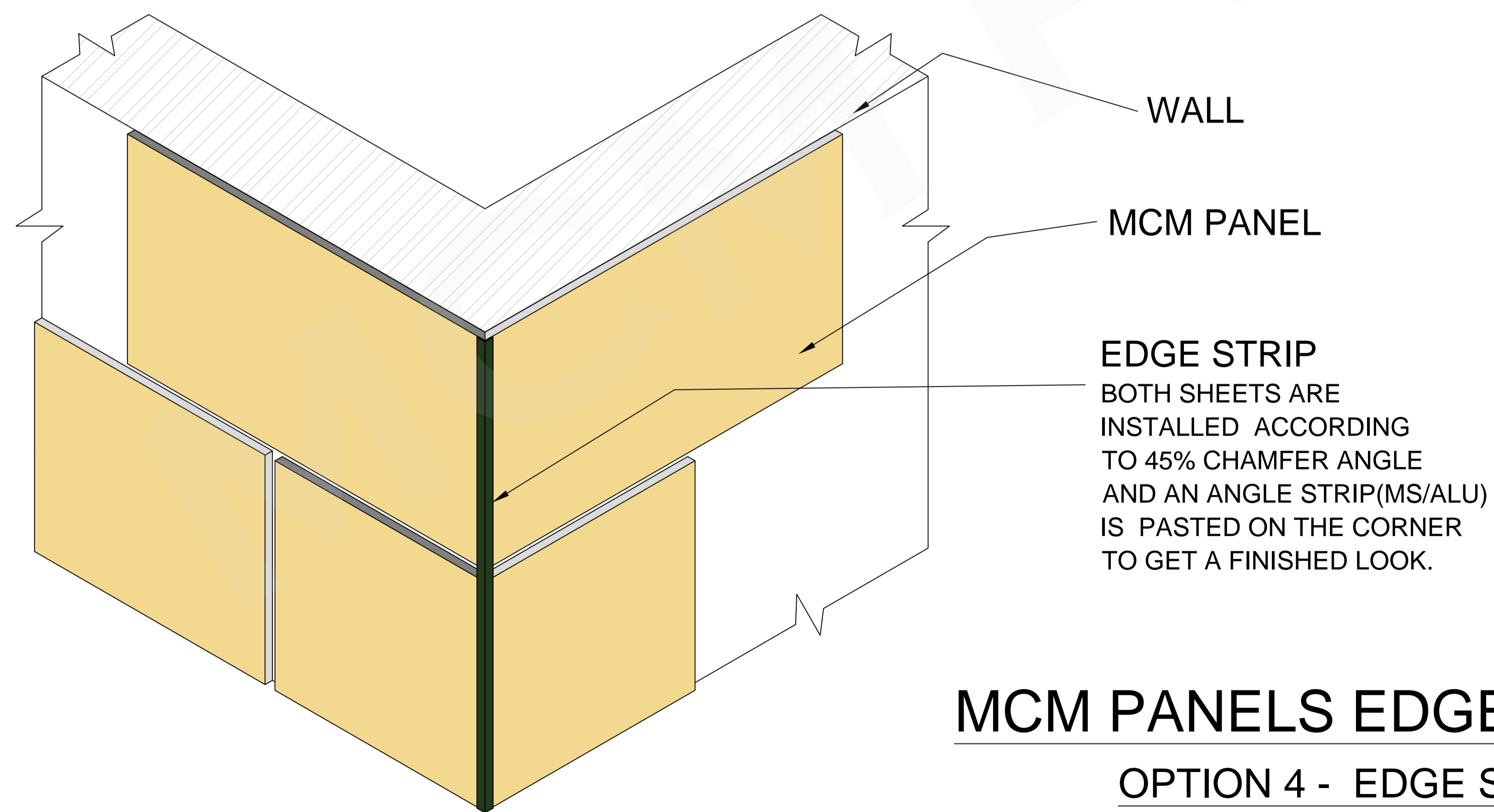

MCM PANELS EDGE FINISHING

OPTION 4 - EDGE STRIP

- NOTE :**
- Our products contain few Residual mesh fringed, small variation in size (on diagonal less than 2 mm), small air holes or surface anomalies and some color variation.
 - These variations are intentional and do not affect the installation, and add to the overall character of the stone.
 - We recommend the Authorized executive from the respective adhesive company to verify the adhesive, substrate and installation method prior to fixing MCM Products.

NOTES:

1. ALL DIMENSIONS ARE IN mm. UNLESS OTHERWISE STATED OR SPECIFIED AND NOTED.
2. ANY DISCREPANCIES ON THE DRAWINGS TO BE REPORTED IMMEDIATELY TO THE MCM SOLUTION TEAM.
3. THE CONTRACTOR IS RESPONSIBLE FOR THE DIMENSIONAL ACCURACY OF THE WORKS. DIMENSIONS TO BE CHECKED ON SITE PRIOR TO WORK COMMENCEMENT.
4. THE CONTRACTOR IS RESPONSIBLE FOR THE CO-ORDINATION OF SERVICES INTO THE WORKS AS MAY BE REQUIRED.
5. DRAWINGS ARE TO BE READ IN CONJUNCTION WITH THE OTHER ELECTRICAL AND PLUMBING CONSULTANTS.

MATERIAL SPECIFICATION

APPLICATION DETAILS	WET CLADDING
MCM TILES	VARYING SIZES
SPACING	DESIGN DEPENDANT : BUTT JOINT, HAIRLINE JOINT, 4-10 MM GROOVES
PROTECTIVE COATINGS	PU COATING/SEALERS RECOMMENDED ON HIGH TRAFFIC AREAS AND FLOORING.
ADHESIVES	CEMENT BASED OR EPOXY BASED ADHESIVE- DEPENDING ON THE SUSTRATE
GROUTS	CEMENT BASED OR EPOXY BASED GROUTS (DEPENDING ON THE SUSTRATE) AS PER ARCHITECTS COLOR CHOICE

NOTES :

- The substrate should be levelled and cleaned.
- Applicator should wear gloves while laying MCM panels and make sure there are no dirt stains or smudges on the sheets during installation.
- For high traffic areas, Wet areas and flooring, apply 2 Coats of protective coating on the MCM panels before installation using roller brush.
- Type of ADHESIVES to be chosen according to the substrate.
- Use SPACERS to maintain the groove thickness throughout while installing.
- Use a MASKING TAPE along the periphery of the MCM panels to secure the edges before grouting.
- Use a Sponge to remove any dirty blots off the installed MCM panels.

IN CASE OF ANY QUERIES, CONTACT THE MCM TECHNICAL TEAM.

DWG TITLE:
MCM PANELS EDGE FINISHING

DWG CODE:		PROJECT NO:	000000000
DWG NO:	3	DATE:	19-09-2016
DESIGN BY:	NJ	SCALE:	N.T.S
CHECKED BY:	BS		SHEET NO.
APPROVED BY:	BS		3 OF 3



MCM INDIA

101-103, Damji Shamji Udyog
Bhavan, Veera Desai Road,
Andheri (west), MUMBAI-400 058.
Tel. No.: +91-22-26735084 / 85
Email: info@mcmcladding.com