

ALL DIMENSIONS IN MILLIMETRES
REMOVE ALL SHARP EDGES

THIRD ANGLE PROJECTION
DO NOT SCALE DRAWING

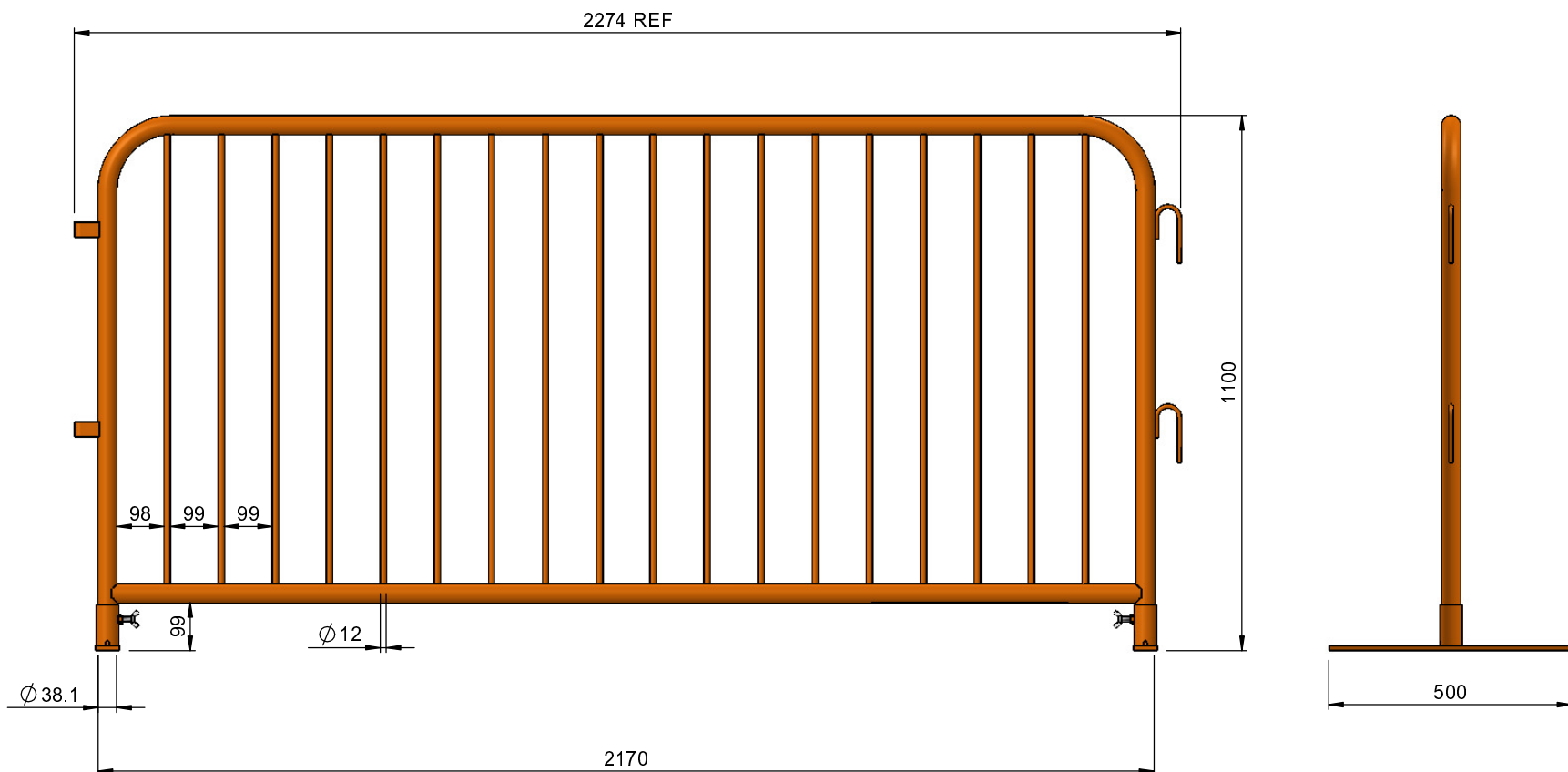

CUSTOMER DRAWING APPROVAL	
Customer Reference:	_____
Company Name:	_____
Signature:	_____ Date: _____
Print Name:	_____

PRELIMINARY

P2	12/7/16	ISSUED FOR APPR			
		ED FOR APPR			
		ISSUED FOR APPR			
		ISSUED FOR APPR			

TOLERANCES - UNLESS STATED OTHERWISE	
UNTOLERANCED DIMENSIONS	+/- 2mm
CUTTING LENGTHS	+/- 2mm
FABRICATION	
UP TO 300mm	+/- 1mm
UP TO 1000mm	+/- 2mm
1001mm & ABOVE	+/- 3mm
ANGULAR	+/- 1°
MACHINING	+/- 0.2mm
GAUGE	+/- 10%
WEIGHT	+/- 10% (DUE TO MATERIAL PROPERTIES & TOLERANCES)

TITLE: BAR BARRIER 2.3m (FAHEY)			
NAME	SIGNATURE	DATE	MATERIAL:
G. CRICK		11/7/16	CARBON STEEL PRE-GALVANISED
CHK'D			
FINISH: SEE NOTE			
WEIGHT: 11.8 Kg			

FINISH NOTE:
PAINT POLYESTER POWDER COAT.
COLOUR: ORANGE (RAL????)

Drw / Stockcode No.	Revision
ZND1043	P2

THE COMPANY RETAIN THE RIGHT TO PERIODICALLY ALTER INFORMATION WITHIN THIS DRAWING SHEET AND WILL ATTEMPT TO NOTIFY ALL PARTIES CONCERNED OF ANY CHANGES AND THE INFORMATION ON THIS SHEET SHOULD NOT BE REPRODUCED WITHOUT THEIR WRITTEN CONSENT.

ALL DIMENSIONS IN MILLIMETRES
REMOVE ALL SHARP EDGES

THIRD ANGLE PROJECTION
DO NOT SCALE DRAWING

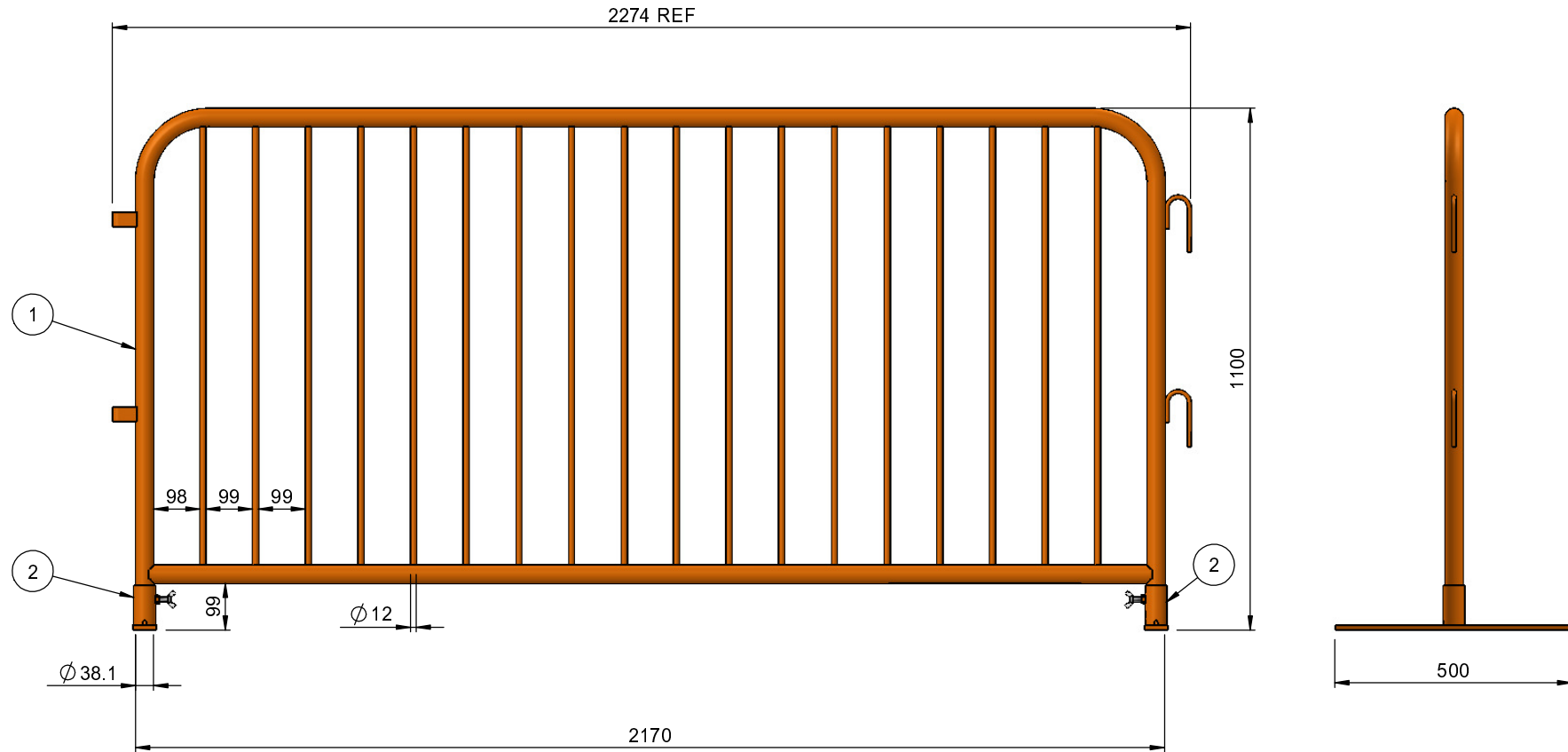

ITEM No.	PART No.	DESCRIPTION	QTY
1	ZND1043-1	2.3m BAR BARRIER	1
2	ZND1043-2	SINGLE FLAT FOOT	2

PRELIMINARY

CUSTOMER DRAWING APPROVAL

Customer Reference: _____

Company Name: _____

Signature: _____ Date: _____

Print Name: _____

FINISH NOTE:
PAINT POLYESTER POWDER COAT.
COLOUR: ORANGE (RAL2009)

TOLERANCES - UNLESS STATED OTHERWISE	
UNTOLERANCED DIMENSIONS	+/- 2mm
CUTTING LENGTHS	+/- 2mm
FABRICATION	
UP TO 300mm	+/- 1mm
UP TO 1000mm	+/- 2mm
1001mm & ABOVE	+/- 3mm
ANGULAR	+/- 1°
MACHINING	+/- 0.2mm
GAUGE	+/- 10%
WEIGHT	+/- 10% (DUE TO MATERIAL PROPERTIES & TOLERANCES)

TITLE: **BAR BARRIER 2.3m (FAHEY) FAB SHT 1**

NAME	SIGNATURE	DATE
DRAWN	G. CRICK	11/7/16
CHK'D		

MATERIAL: **CARBON STEEL PRE-GALVANISED**

FINISH: **SEE NOTE**

REV	DATE	ISSUE DESCRIPTION
P1	11/7/16	ISSUED FOR APPR
P2	12/7/16	ISSUED FOR APPR

Drw / Stockcode No. **ZND1043 - FAB SHT 1** P2

Revision

THE COMPANY RETAIN THE RIGHT TO PERIODICALLY ALTER INFORMATION WITHIN THIS DRAWING SHEET AND WILL ATTEMPT TO NOTIFY ALL PARTIES CONCERNED OF ANY CHANGES AND THE INFORMATION ON THIS SHEET SHOULD NOT BE REPRODUCED WITHOUT THEIR WRITTEN CONSENT.

1 ALL DIMENSIONS IN MILLIMETRES
REMOVE ALL SHARP EDGES

2 DO NOT JOIN MATERIAL TOGETHER
TO MAKE INDIVIDUAL ITEMS

8 THIRD ANGLE PROJECTION
DO NOT SCALE DRAWING

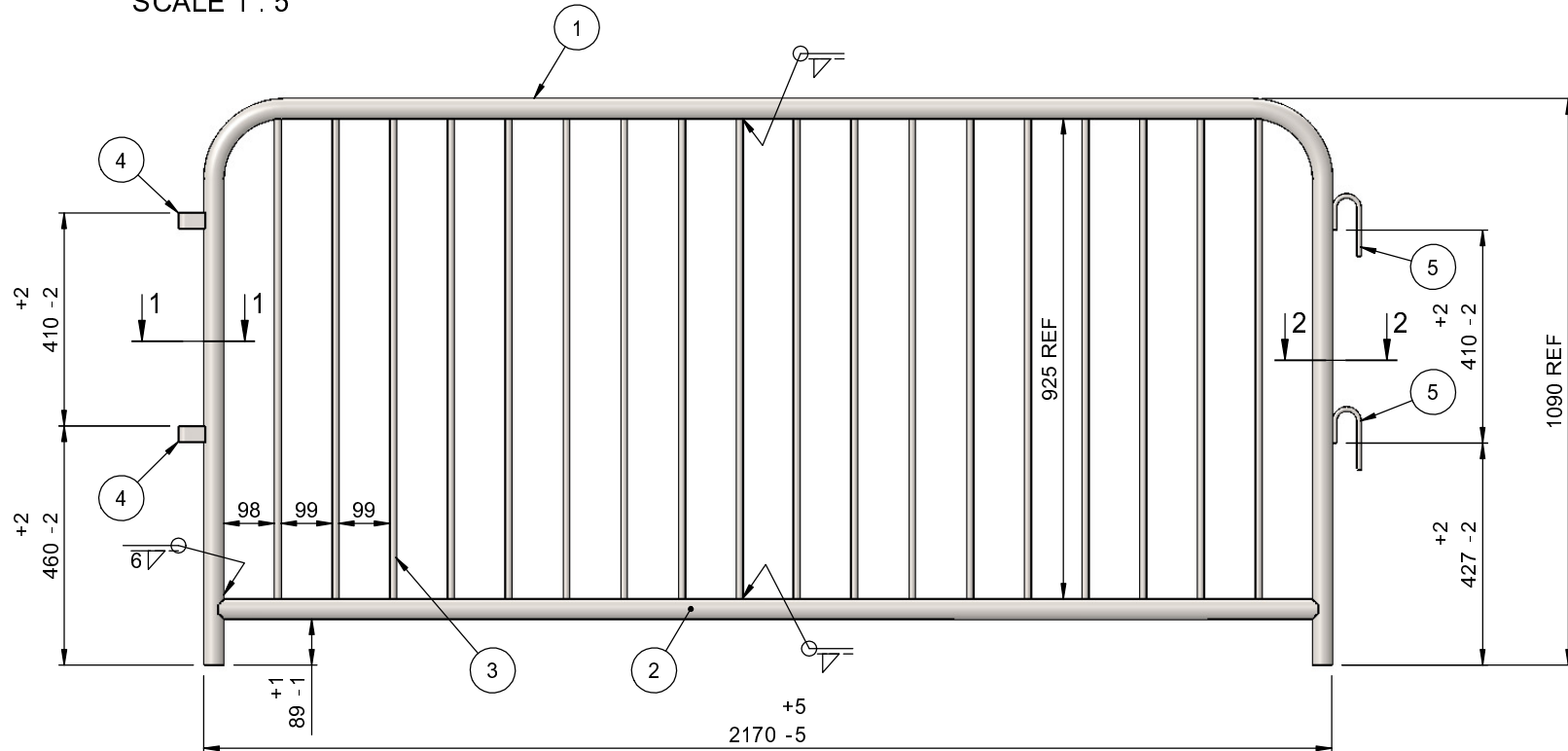
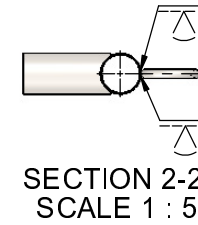
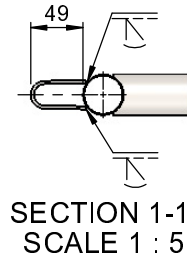

CUSTOMER DRAWING APPROVAL

Customer Reference: _____

Company Name: _____

Signature: _____ Date: _____

Print Name: _____

PRELIMINARY

ITEM No.	PART No.	DESCRIPTION	QTY
1	ZND1043-1-1	FRAME TUBE	1
2	ZND1043-1-2	HORIZONTAL TUBE	1
3	ZND1043-1-3	VERTICAL TUBE	18
4	02551030	EYE (STANDARD)	2
5	03051030	HOOK (STRAIGHT)	2

TOLERANCES - UNLESS STATED OTHERWISE

UNTOLERANCED DIMENSIONS	+/- 2mm
CUTTING LENGTHS	+/- 2mm
FABRICATION	
UP TO 300mm	+/- 1mm
UP TO 1000mm	+/- 2mm
1001mm & ABOVE	+/- 3mm
ANGULAR	+/- 1°
MACHINING	+/- 0.2mm
GAUGE	+/- 10%
WEIGHT	+/- 10% (DUE TO MATERIAL PROPERTIES & TOLERANCES)

TITLE: **BAR BARRIER 2.3m (FAHEY) - FABRICATION**

NAME	SIGNATURE	DATE	MATERIAL:
G. CRICK		11/7/16	CARBON STEEL PRE-GALVANISED
CHK'D			
FINISH:	NONE		

P1	11/7/16	ISSUED FOR APPROVAL	GC		
P2	13/7/16	ISSUED FOR APPROVAL	GC		
REV	DATE	DESCRIPTION	DRN	CHKD	APP

THE COMPANY RETAIN THE RIGHT TO PERIODICALLY ALTER INFORMATION WITHIN THIS DRAWING SHEET AND WILL ATTEMPT TO NOTIFY ALL PARTIES CONCERNED OF ANY CHANGES AND THE INFORMATION ON THIS SHEET SHOULD NOT BE REPRODUCED WITHOUT THEIR WRITTEN CONSENT.

Draw / Stockcode No. **ZND1043-1** Revision **P2**

1
ALL DIMENSIONS IN MILLIMETRES
REMOVE ALL SHARP EDGES

2
DO NOT JOIN MATERIAL TOGETHER
TO MAKE INDIVIDUAL ITEMS

8
THIRD ANGLE PROJECTION
DO NOT SCALE DRAWING

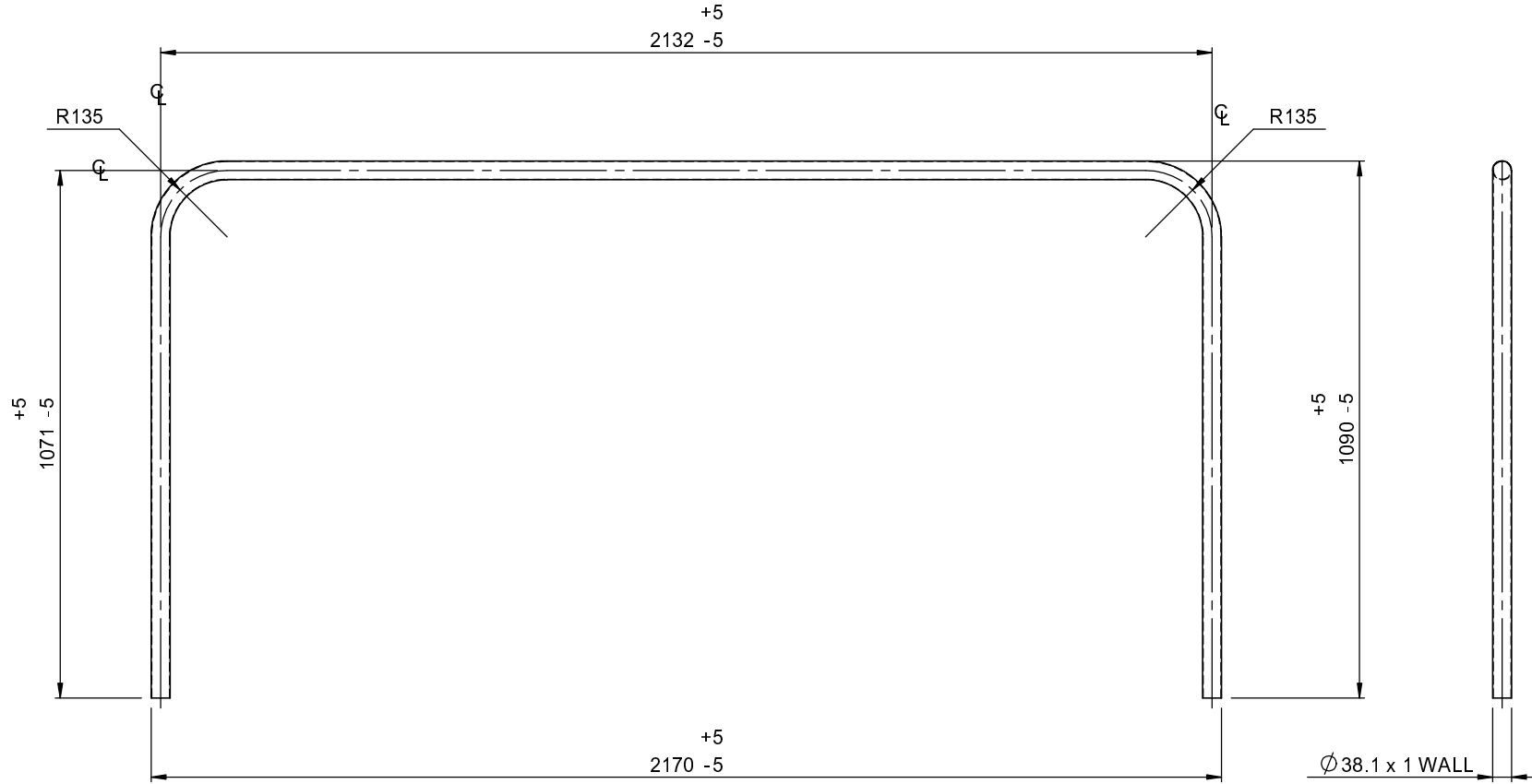

CUSTOMER DRAWING APPROVAL	
Customer Reference:	_____
Company Name:	_____
Signature:	_____ Date: _____
Print Name:	_____

PRELIMINARY

TOLERANCES - UNLESS STATED OTHERWISE	
UNTOLERANCED DIMENSIONS	+/- 2mm
CUTTING LENGTHS	+/- 2mm
FABRICATION	
UP TO 300mm	+/- 1mm
UP TO 1000mm	+/- 2mm
1001mm & ABOVE	+/- 3mm
ANGULAR	+/- 1°
MACHINING	+/- 0.2mm
GAUGE	+/- 10%
WEIGHT	+/- 10% (DUE TO MATERIAL PROPERTIES & TOLERANCES)

TITLE: BAR BARRIER 2.3m FRAME TUBE				P2	13/7/16
DRAWN: G. CRICK				REV	DATE
SIGNATURE: _____					
DATE: 13/7/16					
MATERIAL: CARBON STEEL PRE-GALVANISED					
FINISH: NONE					

ED FOR APPR					
DESCRIPTION					
ISSU OVAL					
CC					
DN C KDAP P					
Drw / Stockcode No.		ZND1043-1-1		Revision	
				P2	

THE COMPANY RETAIN THE RIGHT TO PERIODICALLY ALTER INFORMATION WITHIN THIS DRAWING SHEET AND WILL ATTEMPT TO NOTIFY ALL PARTIES CONCERNED OF ANY CHANGES AND THE INFORMATION ON THIS SHEET SHOULD NOT BE REPRODUCED WITHOUT THEIR WRITTEN CONSENT.

1 2 3 4 5 6 7 8
 ALL DIMENSIONS IN MILLIMETRES
 REMOVE ALL SHARP EDGES
 DO NOT JOIN MATERIAL TOGETHER
 TO MAKE INDIVIDUAL ITEMS

THIRD ANGLE PROJECTION
 DO NOT SCALE DRAWING

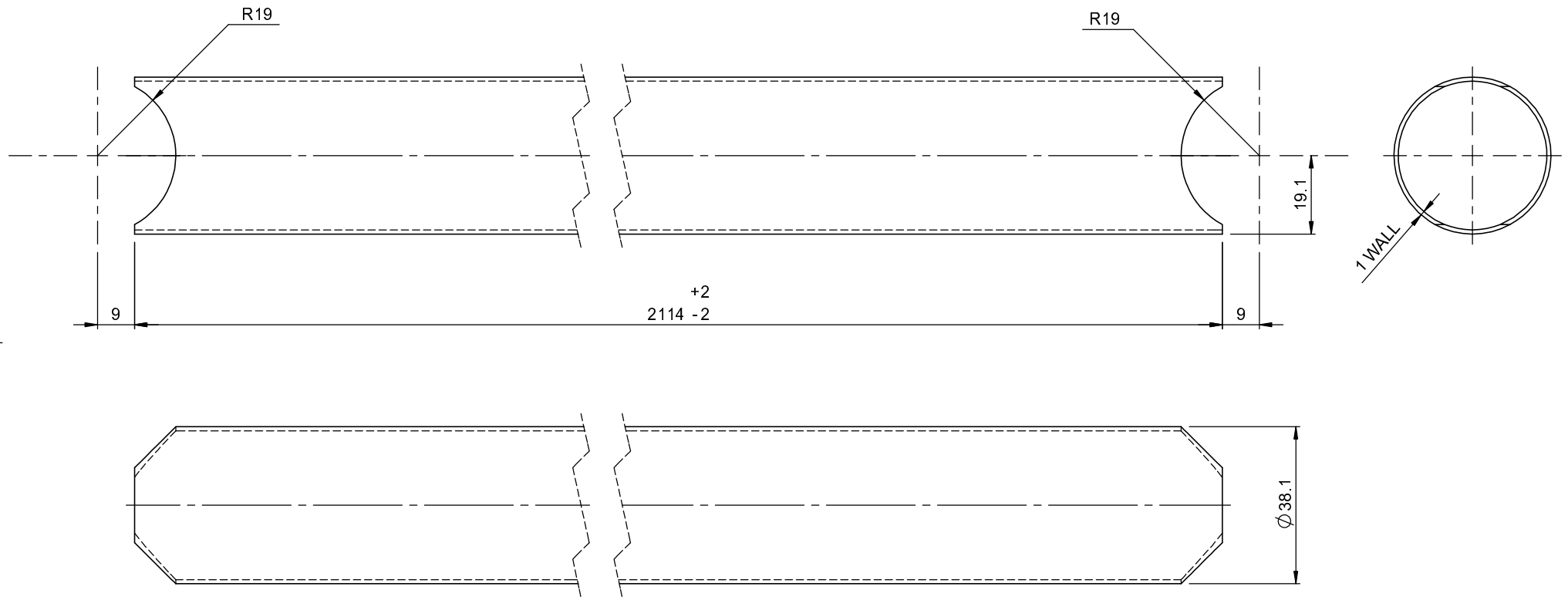

PRELIMINARY

CUSTOMER DRAWING APPROVAL

Customer Reference:

Company Name:

Signature: Date:

Print Name:

TOLERANCES - UNLESS STATED OTHERWISE	
UNTOLERANCED DIMENSIONS	+/- 2mm
CUTTING LENGTHS	+/- 2mm
FABRICATION	
UP TO 300mm	+/- 1mm
UP TO 1000mm	+/- 2mm
1001mm & ABOVE	+/- 3mm
ANGULAR	+/- 1°
MACHINING	+/- 0.2mm
GAUGE	+/- 10%
WEIGHT	+/- 10% (DUE TO MATERIAL PROPERTIES & TOLERANCES)

TITLE: **BAR BARRIER 2.3m HORIZONTAL TUBE**

REV: P1 13/7/16

NAME	SIGNATURE	DATE
DRAWN G. CRICK		13/7/16
CHK'D		

FINISH: **NONE**

MATERIAL: **CARBON STEEL PRE-GALVANISED**

ISSUED FOR APPROVAL	GC
DESCRIPTION	DRN CHKD APP
Drw / Stockcode No.	Revision
ZND1043-1-2	P2

THE COMPANY RETAIN THE RIGHT TO PERIODICALLY ALTER INFORMATION WITHIN THIS DRAWING SHEET AND WILL ATTEMPT TO NOTIFY ALL PARTIES CONCERNED OF ANY CHANGES AND THE INFORMATION ON THIS SHEET SHOULD NOT BE REPRODUCED WITHOUT THEIR WRITTEN CONSENT.

1
ALL DIMENSIONS IN MILLIMETRES
REMOVE ALL SHARP EDGES

2
DO NOT JOIN MATERIAL TOGETHER
TO MAKE INDIVIDUAL ITEMS

8
THIRD ANGLE PROJECTION
DO NOT SCALE DRAWING

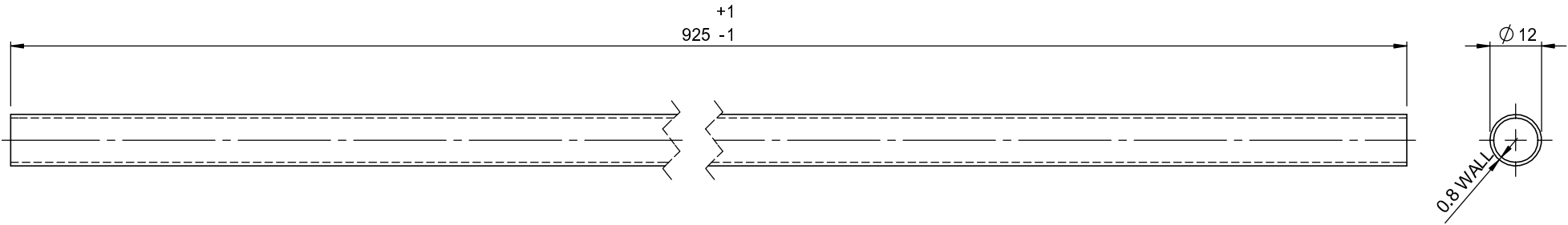

PRELIMINARY

CUSTOMER DRAWING APPROVAL

Customer Reference: _____

Company Name: _____

Signature: _____ Date: _____

Print Name: _____

TOLERANCES - UNLESS STATED OTHERWISE		
UNTOLERANCED DIMENSIONS	+/- 2mm	
CUTTING LENGTHS	+/- 2mm	
FABRICATION	UP TO 300mm	+/- 1mm
	UP TO 1000mm	+/- 2mm
	1001mm & ABOVE	+/- 3mm
	ANGULAR	+/- 1°
MACHINING	+/- 0.2mm	
GAUGE	+/- 10%	
WEIGHT	+/- 10% (DUE TO MATERIAL PROPERTIES & TOLERANCES)	

TITLE: **BAR BARRIER 2.3m VERTICAL TUBE**

REV	DATE	NAME	SIGNATURE	DATE
P1	13/7/16	G. CRICK		13/7/16

FINISH: **NONE**

MATERIAL: **CARBON STEEL PRE-GALVANISED**

ISSUED FOR APPROVAL	GC
DESCRIPTION	DRN CHKD APP
Drw / Stockcode No.	Revision
ZND1043-1-3	P2

THE COMPANY RETAIN THE RIGHT TO PERIODICALLY ALTER INFORMATION WITHIN THIS DRAWING SHEET AND WILL ATTEMPT TO NOTIFY ALL PARTIES CONCERNED OF ANY CHANGES AND THE INFORMATION ON THIS SHEET SHOULD NOT BE REPRODUCED WITHOUT THEIR WRITTEN CONSENT.

ALL DIMENSIONS IN MILLIMETRES
REMOVE ALL SHARP EDGES

THIRD ANGLE PROJECTION
DO NOT SCALE DRAWING

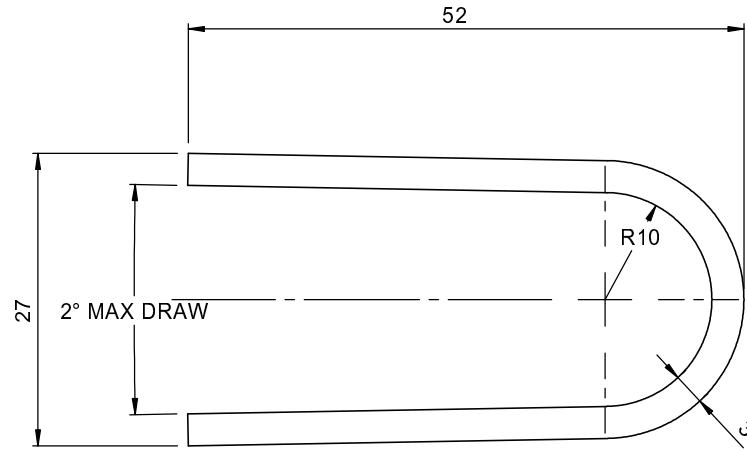

CUSTOMER DRAWING APPROVAL	
Customer Reference:	_____
Company Name:	_____
Signature:	_____ Date: _____
Print Name:	_____

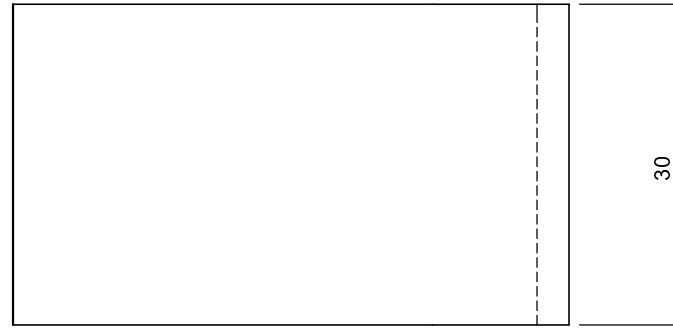
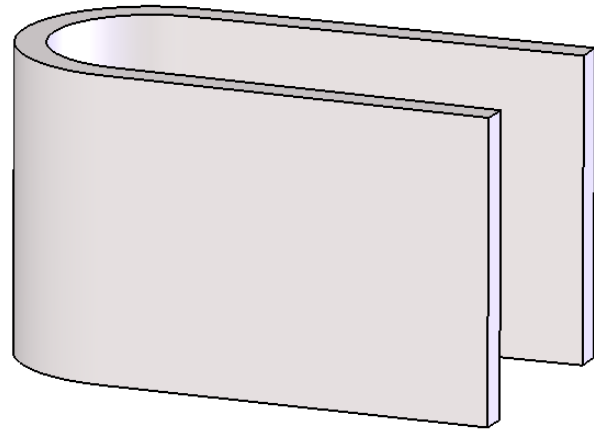

REV	DATE	DESCRIPTION	DRN	CHKD	APPR
3	6/6/16	FOR MANUFA	GC	.	.
2	ISSUED FOR	FOR MANUFA	GC	.	.

TOLERANCES - UNLESS STATED OTHERWISE		
UNTOLERANCED DIMENSIONS	+/- 2mm	
CUTTING LENGTHS	+/- 2mm	
FABRICATION	UP TO 300mm	+/- 1mm
	UP TO 1000mm	+/- 2mm
	1001mm & ABOVE	+/- 3mm
	ANGULAR	+/- 1°
MACHINING	+/- 0.2mm	
GAUGE	+/- 10%	
WEIGHT	+/- 10% (DUE TO MATERIAL PROPERTIES & TOLERANCES)	

TITLE:			
EYE (STANDARD)			
NAME	SIGNATURE	DATE	MATERIAL:
G. CRICK		4/12/7	CARBON STEEL PRE-GALVANISED
CHK'D			
FINISH:			
NONE			

Drw / Stockcode No.	Revision
02551030	3

THE COMPANY RETAIN THE RIGHT TO PERIODICALLY ALTER INFORMATION WITHIN THIS DRAWING SHEET AND WILL ATTEMPT TO NOTIFY ALL PARTIES CONCERNED OF ANY CHANGES AND THE INFORMATION ON THIS SHEET SHOULD NOT BE REPRODUCED WITHOUT THEIR WRITTEN CONSENT.

1 ALL DIMENSIONS IN MILLIMETRES
REMOVE ALL SHARP EDGES

2 DO NOT JOIN MATERIAL TOGETHER
TO MAKE INDIVIDUAL ITEMS

8 THIRD ANGLE PROJECTION
DO NOT SCALE DRAWING

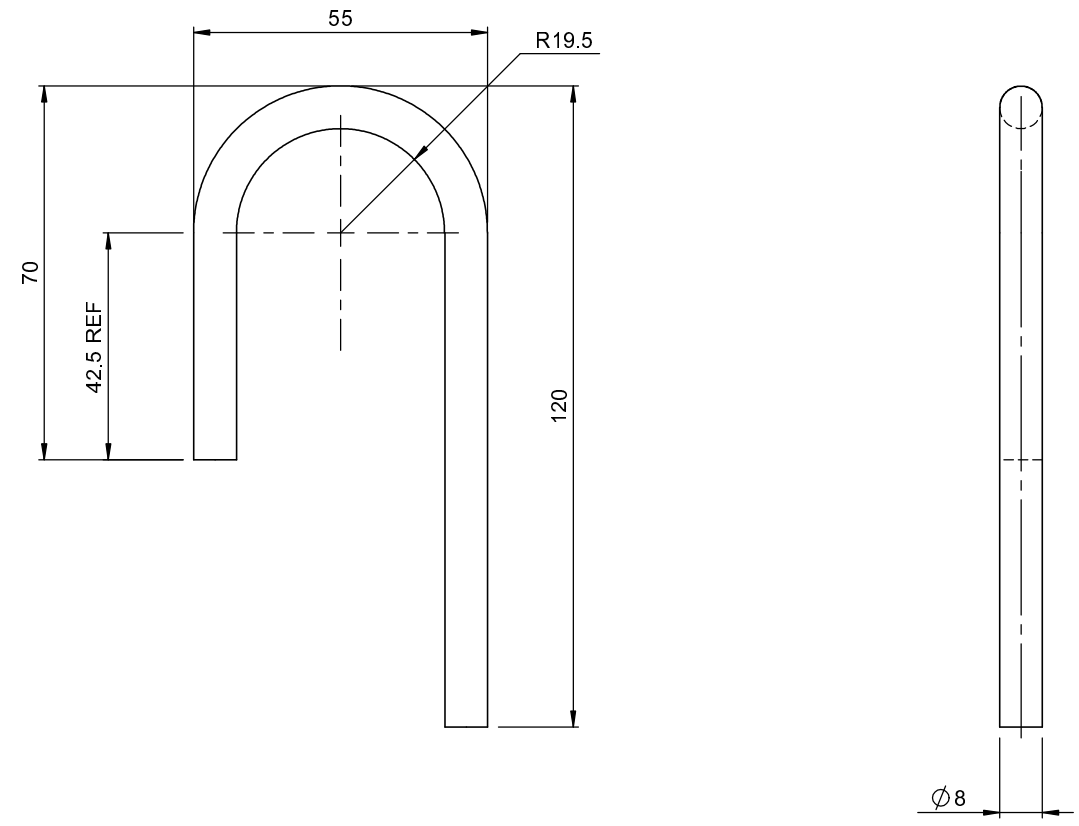

CUSTOMER DRAWING APPROVAL	
Customer Reference:	_____
Company Name:	_____
Signature:	_____ Date: _____
Print Name:	_____

REV	DATE	DESCRIPTION	GC	CHKD	APP
1	17/5/15	ISSUED FOR MANUFACTURE			
0	4/7/8	ISSUED FOR MANUFACTURE			

TOLERANCES - UNLESS STATED OTHERWISE		TITLE: BARRIER HOOK (STRAIGHT)				MATERIAL:	
UNTOLERANCED DIMENSIONS	+/- 2mm	NAME	SIGNATURE	DATE	CARBON STEEL PRE-GALVANISED		
CUTTING LENGTHS	+/- 2mm	DRAWN	G. CRICK	3/12/7			
FABRICATION	UP TO 300mm	+/- 1mm	CHK'D		NONE		
	UP TO 1000mm	+/- 2mm					
	1001mm & ABOVE	+/- 3mm					
MACHINING	+/- 0.2mm	FINISH:	NONE				
GAUGE	+/- 10%						
WEIGHT	+/- 10% (DUE TO MATERIAL PROPERTIES & TOLERANCES)						

GC DRN CHKD APP	
Drw / Stockcode No.	Revision
03051030	1

THE COMPANY RETAIN THE RIGHT TO PERIODICALLY ALTER INFORMATION WITHIN THIS DRAWING SHEET AND WILL ATTEMPT TO NOTIFY ALL PARTIES CONCERNED OF ANY CHANGES AND THE INFORMATION ON THIS SHEET SHOULD NOT BE REPRODUCED WITHOUT THEIR WRITTEN CONSENT.

1 ALL DIMENSIONS IN MILLIMETRES
REMOVE ALL SHARP EDGES

2 DO NOT JOIN MATERIAL TOGETHER
TO MAKE INDIVIDUAL ITEMS

8 THIRD ANGLE PROJECTION
DO NOT SCALE DRAWING

CUSTOMER DRAWING APPROVAL

Customer Reference: _____

Company Name: _____

Signature: _____ Date: _____

Print Name: _____

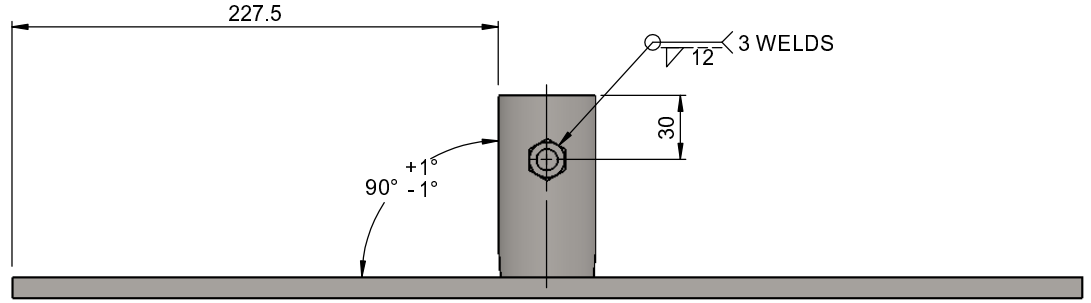
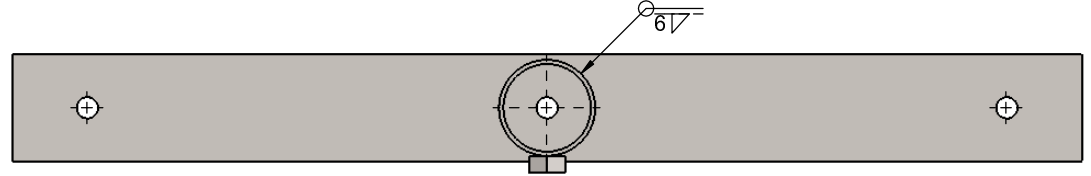

NOTE:
POSITION OF
DRAIN HOLE

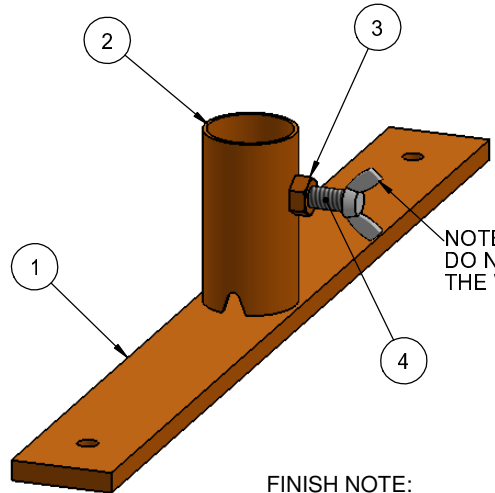
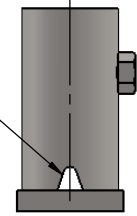

NOTE:
DO NO PAINT
THE WINGED STUD

ITEM No.	PART No.	DESCRIPTION	QTY
1	ZND1043-2-1	FLAT BAR	1
2	ZND1043-2-2	SPIGOT TUBE	1
3		M10 LOCKNUT	1
4		M10 x 30 Lg WINGED STUD	1

FINISH NOTE:
PAINT POLYESTER POWDER COAT.
COLOUR: ORANGE (RAL????)

PRELIMINARY

TOLERANCES - UNLESS STATED OTHERWISE

UNTOLERANCED DIMENSIONS	+/- 2mm
CUTTING LENGTHS	+/- 2mm
FABRICATION	
UP TO 300mm	+/- 1mm
UP TO 1000mm	+/- 2mm
1001mm & ABOVE	+/- 3mm
ANGULAR	+/- 1°
MACHINING	+/- 0.2mm
GAUGE	+/- 10%
WEIGHT	+/- 10% (DUE TO MATERIAL PROPERTIES & TOLERANCES)

TITLE: **SINGLE FLAT FOOT**

DATE: 13/7/16

NAME	SIGNATURE	DATE
DRAWN G. CRICK		13/7/16
CHK'D		

FINISH: SEE NOTE

MATERIAL: CARBON STEEL GRADES S275 & S235

ISSUED FOR APPROVAL

REV	DATE	DESCRIPTION	GC	DRN	CHKD	APP
P2	13/7/16					

Drw / Stockcode No. **ZND1043-2**

Revision **P2**

WEIGHT NOTE:
WEIGHT BEFORE GALVANISING = 2Kg
WEIGHT GALVANISED = 2.1Kg (ASSUMING 6% ADDED)

THE COMPANY RETAIN THE RIGHT TO PERIODICALLY ALTER INFORMATION WITHIN THIS DRAWING SHEET AND WILL ATTEMPT TO NOTIFY ALL PARTIES CONCERNED OF ANY CHANGES AND THE INFORMATION ON THIS SHEET SHOULD NOT BE REPRODUCED WITHOUT THEIR WRITTEN CONSENT.

1 ALL DIMENSIONS IN MILLIMETRES
REMOVE ALL SHARP EDGES

2 DO NOT JOIN MATERIAL TOGETHER
TO MAKE INDIVIDUAL ITEMS

THIRD ANGLE PROJECTION
DO NOT SCALE DRAWING

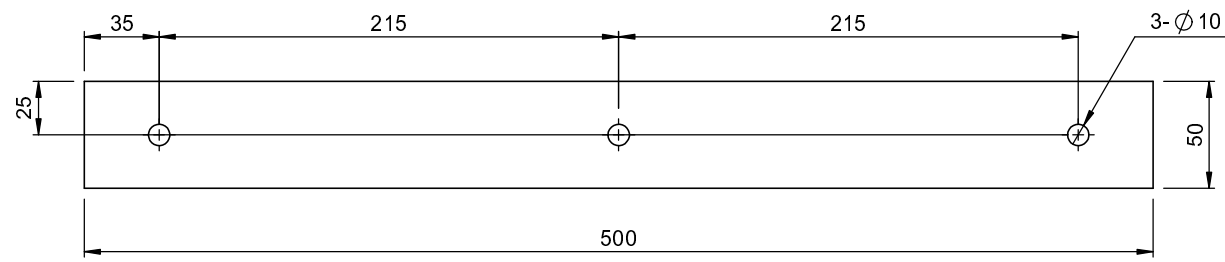

CUSTOMER DRAWING APPROVAL

Customer Reference: _____

Company Name: _____

Signature: _____ Date: _____

Print Name: _____

PRELIMINARY

TOLERANCES - UNLESS STATED OTHERWISE		
UNTOLERANCED DIMENSIONS	+/- 2mm	
CUTTING LENGTHS	+/- 2mm	
FABRICATION	UP TO 300mm	+/- 1mm
	UP TO 1000mm	+/- 2mm
	1001mm & ABOVE	+/- 3mm
	ANGULAR	+/- 1°
MACHINING	+/- 0.2mm	
GAUGE	+/- 10%	
WEIGHT	+/- 10% (DUE TO MATERIAL PROPERTIES & TOLERANCES)	

TITLE: FLAT BAR				P2	13/7/16
DRAWN: G. CRICK				REV	DATE
SIGNATURE: _____				ISSUED FOR APPROVAL	GC
DATE: 13/7/16				DESCRIPTION	DRN
MATERIAL: CARBON STEEL GRADE S275				CHKD	APP
FINISH: NONE					

FINISH NOTE:
PAINT POLYESTER POWDER COAT.
COLOUR: ORANGE (RAL????)

THE COMPANY RETAIN THE RIGHT TO PERIODICALLY ALTER INFORMATION WITHIN THIS DRAWING SHEET AND WILL ATTEMPT TO NOTIFY ALL PARTIES CONCERNED OF ANY CHANGES AND THE INFORMATION ON THIS SHEET SHOULD NOT BE REPRODUCED WITHOUT THEIR WRITTEN CONSENT.

Drw / Stockcode No.	Revision
ZND1043-2-1	P2

1
ALL DIMENSIONS IN MILLIMETRES
REMOVE ALL SHARP EDGES

2
DO NOT JOIN MATERIAL TOGETHER
TO MAKE INDIVIDUAL ITEMS

8
THIRD ANGLE PROJECTION
DO NOT SCALE DRAWING

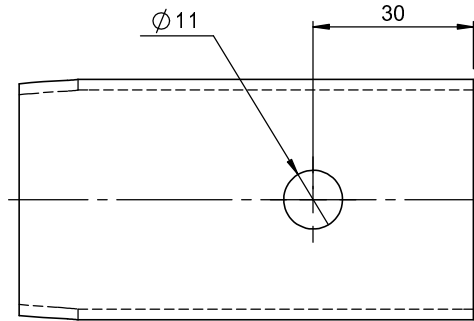
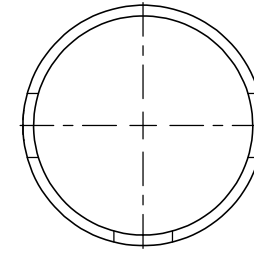
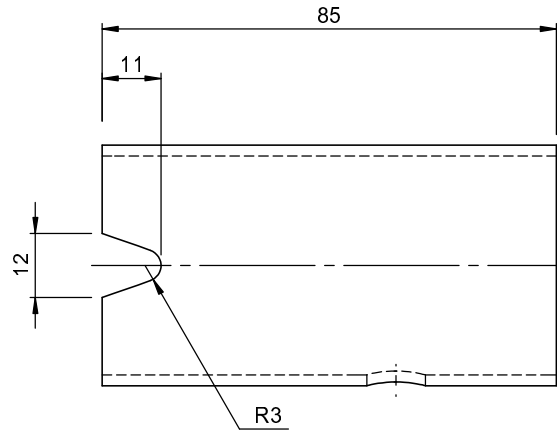

PRELIMINARY

CUSTOMER DRAWING APPROVAL	
Customer Reference:	_____
Company Name:	_____
Signature:	_____ Date: _____
Print Name:	_____

TOLERANCES - UNLESS STATED OTHERWISE	
UNTOLERANCED DIMENSIONS	+/- 2mm
CUTTING LENGTHS	+/- 2mm
FABRICATION	UP TO 300mm +/- 1mm
	UP TO 1000mm +/- 2mm
	1001mm & ABOVE +/- 3mm
ANGULAR	+/- 1°
MACHINING	+/- 0.2mm
GAUGE	+/- 10%
WEIGHT	+/- 10% (DUE TO MATERIAL PROPERTIES & TOLERANCES)

TITLE: SPIGOT TUBE			
REV	DATE	NAME	SIGNATURE
P2	13/7/16	G. CRICK	
MATERIAL: CARBON STEEL GRADE S235		FINISH: NONE	

ISSUED FOR APPROVAL	GC
DESCRIPTION	DRN CHKD APP
Drw / Stockcode No. ZND1043-2-2	Revision P2

THE COMPANY RETAIN THE RIGHT TO PERIODICALLY ALTER INFORMATION WITHIN THIS DRAWING SHEET AND WILL ATTEMPT TO NOTIFY ALL PARTIES CONCERNED OF ANY CHANGES AND THE INFORMATION ON THIS SHEET SHOULD NOT BE REPRODUCED WITHOUT THEIR WRITTEN CONSENT.

1 ALL DIMENSIONS IN MILLIMETRES
REMOVE ALL SHARP EDGES

2 DO NOT JOIN MATERIAL TOGETHER
TO MAKE INDIVIDUAL ITEMS

THIRD ANGLE PROJECTION
DO NOT SCALE DRAWING

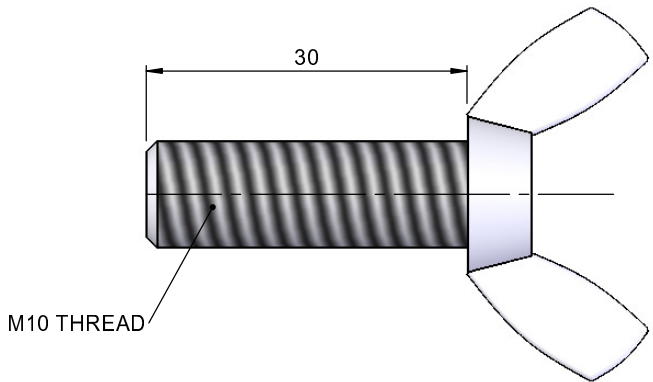

CUSTOMER DRAWING APPROVAL	
Customer Reference:	_____
Company Name:	_____
Signature:	_____ Date: _____
Print Name:	_____

PRELIMINARY

TOLERANCES - UNLESS STATED OTHERWISE		
UNTOLERANCED DIMENSIONS	+/- 2mm	
CUTTING LENGTHS	+/- 2mm	
FABRICATION	UP TO 300mm	+/- 1mm
	UP TO 1000mm	+/- 2mm
	1001mm & ABOVE	+/- 3mm
	ANGULAR	+/- 1°
MACHINING	+/- 0.2mm	
GAUGE	+/- 10%	
WEIGHT	+/- 10% (DUE TO MATERIAL PROPERTIES & TOLERANCES)	

TITLE: M10 WINGED STUD			
REV	DATE	NAME	SIGNATURE
P2	13/7/16	G. CRICK	

ISSUED FOR APPROVAL	GC
DESCRIPTION	DRN CHKD APP

THE COMPANY RETAIN THE RIGHT TO PERIODICALLY ALTER INFORMATION WITHIN THIS DRAWING SHEET AND WILL ATTEMPT TO NOTIFY ALL PARTIES CONCERNED OF ANY CHANGES AND THE INFORMATION ON THIS SHEET SHOULD NOT BE REPRODUCED WITHOUT THEIR WRITTEN CONSENT.

MATERIAL:
**CARBON STEEL
GRADE S235**

FINISH:
ELECTRO GALVANISED

Drw / Stockcode No. **M10 x 30 Lg
WINGED STUD** Revision **P2**