

Circulate to: Sales Manager Accounting Service Manager Technician Parts Manager

Supercharger System Troubleshooting – 135/150/175/200 Verado L4 and 200/225/250/275/300 Verado L6

This service bulletin is intended to guide the technician to properly diagnose Verado supercharger issues. It is also designed to eliminate the unnecessary replacement of a misdiagnosed supercharger, reduce the instances of no trouble found (NTF) supercharger warranty returns, and eliminate the subsequent warranty rejection of serviceable units.

Supercharger Oil Leak

1. Oil observed on top/front of supercharger.
 - **Situation**
 - Oil leakage observed at the top or front of the supercharger below the input pulley.
 - Leak occurs during operation.
 - **Cause**
 - Supercharger input shaft oil seal leak.
 - Porosity or crack in the supercharger end cap.
 - Engine oil leak at the upper crankshaft seal.
 - **Troubleshooting**
 - Clean the oil from the supercharger and engine using a degreaser.
 - Check oil level in the engine. If oil level is above the crosshatched region of the oil dipstick or oil dilution is suspected, perform an oil change filling to the proper level.
 - Remove the air filter and inspect the air intake tube to the throttle body. If oil is present in the tube, clean the air intake thoroughly.
 - Remove the engine flywheel to inspect the upper crankshaft seal. Clean area as needed and install the flywheel.
 - Run the engine for approximately 30 minutes and check for oil leaks.
 - **Correction**
 - Oil leak at supercharger input shaft seal.
 - Install supercharger end cap kit P/N 888947A10 (2005/2006 Verado), P/N 8M0045222 (GEN 1 and newer)
 - Oil leak from porosity in supercharger end cap.
 - Install supercharger end cap kit P/N 888947A10 (2005/2006 Verado), P/N 8M0045222 (GEN 1 and newer)

THE INFORMATION IN THIS DOCUMENT IS CONFIDENTIAL AND PROTECTED BY COPYRIGHT AND IS THE PROPERTY OF MERCURY MARINE.

This document is provided for the sole and exclusive use of the original recipient as prescribed by Mercury Marine and may not be distributed or copied, digitally or otherwise, without the prior written consent of Mercury Marine.

- Engine oil leak at upper crankshaft seal.
 - Replace upper crankshaft seal.
 - If oil was present in the intake tube, the engine may have been past due for an oil change, the oil sump may have been overfull, or the oil separator in the cam cover may be faulty. Any of these conditions can cause oil carryover from the cam cover breather tube resulting in perceived supercharger oil leak. The supercharger should not be replaced under these conditions.

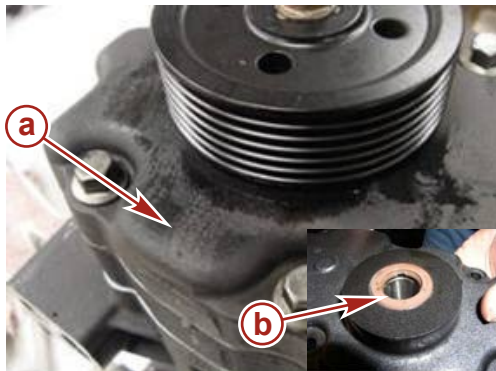

- a - Oil present at top/front of supercharger
- b - Input shaft seal

42667

2. Oil observed on the supercharger bearing housing.

- **Situation**
 - Oil leak observed at the supercharger bearing housing or end plate gasket joints.
 - Oil is observed on the supercharger rotor housing.
 - Leak occurs during operation.
- **Cause**
 - Clamp load of supercharger end cap is low (loose bolts).
 - Excessive oil carryover from the cam cover breather hose.
- **Troubleshooting**
 - Clean the oil from the supercharger and engine using a degreaser.
 - Check oil level in the engine. If oil level is above the crosshatched region of the oil dipstick or oil dilution is suspected, perform an oil change filling to the proper level.
 - Remove the air filter and inspect the air intake tube to the throttle body. If oil is present in the tube, clean the air intake thoroughly.
 - Run the engine for approximately 30 minutes and check for oil leaks.
- **Correction**
 - Oil leak at supercharger bearing housing to end cap joint.
 - Check the clamp load of the end cap bolts. Torque the end cap mounting bolts to specifications following the torque sequence.
 - Install supercharger bushing kit P/N 23-847803A02 (PEEK bushings and gasket).
 - Oil leak at supercharger rotor housing to bearing housing joint.
 - Replace supercharger.
 - Oil leak from porosity in supercharger end cap.
 - Install supercharger end cap kit P/N 888947A10 (2005/2006 Verado), P/N 8M0045222 (GEN 1 and newer)
 - Engine oil leak at upper crankshaft seal.
 - Replace upper crankshaft seal.

THE INFORMATION IN THIS DOCUMENT IS CONFIDENTIAL AND PROTECTED BY COPYRIGHT AND IS THE PROPERTY OF MERCURY MARINE.

This document is provided for the sole and exclusive use of the original recipient as prescribed by Mercury Marine and may not be distributed or copied, digitally or otherwise, without the prior written consent of Mercury Marine.

- If oil was present in the intake tube, the engine may have been past due for an oil change, the oil sump may have been overfull, or the oil separator in the cam cover may be faulty. Any of these conditions can cause oil carryover from the cam cover breather tube resulting in perceived supercharger oil leak. The supercharger should not be replaced under these conditions.

NOTE: Number 1–6 denotes the proper torque sequence.

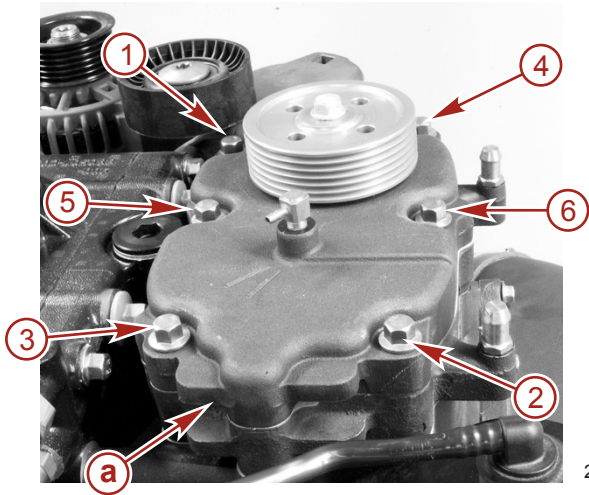

25689

a - Supercharger bearing housing to end cap

Description		Nm	lb-in.	lb-ft
End cap bolts	First	17	150.5	
	Final	35		26

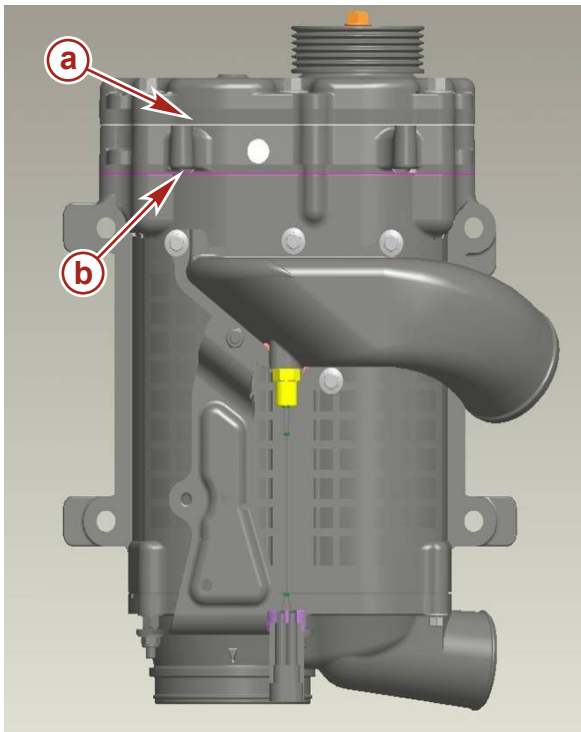

42668

a - Supercharger bearing housing to end cap joint
b - Supercharger rotor housing to bearing housing joint

3. Oil leaking out of the front air vent of the supercharger.

• **Situation**

- Oil leaking out of the front air vent filter of the supercharger.
- Oil is observed on the supercharger rotor housing.

THE INFORMATION IN THIS DOCUMENT IS CONFIDENTIAL AND PROTECTED BY COPYRIGHT AND IS THE PROPERTY OF MERCURY MARINE.

This document is provided for the sole and exclusive use of the original recipient as prescribed by Mercury Marine and may not be distributed or copied, digitally or otherwise, without the prior written consent of Mercury Marine.

- Leak occurs during operation.
- **Cause**
 - Rotor shaft oil seal leak.
 - Excessive oil carryover from the cam cover breather hose.
- **Troubleshooting**
 - Clean the oil from the supercharger and engine using a degreaser.
 - Check oil level in the engine. If oil level is above the crosshatched region of the oil dipstick or oil dilution is suspected, perform an oil change filling to the proper level.
 - Remove the air filter and inspect the air intake tube to the throttle body. If oil is present in the tube, clean the air intake thoroughly.
 - Run the engine for approximately 30 minutes and check for oil leaks.
 - Every 5–10 minutes of running, stop the engine and check or clean the air vent area of the supercharger. A properly operating supercharger should clear residual oil from the vent and stop the leak.
- **Correction**
 - Oil leak continues out of front air vent filter of supercharger.
 - Replace supercharger.
 - If oil was present in the intake tube, the engine may have been past due for an oil change, the oil sump may have been overfull, or the oil separator in the cam cover may be faulty. Any of these conditions can cause oil carryover from the cam cover breather tube resulting in perceived supercharger oil leak. The supercharger should not be replaced under these conditions.

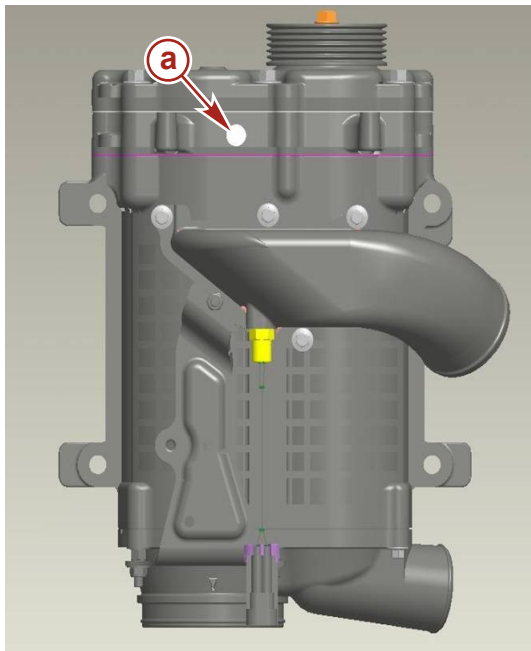

a - Front air vent filter of supercharger

42669

4. Oil observed on rear of supercharger rotor housing.
- **Situation**
 - Oil leaking from the oil supply tubes between the engine crankcase and supercharger.
 - Oil is observed on rear of supercharger rotor housing and/or engine crankcase.
 - Leak occurs during operation or may form drips with the engine turned off.
 - **Cause**
 - Oil supply tube O-rings are missing or damaged.
 - Damaged supercharger mount feet, O-ring grooves, or damaged supply tube fittings.
 - **Troubleshooting**
 - Clean the oil from the supercharger and engine using a degreaser.
 - Run the engine for approximately 30 minutes and check for oil leaks.

THE INFORMATION IN THIS DOCUMENT IS CONFIDENTIAL AND PROTECTED BY COPYRIGHT AND IS THE PROPERTY OF MERCURY MARINE.

This document is provided for the sole and exclusive use of the original recipient as prescribed by Mercury Marine and may not be distributed or copied, digitally or otherwise, without the prior written consent of Mercury Marine.

- **Correction**

- Oil leaking from the oil supply tubes between the engine crankcase and supercharger.
 - Remove supercharger, inspect supply tubes, and O-rings. Replace O-rings and supply tubes as needed.
 - Inspect supercharger mount feet and O-ring grooves for damage. Replace supercharger as required.

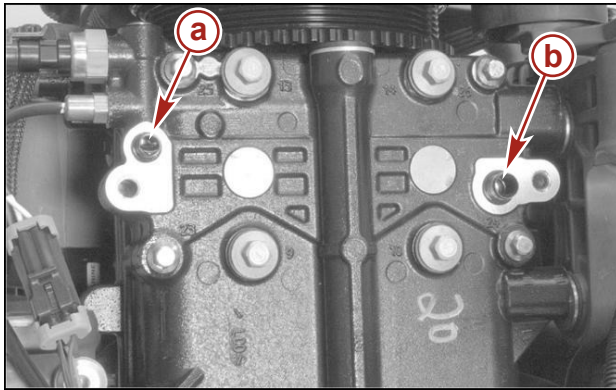

- a** - Oil delivery O-ring and dowel pin (11 mm)
- b** - Oil return O-ring and dowel pin (14 mm)

42670

5. Oil observed on supercharger rotors and outlet duct.

- **Situation**

- Oil observed on supercharger rotors and in outlet duct to charge air cooler (CAC). Supercharger outlet duct housing removed.
- Engine burns oil.
- Engine smokes at start-up.

- **Cause**

- Excessive oil carryover from the cam cover breather hose.
- Bearing housing oil seal damage or leak.
- Excessive crankcase pressure stops oil drain back from supercharger.

- **Troubleshooting**

- Remove the air filter and inspect the air intake tube to the throttle body. If oil is present in the tube, clean the air intake thoroughly.
- Check oil level in the engine. If oil level is above the crosshatched region of the oil dipstick or oil dilution is suspected, perform an oil change filling to the proper level.
- Run the engine for approximately 30 minutes at mid-high range and check for oil leaks.

- **Correction**

- If oil is observed upstream of the supercharger (intake resonator, inlet boot, or inlet duct), the problem is excessive oil carryover from the cam cover breather. The supercharger should not be replaced under these conditions.
- If no oil is observed upstream of the supercharger, remove the supercharger outlet duct and inspect for oil coverage on the rotors and outlet duct to the charge air cooler. If oil is present, replace the supercharger.



42671

THE INFORMATION IN THIS DOCUMENT IS CONFIDENTIAL AND PROTECTED BY COPYRIGHT AND IS THE PROPERTY OF MERCURY MARINE.

This document is provided for the sole and exclusive use of the original recipient as prescribed by Mercury Marine and may not be distributed or copied, digitally or otherwise, without the prior written consent of Mercury Marine.