

CRAMARO®

TARPAULIN SYSTEMS

LIFT 'N GO™

**INSTALLATION, MAINTENANCE,
& SAFETY INSTRUCTIONS**

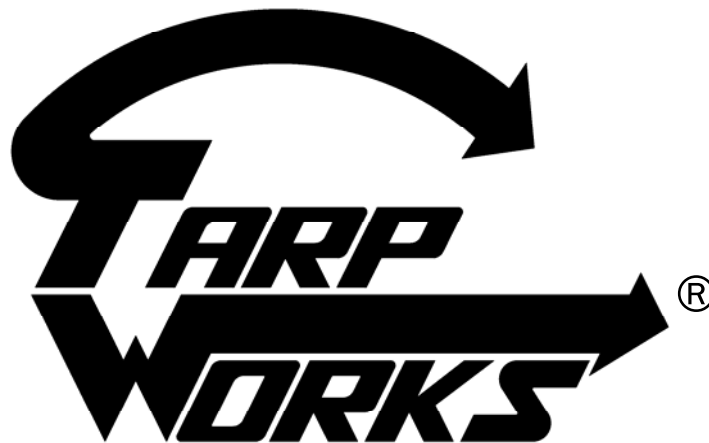

(800) 272-6276

001-321-757-7611

www.cramarotarps.com

Plants In: Delaware, Florida, Massachusetts, Nevada, Ohio, and Canada

Before You Start

Cramaro understands the value of installation time. Therefore we have preassembled our Lift N' Go for your convenience. The system has been pre-plumbed, the cylinders have been bled to remove air and the four-button switch has been pre-wired.

The following instructions have been prepared for a regular installation. Due to the variety of trucks, adequate clearance may not be available and additional adjustments or modifications may be required.

The clearance between the back of the truck cab and the front of the container must be at least 14" this is to allow for a proper installation of the tower. The front of the lower telescoping tube of the gantry should be between 4 1/2" and 5" from the back of the cab.

It is important to check for other truck components that might interfere with the installation. Engine exhaust and hook-up lines are examples that might have to be rerouted.

The tower should be mounted to the frame using the U-Bolt Kit that is sold separately. If the U-Bolt kit is not to be used or is not desirable then one option is to attached angles to the frame and then mount the tower using holes that can be drilled in the angles.

Never weld onto or drill into your vehicle's frame. It could cause permanent damage and possible injury. Only certified technicians are allowed to modify the frame.

This installation manual has many steps but it is divided into two main parts. Installing the tower and installing the Flip N' Go or SRG arms.

Step 1: Switch Bracket

Prior to mounting the tower to the frame attach the four button switch brackets to the gantry with the XXX bolts provided.

Step 2a: Installing the Tower— U-Bolt Kit

1. Locate the U-Bolt Kit
2. Position the tower on the frame rails allowing at least 4 1/2" to 5" from the back of the cab to the lower part of the tower. Make sure that tower operation will not interfere with other truck components.
3. Square the tower to the frame rails.
4. Slide the U bolts around the frame and through the predrilled holes in the tower bases and bolt into place using nuts provided.

Step 2b: Installing the Tower— Angle Brackets

1. An alternative to the U-Bolt Kit is to install mounting brackets to the frame and then drill mounting holes into the brackets.
2. Large pieces of steel angle can be bolted to the sides of the frame or to a cross member. When using this option make sure you use existing holes in the frame.
3. If holes are not available then the brackets made from steel angle could be welded on or have holes drilled in the frame. This option **MUST** be done by a certified technician otherwise permanent damage could occur resulting in an unsafe frame condition.
4. The angle bracket should be mounted with vertical side being mounted to the frame. The other side of the angle will serve as a horizontal mounting surface

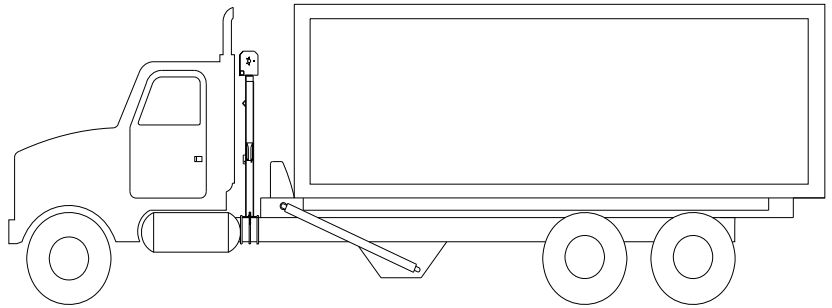

Step 3: Install the Header

If you have ordered an accompanying flip system along with your tower, the header assembly will come with the roller extrusion and other items preinstalled for your convenience.

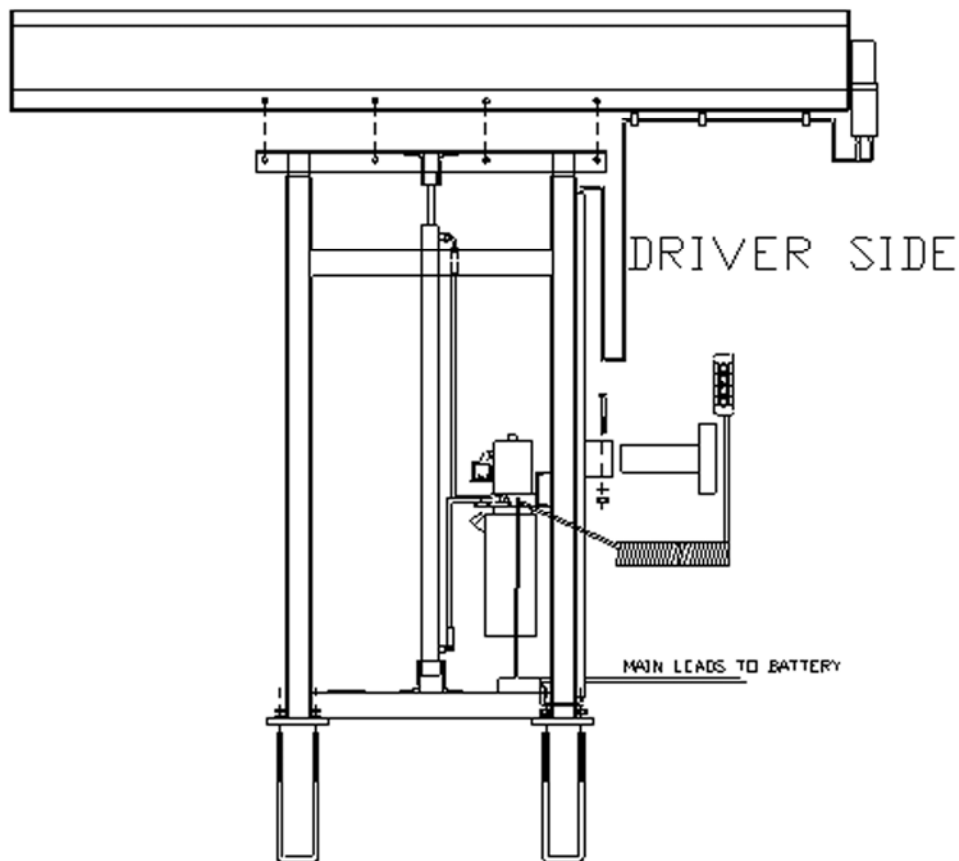

Step 4: Wiring

Wire main leads from tower to truck battery using the double 40Amp breaker on the positive lead. The wire may need to be shortened if it is too long.

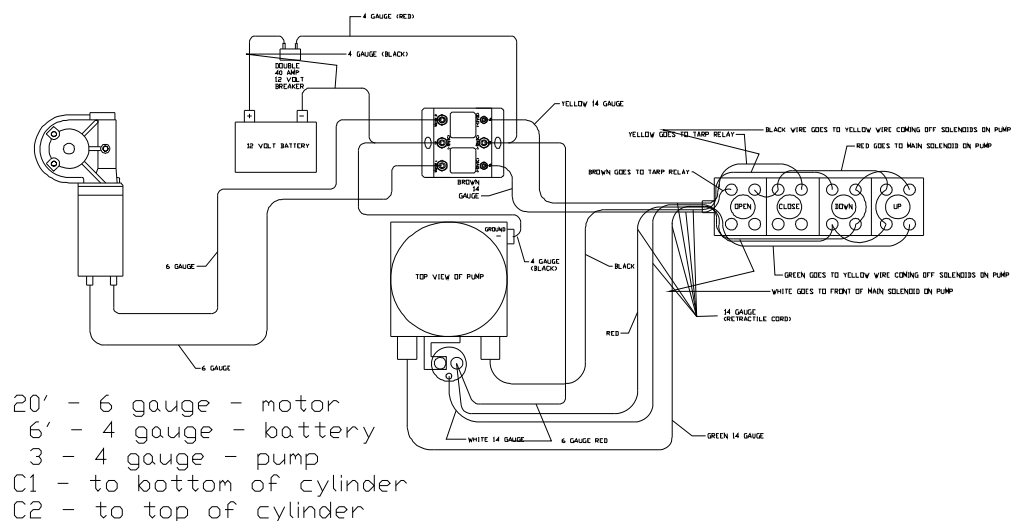

Step 5: Installing the Pivot Point—Overview

1. Before you begin we recommend that you load your largest or most frequently used container, and that you have the tower in its lowest position or in the fixed position where it will be mostly used.
2. If you will haul different containers then be sure to check ALL sizes for adequate clearances.
3. The final position pivot is very dependant on what is available to mount the pivot to.
4. The pivot point for the arms is a spot that is the same distance from the point that the tarp exits the header to the back of the container where it stop when closed. It should be as low as the frame and not in a position to interfere with the lift cylinders or other mechanisms. This will allow the arms to swing equally from front to back..
5. Double check the spot by measuring the pivot point to the back of the trailer. It should be the same as the distance from the pivot point to where the tarp leaves the header assembly.

Step 6a: Installing the Pivot Point—Without a Mounting Kit

1. You can mount the pivot point directly to the vehicle if there is something to mount it to; at or below frame level. An example would be heavy steel fenders made from diamond plate or side compartments that are strong enough to hold the flip arms.
2. Determine the pivot point. That is the spot at or about frame level that is the same distance from the trailer header and the stopping point at the rear of the vehicle. It would look like an upside down triangle with two (2) equals sides and the point at the bottom of the triangle being the pivot point.. Bolt or weld the base of the pivot piece to the measured pivot point..
3. Double check your measurements and repeat the installation on the other side.
4. Finish the installation by following the instructions in the install manual that comes with the flip system purchased.

Step 6b: Installing the Pivot Point — Telescoping Pivot Mount Kit

1. The Telescoping Pivot Mount Kit can be used to create a robust base to attach the pivot point to.
2. The kit consist of: 2 outer telescoping section with a mounting plate attached, 2 inner telescoping pieces without a plate, and 2 mounting plates that can be welded to the inner piece, a total of 6 pieces.
3. Attach the section with the pre-welded plate onto the vehicle's frame. It can be either bolted, using exiting holes, or welded by a certified welder.
4. If necessary orientate the plate to vertical position and weld it onto the inner telescoping piece. This will allow for any corrections required to correct hole placement issues when the outer telescoping piece was attached to the frame.
5. Slide the telescoping pieces together until the desired clearance is obtained. Remember the 108" maximum allowed vehicle width and the need for the arms that will be mounted on the pivot points to clear the container.
6. Once the correct potion is obtained bolt or weld the inner and outer pieces together to form a permanent mounting surface.
7. Repeat this in the same position on the other side of the vehicle.
8. Finish the installation by following the instructions in the install manual that comes with the flip system purchased.

Step 6c: Installing the Pivot Point — Tandem Axle Mount Kit

1. The Tandem Axle kit uses the same telescoping pieces as the Telescoping Mounting Kit except each side has 2 telescoping pieces for each side of the vehicle and a single piece of steel angle instead of plates.
2. Locate the pivot point then mount (by welding them or bolting them to the frame) two of the telescoping bases far enough apart to clear any obstructions such as going around a tire.
3. Joint the two telescoping pieces by welding or bolting the steel angle to both inner (sliding) telescoping pieces (The ones with out the flange attached).
4. Slide the telescoping pieces together until the desired clearance is obtained. Remember the 108" maximum allowed vehicle width and the need for the arms that will be mounted on the pivot points to clear the container.
5. Once the correct potion is obtained bolt or weld the inner and outer pieces together to form a permanent mounting surface.
6. Double check the pivot point and bolt or mount the pivot the mounting kit. The centerline of the shaft on the pivot should be where the pivot point is.
7. Double check measurements and repeat for the other side.
8. Finish the installation by following the instructions in the install manual that comes with the flip system purchased.