

Vulcan Corvair Enthusiasts, a chapter of the Corvair Society of America, is a non-profit club dedicated to the preservation and restoration of the Corvair automobile.

VCE dues of \$20/year pay for a family membership and 12 issues of the *Oil Drop* newsletter.

President: Ed Keller
205/823-5424

Vice President: Harold Hartline
205/491-5253

VP/Membership/Newsletter: Russell Noble
205/822-6092

Secretary: Joe Doughty
205/853-0434

Treasurer: John Hathaway
205/408-4063

Hospitality: Jon & Sarah Keeton

CEO of Enforcement: Jewel Hinkle

Web: <http://clubs.hemmings.com/vulcancorvair/>



Walt Davison on the move in his UltraVan somewhere in CA



Vulcan Corvair Enthusiasts
PO Box 59071
Birmingham, AL 35259-9071



T
H
E

OIL DROP

THE OFFICIAL NEWSLETTER OF THE VULCAN CORVAIR ENTHUSIASTS Vol 22, No 1

January 2001

From the Prez

Well, sports fans, another year has come and gone, and it looks like you're stuck with the same old crew. We will just have to make the most of it.

Some of the dates for this year's events and shows are beginning to be announced. I will try to keep the calendar of events up to date. The first thing up is the mid-winter retreat in Pigeon Forge Jan. 19-21. Last year it snowed all day Sat. and really put a crimp in the shopping for the ladies. Maybe we will have better weather this year. Try to make the trip to Navarre Beach in February. We had a good turnout last year, and this is always a relaxed, fun time. In May, there will be an AACA National show at Talladega. If you have not seen one of those, you have really missed something. Probably, there will be 300-400 cars of the highest restoration standards. Since this month's meeting will be on Friday, Jan. 19th, Russell Noble will have to fill in, as some of us will be gone to Pigeon Forge.

Till next time,
Ed

Next Meeting:

Date: Friday, January 19th, 2001

Time: 7:00 PM

Place: Vestavia Hills Library on Hwy 31

Supper is going to be a surprise meal put on by Jewel Hinkle and Rozelle Doughty. Don't miss it, as I'm sure it will be good. See you there!

Calendar of Events

- Jan 19-21 Mid Winter Corvair Retreat - Pigeon Forge, TN
- Feb 9-10 Corvair Lover's Holiday - Navarre Beach, FL
- Mar 2-4 Spring Warm-up - Myrtle Beach, FL
- Apr 5-8 Charlotte Auto Fair - Charlotte Motor Speedway, NC
- Apr 7 Annual Mobile Camilla Classic Car Show - Bellingrath Gardens
- Apr 21 Enterprise, AL Car and Truck show
- May 4-6 Virginia Vair Fair - Hampton, VA
- May 5 AACA Southeastern Division National Spring Meet - Talladega, AL
- May 18-20 Annual Vair Pilgrimage @ Charleston, SC
- Jul 25-28 CORSA International Convention - Chicago, IL

Thanks

Joe and Rozelle Doughty hosted the VCE Christmas party at there new home last month. Thanks for the hospitality Joe and Roz!

--- DUES are DUE --- DUES are DUE ---

A Note...

To the greatest group in the world-----
My Corvair Friends,

I want to thank everyone of you from the bottom of my heart for the outpouring of love and friendship from all of you, as made evident by all the cards, phone calls, email and visits to me both at the hospital and to my home. The fruit basket sent to me by the club was and still is most enjoyable and most appreciated.

I don't express my feelings as well as I would like, but one thing I really want to get across is how much you all have helped me to get thru this problem. Your support has helped me to push forward with the things I have to do to return to a healthy state.

I really am sorry to miss the Christmas party and to see the Doughty's new home. I feel sure I will make the January Meeting.

Love to All
Bob Siemens

Mail Bag: A Plug for the Vair Fair

Seasons Greetings!

It is the season when most of us are under our Corvairs doing maintenance, repairs and upgrades to make them the reliable, roadworthy classic automobiles they are. It is also the time to start thinking about the Corvair events that are coming up in 2001. We here in Tidewater Virginia have an annual event that you or your club members may have attended before called the Virginia Vair Fair. This is the 22nd year and this event continues to be a well-attended fun event. Through out the years it has been typical to draw Corvair enthusiasts from Virginia, North and South Carolina, Maryland, Pennsylvania, Ohio, Delaware, Tennessee, Georgia, Florida, New Jersey, and West Virginia. We hope this year will be no exception and even expect several new faces and new vehicles. Tidewater Corvair Club is hosting the event this year and we are planning an aggressive schedule. We hope that you will be able to join us on May 4th through the 6th at Fort Monroe, Virginia. The host hotel, the Chamberlin is a magnificent 1800's hotel on a historic US Army Base. We negotiated a special price for this event hoping to make it affordable for all. On the Base is Old Point Comfort Lighthouse and the Casemate Museum as well as the US's largest stone fort guarding the Chesapeake Bay. We have mailed an information package to your club address and

also set up a web site where the registration forms and schedule can be downloaded.

<http://tidewatercorvairs.tripod.com/vairfair/>

Thank you, we hope to see you in May 2001.

Tidewater Corvair Club, Inc.
Corvair@hamptonroads.com
Dan Jones, Pres. (757) 838-2322

******* VCE Classifieds *******

We will continue to run for sale and wanted ads until we are notified to remove the ad (unless the space is needed for articles or new item), so let us know!

For Sale

1965 Monza 4-door hard top. 51,000 actual miles. Excellent rust free body. Extra nice original interior. 140 engine. Restoration started - also parts car included. All for \$1000 or best offer. For details call Jerry Smith (205) 640-6952.

For Sale

1964 Monza convertible. Recent saddle bronze paint and white top. New WSW tires, wire caps, good brakes. Floorboards have been cleaned, rustproofed, and primed. Underside cleaned and painted. Runs good. Was original factory air car. Have all parts to restore A/C. Needs new interior. \$3,400 OBO. Ed Keller (205) 823-5424

A Good Story

Check out the article about Charles Trotter's contributions to his community on the next page. Congratulations, Charles!

Dues are Due

Charles Trotter Day proclaimed in Pell City

Rotary Club honors Pell Citian who has 'given so much to community'

By **David Atchison**
Home staff writer

The Rotary Club of Pell City had a special salute luncheon for Charles Trotter Tuesday because Rotarians say he has given so much of himself to the community in which he lives.

"Today we are here to honor one of our own, Charles Trotter," said Joe Allinder, Rotary president.

Trotter, an honorary member of the local Rotary Club, was surprised that he was the guest of honor.

"Charles thought we were coming to a Christmas party," said his wife, Jan. "All I've got to say is, what a party."

Guest after guest thanked Trotter for the helping hand he offers to organizations in need, organizations that help the people, and even the animals, of the community.

The event was an emotional thank you, Allinder said. Because of Trotter, the Rotary Club now has a second scholarship award for a Pell City High School student.

"Charles has been gracious to the Rotary Club," Allinder said.

There were friends and representatives from a variety of organiza-

tions the Trotters have helped personally and financially throughout the years.

"None has done any more for the community than the gentleman we're honoring today, and that gentleman is Charles Trotter," Mayor Guin Robinson said. "Every worthwhile organization that needed help, Charles Trotter was there."

Robinson said everyone who was invited to the luncheon attended, which speaks highly of Trotter.

Robinson and the Pell City Council proclaimed Tuesday, Dec. 12, 2000, as Charles Trotter Day. Robinson presented Trotter with a key to the city and a paperweight with the city seal.

Trotter not only helps an array of organizations in Pell City and St. Clair County, but he has crossed the river into Talladega to lend a helping hand.

In one emotional thank you, and there were many, Lottie Haynes, a representative of the Talladega Animal Shelter, told about Trotter coming to her shelter and seeing holes in the roof and walls. The door to the shelter had fallen off its hinges, she said.

It was Trotter, Haynes said, who was instrumental in getting the shelter back in order. In tears, she handed Trotter the shelter's award of recognition.

Trotter has not only helped the animal shelter there, he is one of the largest contributors to the animal shelter in Pell City.

"Thank you for what you do for us and the entire community," said Pat Tucker, a board member of the Pell City Animal Shelter.

Trotter has regularly donated time and made large contributions to organizations including the United Way, the Children's Place, the Pell City Educational Foundation, Lakeside Hospice, Camp ASCCA for handicapped adults and children, the Bridge Builders, Habitat for Humanity, the local Boys Scouts, the Pell City Library and the Library Guild, the local chapter of the Daughters of the American Revolution, among other organizations.

"He has touched many people," said Dave Clark, a member of the Pell City Habitat for Humanity, an organization that builds homes for those in need.

Clark recalled building Habitat's second house in Pell City, wondering where they were going to get money to finish what they had started.



David Atchison/The Daily Home

The Rotary Club of Pell City held a special salute to Charles Trotter for all he has done for the community.

"We were doing a little bit on faith," he said. "Out of the blue, a check from Charles Trotter enabled us to finish the project. He's always there when you need help the most, just at the right time."

Two flags were presented to

Trotter at the luncheon. One of the flags was flown at the Capitol in Washington, D.C., Nov. 28 in honor of Trotter, and the other flag was flown at the state Capitol in his honor.

"Thank you for all of your contributions," Robinson summed up. "I think what we're all trying to tell you is that we love you and appreciate you. We appreciate both of you."

Vulcan Corvair Enthusiasts, a chapter of the Corvair Society of America, is a non-profit club dedicated to the preservation and restoration of the Corvair automobile.

VCE dues of \$20/year pay for a family membership and 12 issues of the *Oil Drop* newsletter.

President: Ed Keller
205/823-5424

Vice President: Harold Hartline
205/491-5253

VP/Membership/Newsletter: Russell Noble
205/822-6092

Secretary: Joe Doughty
205/995-0131

Treasurer: John Hathaway
205/408-4063

Hospitality: Jon & Sarah Keeton

CEO of Enforcement: Jewel Hinkle

Web: <http://clubs.hemmings.com/vulcancorvair/>



Just Another Hoppin' Time at a VCE Meeting!



Vulcan Corvair Enthusiasts
PO Box 59071
Birmingham, AL 35259-9071



T
H
E

OIL DROP

THE OFFICIAL NEWSLETTER OF THE VULCAN CORVAIR ENTHUSIASTS Vol 22, No 2

February 2001

From the Prez

By the time this newsletter is out, we will probably be at the Navarre Beach shindig put on each year by the West Florida Corvaire group. Hope most of you can make it.

Our best wishes and thoughts go out to Grant and Mary Snead while Grant is recovering from his recent surgery.

I have added the date for the annual show at Helen, GA to the calendar, as well as some other dates which have been announced. See you at the meeting - Feb 16th - Library.

Ed

Next Meeting:

Date: Friday, February 16th, 2001

Time: 7:00 PM

Place: Vestavia Hills Library on Hwy 31

Harold and Louise Hartline will be serving dinner for the meeting in February. If it is anything like the ham the Hartline's brought last November, it will be dynamite. Don't miss it!

Calendar of Events

- Feb 9-10 Corvaire Lover's Holiday - Navarre Beach, FL
- Mar ? BBQ Run - To be announced later
- Mar 2-4 Spring Warm-up - Myrtle Beach, FL
- Apr 5-8 Charlotte Auto Fair - Charlotte Motor Speedway, NC
- Apr 7 Annual Mobile Camellia Classic Car Show - Bellingrath Gardens
- Apr 21 Enterprise, AL Car and Truck show
- Apr 24-29 Helen, GA Springfest
- May 4-6 Virginia Vair Fair - Hampton, VA
- May 5 AACA Southeastern Division National Spring Meet - Talladega, AL
- May 18-20 Annual Vair Pilgrimage @ Charleston, SC
- Jul 25-28 CORSA International Convention - Chicago, IL
- Sept 29 Wings and Wheels Car Show - Bessemer Airport

Pigeon Forge Report

It was a "dark and stormy" morning when the Hartlines with John Hathaway in tow met the Kellers on Hwy 79 headed towards Guntersville. There we picked up the Siemens and headed north - the ladies in one minivan, the gentlemen in another (We had things to talk about - where to shop, what to shop for.) I'm sure the guys had a lively conversation as well - we didn't ask. (Cont.)

--- DUES are DUE --- DUES are DUE ---

Pigeon Forge Report (cont.)

The weather Friday was terrible, but with a promise of snow, Corvair friends to see, we looked forward to the trip. The snow came in big flakes on Saturday, (didn't curtail the shopping), friends came from Tenn., the Carolinas, Virginia, Georgia, and Alabama. We had several good meals at local restaurants plus the NC and Tenn. clubs always have a nice hospitality spread. The ladies shopped, the men talked, and we all ate. A good time was had by all. - Carol Keller

January 2001 VCE Meeting Minutes

The Meeting was held at 7PM at the Vestavia Library with Jewel Hinkle and Rozelle Doughty serving a delicious meal after which Russell Noble, substituting for Pres. Ed Keller, called the business meeting to order.

There was no treasurer's report since John Hathaway, our Treasurer, was in Pigeon Forge attending the "Mid-winter Corvair Retreat" along with the Kellers, Hartlines, and Siemens.

A motion was made, and seconded and unanimously approved by members present to donate \$100 to the Vestavia Library for having allowed our club to hold our meetings there during the year 2000.

Russell Noble stated that the library had extended permission for us to hold our monthly meetings there throughout the year 2001.

Russell Noble announced the upcoming Corvair Lovers' Holiday at Navarre Beach, FL on Feb 9-10, 2001.

Russell Noble, the Editor and Publisher of the Oil Drop, encouraged members that have cars or parts for sale to give him the information and he will publish an ad in the Oil Drop to run until he is told to drop it or until space is needed for other articles.

David Langner stated that he has a 1963 convertible parts car and anyone needing convertible parts can give him a call.

Walt Davison conducted a short tech session on carburetors stressing the need to make sure the idle jets were unclogged during the cleaning process.

There being no further business the meeting was adjourned.

Joe Doughty
Secretary

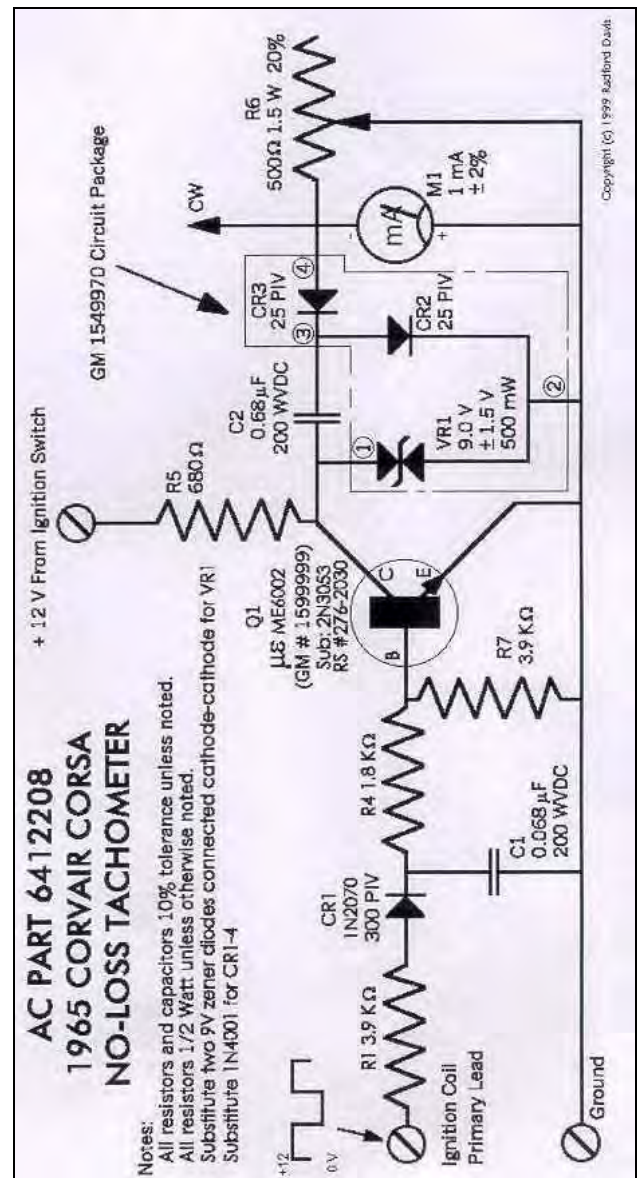

***** VCE Classifieds *****

For Sale

1964 Monza convertible Recent saddle bronze paint and white top. New WSW tires, wire caps, good brakes. Floorboards have been cleaned, rustproofed, and primed. Underside cleaned and painted. Runs good. Was original factory air car. Have all parts to restore A/C. Needs new interior. \$3,400 OBO. Ed Keller (205) 823-5424

Parts Wanted

Late model parts (1965): good front seats, turbo heat shield, air cleaner lid (turbo), turbo muffler bracket, turbo right heater hose sheet metal, heavy duty pressure plate, 'Corsa' fender emblem, jack, alternator, trunk lock cylinder and retainer, 'Corvair' deck emblem, bottom cove trim, rear convertible weights. Call David Langner, 298-3531 at work or 655-9445 at home or 676-5632 on his pager.

Interesting Article on Reformulated Gasoline by Brent Covey via *The Corvair Center's "Forum"*

10/9/00

Hi everyone-

The posting below about the gas tank sealants got me thinking I should remind people about the other aspects related to reformulated fuels-

I understand the entire US is currently using reformulated gasoline now, there's a few different blends and proportions of oxygenates used in different areas, from very little in most places to 14% MTBE content in California. The refiners have a couple different chemicals they can use for oxygenates but MTBE is the most common. In Canada MTBE is never used however most of the MTBE used in the western US is made by a Canadian company, its manufactured from natural gas.

All of these chemicals have common characteristics, to be an oxygenate, they have to create a chemical reaction during combustion that helps oxidize the fuel molecules and help them burn completely. This means they contain oxygen compounds that are liberated when they burn.

The downside of this is fuels containing oxygenates will oxidize everything they touch or come in contact with- rust is iron oxide for example- and things like rubber fuel line hoses and most materials will be affected from this oxidization. This is a problem; fuel line hoses are only considered safe for 3 years max by the current SAE spec. People have to be very careful to inspect and routinely replace rubber gas line and filler pipe hoses and watch out on the big tank sender O-ring etc for premature deterioration. This kind of stuff used to quite reliably last 10-20 years on older fuels but those days are gone. We will not be getting the same service out of fuel pumps and carb seals we once did either. Usually most seal materials will swell and soften on the new gasolines, but very old straight neoprene hoses just shrink and crack.

Another attribute of oxygenated fuels is that the compounds used as oxygenates all attract water very strongly. MTBE is rapidly becoming famous on this score, as it likes to permeate drinking water supplies and isn't broken down in the environment well, which gasoline and alcohols are. In your car, this means gas tanks are more apt to pick up water, whether in the car or at the filling station- and as the fuel evaporates, you'll be left with more water than the gasoline can hold and have water contamination problems. Water in the carbs will be more common than ever, so watch for it if your car starts running poorly for no real reason.

You'll also find the new fuels leave a very persistent deposit if allowed to dry out. I'd make a point of running a car right out of fuel before long term storage, to minimize problems in this department.

The good news is the new gas has so much detergent that carbs get cleaner as you drive now; -) Oxygenates are also very good octane enhancing compounds and will boost octane in even small amounts.

Oxygenates do contain significantly less thermal energy than gasoline, and especially less than compounds like benzene and toluene that used to be in gasolines in large amounts. What this means is depending on the content used in your fuel, the gas is 'weaker'. A gallon of California gasoline is only 85% gas now, most of the remainder is MTBE. Because MTBE doesn't have the explosive energy of gasoline, you'll need to burn more fuel for the same performance. You won't need 15% more, but you will need somewhat more than the car is jetted to provide. Cars with carburetors and fixed metering systems like early FI with no oxygen sensors will need mixture strengths strengthened to work like they're designed to on the reformulated fuels. In general terms most older GM cars need a main jet about 3 sizes richer to retain the original performance levels. In places like California that are largely low altitude and very hot and have very weak fuels, even greater changes may be needed.

I've been seeing a lot of older GM cars with QuadraJets in CA flunking emissions inspections because they've leaned out so far the carbs need significant changes to have clean exhaust. If you have a car that has persistent high HC emissions on inspections (anything over 100ppm is pretty high) you might explore a richer main jet and or opening up idle limiter provisions in your carb. Corvair engines, particularly 1965-'67 95 and 110 HP are extraordinarily clean on smog tests if everything's working well. Most 1965-'69 Corvair engines could pass a 1981 new car standard if tuned to a fare thee well.

Anyhow, the message is- you can expect fuel system leaks to be a regular problem now, and you'll need to spend a lot more effort on maintaining perishable fuel system components than you are used to. You also may have to recalibrate the carbs a little to make the car run well and efficiently, and to pass smog testing you may have to make further changes.

One last thing- it is worthwhile if you are parking cars to park on a surface that a fuel leak can be absorbed into. Unpainted concrete or gravel is much safer than a shiny or blacktop surface if a leak develops. You want to gas to soak away where it can't ignite hopefully. When working on fuel system parts make sure you park with the cars nose pointed downhill too, so gravity doesn't allow it to leak from disconnected parts. And last of all, NEVER use an electric light when working on a gas tank or in areas where fuel could even have a remote chance of splashing. Use a mirror or piece of cardboard covered in tinfoil etc to reflect light where you need it. Hope this is interesting, *Brent*

Vulcan Corvair Enthusiasts, a chapter of the Corvair Society of America, is a non-profit club dedicated to the preservation and restoration of the Corvair automobile.

VCE dues of \$20/year pay for a family membership and 12 issues of the *Oil Drop* newsletter.

President: Ed Keller
205/823-5424

Vice President: Harold Hartline
205/491-5253

VP/Membership/Newsletter: Russell Noble
205/822-6092

Secretary: Joe Doughty
205/995-0131

Treasurer: John Hathaway
205/408-4063

Hospitality: Jon & Sarah Keeton
CEO of Enforcement: Jewel Hinkle

Web: <http://clubs.hemmings.com/vulcancorvair/>



Frank Ranelli's 1966 Late Model Coupe



Vulcan Corvair Enthusiasts
PO Box 59071
Birmingham, AL 35259-9071



T
H
E

OIL DROP

THE OFFICIAL NEWSLETTER OF THE VULCAN CORVAIR ENTHUSIASTS Vol 22, No 3

March *2001*

From the Prez

Navarre Beach Report

February 9th, 7:30 sharp, five couples met at the Cracker Barrel on 119. The Siemens got up at o'dark thirty to arrive from Guntersville at the designated meeting place. The Hinkles and Hartlines came from the west and the Doughtys and Kellers came from south of B'ham eager to head to the beach. Harold Hartline was our leader and set a lively pace (he was flying) with no stops til we were south of Montgomery - a 'rest stop' never looked so good. We made good time the rest of the way and were at the bridge to Navarre by lunchtime. Lunch was seafood at 'Trader Joes' by the bridge. It was warm, it was Friday, and the sun was out, so nothing could have been better. The rest of Friday was spent greeting friends, watching the sea birds, and cooking (Harold cooked up a crockpot of wonderful stew to add to the hospitality dinner put on by the West Florida Club). Mickey and Robin Hunter along with Brannon and Holly came down from Decatur. Owen and Joyce Miller were already there at the Holiday Inn when we arrived as well as Hugh and Sara White (VCE members). Mike Donley joined us on Friday evening from Montgomery. Vulcan Corvairst Enthusiasts Club

was well represented. Harold Hartline displayed his car, and Ed Keller entered his car in the show, all to support the West Florida Club. Ed came away with a second place trophy. The West Florida Club put on a great show as always. The Hartline grandchildren seemed to have a good time with Brannon's finding prize parts for his car from the vendors and Holly's keeping everyone entertained.

Ed

Next Meeting:

Date: Friday, March 16th, 2001

Time: 7:00 PM

Place: Vestavia Hills Library on Hwy 31

Ed and Carol Keller will be serving dinner for the March meeting. No word on the menu, but I'm sure you don't want to miss it. Maybe the weather will cooperate this time!

Dues Notice:

Your year 2001 club dues should now be paid up. (This does not apply to several members that do not pay on a Jan-Jan interval) If not, bring your \$20 to the meeting or mail the funds to:

John Hathaway
1406 highland Lakes Trail
Birmingham, AL 35242

--- DUES are DUE --- DUES are DUE ---

Calendar of Events

- Apr 5-8 Charlotte Auto Fair - Charlotte Motor Speedway, NC
- Apr 7 Annual Mobile Camellia Classic Car Show - Bellingrath Gardens
- Apr 21 Car Show & Picnic - Lunch & Music@ "Old Town" - Helena
- Apr 21 Enterprise, AL Car and Truck show
- Apr 27-29 Helen, GA Springfest
- May 4-6 Virginia Vair Fair - Hampton, VA
- May 5 AACA Southeastern Division National Spring Meet - Talladega, AL
- May 12 Sports Cars at Tannehill
- May 18-20 Annual Vair Pilgrimage @ Charleston, SC
- Jul 25-28 CORSA International Convention - Chicago, IL
- Sept 15 Tour to Millard Young's - Piedmont, AL
- Sept 29 Wings and Wheels Car Show - Bessemer Airport

February Meeting "Stormed Out"

The terrible storm Friday afternoon on Feb 16th left many in the area without power - including the library in Vestavia. The Hartlines' power went out while they were cooking dinner for the meeting. So they moved the food to the Hinkles (that had power) to finish. Well, the meeting got canceled and guess what? The Kellers found out about the meal and drove over to the Hinkles. The Siemens were in town staying at the Hartlines; so what we have here is four couples and a *ton* of red beans and rice. Needless to say, it was a pig-out. Thanks to those that stayed on the phone to get the cancellation word out to VCE.

Visit to Southwest Corvair Salvage

I happened to be out in Phoenix, AZ on business a couple of weeks ago and had a free afternoon to roam around a bit. I decided to go by and pay Mark Aksamit and Southwest Corvair a visit. I had bought a few parts from Mark in the past and wanted to see the guy in person and check out his stash.

I let Ed Keller know I was heading out to AZ, so he asked if I would look for a ramp, electric top parts and some other hard to find goodies. So, now I had a mission. I gathered the address and some computer generated detail maps. The place was sort of downtown, across the dry Salt River.

I had to make a few passes down the street it was supposed to be on...pretty strange. A trailer here,

frame house there, junkyard next door (no Vairs), abandoned house, etc. You get the picture, no zoning here. Well I couldn't find it so I found a phone and called. Mark said I must have drove right past it. "Look for the 140 on the mailbox," he said. Sure.

I found the place. A small white frame house (no sign) with an 8-foot fence around the yard with double garage doors bolted to the fence so you can't see through...hmmm.

I went inside the deserted house and yelled. Mark came out. (Sorry Ed, no ramp or other stuff on the list...pretty rare he says.) We chatted a little while - nice guy. I then asked if I could look around.

We headed out back and I am expecting to see rows and stacks of Corvairs. Nope. I saw only two cars. "Where's all your parts cars?" I said. Mark replied, "I don't run a junkyard, I run a parts business." Wow, this guy is serious. The whole 'yard' was about 100'x150' with a couple of trailers to organize stuff. Sheet metal was hung on the fence. There were two guys hammering on a front crossmember, and that was about it. I guess good things do sometimes come in small packages.

Russell Noble

******** VCE Classifieds ********

For Sale

1964 Monza convertible Recent saddle bronze paint and white top. New WSW tires, wire caps, good brakes. Floorboards have been cleaned, rustproofed, and primed. Underside cleaned and painted. Runs good. Was original factory air car. Have all parts to restore A/C. Needs new interior. \$3,400 OBO. Ed Keller (205) 823-5424

For Sale

1964 Monza Coupe 4-speed, 66,500 miles, light tan, dark tan interior, 2nd owner, B'ham car, new tires, stored inside 10yrs, \$1400. Call Roy Laughlin 681-6856.

Parts Wanted

Late model parts (1965): good front seats, turbo heat shield, air cleaner lid (turbo), turbo muffler bracket, turbo right heater hose sheet metal, heavy duty pressure plate, 'Corsa' fender emblem, jack, alternator, trunk lock cylinder and retainer, 'Corvair' deck emblem, bottom cove trim, rear convertible weights. Call David Langner, 298-3531 (work) or 655-9445 (home) or 676-5632 on his pager.

Wise is what he drives

Saturday February 10, 2001

By The Associated Press

Beneath a near cloudless sky on a 70-degree Thursday afternoon, Gov. Bob Wise put on his driving sunglasses, strode to the parking lot outside the west wing of the Capitol and hopped behind the wheel of his 1965 Corvair convertible.

The top was down.

Smiling, Wise said he fully agrees with the saying, "You are what you drive."

"Look at my car. Represents traditional values but with a youthful outlook," he said.

Wise is a part of a cult that harbors a secret love affair with Corvairs, the sleek 1960s automobile that some say was America's sporty answer to the German-designed Volkswagen Beetle. The typical Corvair - like the Volkswagen - had an air-cooled engine in the back of the automobile.

Wise's 1965 model - which is maroon with white vinyl seats - has two carburetors and a six-cylinder, 140-horsepower engine.

"If it's 50 degrees or warmer, I'll put down the top and drive it around town," Wise said. "I drove to Kroger Sunday for groceries."

Wise bought the Corvair two summers ago from a Jackson County couple. But he was already familiar with the automobile because it belonged to his father for two years in the mid-1960s.

"I guess it's sort of a mid-life crisis for me, but it was for my father, too. I was in high school when he owned the car, and I never got to drive it," Wise said.

The car escorted George Washington's homecoming queen at the 1965 GW-South Charleston football game, Wise said.

After Wise's father sold the car, it remained in the Charleston area for the next 30 years.

"Several years ago I saw this car at an Armed Forces Day parade in South Charleston. I told the owner it looked like the car my dad owned," Wise said. "When I looked at it a little closer, I realized it was the same car."

Several years and one owner later, a Jackson County couple decided to sell it. The couple knew Wise and knew from documentation in the dash that the car belonged to Wise's father.

The couple contacted Wise, asking if he wanted to buy it.

Yes, indeed.

As he showed off his car Thursday afternoon to several onlookers, Wise was reminded of consumer advocate Ralph Nader's assessment of Corvairs: "Dangerous at any speed."

Wise insisted Nader was referring to the early '60s Corvairs, before several mechanical alterations were made to the exhaust system.

Then Wise added, "You're going to believe Ralph Nader? Look what he did to our electoral process."

Nader ran for president in 2000 as a third-party candidate. Many political observers believe the votes Nader received came at the expense of Democratic nominee Al Gore, who lost the election to GOP nominee George W. Bush.

"Ralph Nader wasn't talking about my car," Wise said.

Submitted by Mike Donley

Chicken Soup for the Beer Drinker

I feel sorry for people who don't drink. When they wake up in the morning, that's as good as they're going to feel all day.

--Frank Sinatra

An intelligent man is sometimes forced to be drunk to spend time with his fools.

--Ernest Hemingway

A woman drove me to drink and I didn't even have the decency to thank her.

--W.C. Fields

When I read about the evils of drinking, I gave up reading.

--Henny Youngman

24 hours in a day, 24 beers in a case....Coincidence?

--Stephen Wright

When we drink, we get drunk.

When we get drunk, we fall asleep.

When we fall asleep, we commit no sin.

When we commit no sin, we go to heaven.

Sooooo, let's all get drunk and go to heaven!

--Brian O'Rourke

Beer is proof that God loves us and wants us to be happy.

--Benjamin Franklin

Vulcan Corvair Enthusiasts, a chapter of the Corvair Society of America, is a non-profit club dedicated to the preservation and restoration of the Corvair automobile.

VCE dues of \$20/year pay for a family membership and 12 issues of the *Oil Drop* newsletter.

President: Ed Keller
205/823-5424

Vice President: Harold Hartline
205/491-5253

VP/Membership/Newsletter: Russell Noble
205/822-6092

Secretary: Joe Doughty
205/995-0131

Treasurer: John Hathaway
205/408-4063

Hospitality: Jon & Sarah Keeton
CEO of Enforcement: Jewel Hinkle

Web: <http://clubs.hemmings.com/vulcancorvair/>



Have you got your engine in shape for Summer?



Vulcan Corvair Enthusiasts
PO Box 59071
Birmingham, AL 35259-9071



T
H
E

OIL DROP

THE OFFICIAL NEWSLETTER OF THE VULCAN CORVAIR ENTHUSIASTS Vol 22, No 4

April **2001**

From the Prez

The club received notice from Clark's Corvaire of a piston sales promotion. Yours truly dutifully filled out the paperwork to receive the goodies and faxed it to Clark's. I received a return FAX almost immediately confirming the date, Friday August 17th to receive and utilize the following at our meeting:

1. Products to be displayed - New Clark's pistons, new valves, viton crank seals, graphite exhaust packings, and pre-bent brake line sets.
2. Video - approximately 1 hour
3. Door prizes - (or raffle? - or auction?)
Two (2) \$10 gift certificates
Grand Prize - Set of pistons or set of pre-bent brake lines

Meanwhile, back at the ranch, try to make the meeting on April 20th if you can, and the Carshow/Picnic at Old Town Helena on Saturday, the 21st.

See Ya, Ed

--- DUES are DUE --- DUES are DUE ---

Next Meeting:

Date: Friday, April 20th, 2001

Time: 7:00 PM

Place: Vestavia Hills Library on Hwy 31

Peggy Bagwell along with Jon and Sarah Keeton will be serving dinner for the April meeting. The menu is rumored to be a surprise...don't miss it. Drive those Vairs!

Dues Notice:

If there is an extra sticker on the front of your *Oil Drop*, your dues are overdue. Bring your \$20 to the meeting or mail the funds to:

John Hathaway
1406 highland Lakes Trail
Birmingham, AL 35242

Calendar of Events

- Apr 21 Car Show & Picnic - Lunch & Music@
"Old Town" - Helena
- Apr 21 Enterprise, AL Car and Truck show
- Apr 27-29 Helen, GA Springfest
- May 4-6 Virginia Vair Fair - Hampton, VA
- May 5 AACA Southeastern Division National
Spring Meet - Talladega, AL
- May 5 YWEA World Missions Car and Truck
Show - Pell City
- May 12 Pontiac Show - Zamora Temple
- May 12 Spring Fling Car and Truck Show -
Leeds
- May 12 Sports Cars at Tannehill
- May 18-20 Annual Vair Pilgrimage @ Charleston,
SC

Calendar of Events (con'd)

- Jul 25-28 CORSA International Convention -
Chicago, IL
- Sept 15 Tour to Millard Young's - Piedmont, AL
- Sept 29 Wings and Wheels Car Show - Bessemer
Airport

March Meeting Minutes

The meeting was held at 7:00 PM at the Vestavia Library at which a delicious fried chicken meal with all the trimmings was served by Carol and Ed Keller.

The turn out for the meeting was the best we have had for some time with approximately 38 members and several children present.

After the meal President Ed Keller called the business meeting to order and asked the treasurer John Hathaway to give a treasurer's report. He reported that as of January 1, 2001 we had a balance in the bank of \$362.75 left over from calendar year 2000 and after collecting some dues for 2001 we now had a bank balance of 676.75 as of March 16, 2001.

Ed Keller reminded everyone of the Helen Georgia car show coming up on April 27-29.

Bob Siemens reported that the North Alabama Corvair Club, which had disbanded some time ago, had now been reactivated and was meeting at the old Greenbriar restaurant just off I-565.

Ed Keller stated that Joe Molina was promoting a car show and picnic, with a live band, at Helena and wants us to have some Corvairs in the show. Ed would like to see the club participate.

A discussion was held concerning several Corvairs for sale including a 64 advertised in the *Oil Drop* by Harold Hartline's cousin, a 65 coupe being sold by Phil Harrod, a 65 coupe in Alabaster and a 600 model 700 coupe in Fayette, AL.

Jewel Hinkle called for volunteers to serve the meal at the April meeting and Jon and Sarah Keeton along with Peggy Bagby agreed to serve the meal. Harold Hartline announce that immediately after the business meeting adjournment he was going to hold a tech session using a home made rig to demonstrate how to balance rods and pistons.

On motion by Bob Siemens, seconded by Owen Miller, the meeting was adjourned.

Joe Doughty, Secretary



Was the Corvair too 'Expensive' to Build?

The story about Corvair being more costly to produce is partly true. It cost GM about as much to redesign the 200,000 sales a year LM Corvair as the 11,000,000 a year full size cars pretty much, so engineering and tooling costs per unit were a little higher than on say, a high volume car like an Impala. This might work out to a few dollars per car, GM would have spent about 25-50 million dollars on a typical redesign in those days. Tooling costs are amortized against the number of vehicles you can make on a set of tools, and Corvair was OK in that respect, GM wore out the tooling by the end of the 1969's, so that's neither here nor there.

Corvair likely cost GM perhaps \$12 a car or thereabout more for charges like this compared to an Impala, but paid the Corporation larger benefits in other ways - Corvair sales were largely coming out of sales that would have gone to other makes and not poached from GM customers. This meant most Corvairs represented extra business for GM they wouldn't have otherwise enjoyed. Also, a Corvair buyer might well have traded up later to another GM car, which is good for GM. Ford Falcon nearly put Ford out of business - small cars don't cost much less to build than big ones, and sell at a much lower price, which makes them relatively unprofitable. Ford had a problem in that people who may have normally bought a stripped down full size Ford often bought a Falcon instead, and this didn't make Ford much money, you want people to switch from unprofitable cars to profitable ones, not the reverse. Corvair did not steal many sales from shoppers looking at Biscaynes and so it helped overall on market share and bottom line.

Bottom line is that Chevrolet made money on every Corvair right thru end of production and did quite well with it. GM can turn a profit on any line selling more than 15,000 units a year as a rule, and the last '69's were fully amortized, and cost GM virtually nothing to build by that point. It is interesting that there was a plan to build a 1970½ Corvair with a reskinned body. Chevrolet very nearly discontinued Chevy II and Camaro for 1970 and had an alternate plan to build Corvair-based small cars into the 1970's. These fell thru by mid 1968, but there are some pictures and other materials indicating that it could have worked out the other way. The Vega cost GM 200 million dollars to develop, remember.

Posted By Brent Covey 3/18/01 on Corvair Center

******* VCE Classifieds *******

For Sale

1964 Monza convertible Recent saddle bronze paint and white top. New WSW tires, wire caps, good brakes. Floorboards have been cleaned, rustproofed, and primed. Underside cleaned and painted. Runs good. Was original factory air car. Have all parts to restore A/C. Needs new interior. \$3,400 OBO. Ed Keller (205) 823-5424

For Sale

1964 Monza Coupe 4-speed, 66,500 miles, light tan, dark tan interior, 2nd owner, B'ham car, new tires, stored inside 10yrs, \$1400. Call Roy Laughlin 681-6856.

Parts Wanted

Late model parts (1965): good front seats, turbo heat shield, air cleaner lid (turbo), turbo muffler bracket, turbo right heater hose sheet metal, heavy duty pressure plate, 'Corsa' fender emblem, jack, alternator, trunk lock cylinder and retainer, 'Corvair' deck emblem, bottom cove trim, rear convertible weights. Call David Langner, 298-3531 (work) or 655-9445 (home) or 676-5632 on pager.

VCE Wins in Florida

Ed Keller placed 2nd with his 1966 Lemonwood Yellow Corsa convertible at the Pensacola show in February as shown in the *CORSA Communiqué* article below. Way to go Ed!

Corvair Lovers Holiday			
Early Closed		Forward Control	
1 Howard Furr, Milton, FL	'64 white Monza sedan	1 Charles Mitchell, Largo, FL	'62 white/red Rampside
2 Ed Graveline, Dowling Park, FL	'61 teal Monza sedan	2 David Berry, Huntsville, AL	'61 red/white Rampside
3 Adam Custer, Pace, FL	'63 Azure Aqua coupe	3 Will Elliott, Wewahitchka, FL	'62 green/gold Greenbrier
Early Open		Modified	
1 James Law, Albany, GA	'64 Mist Blue Monza	1 Don Taylor, Covington, LA	'66 red Corsa coupe
2 Ed Lindsay, Milton, FL	'64 Azure Aqua Spyder	2 Ken Overby, S. Daytona, FL	'66 white/blue 500 coupe
Late Closed		3 Walter Horst, Crestview, FL	'65 Monza conv.
1 Norman Coates, Webster, NY	'65 Mist Blue Monza coupe	Longest Distance	
2 Ed Lindsay, Milton, FL	'66 Emerald Green Corsa coupe	Earl Jones, Zebulon, NC	800+ miles
3 Martin Bell, Panama City, FL	'65 white Monza coupe	Hard luck	
Late Open		Susan Dooley, Jackson, MS	broken piston
1 Bill Clemens, Panama City, FL	'67 black/gold Monza	Best of Show	
2 Ed Keller, Birmingham, AL	'66 yellow Monza	Richard Jenkins, Rock Hill, SC	'63 maroon/beige Greenbrier
3 Sheryle Blim, Pensacola, FL	'65 maroon Corsa		

CORSA Elections

If you are a CORSA member, you may already know this - if not, the annual election for the Board of Directors is going on right now. One Central Division candidate is from our own backyard. He is Robert Hill from Hazel Green, AL and is the driving force behind the North Alabama Corvair Club's resurrection the last few months.

This space intentionally left blank...
Help me fill it next time!



Vulcan Corvair Enthusiasts, a chapter of the Corvair Society of America, is a non-profit club dedicated to the preservation and restoration of the Corvair automobile.

VCE dues of \$20/year pay for a family membership and 12 issues of the *Oil Drop* newsletter.

President: Ed Keller
205/823-5424

Vice President: Harold Hartline
205/491-5253

VP/Membership/Newsletter: Russell Noble
205/822-6092

Secretary: Joe Doughty
205/995-0131

Treasurer: John Hathaway
205/408-4063

Hospitality: Jon & Sarah Keeton

CEO of Enforcement: Jewel Hinkle

Web: <http://clubs.hemmings.com/vulcancorvair/>



Walt & Marilyn Davison's Ultra Van among Egyptian Ruins



Vulcan Corvair Enthusiasts
PO Box 59071
Birmingham, AL 35259-9071



T
H
E

OIL DROP

THE OFFICIAL NEWSLETTER OF THE VULCAN CORVAIR ENTHUSIASTS Vol 22, No 5

May 2001

From the Prez

AACA National spring meet, Talledega - Sat., May 5th Those of you that did not go to Talledega on May 5th really missed a chance to see some rare and beautifully restored automobiles - Pierce Arrows, Packards, V-16 Cadillacs, Locomobiles, Pontiacs, Mustangs and even a couple of Chevy Cameo pick-ups. All, of course, restored to a high level. There were a couple of Corvairs, one in the driver's class, and one in the concour's class. Note: Jan and Charles Trotter and Buck Hinkle were seen in the crowd as well as Carol and yours truly.

Helen Springfest What a good show this year for the Atlanta Club! Clark's and Wall's Corvair were both there as well as individual vendors - lots of parts came home with our members. Our club was well represented with 24 VCE members plus a couple of visitors attending. The Hinkles and Smiths went over on Wednesday to take in a little mountain air and scenery plus a few antique shops before arriving at Helen on Thursday. The Hartlines and Kellers took the scenic route through Rome, GA on Thursday, and met the Millers in Helen. Other members who came were the Hunters with their children, Brannon and Holly, the Siemens, Langners, Steadmans, Walt

Davison, Norman Rodgers, John Hathaway and Elsie. The weather was beautiful with cool nights and warm days. The show cars were really nice with several rare ones like a '63 coupe with 19,000 original miles - never restored but looked brand new. Unfortunately, there was some totally unacceptable behavior by a couple of VCE members Friday night, who shall remain nameless, but their initials are J.H. and W.D. We were certainly embarrassed and there has been some discussion regarding a reprimand by the discipline committee, maybe 50 lashes with a wet noodle.

Ed

Next Meeting:

Date: Friday, May 18th, 2001

Time: 7:00 PM

Place: Vestavia Hills Library on Hwy 31

Bob and Wilma Siemens will be serving dinner for the May meeting. Bring your favorite Corvair for future *Oil Drop* cover photos.

Cruise-In Locations

1st Fri Arby's - Moody

1st Sat WalMart - Hwy 31, Pelham

2nd Sat Burger King - Center Point Rd.

WalMart - Hwy 31, Clanton

3rd Sat Arby's - Trussville

4th sat WalMart - Bessemer

Calendar of Events

- May 12 Pontiac Show - Zamora Temple
May 12 Spring Fling Car and Truck Show - Leeds
May 12 Sports Cars at Tannehill
May 18-20 Annual Vair Pilgrimage @ Charleston, SC
May 19 Antique & Classic Car Show - Huntsville - UAH campus
May 27 River Run VII - Open Car Show - Chattanooga, TN
Jun 15-17 Noccalula Falls Car Show and Swap Meet
Jul 25-28 CORSA International Convention - Chicago, IL
Jul 28 Car and Truck Show - Ripley, MS
Sept 8 17th Annual Antique & Classic Car Show - Oxford, AL
Sept 15 Tour to Millard Young's - Piedmont, AL
Sept 29 Wings and Wheels Car Show - Bessemer Airport

March Meeting Minutes

The meeting was held at 7:00 P.M. at the Vestavia Library and a delicious meal was served by Sarah Keeton and Peggy Bagby and enjoyed by all.

After the meal President Keller called the business meeting to order and asked for a treasurer's report. Treasurer John Hathaway reported that we had a bank balance of \$606.50 as of April 20, 2001.

A general discussion was held concerning the cost of furnishing a meal at the club meetings and John Hathaway stated that he felt we should pay those furnishing the meal the actual cost as substantiated by tickets or receipts kept and presented to the treasurer.

Bob Siemens made a motion, seconded by Norman Rodgers, that the club reimburse the club members who prepare and serve a meal at a club meeting for the actual cost of the food as substantiated by tickets and receipts and that the club continue to collect \$1 per person present at the meeting and that these funds so collected be placed in the club treasury. The motion carried.

President Keller announced the sad news of the death of one of our former members, Jim Floyd.

Bob Siemens reported that the reactivated North Alabama Corvair Club was up and running and that they wanted to have a joint function of some kind in the near future with our club.

President Keller mentioned the car show and picnic with a live band that is to be held tomorrow, Saturday, April 21, 2001, at Helena. He indicated that he would attend but there did not seem to be any others who planned to attend.

President Keller asked for a show of hands of those planning to attend the upcoming "Springfest" at Helen, Georgia and it appeared that we will have very good representation at that event on April 27, 28, and 29, 2001.

Clark's Corvair Parts had made us an offer for our August 2001 meeting to send us a video, two \$10 gift certificates, a free set of pistons and some refreshments. President Keller stated that he would try to get that moved up to an earlier date if possible.

A discussion was held concerning several cars for sale.

Bob and Wilma Siemens volunteered to serve the meal at our May meeting.

Walt Davison announced that he would hold a short tech session on alternators following adjournment of the business meeting.

On motion by John Hathaway, seconded by Bob Siemens the meeting was adjourned.

Joe Doughty, Secretary

********VCE Classifieds********

For Sale

1964 Monza convertible Recent saddle bronze paint and white top. New WSW tires, wire caps, good brakes. Floorboards have been cleaned, rustproofed, and primed. Underside cleaned and painted. Runs good. Was original factory air car. Have all parts to restore A/C. Needs new interior. \$3,400 OBO. Ed Keller (205) 823-5424

For Sale

1964 Monza Coupe 4-speed, 66,500 miles, light tan, dark tan interior, 2nd owner, B'ham car, new tires, stored inside 10yrs, \$1400. Call Roy Laughlin 681-6856.

Parts Wanted

Late model parts (1965): good front seats, turbo heat shield, air cleaner lid (turbo), turbo muffler bracket, turbo right heater hose sheet metal, heavy duty pressure plate, 'Corsa' fender emblem, jack, alternator, trunk lock cylinder and retainer, 'Corvair' deck emblem, bottom cove trim, rear convertible weights. Call David Langner, 298-3531 (work) or 655-9445 (home) or 676-5632 on pager.

Corvairs in the news

This article below appeared in the May 4, 2001 edition of 'City Scene' inside *The Birmingham News*. Looks like Ultra Vans are popping up everywhere...how about that, Walt?

BOOK

Available now



Dori and Joseph DeCamillis

▲ Birmingham artists **Dori and Joseph DeCamillis** appear so calm, assured and happy at gallery openings, you'd think the couple hadn't a care in the cosmos. Their careers may be on track now, but the two didn't always lead such charmed lives. Dori describes their journey from Colorado to Alabama — and reveals their personal and professional struggles with refreshing honesty — in *The Freeway*, an autobiographical journal published by Xlibris Press. Its subtitle: *Two Young Painters in Love, On the Road in Search of Home*. The DeCamillises faced poverty, rejection, mosquitoes and mechanical failures as they traveled across the country in Lucy, a funkily refurbished Ultra Van. Read all about it now, before Dori's book is picked up by another publisher and edited into a shorter, smoother but less detailed volume. More information on *The Freeway* can be found at the

DeCamillis Web site, www.doriandjoseph.com. It's also available when Dori and Joseph exhibit their works at shows and art festivals.
— Mary Colurso



2001 VCE Member Phone/Address List

<u>Peggy Bagby</u> 8177 Cedar Mountain Rd Pinson, AL 35126 205-681-7014	<u>Walt & Marilyn Davison</u> 156 Summer Place Lane Sylacauga, AL 35150 256-245-9728
--	---

<u>Mike Donley</u> 8 Hibiscus Drive Montgomery, AL 36109 334-272-7793	<u>Joe & Rozelle Doughty</u> 324 North Lake Road Birmingham, AL 35242 205-995-0131
<u>Charlie & Marie Drake</u> 6454 New Castle Road Morris, AL 35116 205-681-7143	<u>Roy Dutton</u> 930 Prospect Rd Nauvoo, AL 35578
<u>Curtis Hare</u> 3707 Havenview Circle Birmingham, AL 35216 205-823-2165	<u>Harold & Louise Hartline</u> 1920 Longview Drive Hueytown, AL 35023 205-491-5253
<u>Phil & Carol Hartline</u> 905 Echo Trail Warrior, AL 35180 205-590-0141	<u>John Hathaway</u> 1406 Highland Lakes Trail Birmingham, AL 35242 205-408-4063
<u>Buck & Jewell Hinkle</u> 4142 Terrace R West Birmingham, AL 35208 205-780-0549	<u>Mickey & Robin Hunter</u> 1801 Danville Rd SW Decatur, AL 35601 256-306-0435
<u>Jon & Sarah Keeton</u> 2008 Elkwood Drive Fultondale, AL 35068 205-841-5169	<u>Ed & Carol Keller</u> 2461 Jannebo Road Birmingham, AL 35216 205-823-5424
<u>Ethel Mae Lankford</u> 116 Chandler Drive Alabaster, AL 35007 205-620-6848	<u>David & Amy Langner</u> 113 Munger Circle Trussville, AL 35173 205-655-9445
<u>Owen & Joyce Miller</u> 601 Avondale Road Montgomery, AL 36109 334-272-7085	<u>Russell & Debbie Noble</u> 3416 Danner Circle Birmingham, AL 35243 205-822-6092
<u>Frank Ranelli</u> 1725 Hendrix Drive Birmingham, AL 35214 205-798-3787	<u>Norman Rodgers</u> 408 South Broad Street Albertville, AL 35211 205-878-1810
<u>Chris & Francis Rothe</u> 104 Gardenia Circle Pleasant Grove, AL 35127 205-744-2072	<u>Bob & Wilma Siemens</u> 1725 Buck Island Drive Guntersville, AL 35976 205-582-2175
<u>Jerry & Sarah Smith</u> 595 Browning Road Odenville, AL 35120 205-640-6952	<u>Grant & Mary Snead</u> 4427 Ridgewood Rd East Tuscaloosa, AL 35404 205-553-4210
<u>Floyd T. Snider</u> 4960 Big Oak Drive Southside, AL 35907	<u>Joe & Ann Steadman</u> 1629 Arrowhead Road Jasper, AL 35504 205-384-9576
<u>Richard & Sandy Stolzmann</u> 376 Burgess Drive Springville, AL 35146 205-467-6444	<u>Charles & Jan Trotter</u> 102 Allen Road Pell City, AL 35125 205-338-6828
<u>Dick & Barbara Witkos</u> 3112 Clayburne Road Dothan, AL 36303 334-792-8528	

Vulcan Corvair Enthusiasts, a chapter of the Corvair Society of America, is a non-profit club dedicated to the preservation and restoration of the Corvair automobile.

VCE dues of \$20/year pay for a family membership and 12 issues of the *Oil Drop* newsletter.

President: Ed Keller
205/823-5424

Vice President: Harold Hartline
205/491-5253

VP/Membership/Newsletter: Russell Noble
205/822-6092

Secretary: Joe Doughty
205/995-0131

Treasurer: John Hathaway
205/408-4063

Hospitality: Jon & Sarah Keeton

CEO of Enforcement: Jewel Hinkle

Web: <http://clubs.hemmings.com/vulcancorvair/>



Who says Corvairs won't drive you crazy? Just look at this nut!



Vulcan Corvair Enthusiasts
PO Box 59071
Birmingham, AL 35259-9071



T
H
E

OIL DROP

THE OFFICIAL NEWSLETTER OF THE VULCAN CORVAIR ENTHUSIASTS Vol 22, No 6

June 2001

From the Prez

Well, sports fans, the national Convention is just over a month away. Several of our members have indicated they will be going. Meanwhile, concerning the Clark's Piston Program, yours truly responded to Clark's Corvairs per their instructions, and sent in our 1st, 2nd, and 3rd choices for the date we would like to receive the video and free goodies. These were our Friday meeting dates in July, August and September. They responded by giving us August 17th. One or two of our members were unhappy that the date was so far out. So, in order to speed things up, I called Clark's and asked for an earlier date on a Saturday. They agreed to Sat., June 30th. My suggestion would be for us guys to plan on a hot dog cook-out at some suitable location, view the video, and decide on what to do with the free stuff, etc. The gals can come if they want to, or? At any rate, I am sure they can entertain themselves without having to be bored with the video, etc.

Ed

In Memoriam

VCE pauses for a moment to recognize the passing of Grant Snead. He will be missed.

Next Meeting:

Date: Friday, June 15th, 2001

Time: 7:00 PM

Place: Vestavia Hills Library on Hwy 31

Jerry and Sarah Smith will be serving dinner for the June meeting. Come check out what the Smith's will dish up. Drive those Corvairs!

Cruise-In Locations

- 1st Fri Arby's - Moody
- 1st Sat WalMart - Hwy 31, Pelham
- 2nd Sat Burger King - Center Point Rd.
WalMart - Hwy 31, Clanton
- 3rd Sat Arby's - Trussville
- 4th sat WalMart - Bessemer
WalMart (?) - Sylacauga

Calendar of Events

- Jun 15-17 Noccalula Falls Car Show and Swap Meet
- Jul 25-28 CORSA International Convention - Chicago, IL
- Jul 28 Car and Truck Show - Ripley, MS
- Sept 8 17th Annual Antique & Classic Car Show - Oxford, AL
- Sept 15 Tour to Millard Young's - Piedmont, AL
- Sept 29 Wings and Wheels Car Show - Bessemer Airport
- Oct 5-6 Vairs at the Fair - Heart of GA Corvairs
- Oct 19-21 Fall Corvair Affair - Charlotte, NC

May Meeting Minutes

An excellent meal, served by Bob and Wilma Siemens, was enjoyed by all at 7:00 P.M. at the Vestavia Library.

After the meal the business meeting was opened by president Ed Keller.

Treasurer, John Hathaway, gave a financial report in which he reported that our bank balance as of 5/18/2001 was \$619.45.

Bob Siemens again reminded us that the north Alabama Corvair Club desires to set up a joint outing of some type with our club at some date in the near future. He also stated that the North Alabama Club is meeting on June 2 at the Cracker Barrel in Cullman and from there will tour the Catholic monastery at Hanceville. Any of our group that would like to join them is welcome to do so.

President Keller mentioned several car shows coming up and reminded us of the CORSA International Convention in Chicago on June 25-28, 2001.

President Keller stated that he had been forwarded letters of two people who have expressed interest in joining a Corvair club. One of these lives in Chickasaw, near Mobile, and the other in Union Grove, near Arab. Since they both are nearer other club she is going to forward the letters to the West Florida Club and the North Alabama Club.

Jewel Hinkle reported on our sick members.

Frank Ranelli announced that he had a 1963 Rampside with powerglide for sale at \$2500. He bought it from Norman Rodgers and has done extensive work on it and it is in great shape.

John Hathaway and Walt Davison announced a short tech session on one aspect of powerglide transmissions to be held right after adjournment of the meeting.

On motion by Walt Davison, seconded by Jon Keeton, the meeting was adjourned.

Joe Doughty, Secretary

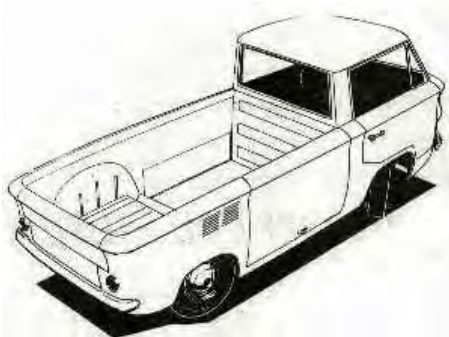

*******VCE Classifieds*******

For Sale

1961 Lakewood 100s of parts. Also a '63 Corvair in good condition, runs good. Located near Decatur. Contact Sandra Staggs at: n2junk@msn.com

For Sale

1964 Monza convertible Recent saddle bronze paint and white top. New WSW tires, wire caps, good brakes. Floorboards have been cleaned, rustproofed, and primed. Underside cleaned and painted. Runs good. Was original factory air car. Have all parts to restore A/C. Needs new interior. \$3,400 OBO. Ed Keller (205) 823-5424

For Sale

1964 Monza Coupe 4-speed, 66,500 miles, light tan, dark tan interior, 2nd owner, B'ham car, new tires, stored inside 10yrs, \$1400. Call Roy Laughlin 681-6856.

For Sale

1964 Monza Convertible powerglide, 56,000 actual miles, garage kept, original interior, rust free car. Has been painted, new carpet and heavy duty top installed. extra nice car, \$7,500. Firm price. 205/640-6952

For Sale

1964 Monza Convertible black interior and exterior, 4-speed, new paint, new bumpers, front trim, etc. Needs assembly and finishing, \$1,300 Ed Keller 205-785-5431 (D), 205-823-5424 (N)

For Sale

1965 Monza Coupe white, AC, auto, 74K miles, needs very little. Contact: Phil Harrod

Parts Wanted

Late model parts (1965): good front seats, turbo heat shield, air cleaner lid (turbo), turbo muffler bracket, turbo right heater hose sheet metal, heavy duty pressure plate, 'Corsa' fender emblem, jack, alternator, trunk lock cylinder and retainer, 'Corvair' deck emblem, bottom cove trim, rear convertible weights. Call David Langner, 298-3531 (work) or 655-9445 (home) or 676-5632 on pager.

Vulcan Corvair Enthusiasts WEBSITE

Several folks have asked about the VCE website. Well, the site address is on the front cover of the *OIL DROP* every month! Note that no classified ads will be posted by Hemmings on our ****free**** site, so they have to be stripped from the *OIL DROP* every month before the site is updated.

<http://clubs.hemmings.com/vulcancorvair/>

Tech Session

This article appeared in 11/00 issue of the *Enchanted Corvairs Newsletter* of Corvairs of New Mexico. The author is Richard Finch.

Subject: Spark Plug Lubricant

Jim, that was a good topic for the tech session. Corvair people and other owners of cars with aluminum cylinder heads would be interested to know that piston engine aircraft manufacturers such as Lycoming and Continental all advocate the use of graphite lubricant for spark plugs used in aluminum heads. Champion Spark Plug company makes a liquid based graphite spark plug thread lubricant that comes in a small bottle with an applicator brush inside that is a lot like a bottle of fingernail polish, except that the consistency of the liquid graphite in the bottle is like thin paint.

This spark plug thread lubricant is intended to be applied each time the spark plugs are removed and reinstalled which is usually at 100 hour intervals in most piston engine aircraft. Even the FAA recommends a graphite thread lubricant as a prevention of galled or stripped threads in aircraft engines. The Champion lube can be purchased at most local aircraft service centers and aircraft supply stores.

to prevent thread galling from rough threads on new \$1.50 apiece spark plugs, dress each new spark plug on a rotary motor wire brush to remove the manufacturing burrs. Even brand new \$30 apiece aircraft spark plugs have burrs on their threads.

Tool Time

This article also appeared in 11/00 issue of the *Enchanted Corvairs Newsletter* of Corvairs of New Mexico. The author is Corey Homer.

Here is another tidbit I will throw out to the group regarding tools. I read this on the internet a few days ago. If this is common knowledge, I apologize and will crawl back under the rock I live beneath.

The article was titled "Who makes Craftsman Tools." We all know that Sears, like many other major brand names, just put their logo on products made by other manufacturers. Well, what about hand tools? Today there are only three major players in the hand tool market: Stanley, Danaher and Snap-On. Now, this is where it gets interesting.

Up until 1994, Craftsman brand was made by Stanley. The tools came down the same assembly lines and went through the same forging processes. After 1994, Danaher won the contract. Danaher also produces the Matco brand tools. Stanley currently builds MAC tools, Proto tools, the Home Depot Husky brand, and their own label within the same assembly plants. About the only difference is that the Proto tools go through additional quality control since they are used by NASA, the military and industrial customers. Snap-On produces the Lowe's Kobalt brand as well as their own label. In addition to these three companies, there are a handful of minor players like Vermont American and many import brand tools.

All the hand tools today carry similar 'lifetime' warranties. In fact, Husky will replace any Craftsman tool with an equivalent version of their own brand.

As for things like torque wrenches, and special application tools, you get what you pay for. In many cases the calibrated tools that are more expensive tend to have tighter tolerance bands and higher limits. As far as a run of the mill 12-pt 3/8" drive 1/2" socket, I think I will look for the cheapest of the aforementioned companies. Unfortunately, from what I have seen Stanley doesn't make as wide a variety of socket and hand tool sizes as some of the other companies like Craftsman (oops, I mean Danaher).

The original memo was written by a gentleman who worked at the Proto division of Stanley Tools. He by no means claims to be the final word on tools, but felt he should inform people of what he knew. I hope this won't turn into a virtual vairs debate as to WHO has the best/highest quality tool collection! I only wanted to inform people like me who are doing their Corvair on a budget and cannot afford to restore a car as well as turn their garage into a Snap-On distribution center.

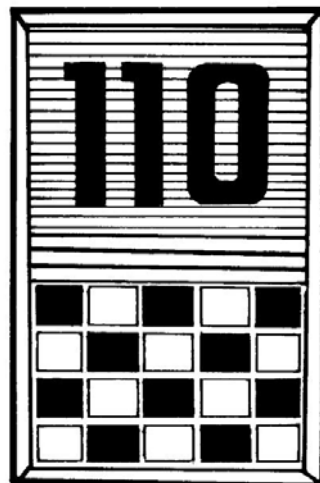

Vulcan Corvair Enthusiasts, a chapter of the Corvair Society of America, is a non-profit club dedicated to the preservation and restoration of the Corvair automobile.

VCE dues of \$20/year pay for a family membership and 12 issues of the *Oil Drop* newsletter.

President: Ed Keller
205/823-5424

Vice President: Harold Hartline
205/491-5253

VP/Membership/Newsletter: Russell Noble
205/822-6092

Secretary: Joe Doughty
205/995-0131

Treasurer: John Hathaway
205/408-4063

Hospitality: Jon & Sarah Keeton
CEO of Enforcement: Jewel Hinkle

Web: <http://clubs.hemmings.com/vulcancorvair/>



Bob and Wilma Siemens 1960 Corvair '700'. Dig that car!



Vulcan Corvair Enthusiasts
PO Box 59071
Birmingham, AL 35259-9071



T
H
E

OIL DROP

THE OFFICIAL NEWSLETTER OF THE VULCAN CORVAIR ENTHUSIASTS Vol 22, No 7

July 2001

From the Prez

I received the material from Clark's for the Piston Program and the guys met at the library on Friday, June 29th and viewed the samples, video, etc. Carol grilled some hotdogs and we only had to warm up the buns and dogs at the library. It was technically interesting - looks like Clark's is trying to furnish some high quality items

Ed

From the Editor

The *Oil Drop* is essentially an announcement for this month's meeting as vacation timing and other stuff has clogged the calendar. Back to the regular format next month!

Next Meeting:

Date: Friday, July 20th, 2001

Time: 7:00 PM

Place: Vestavia Hills Library on Hwy 31

Owen and Joyce Miller will be serving dinner for the July meeting. Come have some Vair fun and consume what the Millers will dish up. Drive those crazy Corvairs and you too can end up on the cover like Bob!

Cruise-In Locations

- 1st Fri Arby's - Moody
- 1st Sat WalMart - Hwy 31, Pelham
- 2nd Sat Burger King - Center Point Rd.
WalMart - Hwy 31, Clanton
- 3rd Sat Arby's - Trussville
- 4th Sat Wal-Mart - Bessemer
WalMart (?)- Sylacauga

Calendar of Events

- Jul 14 Car and Truck Show - Leeds Memorial Park
- Jul 25-28 CORSA International Convention - Chicago, IL
- Jul 28 Car and Truck Show - Ripley, MS
- Sept 8 17th Annual Antique & Classic Car Show - Oxford, AL
- Sept 15 Tour to Millard Young's - Piedmont, AL
- Sep 23-24 Nocalula Falls Car Show and Swap Meet
- Sept 29 Wings and Wheels Car Show - Bessemer Airport
- Oct 5-6 Vairs at the Fair - Heart of GA Corvairs
- Oct 13 Car Show - Benefit for American Cancer Society - Pelham Wal-Mart
- Oct 19-21 Fall Corvair Affair - Charlotte, NC
- Oct 20 Car and Truck Show - Children's Hospital benefit - Arby's on Clay/Chalkville Road

2002

- Feb 14-15 Corvair Lovers' Holiday - Navarre, FL
- Jun 26-29 CORSA Convention - Flagstaff, AZ

Vulcan Corvair Enthusiasts, a chapter of the Corvair Society of America, is a non-profit club dedicated to the preservation and restoration of the Corvair automobile.

VCE dues of \$20/year pay for a family membership and 12 issues of the *Oil Drop* newsletter.

President: Ed Keller
205/823-5424

Vice President: Harold Hartline
205/491-5253

VP/Membership/Newsletter: Russell Noble
205/822-6092

Secretary: Joe Doughty
205/995-0131

Treasurer: John Hathaway
205/408-4063

Hospitality: Jon & Sarah Keeton

CEO of Enforcement: Jewel Hinkle

Web: <http://clubs.hemmings.com/vulcancorvair/>



Richard & Sandy Stolzmann's '67 Monza under construction!



Vulcan Corvair Enthusiasts
PO Box 59071
Birmingham, AL 35259-9071



What a meal at the July meeting!
Thanks to the Millers!

T
H
E

OIL DROP



THE OFFICIAL NEWSLETTER OF THE VULCAN CORVAIR ENTHUSIASTS Vol 22, No 8

August 2001

From the Prez

The National Convention - From what I hear, the convention was a great success, with pleasant weather and a great location. Hopefully, we will have a complete report from Harold Hartline somewhere in this newsletter. hope to see you at the meeting on Friday, August 17th.

Ed

Next Meeting:

Date: Friday, August 17th, 2001

Time: 7:00 PM

Place: Vestavia Hills Library on Hwy 31

John Hathaway and Elise Pemberton will be serving dinner for the August meeting. No word on the menu - come check it out and remember, drive those Corvairs!

Cruise-In Locations

- 1st Fri Arby's - Moody
- 1st Sat WalMart - Hwy 31, Pelham
- 2nd Sat Burger King - Center Point Rd.
WalMart - Hwy 31, Clanton
- 3rd Sat Arby's - Trussville
- 4th Sat Wal-Mart - Bessemer
WalMart (?) - Sylacauga

Calendar of Events

- Sept 8 17th Annual Antique & Classic Car Show - Oxford, AL
- Sept 8 Pony Round-up (Mustangs) - Jim Skinner Ford
- Sept 15 Tour to Millard Young's - Piedmont, AL
- Sept 15-16 4th Annual Tractor, Car & Truck Show - \$3 adm., Fire Dept Benefit - New Market, AL
- Sep 23-24 Nocalula Falls Car Show and Swap Meet
- Sept 29 Wings and Wheels Car Show - Bessemer Airport
- Sept 29 Car, truck, & Cycle Show - Hanceville, AL benefiting fire & rescue on Michelle St.
- Sept 29 AACA Central AL Region Car Show - Eastdale Mall, Montgomery
- Oct 5-6 Vairs at the Fair - Heart of GA Corvairs
- Oct 6 19th Annual benefit Car Show and Corral, \$4 adm, Landmark Park - Dothan (Dick & Barbara Witkos)
- Oct 13 Car Show - Benefit for American Cancer Society - Pelham Wal-Mart
- Oct 19-21 Fall Corvairst Affair - Charlotte, NC
- Oct 20 Car and Truck Show - Children's Hospital benefit - Arby's on Clay/Chalkville Road

2002

- Feb 14-15 Corvairst Lovers' Holiday - Navarre, FL
- Jun 26-29 CORSA Convention - Flagstaff, AZ

****LATE PRESS RELEASE****

Harold Hartline will give a slide show of his trip (with others) to the CORSA Convention in Chicago last month at the August VCE meeting.



July Meeting Minutes

A great chicken finger meal was served by Owen and Joyce Miller and enjoyed by the about 30 attendees at 7:00PM at the Vestavia Library.

After the meal, the business meeting was opened by president Ed Keller.

Treasurer John Hathaway reported a VCE club bank balance of \$608.55.

Ed Keller and others mentioned the need for a road trip. Several potential destinations were discussed including Chattanooga, a Memphis to New Orleans run, day trip to the American Village in Montevallo, etc. Any definite date or trip location was deferred to later discussion.

A drawing was held for the Clark's 'goodies' and the results are below:

\$10 Clark's certificate - Frank Ranelli

\$10 Clark's certificate - Chris Rothe

Set of pistons - Bob Siemens

A tech session of sorts was announced by Ed Keller on fuel pumps following the business meeting.

On motion, the meeting was adjourned.

*Submitted by Russell Noble
(sub for Joe Doughty)*

Anatomy of a VCE Meeting

This article is for those that can't make it to the meetings and wonder what in the world goes on there. It is also for those wonderful folks that volunteer their time and effort to dish up the good food we are always served at meetings. I know that I for one am very appreciative of the servers! So, on to the July meeting....

Well, to say this meeting began with a bang is an understatement. As folks began arriving about 6:30-6:45, we were treated to a drenching thunderstorm with an awesome display of lightning you rarely see. Lightning was popping everywhere as we unloaded the Miller's food and fixin's. It was pretty bad. You may have heard that the St. Francis of Xavier church in B'ham was struck and partially burned.

A couple of brave souls ventured out in this weather in Corvairs (I chickened out). These Vair

nuts were the Kellers and Richard Stolzmann. Below are pictures of their drenched Corvairs...



The Keller's 1964

Stolzmann's 1967



Now it was time for the main course...food! The girls worked feverishly to set things up. Chicken fingers from Guthries, carrot salad, potato salad, another cold salad, watermelon, two cakes (one was caramel - my favorite)...YUM!



What a great job! Complete with ornaments featuring two small scale Corvairs as you can see on the front of the *Oil Drop*. Below is the completed deal - I'm getting hungry.



After consumption of all the food you could ever want, VCE members settled back into their chairs to be entertained by Ed Keller as he tried to run the meeting. After all, we had pistons and stuff to give away. An energetic crowd stared in awe as the winner's name was removed from the hat...Bob Siemens. What a lucky dog.



After some more business issues, it was time to clean up and head home. At least it wasn't raining!

See you next month...Frank Ranelli is supposed to bring back some convention slides to look over from his trip to Chicago.

President George W. Bush Visits B'ham



During G.W's visit in June to pad Jeff Session's coffers and take a look at Oak Mountain, his motorcade was led by none other than a nice LM Corvair. G.W. sure has good taste in cars.

Dual-Club Trip



VCE joined up with the resurgent North Alabama club in June for a nice Corvair ride to visit the Benedictine Sisters of Sacred Heart Monastery near Hanceville. Looks like an interesting place to visit.

Photo submitted by Bob Siemens

VCE Classifieds

1964 Monza convertible Recent saddle bronze paint and white top. New WSW tires, wire caps, good brakes. Floorboards have been cleaned, rustproofed, and primed. Underside cleaned and painted. Runs good. Was original factory air car. Have all parts to restore A/C. Needs new interior. \$3,400 OBO. Ed Keller (205) 823-5424

1964 Monza Convertible powerglide, 56,000 actual miles, garage kept, original interior, rust free car. Has been painted, new carpet and heavy duty top installed. extra nice car, \$7,500. Firm price. 205/640-6952

1964 Monza Convertible black interior and exterior, 4-speed, new paint, new bumpers, front trim, etc. Needs assembly and finishing, \$1,300. Ed Keller 205-785-5431 (D), 205-823-5424 (N)

1961 Lakewood 100s of parts. Also a '63 Corvair in good condition, runs good. Located near Decatur. Contact Sandra Staggs at n2junk@msn.com

64 Monza Coupe Original auto transmission, original 110HP engine, original factory interior, and 60,500 actual miles. Local car, original owner. I like the car, I just don't have the time to work on another project. Car has been re-painted once - stayed with original color (white). It resides in my shed out of most of the weather. Huntsville area. Call Ken Colburn at 256/837-2776 or email at ken_colburn@msn.com

Vulcan Corvair Enthusiasts, a chapter of the Corvair Society of America, is a non-profit club dedicated to the preservation and restoration of the Corvair automobile.

VCE dues of \$20/year pay for a family membership and 12 issues of the *Oil Drop* newsletter.

President: Ed Keller
205/823-5424

Vice President: Harold Hartline
205/491-5253

VP/Membership/Newsletter: Russell Noble
205/822-6092

Secretary: Joe Doughty
205/995-0131

Treasurer: John Hathaway
205/408-4063

Hospitality: Jon & Sarah Keeton
CEO of Enforcement: Jewel Hinkle

Web: <http://clubs.hemmings.com/vulcancorvair/>



Harold & Louise Hartline's Rampside is back on the road!



Vulcan Corvair Enthusiasts
PO Box 59071
Birmingham, AL 35259-9071



Dig that delicious ham!
Thanks to John and Elise!

T
H
E

OIL DROP



THE OFFICIAL NEWSLETTER OF THE VULCAN CORVAIR ENTHUSIASTS Vol 22, No 9

September 2001

From the Prez

By the time you receive this newsletter, the annual trip to Millard Young's will have come and gone. Hope many of you made the trip because the word is that this is the last one. Too bad, because this has been one of the nice trips of the year, with interesting cars, great food, great folks to talk with, and a lovely setting at the Young's home.

On Saturday, September 22nd, the Nocalula Falls swap meet is scheduled, with the show being either Saturday or Sunday. If we have a group going up, we should meet for breakfast or lunch. Be ready to talk about this at the meeting Friday night

Ed

Cruise-In Locations

- 1st Fri Arby's - Moody
- 1st Sat WalMart - Hwy 31, Pelham
- 2nd Sat Burger King - Center Point Rd.
WalMart - Hwy 31, Clanton
- 3rd Sat Arby's - Trussville
- 4th Sat Wal-Mart - Bessemer
WalMart (?) - Sylacauga

Next Meeting:

Date: Friday, September 21st, 2001

Time: 7:00 PM

Place: Vestavia Hills Library on Hwy 31

Harold Hartline and grandson Brannon will be serving dinner for the September meeting. It should be getting a little cooler, so drive those Corvairs!

Calendar of Events

- Sept 15 Tour to Millard Young's - Piedmont, AL
- Sept 15-16 4th Annual Tractor, Car & Truck Show - \$3 adm., Fire Dept Benefit - New Market, AL
- Sep 23-24 Nocalula Falls Car Show and Swap Meet
- Sept 23 Antique & Classic Car and Truck Show - Walker County Cruisers
- Sept 29 Wings and Wheels Car Show - Bessemer Airport
- Sept 29 Car, truck, & Cycle Show - Hanceville, benefiting fire & rescue on Michelle St.
- Sept 29 AACA Central AL Region Car Show - Eastdale Mall, Montgomery
- Oct 5-6 Vairs at the Fair - Heart of GA Corvairs
- Oct 6 19th Annual benefit Car Show and Corral, \$4 adm, Landmark Park - Dothan (Dick & Barbara Witkos)
- Oct 13 Car Show - Benefit for American Cancer Society - Pelham Wal-Mart
- Oct 19-21 Fall Corvaire Affair - Charlotte, NC
- Oct 20 Car and Truck Show - Children's Hospital benefit - Arby's on Clay/Chalkville Road

2002

- Feb 14-15 Corvaire Lovers' Holiday - Navarre, FL
- Jun 26-29 CORSA Convention - Flagstaff, AZ



August Meeting Minutes

With approximately 35 members present, the meeting was opened at 7:00 PM at the Vestavia library beginning with a very enjoyable meal served by Elsie Pemberton and John Hathaway. Following the meal the membership gave Elsie and John a big hand for a job well done

Following the completion of the meal the business meeting was called to order starting with a report by Treasurer, John Hathaway, stating that as of August 17th, 2001 we had a balance in our bank account of \$561.85.

President Ed Keller reported on various upcoming car shows and events.

Bob Siemens stated that a joint outing was scheduled on September 29 with the North Alabama Chapter for a tour of the Mercedes assembly plant at Vance and all members are invited to attend.

Russell Noble put on a computer controlled slide show of cars and events from the recent CORSA International Convention held at Chicago. (photos courtesy of Frank Ranelli and Chris Rothe - ed.) This was followed by a convention slide show put on by Harold Hartline of both the Daytona and Chicago conventions.

It was announced that at the September meeting the meal will be served by Harold Hartline and grandson, Brannon.

The meeting was then adjourned.

Submitted by Joe Doughty, Secretary

Convention Photos

For those of you that missed the great slide shows at the last meeting, here are a few selected photos. Thanks to Frank Ranelli for providing the digital shots...



A nicely done LM pickup



Very sharp LM 4-door



Cool LM race car



EM w/AC - note condenser location!



Clean EM coupe



Stately Greenbrier

Product Warnings:

"Caution: The contents of this bottle should not be fed to fish." -- *On a bottle of shampoo for dogs.*

"For external use only!" -- *On a curling iron.*

"Warning: This product can burn eyes." -- *On a curling iron.*

"Do not use in shower." -- *On a hair dryer.*

"Do not use while sleeping." -- *On a hair dryer.*

What New Owners Thought...

Here is a survey from the May 1965 Popular Mechanics magazine that polled '65 Corvair owners.

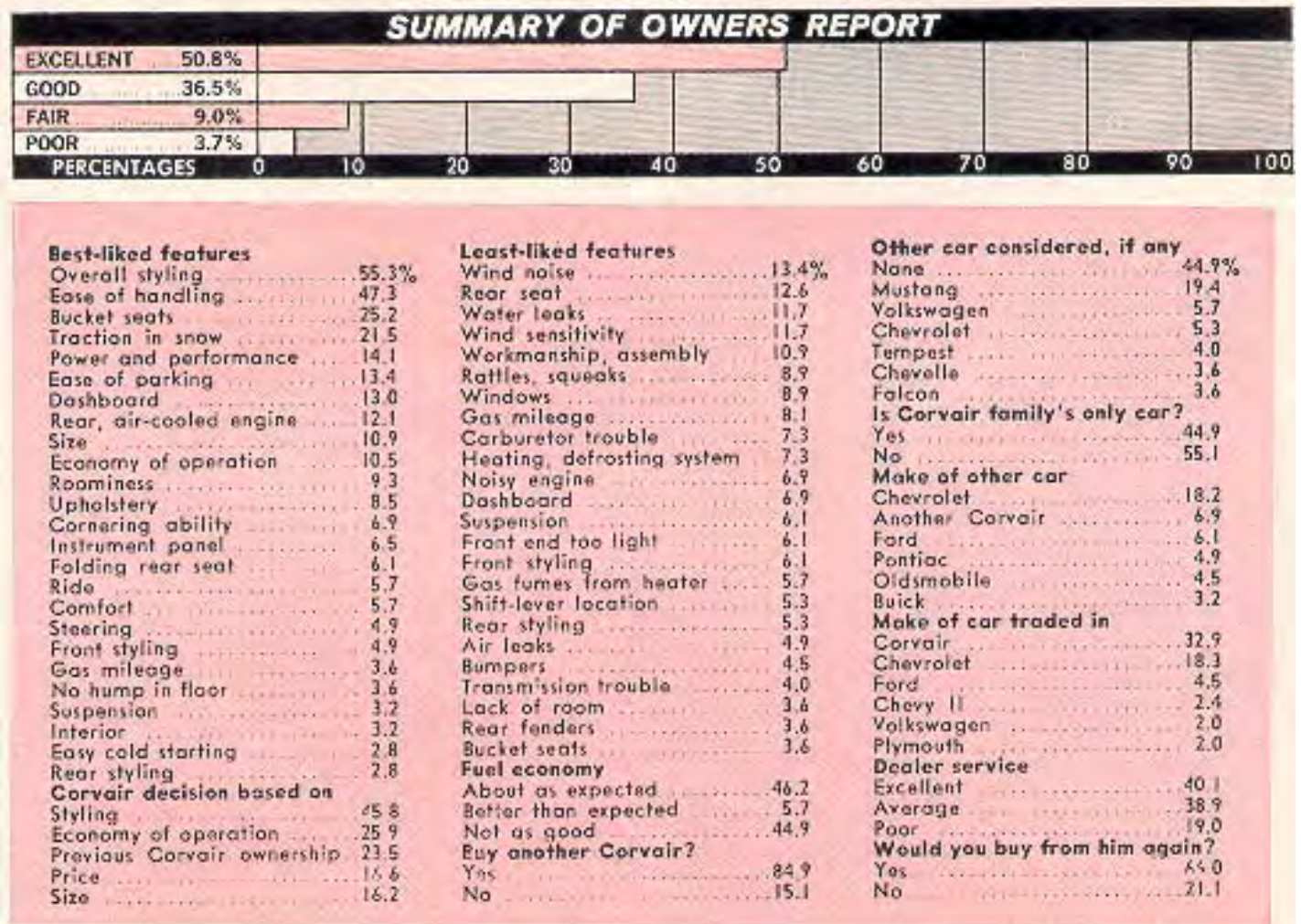

VCE Classifieds

1963 Corvair Van Complete, needs restoring, under 25,000 miles, located in Haleyville, AL. Truck sold new in B'ham; engine was running when I traded for it; no brakes, all air cleaner system intact, original T-3 headlights, spare tire hold down. Can deliver in AL for expenses. \$500.00 OBO Jerry Albright @205/486-9853

1964 Monza convertible Recent saddle bronze paint and white top. New WSW tires, wire caps, good brakes.

Floorboards have been cleaned, rustproofed, and primed. Underside cleaned and painted. Runs good. Was original factory air car. Have all parts to restore A/C. Needs new interior. \$3,400 OBO. Ed Keller (205) 823-5424

1964 Monza Convertible powerglide, 56,000 actual miles, garage kept, original interior, rust free car. Has been painted, new carpet and heavy duty top installed. extra nice car, \$7,500. Firm price. 205/640-6952

1964 Monza Convertible black interior and exterior, 4-speed, new paint, new bumpers, front trim, etc. Needs assembly and finishing, \$1,300. Ed Keller 205-785-5431 (D), 205-823-5424 (N)

1961 Lakewood 100s of parts. Also a '63 Corvair in good condition, runs good. Located near Decatur. Contact Sandra Staggs at n2junk@msn.com

64 Monza Coupe Original auto transmission, original 110HP engine, original factory interior, and 60,500 actual miles. Local car, original owner. Car has been re-painted once - stayed with original color (white). It resides in my shed out of most of the weather. Huntsville area. Call Ken Colburn at 256/837-2776 or email at ken_colburn@msn.com

Vulcan Corvair Enthusiasts, a chapter of the Corvair Society of America, is a non-profit club dedicated to the preservation and restoration of the Corvair automobile.

VCE dues of \$20/year pay for a family membership and 12 issues of the *Oil Drop* newsletter.

President: Ed Keller
205/823-5424

Vice President: Harold Hartline
205/491-5253

VP/Membership/Newsletter: Russell Noble
205/822-6092

Secretary: Joe Doughty
205/995-0131

Treasurer: John Hathaway
205/408-4063

Hospitality: Jon & Sarah Keeton
CEO of Enforcement: Jewel Hinkle

Web: <http://clubs.hemmings.com/vulcancorvair/>



Yours truly's '65 Corsa Convertible



Vulcan Corvair Enthusiasts
PO Box 59071
Birmingham, AL 35259-9071



Vairs gather for a VCE meeting

T
H
E

OIL DROP



THE OFFICIAL NEWSLETTER OF THE VULCAN CORVAIR ENTHUSIASTS Vol 22, No 10

October 2001

From the Prez

Well, let's hope the October meeting will let us return to normal at the regular room in the Vestavia library. We had to really improvise for the Sept. meeting, but everything worked out well. At the "Vairs at the Fair" get-together at Warner Robbins the weekend of Oct 5-6, we had ten members in attendance - The Hinkles, Hartlines, Smiths, Kellers, and the Siemens. The fair was fun, as usual, and we enjoyed visiting with our friends from other clubs. This is a nice drive through parts of Alabama and Georgia. We need to appoint a nominating committee for officers for the upcoming year, so please be available, if needed.

Ed

Cruise-In Locations (last month this year)

- 1st Fri Arby's - Moody
- 1st Sat Walmart - Hwy 31, Pelham
- 2nd Sat Burger King - Center Point Rd.
WalMart - Hwy 31, Clanton
- 3rd Sat Arby's - Trussville
- 4th Sat Walmart - Bessemer
Walmart - Sylacauga

Next Meeting:

Date: Friday, October 19th, 2001

Time: 7:00 PM

Place: Vestavia Hills Library on Hwy 31

Chris and Francis Rothe will be serving supper for the October meeting - be there!.

Calendar of Events

- Oct 13 Car Show - Benefit for American Cancer Society - Pelham Wal-Mart
- Oct 19-21 Fall Corvaire Affair - Charlotte, NC
- Oct 20 Car and Truck Show - Children's Hospital benefit - Arby's on Clay/Chalkville Road

2002

- Feb 14-15 Corvaire Lovers' Holiday - Navarre, FL
- Jun 26-29 CORSA Convention - Flagstaff, AZ

Welcome to New Member

Chris Nicholson has joined our club and is hoping to make some of the meetings in the future. Chris plays guitar with a group, and is frequently "booked" on Friday nights. He currently has a '64 Greenbrier (formerly owned by Ed Keller).

From the Editor

Well, *The Oil Drop* is in an abbreviated version this month. Too much going on, and not enough new stuff to fill the pages. I guess I need to be fired. Send me stuff for next month!

New Classified Ad:

1965 Monza Coupe: Black, auto, AM radio, 68K miles, \$2,500. Call Ellis Stanley. 205/663-4236



August Meeting Minutes

With approximately 35 members present, the meeting was opened at 7:00 PM at the Vestavia library beginning with a very enjoyable meal served by Elsie Pemberton and John Hathaway. Following the meal the membership gave Elsie and John a big hand for a job well done

Following the completion of the meal the business meeting was called to order starting with a report by Treasurer, John Hathaway, stating that as of August 17th, 2001 we had a balance in our bank account of \$561.85.

President Ed Keller reported on various upcoming car shows and events.

Bob Siemens stated that a joint outing was scheduled on September 29 with the North Alabama Chapter for a tour of the Mercedes assembly plant at Vance and all members are invited to attend.

Russell Noble put on a computer controlled slide show of cars and events from the recent CORSA International Convention held at Chicago. (photos courtesy of Frank Ranelli and Chris Rothe - ed.) This was followed by a convention slide show put on by Harold Hartline of both the Daytona and Chicago conventions.

It was announced that at the September meeting the meal will be served by Harold Hartline and grandson, Brannon.

The meeting was then adjourned.

Submitted by Joe Doughty, Secretary

Convention Photos

For those of you that missed the great slide shows at the last meeting, here are a few selected photos. Thanks to Frank Ranelli for providing the digital shots...



A nicely done LM pickup



Very sharp LM 4-door



Cool LM race car



EM w/AC - note condenser location!



Clean EM coupe



Stately Greenbrier

Product Warnings:

"Caution: The contents of this bottle should not be fed to fish." -- *On a bottle of shampoo for dogs.*

"For external use only!" -- *On a curling iron.*

"Warning: This product can burn eyes." -- *On a curling iron.*

"Do not use in shower." -- *On a hair dryer.*

"Do not use while sleeping." -- *On a hair dryer.*

What New Owners Thought...

Here is a survey from the May 1965 Popular Mechanics magazine that polled '65 Corvair owners.

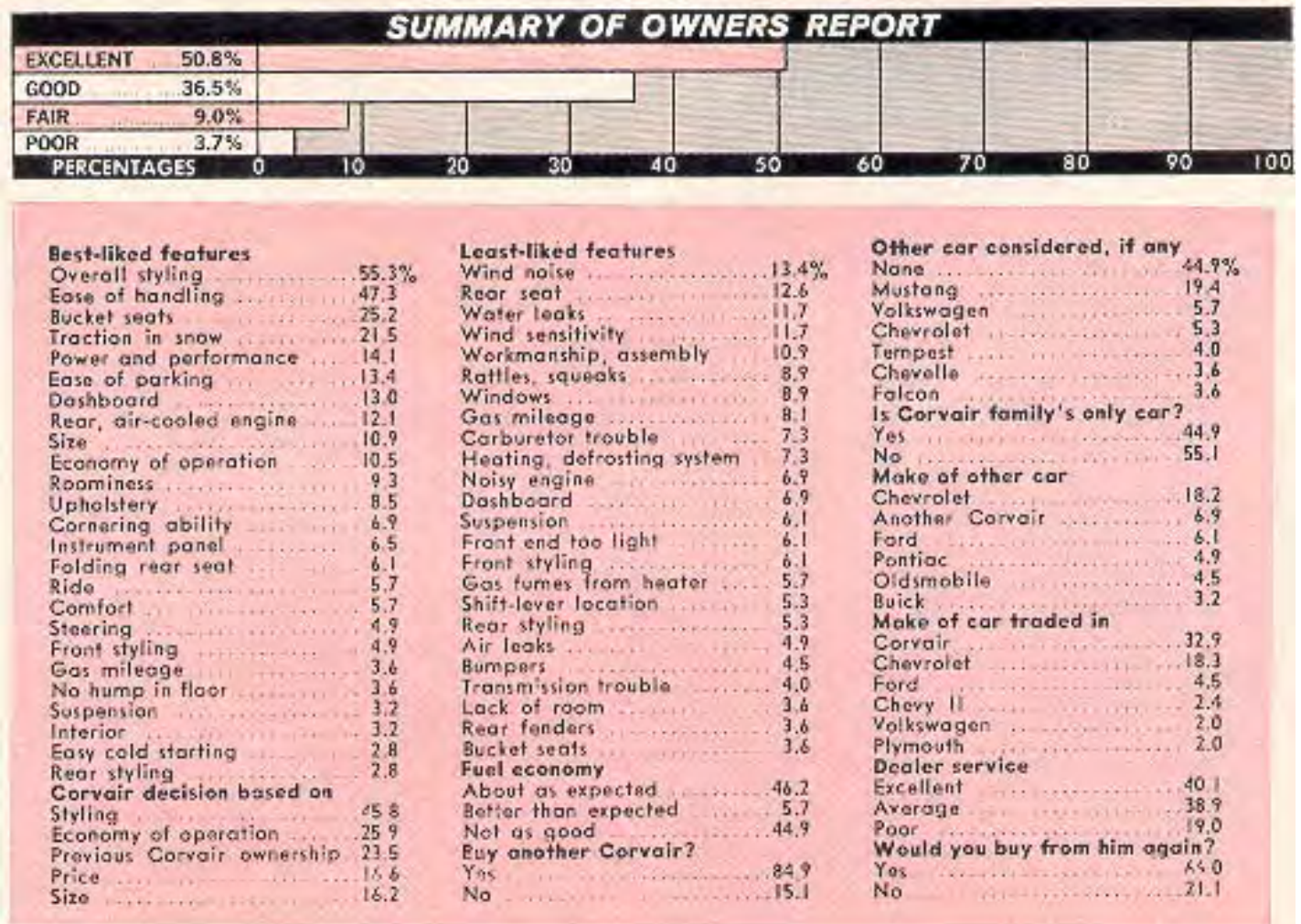

VCE Classifieds

1963 Corvair Van Complete, needs restoring, under 25,000 miles, located in Haleyville, AL. Truck sold new in B'ham; engine was running when I traded for it; no brakes, all air cleaner system intact, original T-3 headlights, spare tire hold down. Can deliver in AL for expenses. \$500.00 OBO Jerry Albright @205/486-9853

1964 Monza convertible Recent saddle bronze paint and white top. New WSW tires, wire caps, good brakes.

Floorboards have been cleaned, rustproofed, and primed. Underside cleaned and painted. Runs good. Was original factory air car. Have all parts to restore A/C. Needs new interior. \$3,400 OBO. Ed Keller (205) 823-5424

1964 Monza Convertible powerglide, 56,000 actual miles, garage kept, original interior, rust free car. Has been painted, new carpet and heavy duty top installed. extra nice car, \$7,500. Firm price. 205/640-6952

1964 Monza Convertible black interior and exterior, 4-speed, new paint, new bumpers, front trim, etc. Needs assembly and finishing, \$1,300. Ed Keller 205-785-5431 (D), 205-823-5424 (N)

1961 Lakewood 100s of parts. Also a '63 Corvair in good condition, runs good. Located near Decatur. Contact Sandra Staggs at n2junk@msn.com

64 Monza Coupe Original auto transmission, original 110HP engine, original factory interior, and 60,500 actual miles. Local car, original owner. Car has been re-painted once - stayed with original color (white). It resides in my shed out of most of the weather. Huntsville area. Call Ken Colburn at 256/837-2776 or email at ken_colburn@msn.com

Vulcan Corvair Enthusiasts, a chapter of the Corvair Society of America, is a non-profit club dedicated to the preservation and restoration of the Corvair automobile.

VCE dues of \$20/year pay for a family membership and 12 issues of the *Oil Drop* newsletter.

President: Ed Keller
205/823-5424

Vice President: Harold Hartline
205/491-5253

VP/Membership/Newsletter: Russell Noble
205/822-6092

Secretary: Joe Doughty
205/995-0131

Treasurer: John Hathaway
205/408-4063

Hospitality: Jon & Sarah Keeton

CEO of Enforcement: Jewel Hinkle

Web: <http://clubs.hemmings.com/vulcancorvair/>



Check out this Greenbriar!!!!



Vulcan Corvair Enthusiasts
PO Box 59071
Birmingham, AL 35259-9071



Does this look familiar?

T
H
E

OIL DROP



THE OFFICIAL NEWSLETTER OF THE VULCAN CORVAIR ENTHUSIASTS Vol 22, No 11

November 2001

From the Prez

Well it is time again to install new club officers for 2002. Harold Hartline, Russell Noble and Jon Keeton are graciously serving on the nominating committee to come up with some names to inject new blood into the VCE president and other club slots. Feel free to be a 'write-in' candidate if the nominating committee overlooks you.

The Christmas party has been scheduled for Friday night, 12/7 and will be held at the regular meeting location at the Vestavia Library. Be prepared to discuss party details at the upcoming meeting. See you at the meeting.

Ed

Next Meeting:

Date: Friday, November 16th, 2001

Time: 7:00 PM

Place: Vestavia Hills Library on Hwy 31

A super Vair supper has been planned by an anonymous party and the meal is 'guaranteed' to please. The menu is unknown and is being kept under wraps very tightly. Efforts to obtain information on servers and edibles were unsuccessful. BE THERE!

Calendar of Events

There were no submittals for any upcoming events in 2001.

2002

Feb 14-15 Corvaair Lovers' Holiday - Navarre, FL

Jun 26-29 CORSA Convention - Flagstaff, AZ

Cheaha Park Update

Someone asked a while back about the VCE meeting at Cheaha in the past. Well, Samantha Smith (Frank Ranelli's daughter) checked into the changes at Cheaha and found out that they are (or will) be renovating the park. Cabins and the main Lodge will receive a facelift. The makeover should be complete by summer 2002 and the park will begin taking reservations for the new facilities in June 2002. Thanks for looking into this Samantha!

Cars Available...

Bobby Avery (205-956-3930) is getting out of Corvairs. He has several cars located in Hamilton, Alabama that he is ready to let loose. Not clear on any prices, but sounds like he is ready for them to go. All cars have been resting peacefully in a metal building:

65 Turbo coupe

LM 4dr w/140Hp

Spyder convertible

64 coupe w/140Hp

64 coupe w/AC

EM convertible (says best in the bunch)

140 engine and other misc. parts

I was thinking about running up there and checking it out. Any riders out there?

Russell



More Fan Belt Discussion...

A warning if you've been using wrapped belts and switch to a non-wrapped type:

The fabric wrapping of the old type belts picks up a fair amount of dust and wears a little pattern about halfway down the pulley "V" groove. This leaves a high spot on either side of where the worn area ends, and when you switch to the non-wrapped kind, often the high spot hits about where the cords are in the new belt. The result is fairly rapid destruction of a couple raw edge belts (which are usually wider as well) at ever increasing intervals until the high spot gets polished off. Typical would be one breaks at 400 miles, second at 5000, and third at 15,000 and the fourth lasts forever. Don't be too discouraged if the first few tend to break a bit early, that stops as the pulleys break in. This problem will of course vary with the degree of wear on a given car. Haven't really felt there is any surefire way to restore the pulley grooves, I have a few belts to burn anyhow. One thing that does seem to help is letting a new belt break in for 20 minutes idling once it is tensioned before you go anywhere. I set tension fairly tight, generally just enough the alternator pulley can't be turned.

Most 11A1420 belts are a pretty good fit on a Corvair.

Incidentally, I have never found the belt guides made the slightest difference, I remove the idler pulley one and move the turkey roaster one out of the way. Makes service a little easier, especially if you do have a belt break sometime.

I miss the GM belts but they're all so old now its doubtful any would last long. They were all that would live with the 5800 rpm full throttle upshifts in my '67 140HP Powerglide.

Editor: I found this on the Web. Interesting stuff. Groves, belt guides, and the point on belt tension. Most sources recommend tensioning until the alternator pulley can just be moved by hand.



VCE Classifieds

1963 Corvair Van Complete, needs restoring, under 25,000 miles, located in Haleyville, AL. Truck sold new in B'ham; engine was running when I traded for it; no brakes, all air cleaner system intact, original T-3 headlights, spare tire hold down. Can deliver in AL for expenses. \$500.00 OBO Jerry Albright @205/486-9853

1964 Monza convertible Recent saddle bronze paint and white top. New WSW tires, wire caps, good brakes. Floorboards have been cleaned, rustproofed, and primed. Underside cleaned and painted. Runs good. Was original factory air car. Have all parts to restore A/C. Needs new interior. \$3,400 OBO. Ed Keller (205) 823-5424

1964 Monza Convertible powerglide, 56,000 actual miles, garage kept, original interior, rust free car. Has been painted, new carpet and heavy duty top installed. extra nice car, \$7,500. Firm price. 205/640-6952

1964 Monza Convertible black interior and exterior, 4-speed, new paint, new bumpers, front trim, etc. Needs assembly and finishing, \$1,300. Ed Keller 205-785-5431 (D), 205-823-5424 (N)

1961 Lakewood 100s of parts. Also a '63 Corvair in good condition, runs good. Located near Decatur. Contact Sandra Staggs at n2junk@msn.com

64 Monza Coupe Original auto trans, orig 110HP engine, orig factory interior, 60,500 actual miles. Local car, orig owner. Re-painted once - orig color (white). Resides in my shed out of the weather. Huntsville area. Ken Colburn: 256/837-2776 email: ken_colburn@msn.com

1965 Monza Coupe Black, auto, AM radio, 68K miles, \$2,500. Call Ellis Stanley.205/663-4236

The Latest ACTIVE Member List - 11/01

Peggy Bagby
8177 Cedar Mountain Rd
Pinson, AL 35126
205-681-7014

Walt & Marilyn Davison
156 Summer Place Lane
Sylacauga, AL 35150
256-245-9728

Mike Donley
8 Hibiscus Drive
Montgomery, AL 36109
334-272-7793

Joe & Rozelle Doughty
324 North Lake Road
Birmingham, AL 35242
205-995-0131

Charlie & Marie Drake
6454 New Castle Road
Morris, AL 35116
205-681-7143

Curtis Hare
3707 Havenview Circle
Birmingham, AL 35216
205-823-2165

Harold & Louise Hartline
1920 Longview Drive
Hueytown, AL 35023
205-491-5253

Phil & Carol Hartline
905 Echo Trail
Warrior, AL 35180
205-590-0141

John Hathaway
1406 Highland Lakes Trail
Birmingham, AL 35242
205-408-4063

Buck & Jewell Hinkle
4142 Terrace R West
Birmingham, AL 35208
205-780-0549

Mickey & Robin Hunter
1415 Chadwell St. S.W.
Decatur, AL 35601
256-306-0435

Jon & Sarah Keeton
2008 Elkwood Drive
Fultondale, AL 35068
205-841-5169

Ed & Carol Keller
2461 Jannebo Road
Birmingham, AL 35216
205-823-5424

David & Amy Langner
113 Munger Circle
Trussville, AL 35173
205-655-9445

George & Ann Miljus
722 Park Ridge Circle
Birmingham, AL 35242

Owen & Joyce Miller
601 Avondale Road
Montgomery, AL 36109
334-272-7085

Chris Nicholson
2406 Quail Ct
Birmingham, AL 35216

Russell & Debbie Noble
3416 Danner Circle
Birmingham, AL 35243
205-822-6092

Joseph & Carol Popinski
212 Maple Trace
Birmingham, AL 35244
205-978-1780

Frank Ranelli
1725 Hendrix Drive
Birmingham, AL 35214
205-798-3787

Norman Rodgers
408 South Broad Street
Albertville, AL 35211
205-878-1810

Chris & Francis Rothe
104 Gardenia Circle
Pleasant Grove, AL 35127
205-744-2072

Bob & Wilma Siemens
1725 Buck Island Drive
Guntersville, AL 35976
205-582-2175

Jerry & Sarah Smith
595 Browning Road
Odenville, AL 35120
205-640-6952

Mary Snead
4427 Ridgewood Rd East
Tuscaloosa, AL 35404
205-553-4210

Floyd T. Snider
4960 Big Oak Drive
Southside, AL 35907

Joe & Ann Steadman
1629 Arrowhead Road
Jasper, AL 35504
205-384-9576

Richard & Sandy Stolzmann
376 Burgess Drive
Springville, AL 35146
205-467-6444

Charles & Jan Trotter
102 Allen Road
Pell City, AL 35125
205-338-6828

Hugh & Sara White
1411 Gonzales Street
Pensacola, FL 32510
904-432-5974

Dick & Barbara Witkos
3112 Clayburne Road
Dothan, AL 36303
334-792-8528

Your Name Here
777 Anytown, USA
BR-549

VCE Email Addresses

This is the latest list of email addresses on record for the club. Please check yours and if incorrect, email me at rtnoble@southernco.com so I can fix it. (I think the Stolzmann's may be wrong) Also, if you now have email and you are not on the list, send me a note. Thanks!

Donley m_donley@knology.net
Keller ckell1218@mindspring.com
Nicholson censport@juno.com
Ranelli vair3@Bellsouth.net
Siemens rsiemens@charter.net
Stolzmann richeyrich43@hotmail.com

Keeton cudaman@prodigy.net
Miller RetiredCouple@Juno.com
Noble rtnoble@southernco.com
Rothe kt4ys@worldnet.att.net
Sarah Smith sarah.smith7@worldnet.att.net
Trotter jantrott@gte.net

Vulcan Corvair Enthusiasts, a chapter of the Corvair Society of America, is a non-profit club dedicated to the preservation and restoration of the Corvair automobile.

VCE dues of \$20/year pay for a family membership and 12 issues of the *Oil Drop* newsletter.

President: Ed Keller

205/823-5424

Vice President: Harold Hartline

205/491-5253

VP/Membership/Newsletter: Russell Noble

205/822-6092

Secretary: Joe Doughty

205/995-0131

Treasurer: John Hathaway

205/408-4063

Hospitality: Jon & Sarah Keeton

CEO of Enforcement: Jewel Hinkle

Web: <http://clubs.hemmings.com/vulcancorvair/>

CAR INVOICE						CHEVROLET		CADILLAC	
DART CHEVROLET - CADILLAC						15 S. Water St. Telephone 588-6600		No. X 16204	
"OK Friends"						SOLD TO: <i>John H. Gould</i>		DATE: <i>Aug 31, 1965</i>	
SALESMAN: <i>Bob Williams</i>						ADDRESS: <i>Jamesstown, Pa</i>			
MAKE	MODEL	YEAR	SERIAL NO.	ENGINE NO.	KEY NO.	<i>P. Red + Red trim</i>			
1965	537 Monza	N	105375W	Ign 9177	Engg 8911	PRICE OF CAR	2350.20		
<i>Corvair Sport Coupe</i>						OPTIONAL EQUIP. & ACCESS.	102.65		
						FREIGHT AND HANDLING	2452.85		
INSURANCE COVERAGE INCLUDES									
<input type="checkbox"/> FIRE AND THEFT					<input type="checkbox"/> PUBLIC LIABILITY — AMT.				
<input type="checkbox"/> COLLISION — AMT. DEDUCT					<input type="checkbox"/> PROPERTY DAMAGE — AMT.				
OPTIONAL EQUIPMENT AND ACCESSORIES									
GROUP	DESCRIPTION				PRICE				
	<i>110 H.P. engine</i>				<i>26.30</i>				
	<i>Manual radio</i>				<i>48.95</i>				
	<i>Comfort + Convenience eqt</i>				<i>27.40</i>				
<i>New Car Warranty</i>									
<i>24000 Miles or 24 Months</i>									
<i>whichever expires first.</i>									
<i>at Dart Chevrolet.</i>									
<i>State Auto Ins</i>									
<i>Chance Associates</i>									
<i>Etna, Pa</i>									
<i>First payment Oct 15-4</i>									
						<i>allowance 1652.85</i>			
						<i>MAC payoff 685.56</i>			
						<i>Net allowance 967.29</i>			
						CASH ON DELIVERY	967.29		
						USED CAR	<i>65 Corvair</i>		
						TYPE	<i>Monza Coupe</i>		
						SER. NO.	<i>(1406)</i>		
						END. NO.	<i>AMAC</i>		
						PAYMENTS	<i>36 @ 50.84</i>		
						TOTAL	2498.85		
59 -						ALWAYS SHOW SERIAL ENGINE AND KEY NUMBERS 6N			

\$2498.85 for a new 1965 Monza Sport Coupe!



Vulcan Corvair Enthusiasts
PO Box 59071
Birmingham, AL 35259-9071



Bad Bushing?

T
H
E

OIL DROP



THE OFFICIAL NEWSLETTER OF THE VULCAN CORVAIR ENTHUSIASTS Vol 22, No 12

December 2001

******Christmas Party Notice******

NOTE: No Regular Meeting in December!!!

The VCE Christmas party is scheduled for an informal 6:00PM or so start on 12/7/01 at the Vestavia library location. Contact Jewel Hinkle at (205)780-0549 if you want to ask a question about what to bring, gifts, etc. Please keep gifts under \$15.

Nominating Committee Update:

All officer slots are filled except for VCE President. If you are willing to serve in 2002, contact Russell Noble at (205)822-6092 or Harold Hartline at (205)491-5253.

From the Outgoing Editor:

Two years have flown by and the *Oil Drop* baton will be passed over to Mike Donley in 2002. Good luck, Mike. Russell

November Meeting Minutes

The meeting was held at 7:00 PM at the Vestavia library where we were served a delicious meal furnished by Harold Hartline and several of our lady members.

After the meal President Ed Keller called the business meeting to order and asked for a treasurer's report.

Treasurer, John Hathaway, reported that we started as of 10/19/01 with a bank balance of \$387.24. Since that date we have received \$16, spent \$53.75 and paid bank charges of \$3.85 leaving a balance as of 11/16/01 of \$345.64.

November Meeting Minutes (con'd)

There being no old business outstanding, President Keller called for any new business.

Russell Noble reported on the efforts to-date of the nominating committee. He stated that they had done a lot of work but as of this date had not rounded out the slate of officers they will recommend for election by the membership.

President Keller reminded members that the Club Christmas party will be held on Friday 11/7/01 at the Vestavia library at 6:00 PM. He asked that each lady bring a lady's gift of about \$10-\$15 and each man and man's gift of the same value.

Jewel Hinkle reported on the food for the Christmas party and stated that the club would furnish the meat which will be ham and turkey and she assigned various dishes and other items to specific members to be brought to the party.

It was announced that the yearly "Mid Winter Corvaire Retreat" would again be held in January, 2002 in Pigeon Forge.

President Keller reported that a man named Ray Turner has a lot of parts Corvairs in Dothan. He also stated that the classified ad section of the *Oil Drop* was working well and that he thought we should continue it.

Walt Davison announced that he would hold a short tech session on carburetors after adjournment.

On motion by John Hathaway, seconded by Russell Noble, the meeting was adjourned.

Joe Doughty
Secretary

Calendar of Events

2002

Feb 14-15 Corvaire Lovers' Holiday - Navarre, FL

Jun 26-29 CORSA Convention - Flagstaff, AZ

