



THE OFFICIAL NEWSLETTER OF THE VULCAN CORVAIR ENTHUSIASTS Vol 35, No 1

January 2014



THE PRESIDENT’S COLUMN:

Well it's almost the end of 2013. We had our last meeting at Russ's house in conjunction with our annual Christmas Party. Russ graciously provided his home for this purpose and the delicious food. The rest of us brought drinks and deserts. We had approximately 31 members attending. We all had a good time eating and swapping stories. Russ took us out to his shop and showed us the motor he rebuilt for George Miljus, he even cranked it up and ran it for us.

On a special note, as we usually do we took up a collection at the Christmas Party for a charitable organization, but this year it was given to our newsletter editor’s son in law, Derick Williams who is battling liver cancer. Our prayers are with him as he fights this dreadful disease. Also, we voted to continue with our current slate of officers for 2014. We also voted to put a little fun in our meetings. For those who want to participate, we are going to ask each member to donate \$1.00 to put in a pot. Each member will get a ticket for the drawing and at the end of the meeting someone will go home with gas money.

Don't forget club dues of \$20.00 are due in January.

REFLECTIONS FROM THE SEAT OF AN OLD TRACTOR

“You can’t ‘unsay’ a cruel word.”

Next Meeting:

Date: FRIDAY, JANUARY 17, 2014

Time: 7:00 pm

Place: FULLNESS CHRISTIAN FELLOWSHIP



In This Issue:

Upcoming Events and MTG Minutes.....(2)
 Corvaire Calendar and OD Archives.....(3)
 VCE Christmas Party.....(4)
 Christmas Party (cont.).....(5)
 Blast from The Past.....(6)
 Classifieds.....(7)

Web Links 4 U!

Corvaire Center Forum

‘Encouraging the Preservation and Enjoyment of the Corvaire’

<http://corvairecenter.com/index.php>

Upcoming Events!

January 10-12, 2014 Winter Retreat

Pigeon Forge, TN, At Best Western Toni Inn, 3810 Parkway, Highway 441, Pigeon Forge TN, \$44 plus tax, 865/453-9058, mention you are with East Tennessee Corvair Club to get discount. Jean Bates, 423/245-2723, ajkbates@gmail.com.

Feb. 21-22 Corvair Lover's Holiday

Pensacola, FL. Days Inn Pensacola Beachfront 16 Via De Luna, Pensacola Beach, FL. 850-934-3300 Mention Corvair for \$69 or \$89 gulf side rates. Dinners Friday and Saturday, door prizes, 50/50, Valve Cover races, Ladies Get Together. Vendors welcome outside. Contact June Lindsay @ wfcc@mediacombb.net or 850-994-2161

April 18-19 Springfest, Helen Ga.

Hosted by Corvair Atlanta, Heart of Georgia Corvairs, Queen City Corvair Club. Autocross and hospitality party on Friday. Saturday concours, people's choice, valve cover races, and more. Clark's Corvair Parts will be attending. Host Helendorf River End, 706/878-2271, \$89 per night, two nights minimum for riverside, \$69 per night for standard; Best Western 800/435-3642, \$69 standard, \$89 suites; Super 8, 800/535-1251, \$55. Make reservations before March 15. Lillian Law, lawjandl@aol.com, 229/883-4123, cell 229/291-0567.

July 21-25, 2014 CORSA International Convention,

Tacoma, WA.

Hosted by 'Corvanatics'. Join us for "Corvair Expo" where the LeMay Automobile Museum will be the center of convention events as well as displays and activities celebrating the Corvair. Host hotel is Hotel Murano in Tacoma, 888/862-3255, mention "Corvairs" or "CORSA" for special \$109 room rate, reserve online at: https://resweb.passkey.com/Resweb.do?mode=welcme_ei_new&eventID=10747152

December 2013 VCE Party and Meeting Minutes

The December meeting of the Vulcan Corvair Enthusiasts was held on Saturday, December 14th at the home of Russ Thuleen. Thirty-one members were in attendance for the meeting and Christmas party.

Business matters covered the collection of money for the club t-shirts, dues for 2014 and our annual charity collection which was given to Billy and Judi Cannon's son-in-law for medical/household expenses during his illness. Holding a 50/50 drawing at each meeting was discussed and voted on. This will be initiated during the January meeting.

A party for the 4th of July was discussed. The idea was to get the members out for more than just meeting and once a year party and to socialize with other clubs in surrounding areas (i.e. Tennessee and Georgia)

All 12 issues of the 2013 Oil Drop were displayed and voted on by those in attendance. The results of the vote will be submitted to the CORSA office for the Tony Fiore Memorial CORSA Chapter Newsletter Award contest.

After the members socialized and had a delicious meal from Johnny Ray's, Russ held a tech session showing the various projects going on in the garage. The engine he and George Miljus have been rebuilding was started up while on the work bench.

Pics of the Christmas Party are located on Page #4 and throughout this issue

Send Oil Drop submissions to:

GTOChief@gmail.com

Office: 256-839-1905

Cell: 256-404-5998

NOTE: PLEASE SEND SUBMISSIONS NO LATER THAN THE 25TH OF THE MONTH.

Corvair Calendar:

John Cleveland recently purchased a 2014 calendar published by the Detroit Area Corvair Club. It is very well done and has a lot of pictures of Corvairs from their 2013 Homecoming show. For \$12 it is well worth it. \$2 of that covers shipping. It was delivered within a week after he ordered with PayPal.

To view a sample of the calendar go to <http://www.allesee.com/calendar/>. You can order there also by check (with a printed form), or by PayPal.

Oil Drop Archives (also from John)



John's Monza and Billy's Corsa all decked out for Christmas

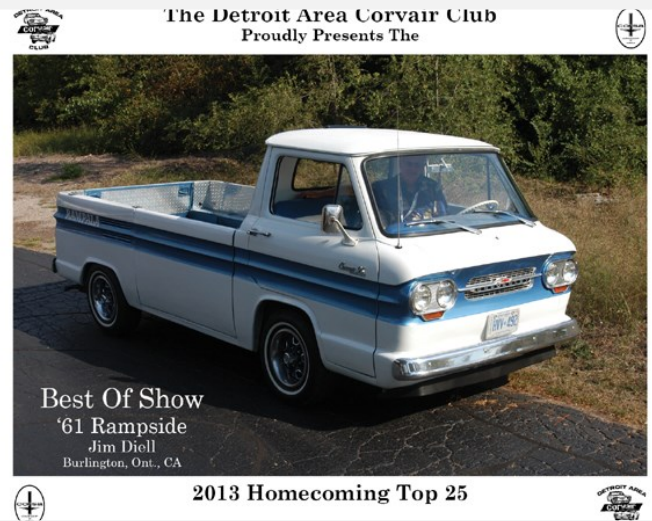

Since I forgot to bring the newsletter CDs to the Christmas Party, please show up at the January meeting to get one, or email me at monzajohn@charter.net and I'll send you one. These are all the newsletters I could find since the clubs beginning in June 1974. The collection has bet-



'Shorty' leads the way at the Chelsea, Alabama Christmas Parade



Christmas Party 2013

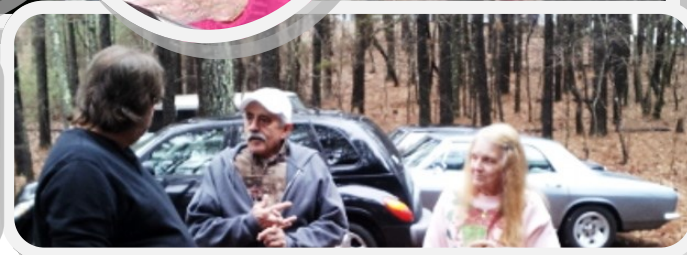

Christmas Party 2013 (cont.)

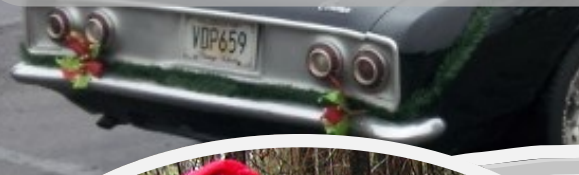

Vulcan Corvair Enthusiasts



Birmingham, Alabama

Corsa Chapter. 352

Blast from the Past! 40 Years of the Vulcan Corvair Enthusiasts

The January 1975 VCE newsletter has the first published membership roster. There was a roster given to the members at the October meeting but a copy of that one hasn't been found. In September, 1974 there were 28 members according to the September newsletter. The first item in the January 1975 issue states there were 34 members. The following is a list of members printed in that newsletter:

Butch Baldone	W. Bill Ennis	Dave Holder
Sam Johnston	James Parker	Frank Ranelli
James Ray	Pat Rooney	Beverly Striplin
Dean Koch	Harold Hartline	Butch Wadsworth
Richard Stolzmann	Neil Patterson	Norman Rogers
Bill Mitchum	Bill Raybon	Charles A. Smith
Johnie Hill, Jr.	Don Godfrey	Bill Dowling
David Bibby	Lee Miller	

Dues in 1975 were \$4.00 a person or \$5.00 for a family and there was some discussion about a rummage or bake sale to raise money for club decals. The club was also helping to raise money for a young girl who was facing a kidney transplant.

The club ran a 'Corvair Hotline' which was advertised in the Birmingham Post-Herald.

"Corvair Hotline: For those who own the automobile which, along with Ralph Nader, brought the consumer movement to the headlines, there is now a hotline which offers help in obtaining parts and service. Formed by the Vulcan Corvair Enthusiasts – a chapter of the Corvair Society of America – the hotline also serves as an outlet for those wishing to sell parts, or a Corvair itself, at reasonable prices. If you have a Corvair and need help with repairs at reasonable fees, call the hotline at 798-4391. It's faster than Nader."

The club was also busy preparing for the 1975 CORSA mini Convention.



CLASSIFIEDS

Al and Paula Hilderbrand

from Corvair Atlanta and Heart of Georgia
Have placed these two beauties up for sale:

1961 Corvair Monza 700

Believe it's the original 85hp / PowerGlide
Hounds tooth (2tone) interior
New (\$800) Tires, Runs Good
\$3900 770-974-3283



1965 Corvair Corsa Street legal Race Car

Is set-up to race, but is registered in GA and street driven.
Features: two racing seats with 5 point harnesses
Rollbar, Stock Suspension, 140+hp motor mostly stock:
Mods:electric fuel pump, fuel pressure regulator, Fuel cell,
Ignitor II (no points), FlameThrower (45K) coil,
14" Olds wheels and BF Goodrich AT Radials tires,
Decals are removable, 4spd trans w/Quik shift
Parts have been removed but nothing that can't be put back.
Car looks good, runs great and fast.
\$4500 770-974-3283



Vulcan Corvair Enthusiasts, a chapter of the Corvair Society of America, is a non-profit club dedicated to the preservation and restoration of the Corvair automobile.

VCE dues of \$20/year pay for a family membership and 12 issues of the Oil Drop Newsletter.

President: Richard Stolzmann 205/467-6444 Vice President: Pete Wood 205/956-6832 Secretary: Russ Thuleen 205/678-7979 Newsletter Editor: Billy Cannon 256/839-1905 Treasurer: Joe Doughty 205/995-0131

Hospitality: Harold Hartline Arrangements: Judi Cannon



THE OFFICIAL NEWSLETTER OF THE VULCAN CORVAIR ENTHUSIASTS Vol 35, No 2

February 2014



THE PRESIDENT'S COLUMN:

First thing I have to do is inform all members of a good friend and VCE members passing, Hoyt Mann. After successful by-pass surgery Hoyt died 18 hours later due to complications. Our sympathy and prayers go out to his relatives. We will miss him! (Tribute on page 2)

At our first meeting of 2014, Pete Woods got the lucky ticket for our very 1st gasoline drawing. We had around 25 members present, even though it was really cold outside. As usual we had plenty of good eats at our monthly potluck supper. Next thing coming up is the Pensacola 'fun in the sun' function. We have lots of members that plan on attending, so we voted to have our monthly meeting an hour before the awards banquet in Pensacola. We have a few members going down a day early, so let me know if you want to join our caravan down there. We usually meet on I65 south of Birmingham.

Russel Noble has reported that our 40th anniversary shirts that we ordered will be available at the next meeting. I suppose we will have to pick them up during the March meeting, as we will be in Pensacola in February.

REFLECTIONS FROM THE SEAT OF AN OLD TRACTOR

"Don't interfere with something that ain't bothering you none."

Next Meeting:

Date: Saturday, February 22, 2014
 Time: To Be Determined (1 hr. before banquet)
 Place: Days Inn, Pensacola, Fl

In This Issue:

Hoyt Mann Tribute.....	(2)
Upcoming Events & Meeting Minutes.....	(3)
Tech Tip (Dual MC Conversion).....	(4)
Performance Ads.....	(5)
Blast from The Past.....	(6&7)
Classifieds.....	(7&8)

Web Links 4 U!

As discussed during the January Meeting:

List of Ethanol-Free Gas Stations
 According to the website there are 357 Pure Gas Stations in Alabama:

pure-gas.org



Hoyt L. Mann

Mar. 21 1943 - Jan. 20 2014



Mr. Hoyt Lee Mann of Talladega, AL went to be with the Lord Monday, January 20, 2014 at Trinity Hospital in Birmingham, AL. Funeral services were held 2:00pm Thursday, January 23, 2014 in Opelika, AL. VCE members Harold and Louise Hartline, Ed and Carol Keller and Russ Thuleen were present to offer their and the club's condolences. Hoyt was buried at Garden Hills Cemetery, Opelika and is survived by his wife, Janet; his daughter, Mari Lee; his step son, Craig; and his grandchildren: Katlyne, Chase, and Ashlynn Roddam. Hoyt was a native of Georgia but moved to Opelika as a baby where he lived to the age of fourteen. As a young man he got into law enforcement where he served as Chief of police in several towns, and attended the FBI Academy. His last job was with the Talladega Sheriff's Department where he retired in 2009. Hoyt and Janet served as foster parents to over a hundred children.



Your life was one of thoughtful deeds,
A helping hand to others needs,
Sincere and true in heart and mind,
Wonderful memories you left behind.



Upcoming Events!

Feb. 21-22 Corvair Lover's Holiday

Pensacola, FL. Days Inn Pensacola Beachfront
16 Via De Luna, Pensacola Beach, FL. 850-934-3300
Mention Corvair for \$69 or \$89 gulf side rates.
Dinners Friday and Saturday, door prizes, 50/50,
Valve Cover races, Ladies Get Together. Vendors
welcome outside. Contact June Lindsay @
wfcc@mediacombb.net or 850-994-2161

March 7-9 Spring Warm-Up

Myrtle Beach SC. Central Carolina CORSA
Car show, hospitality, valve cover race, Bingo, poker/
scavenger hunt, and swap meet. Vendors free with
show registration.
Sea Mist Resort, 1200 S. Ocean Blvd.,
Myrtle Beach SC, 800/732-6478, mention 846171 for
special rates until February 10th.
Jerry Brown, 4049 Liberty Church Rd.,
Manning SC 29102, 803/225-0005

April 18-19 Springfest, Helen Ga.

Hosted by Corvair Atlanta, Heart of Georgia Cor-
vairs, Queen City Corvair Club.
Autocross and hospitality party on Friday. Saturday
concours, people's choice, valve cover races, and
more. Clark's Corvair Parts will be attending. Host
Helendorf River End, 706/878-2271, \$89 per night,
two nights minimum for riverside, \$69 per night for
standard; Best Western 800/435-3642, \$69 standard,
\$89 suites; Super 8, 800/535-1251, \$55. Make reser-
vations before March 15. Lillian Law,
lawjandl@aol.com, 229/883-4123, cell 229/291-0567.

July 21-25, 2014 CORSA International Conven- tion, Tacoma, WA.

Hosted by 'Corvanatics'. Join us for "Corvair Expo"
where the LeMay Automobile Museum will be the
center of convention events as well as displays and
activities celebrating the Corvair. Host hotel is Hotel
Murano in Tacoma, 888/862-3255, mention



"Corvairs" or
CORSA" for spe-
cial \$109 room
rate.

January 2014 VCE Monthly Meeting Minutes

The first meeting of the new year was held on Jan-
uary 17th at Fullness Christian Fellowship with 25
members present. Treasurer Joe Doughty reported
that \$1,005 has been taken in for club shirts. Rus-
sell Noble went over the shirt list and will be plac-
ing the order Friday.

Billy Cannon discussed a possible 3 club Spring
Picnic event - more information to be given at a
later date. He also reported on a Wayne 100 Cor-
vair boat for sale on the west coast and made avail-
able copies of the U.S. Patents for the boat. If in-
terested see Billy for more information. Harold
Hartline talked about the show at Pigeon Forge and
several cars for sale. Steve Daniels reported on a
'63 Monza for sale. (See the 'Classified' pages for
more information).

Pete Wood won our first club drawing for a cash
stash of \$32. The February meeting will be held in
Pensacola on February 21st.



VCE President, Richard Stolzman's HIGH mileage, Been
Totaled at least TWICE, MONZA Coupe. Circa 2001
Photo Credit: Russell Noble

Send Oil Drop submissions to:

GTOChief@gmail.com

Office: 256-839-1905

Cell: 256-404-5998

**NOTE: PLEASE SEND SUBMISSIONS NO
LATER THAN THE 25TH OF THE MONTH.**

Tech Tip

Dual Master Cylinder Conversion

The Corvair Dual Master Cylinder (MC) system has that small steel 'block' just outside the MC, for the purpose (only) of turning on a light if and when one of the lines fails. AS I understand it, there is a diaphragm inside that 'block' that moves to one side or the other, to allow an electrical connection when this happens. This means that the foot pedal then cannot move far enough to provide adequate braking on the remaining working system. So, it seems to me the answer is to remove that 'block' and plumb straight into the usual dual lines. And, yes, there is a kit available to do just that. There is even a dual MC with outlets on the other side to make the job easier. On our Corvairs, if a rear line goes out, the front tires will lock up pretty easily;

if a front line goes out, the car will stop reasonably well. Just the reverse is true on a front engine car. The dual master set up requires that the brake shoes be adjusted properly for the system to work in failure mode. If your pedal travel is considerable when everything is working, you'll never get enough fluid displacement to create stopping pressure in the failure mode without, as you found out, rapid pumping of the pedal.

All that any "conversion kit" has will be the dual master cylinder, outlet port adapters, one or more brake lines, and a plug for the main distribution tee. Basically you remove the rear line out

of the distribution tee, plug the tee, then using a union and the new brake line, connect the rear line to one of the dual master cylinder outlet ports. The other outlet port is connected in the same way the original brake line to the master was; just that now it only works the front wheels. The only additional line involved is the one that runs from the end of the rear brake line to the new master cylinder.

When I disconnected the rear brake line from the firewall fitting and put an inverted flair plug in its place, I installed another 1/4 inch inverted flair tee fitting onto the rear brake line, right up against the original fitting, that I had just disconnected. I installed another inverted flair plug into the bottom hole. I drilled a 1/2 inch hole, 7/8 inches in back of the existing line and in line with it from front to back. Then I purchased two 1/4 x 12 inch brake lines and bent them to go from the existing and new fitting hole, going under the master cylinder and up to the ports with the adapters that are called out in the tech articles. This was a very easy job and could be reversed for any nut that wants to run with a single master cylinder. There was no trying to bend the rear brake line while laying on your back under the dash or trying to cut and double flair the line. This project used all standard fittings and lines that are available at any automotive parts store.

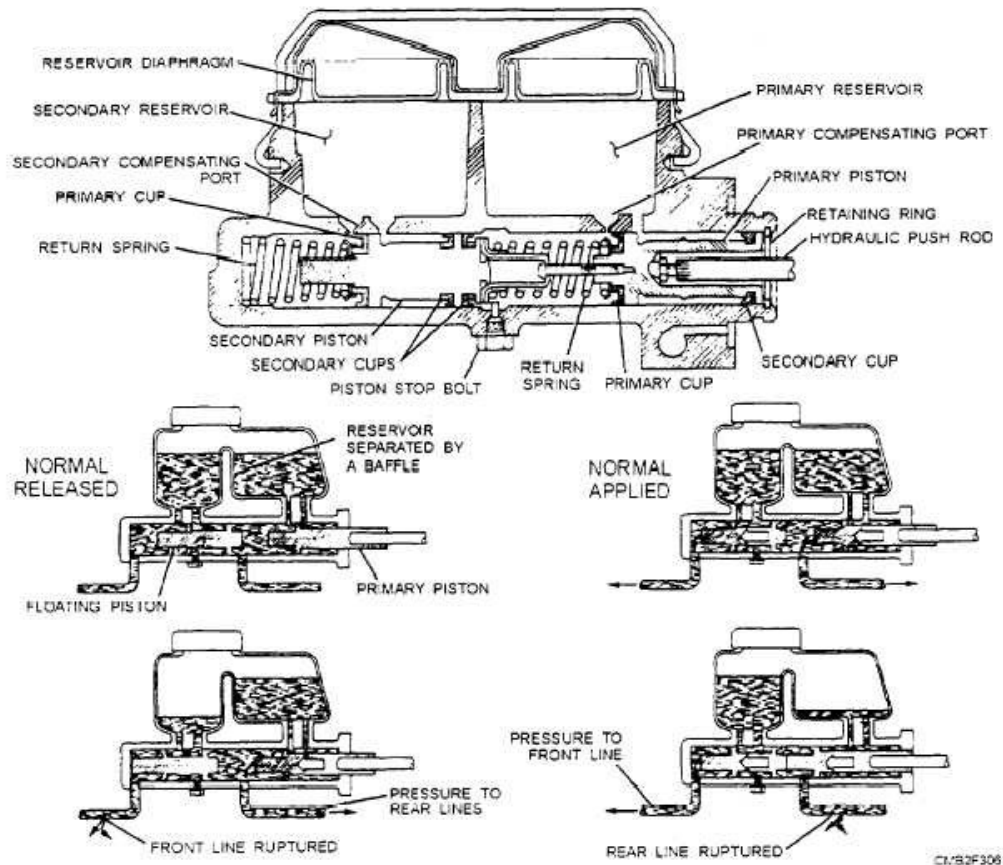



Corvair

Performance Ads of The 1960's

Custom Corvair panel send \$1.00 for info. and color photos. \$1.00 refund with purchase. Other compacts available soon. Panel without tachometer also available.

NORTH AMERICAN INSTRUMENT CO.
2224 West 5th Avenue #304
Gary, Indiana



VINYL SHIFT BOOTS
In authentic interior-matching colors for
CORVAIR MONZA

EASILY INSTALLED
Dress up your Monza/Corvair
Prevent grease from soiling clothes and car interior.
\$2.95 ppd.

PLASTIC RIM STEERING WHEEL, non-slip rim, chrome spokes and hub, croked, 15 1/2" dia. Horn assembly kit - \$16.50. Black, white or red, green, blue, silver or gold metallic.

GT SHIFT KNOB
Coneco "GT" wooden gearshift knob. The chip-resistant high-gloss finish on this hard maple knob will keep its new look for years. For all cars, specify make, model & year.....**\$2.95**

coneco 322 S. San Gabriel Blvd.
San Gabriel 15, Calif.

if you're the lucky owner of a
CORVAIR

THIS MESSAGE IS FOR YOU!
Newly engineered for all 60, 61 and 62 Corvairs (including the Spyder) — genuine Gold Seal Traction-Masters make a world of driving difference in these fine little cars. TM's will give you flat, smooth corners . . . end side sway . . . firm the rear end to insure solid "drag strip" starts . . . safety with performance. Clean arc-weld installation with precision fit.

only **42.45** per pair

And to add the cherry on the Corvair cake — put Traction-Master Nokofs on your wheels! Nokofs are the automotive world's most beautiful hubcaps.

Precision engineered of durable zamac, triple chromed spinners for elegance — these gleaming masterpieces give Corvair the authentic "working" sports car look!

set of 4
Bright Zinc Hubs.....**\$24.95**
Full Chrome Hubs ... **29.95**

Traction-Master Co.
2917 W. OLYMPIC BLVD. CL. LOS ANGELES 6, CALIF.



NO. 8-110 POLISHED ALUMINUM VALVE COVERS
These are a clean addition to the Corvair or Corvair powered dune buggy. Cast of heavy aluminum and polished to a high luster, they will truly enhance your engine. Their thickness will also quiet valve noise and create an excellent leak proof seal around the cover surface.

VALVE COVERS (1960 - 69, all) a pair **\$32.95**
VALVE COVER GASKETS (neoprene) .. a pair **\$ 2.75**

MORE SPUNK FOR YOUR SPYDER!!
WITH A DICK GRIFFIN CARBURETOR/MANIFOLD KIT
START YOUR TURBO WORKING AT 2600 RPM INSTEAD OF 3600 RPM
PRODUCE UP TO 34 MORE SNAPPY HP!

Complete Kit **\$79.95**
MER TOOL & DIE CO. P.O. BOX 478 LANSING MICHIGAN



NO. 8-503 TURBO-CHARGER MUFFLER
Give your turbo-charged Corvair some extra power. This bolt-on muffler increases boost pressure by 1.5 p.s.i. The extra pressure increases engine horsepower over the factory unit. It is ideal in combination with the number 8-502 Turbo Charger Induction manifold.

TURBO-CHARGER MUFFLER (1962-66) **\$19.95**

Blast from the Past! 40 Years of the Vulcan Corvair Enthusiasts



This is the header for the February 1975 edition of the VCE newsletter. There was much preparation for the mini convention happening in May.

Some news from Feb. 1975:

The weekend of Feb. 7, 8, and 9 will be a busy one for several of our members. James Ray, with the help of some of our members, will have six cars on display at the International Car Show in the Civic Center. Three of these will be his Corvair's including one that no one has ever seen. With these will be a poster announcing our convention and information concerning membership into CORSA and our club. So far this season James Ray has taken first place in every event he has entered. By the way, for those of you who missed the Christmas Banquet, James received the Most Valuable Member Award.

As most of you know we have a decal fund to raise money for our club decals. The amount needed is \$150.00 and we are at the \$30.00 point right now. Members may donate \$5.00 if they wish or contribute in some other way. Kathy Miller will have a Tupperware party at her house on Sunday, Feb. 9, for all the club women.

We'd like to take this opportunity to "welcome aboard" our new members; Bill Raybon, Harold Hartline, and Johnie Hill, Jr. They joined at our last meeting. This puts us close to the 40 member mark. Harold, a lawyer, is helping us set up the constitution.

MEETING HAS CHANGED. It will be on Friday, Feb. 14, 7:30pm, at the First National Southern Natural building. We felt that it would be nice to have a good meeting followed by some party-making at Kathy and Lee Miller's house. The meeting itself is very important. Convention plans must be discussed, elections will be held, and dues collected. Also, coffee will be served and we will even have a program by Dave Holder on the Corvair engine: The first of many such programs designed to help us understand our fine machines. We hope to have the largest crowd ever at this meeting.

At the Jan. meeting David Bibby was appointed committee chairman in charge of finding out the best people for office. The following list is of our current officers who will accept re-election as well as names of those people that members felt would also be good choices. Lee Miller, Butch Baldone, James Ray, Dave Holder, David Bibby, Louise Ray, Alyce Godfrey and Kathy Miller. The positions you will be voting on are: President, 1st VP, 2nd VP, secretary and treasurer. We are still in the pioneer stage and good leadership is needed.

Concerning the Mini Convention:

The most important thing this month and every month until May, will be the CONVENTION. You may not know this, but you are going to be part of one of the best conventions ever held. Things really look good. Reservations are coming in at about one a day which is more than we expected this early in the year. And phone calls have come in from Texas, N. C., New Jersey, Mass., West Virginia, Florida and Kentucky concerning the convention. One man in Texas who owns 65 Corvairs asked that we send 20 additional registration forms.

(Continued next page)

Blast from the Past! 40 Years of the Vulcan Corvair Enthusiasts (cont.)

Below is a list of the Chairmen involved with the various categories of the convention. These people will need the support and enthusiasm of all the members. We will be having periodical meetings to make sure all departments are moving along smoothly. You will notice that we have enclosed a revised membership list so that you can begin to form your committees. It would be really refreshing if at the meeting it was discovered that you had done your homework and have your committees all set up. EVERYONE should be on at least one committee and many will be asked to be on more than one. Don't wait to call. In case you haven't figured it up, on the night of the meeting there will only be 77 more days until "D" day. Man, this convention is going to be something else!

Publicity and Correspondence:	Lee Miller
Registration:	Alyce Godfrey
Banquets and parties:	Frank Ranelli
Beverages and Set-ups:	Butch Baldone
Decorations and signs:	Kathy Miller
Rally:	David Bibby
Concours:	James Ray
Race Day:	Don Godfrey
Manufacture's Display:	Dean Kock
Swap Meet:	Harold Hartline
Official Hosts:	All Members!



Vulcan Corvair Enthusiasts



Birmingham, Alabama
Corsa Chapter, 352

Phil Hartline, age 16, standing next to his dad's car, a red '66 Corsa coupe.

Phil recalls; "I believe at this point it was all original. For that matter, it still has the original engine in it, which has never been taken out of the car. We were on the track at Talladega, getting ready for the pre-race parade lap for the Winston 500. After the lap, we got to watch the race from the infield. That was at the Birmingham Mini-Convention, in 1975. Dad was gracious enough to let me drive, it was quite a thrill for a 16 year old to get to drive around that track."

CLASSIFIEDS

For Sale From Bill Turner Estate (Located in NC):

For more information, call Bill's daughter, Cathy Orders @ 423-245-7602 or 910-640-8973

1969 Blue Corvair, all original \$7,000.00



1962 Red Corvair Convertible \$1500

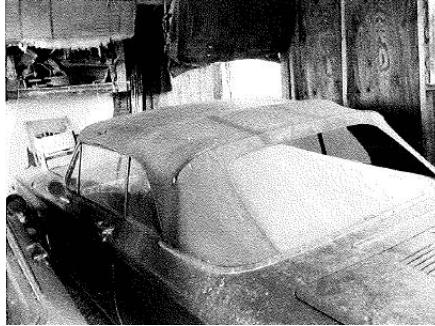

1961 Corvair truck with extra rebuild(?) \$1000

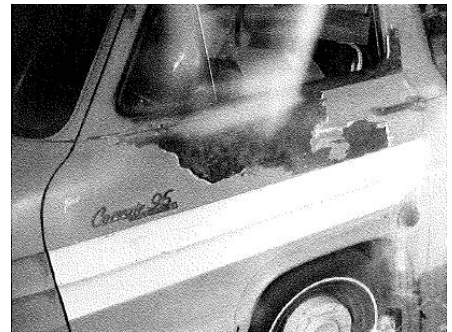

Not pictured, but also available:

1965 Corvair shell with A/C unit \$200.00

1991 black Infiniti, engine knocking, new tires, \$300.00; 1978 Silver Cadillac, \$7,000.00-\$5,000.00; 1987 Silver Ford Van, new tires & aluminum mag wheels, \$700.00-\$500.00; 1991 Black Infiniti, engine knocking, new tires, \$300.00; 2002 Lincoln, \$4,000.00

CLASSIFIEDS (cont.)



For Sale: 1963 Corvair Monza Convertible

Linda Towery has this car for sale. It's a gorgeous car with some recent restoration work. It also needs a little body repair work on the left rear quarter. Linda would also welcome anyone's help with how to sell the car, even if you aren't interested in making the purchase yourself.

Please contact Linda at 205-213-0055 or dnl towery@aol.com

Wanted: 1961 Rampside Tailgate

We've been working at restoring a Rampside we've had for quite a few years. So far we've replaced the carburetors, air cleaner system, and the brakes and brake linings. The body has been restored, also, with a new windshield etc. It's looking really good, but the tailgate could not be saved.

We plan to be at Helen with or without the Rampside. If anyone has a tailgate to spare, perhaps we could make a deal there.

Faye Heal

478 451-7118

Milledgeville, GA

For Sale: 1965 Corvair Corsa Street Legal Race Car

Is set-up to race, but is registered in GA and street driven. Features: two racing seats with 5 point harnesses Rollbar, Stock Suspension, 140+hp motor mostly stock: Mods: electric fuel pump, fuel pressure regulator, Fuel cell, Ignitor II (no points), FlameThrower (45K) coil, 14" Olds wheels and BF Goodrich AT Radials tires, Decals are removable, 4spd trans w/Quik shift Parts have been removed but nothing that can't be put back. Car looks good, runs great and fast. \$4500 Al Hilderbrant @ 770-974-3283

For Sale: 1961 Corvair Monza 700

Believe it's the original 85hp / PowerGlide, Hounds tooth (2tone) interior, New (\$800) Tires, Runs Good, \$3900 770-974-3283

Vulcan Corvair Enthusiasts, a chapter of the Corvair Society of America, is a non-profit club dedicated to the preservation and restoration of the Corvair automobile.

VCE dues of \$20/year pay for a family membership and 12 issues of the Oil Drop Newsletter.

President: Richard Stolzmann 205/467-6444 Vice President: Pete Wood 205/956-6832 Secretary: Russ Thuleen 205/678-7979 Newsletter Editor: Billy Cannon 256/839-1905 Treasurer: Joe Dougherty 205/995-0131

Hospitality: Harold Hartline Arrangements: Judi Cannon



THE OFFICIAL NEWSLETTER OF THE VULCAN CORVAIR ENTHUSIASTS Vol 35, No 3

March 2014



THE PRESIDENT’S COLUMN:

Ok, time for another Presidents message.
 Russ Thuleen, Billy Cannon, Ed & Carol Keller, Chris Brown, Molly Bacon, Clyde & Brenda Cork and I went to the Pensacola fun in the sun event. In spite of the rain early Friday morning we really had good weather Friday and Saturday during the day when all the activities occurred. The turn out was down with a few folks canceling because of the possibility of bad weather. We didn't have a club meeting as we decided with the low club turn out to delay it till the March regular meeting.
 Russ gave his famous rebuilding of the steering box tech session. Everyone seemed to be real interested as the price of a new steering box is around 5-6 hundred dollars. it is a lot cheaper to do it yourself with the deluxe rebuild kit that Clark's provides at \$101.00.
 I hope to see everyone at our meeting on the 21st of March.
 Reminder- Russell Noble should have our T shirts and polo shirts at the March meeting.

REFLECTIONS FROM THE SEAT OF AN OLD TRACTOR

"Meanness just doesn't happen over night."

Corvaire

Next Meeting:

Date: Friday, March 21, 2014
 Time: 7:00 PM
 Place: FULLNESS CHISTIAN FELLOWSHIP

In This Issue:

- Upcoming Events.....(2)
- WFCC Corvaire Lovers Holiday.....(3 & 4)
- Tech Tip (EM Wheels & Fuel Leaks).....(5)
- Classifieds.....(6 & 7)



Web Links 4 U!
 Jay Leno's 1966 Corvaire Yenke Stinger
[Jay Leno's Garage](#)

Upcoming Events!

March 7-9 Spring Warm-Up

Myrtle Beach SC. Central Carolina CORSA
Car show, hospitality, valve cover race, Bingo, poker/
scavenger hunt, and swap meet. Vendors free with
show registration.

Sea Mist Resort, 1200 S. Ocean Blvd.,
Myrtle Beach SC, 800/732-6478, mention 846171 for
special rates until February 10th.
Jerry Brown, 4049 Liberty Church Rd.,
Manning SC 29102, 803/225-0005

April 18-19 Springfest, Helen Ga.

Hosted by Corvair Atlanta, Heart of Georgia Cor-
vairs, Queen City Corvair Club.
Autocross and hospitality party on Friday. Saturday
concours, people's choice, valve cover races, and
more. Clark's Corvair Parts will be attending. Host
Helendorf River End, 706/878-2271, \$89 per night,
two nights minimum for riverside, \$69 per night for
standard; Best Western 800/435-3642, \$69 standard,
\$89 suites; Super 8, 800/535-1251, \$55. Make reser-
vations before March 15. Lillian Law,
lawjandl@aol.com, 229/883-4123, cell 229/291-0567.

May 10 Picnic, Guntersville, Al.

Hosted by Vulcan, Choo Choo, with invites to Cor-
vair Atlanta and Heart of Georgia Corvairs,
Details are still being firmed up but it will be an all
day affair at Guntersville State Park.

July 21-25, 2014 CORSA International Conven- tion, Tacoma, WA.

Hosted by 'Corvanatics'. Join us for "Corvair Expo"
where the LeMay Automobile Museum will be the
center of convention events as well as displays and
activities celebrating the Corvair. Host hotel is Hotel
Murano in Tacoma, 888/862-3255, mention
"Corvairs" or CORSA" for special \$109 room rate.



Doc Wasson's "Lilith".
An example of our unusual Alabama Weather this year.

VCE Monthly Meeting Minutes

It was decided by attending VCE members that the
February meeting at the Corvair Lovers Holiday in
Pensacola should not be held. All business was de-
ferred to the March meeting.

Russell Nobel reports that the 40th anniversary
shirts should be available for pick-up at the March
meeting.

Vulcan *Corvair* Enthusiasts



40th Anniversary 1974-2014



VCE President, Richard Stolzman's 180hp Corsa 'vert at
the Corvair Lovers Holiday.

Send Oil Drop submissions to:

GTOChief@gmail.com

Office: 256-839-1905

Cell: 256-404-5998

**NOTE: PLEASE SEND SUBMISSIONS NO
LATER THAN THE 25TH OF THE MONTH.**



West Florida Corvair Club (WFCC) Corvair Lovers Holiday



VCE cars showing at the peoples choice event on Saturday. Russ Thuleen's 'Shorty' 1962 Loadside, Billy Cannon's 'TBO' 1965 Corsa, Molly Bacon and Chris Brown's 1962 wagon. Richard's car is on page 2.

Corvair

WFCC Pensacola Beach, Fl.

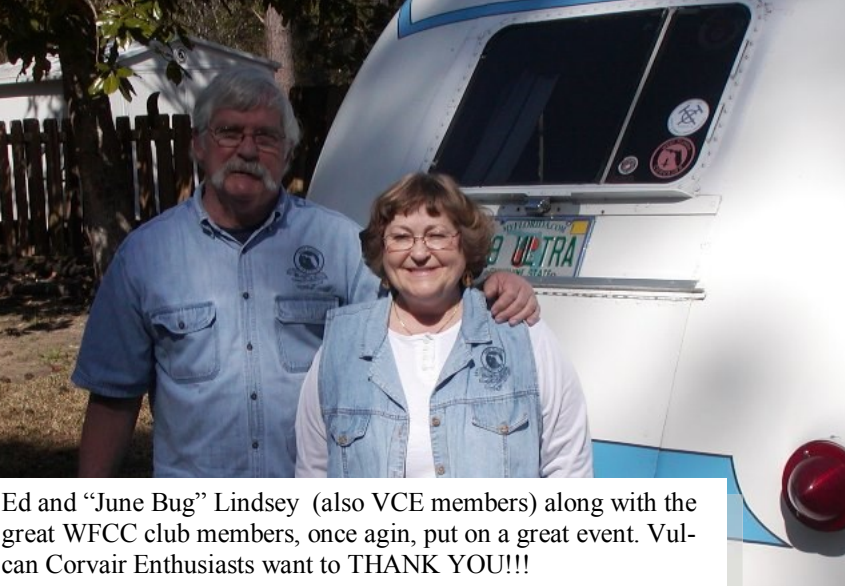
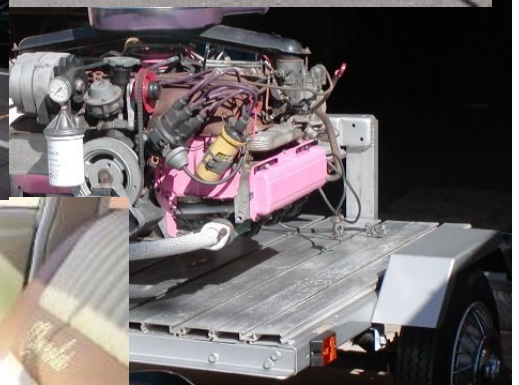

Ed and "June Bug" Lindsey (also VCE members) along with the great WFCC club members, once agin, put on a great event. Vulcan Corvair Enthusiasts want to THANK YOU!!!

Tech Tip
What Wheels Will Fit Your EM {4 on 4-1/2 (4 on 114.3mm)}

13 inch tires are getting harder to find! Here is a list of alternatives that will allow the use of larger tire sizes on your Early:

Acura

Legend '86-'90
CL 1996 - 2000
TL 2.5 1996 - 1998
Vigor 1992 - 1994

Buick

Special '61-'63

Chevrolet

Corvair all 4-bolt
Chevy II all 4-bolt
Sprint '85-'87
Nova '61-'70

Dodge Colt '79-'88

Dodge Colt (early)

Eagle

Summit 1990 - 1992
Summit Wagon 1993 - 1996

Ford

Mustang all '65-'68 4-bolt
Falcon, Maverick, Granada all 4-bolt

Honda

Accord 1990 - 1997
Accord 4cyl 1998 - 2002
Prelude 1992 - 1996

Hyundai

Elantra 1991 -
Excel 1988 - 1994
Scoupe 1990 - 1994
Sonata 1990 -
Tiburon 1997 - 2002

Infiniti G20 1990 - 2002

Mazda - 626, RX7 '83-'87 ????

Mercury Tracer 1986 - 1990

MGA, MGB, MGC

Mitsubishi

Expo LRV 1994 - 1994
Galant (4 lugs) 1983 - 1998
Lancer LS, OZ Rally 2002 -

Nissan/Datsun - most models to '89

240SX 1989 - 1994
240SX (4cyl) 1995 - 1998
Altima 1993 - 2000
Maxima 1985 - 1988
Sentra 2000 -
Stanza 1990 - 1992

Olds - F-85 '61-'63

Plymouth - Arrow, Sapporo '79-'88

SAAB 900 to '87

Suzuki

Foreza 2004 -
Verona 2004 -

Toyota - most exc. MR2 and P.U. to '89

Triumph TR 1 - 6

Volvo

S40 2001 - 2004
V40 2000 -



Tech Tip
Fixing Fuel Leaks

Parker, Copper 45-degree Flare Gaskets

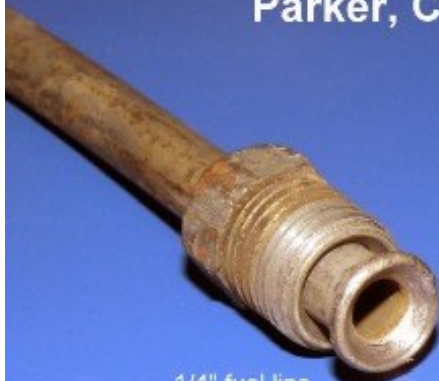

1/4" fuel line



Rochester H and HV
fuel inlet

These annealed copper flare gaskets can be used to help seal fuel leaks when old connections have been over-tightened too many times.



Parker 2GF-3 (for 3/16" lines)

These will work for 1/4" lines if you cannot locate 2GF-4 gaskets)



Parker 2GF-4 (for 1/4" fuel lines)
1/4" dia. fuel lines to Corvair carbs.



Parker 2GF-5 (for 5/16" fuel lines)

5/16" dia. feed line to Corvair fuel pump

azdave 2014

Image shows parts used to re-seal worn fuel line connections using soft copper sealing washers from Parker Hose store.

CLASSIFIEDS



For Sale: 1963 Corvair Monza Convertible

Linda Towery has this car for sale. It's a gorgeous car with some recent restoration work. It also needs a little body repair work on the left rear quarter. Linda would also welcome anyone's help with how to sell the car, even if you aren't interested in making the purchase yourself. Please contact Linda at 205-213-0055 or dnltowery@aol.com

CLASSIFIEDS (cont.)

For Sale: 1961 Corvair Monza 700

Believe it's the original 85hp / PowerGlide, Hounds tooth (2tone) interior, New (\$800) Tires, Runs Good. Reduced this month to \$3200 770-974-3283



For Sale: 1965 Corvair Corsa Street Legal Race Car

Is set-up to race, but is registered in GA and street driven. Features: two racing seats with 5 point harnesses, Rollbar, Stock Suspension, 140+hp motor mostly stock: Mods: electric fuel pump, fuel pressure regulator, Fuel cell, Igni-

tor II (no points), FlameThrower (45K) coil, 14" Olds wheels and BF Goodrich AT Radials tires, Decals are removable, 4spd trans w/Quik shift Parts have been removed but nothing that can't be put back. Car looks good, runs great and fast. Reduced this month to \$4100 Al Hilderbrant @ 770-974-3283

Club Member Ed Keller has two Earlies and one Late For Sale.

For Price and more details on these cars, contact Ed @ 205-447-5424 or e-mail him ekps119@bellsouth.net

Vulcan Corvair Enthusiasts, a chapter of the Corvair Society of America, is a non-profit club dedicated to the preservation and restoration of the Corvair automobile.

VCE dues of \$20/year pay for a family membership and 12 issues of the Oil Drop Newsletter.

President: Richard Stolzmann 205/467-6444 Vice President: Pete Wood 205/956-6832 Secretary: Russ Thuleen 205/678-7979 Newsletter Editor: Billy Cannon 256/839-1905 Treasurer: Joe Dougherty 205/995-0131

Hospitality: Harold Hartline Arrangements: Judi Cannon



THE OFFICIAL NEWSLETTER OF THE VULCAN CORVAIR ENTHUSIASTS Vol 35, No 4

April 2014

THE PRESIDENT'S COLUMN:

It's SPRINGFEST time again! The annual Helen, Ga. show is coming up on April 18th and 19th. Don't miss it.

Also don't forget our first annual Southeast Corvairs picnic on May 10th of this year. It will be at beautiful Lake Guntersville Alabama. I'm sure Billy Cannon our 'Oil Drop' editor will have details later in the newsletter.

We had a good turn out at our March meeting. As usual the food was terrific. Russel Noble distributed the VCE 40th Anniversary polo and T shirts that the club members had ordered. Judi Cannon drew the lucky 'gas prize' ticket and was able to put \$30.00 in her gas tank. This is twice in a row that the door prize has been \$30.00.

It was -7 degrees in Duluth Minnesota this morning. Glad I don't live there any more! .

REFLECTIONS FROM THE SEAT OF AN OLD TRACTOR

"Every path has a few puddles."



Next Meeting:

Date: Saturday, April 19, 2014

Time: To Be Determined

Place: SPRINGFEST 2014, Helen, Ga

In This Issue:

- Upcoming Events & Meeting Minutes.....(2)
- New Cruise-in Schedule.....(3)
- Blast from the Past (March 1975).....(5)
- Tech Tip (Alternator Upgrade).....(5 & 6)
- Southeast Corvairs Picnic Registration & Information Sheets.....(7-9)



Upcoming Events!

April 18-19 Springfest, Helen Ga.

Hosted by Corvair Atlanta, Heart of Georgia Corvairs, Queen City Corvair Club.

Autocross and hospitality party on Friday. Saturday concours, people's choice, valve cover races, and more. Clark's Corvair Parts will be attending. Host Helendorf River End, 706/878-2271, \$89 per night, two nights minimum for riverside, \$69 per night for standard; Best Western 800/435-3642, \$69 standard, \$89 suites; Super 8, 800/535-1251, \$55. Make reservations before March 15. Lillian Law, lawjandl@aol.com, 229/883-4123, cell 229/291-0567.

May 3, Shelby County College and Career Center's 4rd Annual Car, Truck, Motorcycle and Tractor Show.

Will be held at the school's campus in Columbiana. Silent auction, arts and crafts, business vendors, music, food and fun for the kids. Registration for VCE will be handled by Russ. You can also visit the website at <https://sites.google.com/site/schooloftechcarshow/home> for more details.

May 10 Southeast Corvairs Picnic, Guntersville, AL.

Hosted by Vulcan, and Choo Choo Corvairs, with invites to all clubs and Corvair owners throughout the Southeast, It will be an all day affair at Lake Guntersville State Park. See attached Registration and Supplemental on pages 7-9.

July 21-25, 2014 CORSA International Convention, Tacoma, WA.

Hosted by 'Corvanatics'. Join us for "Corvair Expo" where the LeMay Automobile Museum will be the center of convention events as well as displays and activities celebrating the Corvair. Host hotel is Hotel Murano in Tacoma, 888/862-3255, mention "Corvairs" or CORSA" for special \$109 room rate.



VCE Monthly Meeting Minutes

The March 21st meeting of the Vulcan Corvair Enthusiasts had an attendance of 24 members! A fantastic turnout after a week of such weird weather changes. Joe Doughty provided the Treasurer's Report - currently the club has a balance of \$642.40 in the bank.

Russell Noble brought in the long awaited club shirts and passed them out to the members. Some members ordered more than one since we had a choice of T- shirts or Polo shirts. They will be great advertisement for the club when people see members wearing them at car shows and cruise-ins this coming show season!

Billy discussed the May 10th picnic at Lake Guntersville with members being invited from the Tennessee Choo-Choo, Atlanta, and Heart of Georgia Corvair clubs. The event will take place at the newest pavilion at the state park and will be an all day get together. (details page 7) It was voted on that Billy will pay the park fee and the club will reimburse him. John and Billy will bring their BBQ grills and charcoal. More information will follow, so keep an eye on your email for details on supplies needed and a map to the park.

Springfest in Helen, Georgia is coming up in April. This year the event will be on the same weekend as Easter. There will be 10 club members attending. No meeting will be held at the church in April.

The club bylaws were discussed and John will send them to the officers to review before the meeting in May. Lifetime memberships were discussed briefly and the topic was tabled until the Bylaws were able to be reviewed, discussed and voted on.

It was mentioned that the Dixie Car Club will be having a car show at the Lazar Shrine on April 12th. The meeting was adjourned.

Send Oil Drop submissions to:

GTOChief@gmail.com

Office: 256-839-1905

Cell: 256-404-5998

NOTE: PLEASE SEND SUBMISSIONS NO LATER THAN THE 25TH OF THE MONTH.

**The Shelby County
College and Career Center's
Car, Truck, Motorcycle & Tractor
Show**

ANTIQUE & LATE MODEL VEHICLES

**Our 4th ANNUAL Car Show will be the
event of the year for the Entire FAMILY!
Show is FREE to the public.
There will be a Large Variety of Vehicles,
Oldies Music, Contest and Door Prizes
Many Unique Trophies**

Entrance Fees:

**Cars & Trucks \$15.00
Motorcycles & Tractors \$10.00**

Order T-Shirts by April, 11th



Alabama Cruise-in Locations

It's cruise in time again. Most locations report events March-October.

1st Saturday

*Hanceville—Dollar General parking lot US 31 6-9 PM
Gurley—Hardees Hwy 72 6-9 PM \$10 Registration
New Hope—Hardees US 431
Downtown Athens 4-9 through September
Alexander City—Arbys Hwy 280 6-9 PM
Birmingham—Hamburger Heaven Hwy 280
Ft. Payne—Twin City Auto Hwy 11
Jasper—JC Penny Mall*

2nd Saturday

*Boaz ; Ends at 8:00pm
Mall parking lot downtown AL
HWY 168
Springville; OneEighty Campus
(next to Burtons) 5770 U.S. Hwy
11
Clanton; 2nd Avenue and 6th
Street
McCalla; Colonial Promenade
Tannehill, Shopping Center, Exit 1
at I-459, 6-9pm,
Madison; (All Year) 2pm – 7, Jef-
ferson's Restaurant, Hwy 72 (near
intersection of Jeff Rd)*

3rd Saturday

*Scottsboro; Hardee's on Broad St
from 6pm until?
Gadsden; Sonic, AL Hwy 278
Sylacauga; Pickle Patch, Hwy 280
Centerville; (Mar – Nov) Advance
Auto Parts, 4-8
Hueytown; Winn Dixie Shopping
Center
Munford; Big Daddy's BBQ, Hwy
21.
Piedmont; Downtown*

4th Saturday

*Arab: (April - September)
6-9pm, Son's BBQ, north of Arab
on US Hwy 231. All welcome.
Fultondale; (April-Oct) Target
Parking lot Fultondale Colonial
Mall - 5-9 pm
Rainbow City; Charlie & Casey's
Pit & Grill 3225 Rainbow Dr.
Talladega; Chamber of Commerce
Parking Lot (Old Train Depot)*

5th Saturday

*Oneonta; (April - October)
Crossroads Cruisers Cruise-In
Downtown Oneonta from 5-8pm
April until October.*

Birthdays

**Doris Cleveland – April 8
Joshua Roth – April 9
Billy Cannon – April 21**

Blast from the Past! 40 Years of the Vulcan Corvair Enthusiasts



VULCAN CORVAIR ENTHUSIASTS

Birmingham, Alabama



March Newsletter

SITE OF THE CORVAIR SOCIETY OF AMERICA'S
MINI-CONVENTION MAY, 1975

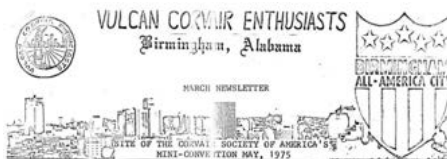

CONVENTION COUNTDOWN 49 DAYS TO GO

Developments in the convention.

Thanks to Butch Baldone, Pepsi-Cola will furnish us drinks for the convention free! Talladega is covered by another district and that man cannot furnish us drinks free, however, he will furnish them at cost. This is still a good deal. Dave Holder announces that European Auto's garage will be available for our use the entire weekend, so if we have any major repairs we've got a place to go. In conjunction with that, an agreement has been reached with Genuine Auto Parts whereby we can have access to their parts for the whole weekend. One important aspect has not been completed yet. In October we asked our members to go to their favorite parts store or whatever and ask if they would donate a door prize to be given at the convention in the store's name. So far not one member has let anyone know who they have contacted. So far we have received reservations from 11 states including two crazy guys in a '62 Monza from San Francisco!! But the real surge hasn't hit us yet. We've received phone calls from 13 other states many of which were in connection with "group participation". One such club in Pa. is getting a school bus and trucking it on down in that! Our club is starting to gel and organize itself for this event and this is great!

Now a word in closing from our ole' Prez. Himself (which is a job when you stop to think who writes these crazy newsletters):

For about four months I have been busting my "rearendus" to make sure that our convention is second only to one which has not ever been put on. I was recently asked to be National Public Relations Director for CORSA but turned it down because I felt an obligation to this fine club of ours and the superb event which we will be putting on in May. Now, all I ask is that you come through with all the support and enthusiasm you can find. It would make me (and you I'm sure) so very proud if Vulcan Corvair Enthusiasts were known as a leader among Corvair clubs in the United States. Also, at this time I would like to express a very sincere "Super Thanks" to all of you for getting together and setting up what Dave Newell, 19744 CORSA President said will be "the best event ever held for the Corvair Society of America!!! (And you know what? I agree!)

Signed by Lee Miller

Excerpts from the March 1975 Newsletter

How about new officers?

Well, we got 'um!

President:	Lee Miller
1st Vice President:	James Ray
2nd Vice President:	David Bibby
Secretary:	Alyce Godfrey
Treasurer:	Kathy Miller

These selections were made based on who could devote their time to the club. They will support the club as long as you support them and the club.

Car tab holders have arrived. For those of you who didn't order any, be sure and look at the Corvairs at the meeting.

Constitution ready for typing. Thanks to some over-the-weekend devoted time by Harold Hartline, our constitution and other important documents are ready for typing and ratification. Then, after a few more legal steps we'll receive our official charter from the State.

Vulcan Corvair Enthusiasts will soon be an official chartered member of CORSA. Under their new "Chapter Plan" we will receive many things to help make our club great, and in return we will help make CORSA great. That won't be hard....



Tech Tip

Late Model Alternator Upgrade by John Cleveland

There is an excellent article in the Corvair Technical Guide, Vol. 1 by Bob Helt describing in detail how to do this. I used it as a reference using a remanufactured internally regulated alternator. I also added the front bearing replacement in the reused front drive housing of my 37 amp alternator since it was making a lot of noise on cold mornings. You'll see in the picture below that it wasn't going to last much longer.



Here's the parts you'll need:

- The old alternator
- A new alternator, AC Delco 10-S1. When the kid at the parts store gives you a blank stare and asks you what kind of car, tell him a 1975 Chevy Nova with a 350 4 barrel. This will be a 67 amp alternator.
- An alternator cable extension which has the correct plug-in for the new alternator.
- A new bearing for the front drive housing of your old alternator. While you've got it off you may as well replace it. You probably don't know how old that alternator is and it's just a few bucks. The Timken bearing number is 203F.
- A piece of steel strap 1" wide, 1/8" thick and 14-16" long.

Mechanical

Start by disconnecting the positive battery terminal and removing the old alter-



nator. Take the pulley and fan off the old alternator. The '65 shop manual describes how to do this, or you can look at the picture at right. Insert an allen wrench in the end of the shaft and loosen the nut with a box end wrench. I had to use a long pipe nipple on the allen wrench as a 'cheater' to get the nut to break loose.

Remove the bolts holding the front housing.



Separate the front housing from the alternator body. Pay attention to the order of removal, nut, pulley, fan and spacer. There is also a spacer behind the bearing. They might have to be reused to get the old front housing to fit correctly on the new alternator.

Remove the backing plate holding the bearing.



The picture above might be kind of small, but the bearings were so worn they were oval instead of round. Note what the back of the bearing looks like so the new one goes in the same way. From the front of the housing insert a



socket that will just fit though the center hole and use a hammer to tap out the old bearing.



Clean up the housing and prep it for the new bearing. A light coat of grease around the wall where the bearing will go in will help installation.



I used a 2" square X 4" long piece of oak against the new bearing and tapped on that with a hammer. Once started it went right in. Make sure you get it started straight. A socket of the same diameter as the outside of the bearing would also work. Don't beat on it too hard. Follow the same procedure you used with the old alternator and take the pulley, fan and front housing off the new one. Again note the order, nut, pulley, fan, spacer.



(Continued on page 6)

Tech Tip (cont.) Alternator Upgrade



Put the old front housing on the new alternator.

Pay attention to the relationship between the housing mounting holes (at bottom) and the wiring plug-in on the back. When looking at the alternator from the pulley end the wiring terminals should be on the right. Install the fan and pulley.

Rotate the alternator by hand and feel the rotation. This is where you may have to try the different spacers to get the smoothest feel. There will be some in and out play until you tighten the nut on the end of the shaft. Also one of the nuts might fit better than the other. I found using the new nut provided threads all the way through. The old nut was thicker. When it all looks and feels good torque the pulley nut per the Shop Manual. Mount the alternator in the car with the two bottom bolts. Don't put the top brace on.

Electrical

Now it's time to wire the new cable extension to the existing wiring. I cut the old plug-in off about an inch after the wire came out of the harness. This left enough on the old plug that it could be reused. Since my old alternator was still good I'm keeping it as a spare, along with the old plug and voltage regulator. In the picture terminal 1 is the bottom and terminal 2 is at the top.

Terminal 1 will connect to the blue wire going to the regulator. Terminal 2 will connect to the white or white/black ('65) wire going to the regulator. I soldered

the connections and used heat shrink tube for the connection.

THIS IS NOT A PLACE FOR CRIMP CONNECTIONS!

The connection to the battery goes on the stud similar to the old alternator. Here's a picture of the connection that went to the voltage regulator.



Since the new alternator is internally regulated, you can't use the old regulator. I used spade connector jumpers between the outside terminals and a jumper between the inside terminals. This was later sealed with liquid tape and tied down to the wiring harness below the old voltage regulator. I also removed the voltage regulator. A permanent connection could be made by cutting the wires from the bottom of the connector and soldering them together.



The last step is to make a new top bracket with the steel strap. The new alternator is about 1/2" to 3/4" taller than the old one and there was no way I could get my old top brace to fit. Yours might work but for me it was off to the home center to get some 1" wide steel. The 1/8" thickness is thin enough I could shape the bends in my vice with a hammer. It didn't turn out half bad.



The whole job, including the trip to the home center and making the bracket, took about 3 hours. Cost was around \$75.

Tools were a set of wrenches, a large allen wrench, torque wrench, which you could probably do without, ratchet and sockets, hammer, hack saw, soldering iron, and crimp tool.

Consumables were flat black spray paint (for the new alternator and bracket), a couple squirts of PB Blaster, a little grease to help the bearing get started, solder, heat shrink tubing and some male crimp connectors. There was also a few beers in there,optional, of course.



Southeast Corvairs Picnic 2014 Registration Form
Hosted by Vulcan Corvair Enthusiasts (VCE) and Choo Choo Corvair
May 10, 2014 at Lake Guntersville State Park, Alabama

Name: _____ Spouse: _____

Address: _____ Phone: _____

City: _____ State: _____ Zip: _____

Club Affiliation: _____ Email: _____

Any young children in your group: _____

Corvair Display

Vehicle description: Year: _____ Color: _____ Model: _____
Check all that apply: Early Closed Early Open Late Closed Late Open
 Forward Control 4-Door class (includes Lakewoods) Specialty-modified

There is no registration deadline but we ask that you complete the registration and get it back to VCE as soon as you can for event planning purposes.

Event details:

Lake Guntersville operating hours are from 7:00 AM until sundown. You are welcome to plan your arrival for any time prior to Noon on Saturday. We will have lunch ready around 1:00 PM. Activities are planned throughout the day with a Corvair and their owners photo opportunity scheduled for 3:00 PM. The park rangers will have the paved area adjacent to the pavilion roped off from general parking. We will have signs and directions to the display area prominently displayed for the public. Although the 'Buckeye Pavilion' is covered and has picnic tables inside and out, we suggest that you bring your own lawn chairs and encouraged to bring your club banners.

VCE and Choo Choo will provide the cooking grills, charcoal, condiments, and ice. Designated club members will do the cooking.

We ask that each attendee bring your own picnic type food.

Please indicate below what you will be bringing so that the cooks will have some idea when to start the charcoals.

There will be a \$1.00/ticket raffle drawing for 'Gas Money'

Vulcan Corvairs has the tradition of conducting a raffle at each monthly meeting. Buy as many tickets as you want. Winner takes all to put gas in the tank of their Corvair. We will hold a similar drawing at the picnic.

Liability Clause: Entrants and participants by execution of this form release and hold harmless Vulcan Corvair Enthusiasts. (Members and Officers), Choo Choo Corvairs (Members and Officers) and anyone else connected with the management or presentation of this event, from any and all known damages, injuries, losses, judgments, and/or claims from any causes whatsoever that may be suffered by any entrant or participant to his or her personal property (including family members or friends).

Signature of Registered Guest

Signature of Registered Guest

Date

For convenience, completed registrations may be emailed to: Gtochief@gmail.com

Mailing Address:

Southeast Corvair Picnic, c/o
Vulcan Corvair Enthusiasts, CORSA Ch. 352
147 Crossbrook Dr. Chelsea, AL 35403

Southeast Corvairs Picnic 2014 Supplemental Information

Directions:

The park is only six miles northeast of Guntersville on Highway 227. Guntersville may be entered via highways 431, 79 and 69. Should you choose to use an internet mapping service and it tells you to take Martling as your route into the park, we encourage you to stay on the main roads of Highways 431 and 227 instead. The roads through Martling can be confusing and cause you to become lost if you are not familiar with this community.

From outside Alabama:

Atlanta - Take Interstate 20 towards Alabama. Take the Oxford, Alabama exit at Highway 431. Follow Hwy. 31 North through An-niston, Gadsden, & Albertville, into Guntersville. Follow Alabama Highway 227 South into Guntersville State Park.

Atlanta - Take GA. Highway 20 towards Rome. Follow Hwy. 20 into Alabama where it becomes Alabama Highway 9. Follow Hwy. 9 to the intersection of Hwy. 9/AL. Hwy. 35. Turn left onto Hwy. 35 and follow Hwy. 35 North to Rainsville. Turn left in Rainsville onto Alabama Highway 75 towards Fyffe. Turn right onto County Rd. 400 and follow until it merges with Alabama Hwy. 227. Stay straight on 227 and follow into Guntersville State Park.

Chattanooga - Enter Alabama from South Pittsburg and follow Highway 72 West towards Scottsboro. Take Alabama Hwy. 79 into Guntersville. Merge left onto Hwy. 431 South to a left on Hwy. 227 South into Guntersville State Park.

Chattanooga - Enter Alabama via Interstate 59. Follow I-59 to the second Fort Payne exit #218. Turn right onto Alabama Hwy. 35 and follow Hwy. 35 North to Rainsville. Turn left onto Alabama Highway 75 towards Fyffe. Turn right onto County Rd. 400 and follow until it merges with Alabama Hwy. 227. Stay straight on 227 and follow into Guntersville State Park.

Tupelo - Take U.S. Hwy. 78 into Alabama and merge onto U.S. Hwy. 278 towards Cullman. Take Hwy. 69 just outside of Cullman into Guntersville. Take Hwy. 227 into Guntersville State Park.

Meridian - Follow I-59 into Alabama towards Tuscaloosa. Stay on I-59 North to Birmingham and into Gadsden. Take the Hwy. 431 exit and follow Hwy. 431 North to Guntersville. Turn onto Hwy. 227 South into Guntersville State Park.

State Park Pet Policy:

Dogs are permitted in designated day use areas and dog friendly facilities if on a leash and attended to at all times. Other than the designated ‘dog-friendly’ units, dogs are not allowed in any other building, at the beach, or by the swimming pool. Pet owners are required to clean up after their pets and are responsible for their actions.

Lodging:

Although the picnic is a one day affair, you are encouraged to come and spend part of the Mother’s day weekend with family and friends.

If you will be staying at the Lake Guntersville State Park Lodge please call the reservationist at 256-505-6621 to make reservations. After business hours, or on weekends, you may call the front desk at 256-571-5440. To receive the Corvair rate extended to our group please mention that you are with Vulcan Corvair – market code 4425.

Points of Contact:

VCE

Choo Choo

Billy B. Cannon Jr. VCE Oil Drop Editor Office Phone: 256-839-1905 Mobile: 256-404-5998	Mark Guider Head Engineer- Choo Choo Corvairs Office Phone: - Trains don’t have phones Mobile: 423-667-9288
Richard Stolzman. VCE Club President Home Phone: 205-467-6444 Mobile: 205-329-0394	Ed McClintock Chugging Along Editor Home Phone: 423-478-2335 Mobile: 423-309-8018
Russ Thuleen. VCE Club Secretary Home Phone: 205-678-7979 Mobile: 205-451-9626	Melvin Hopkins Choo Choo Banker Mobile: 706-217-5123



Above: Buckeye Pavilion with inside and outside picnic tables
 Right: View of Lake Guntersville from the Pavilion , Paved area for Corvair Display



Corvair

Vulcan Corvair Enthusiasts, a chapter of the Corvair Society of America, is a non-profit club dedicated to the preservation and restoration of the Corvair automobile.
 VCE dues of \$20/year pay for a family membership and 12 issues of the Oil Drop Newsletter.
 President: Richard Stolzmann 205/467-6444 Vice President: Pete Wood 205/956-6832 Secretary: Russ Thuleen 205/678-7979 Newsletter Editor: Billy Cannon 256/839-1905 Treasurer: Joe Dougherty 205/995-0131
 Hospitality: Harold Hartline Arrangements: Judi Cannon



THE OFFICIAL NEWSLETTER OF THE VULCAN CORVAIR ENTHUSIASTS Vol 35, No 5



1960



1961



1962



1963



1964

**EARLY CORVAIR
SPOTTERS GUIDE**

May 2014

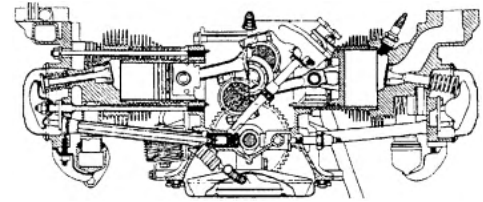

Next Meeting:

Date: Friday, May 16, 2014

Time: 7:00 PM

Place: Fullnes Christian Fellowship Center, 2575 Columbiana Rd, Vestavia Hills, Al 35216

THE PRESIDENT'S COLUMN:

It's almost May! We are having our first combined club picnic May 10th at Lake Guntersville State Park. Make sure to attend, it will be a fun day for everyone. We will be having our normal third Friday meeting on the 16th of May at 7 Pm.

Make sure to wear our 40th year Vulcan Corvair polo and t shirts. We need to advertise our Club. Hope to see everyone at Guntersville.

Sorry to say I missed Helen this year, but Billy will have info on it elsewhere in this newsletter.

**REFLECTIONS FROM THE SEAT
OF AN OLD TRACTOR**

“Your fences need to be horse-high, pig-tight and bull-strong.”

In This Issue:

Upcoming Events.....	(2)
Cruise-in Schedule.....	(3)
Corvair Grand Sport (1/25 Scale).....	(4)
VCE at SPRINGFEST.....	(6)
Willow Run.....	(7)
Tech Tip.....	(9)
SPRINGFEST 2014.....	(10)
Southeast Corvairs Picnic.....	(11)

VCE Monthly Meeting Minutes

No formal meeting was held in April due to the attendance of members at SPRINGFEST.

Upcoming Events!

May 3, Shelby County College and Career Center's 4rd Annual Car, Truck, Motorcycle and Tractor Show.

Will be held at the school's campus in Columbiana. Silent auction, arts and crafts, business vendors, music, food and fun for the kids. Registration for VCE will be handled by Russ. You can also visit the website at <https://sites.google.com/site/schooloftechcarshow/home> for more details.

May 10 Southeast Corvairs Picnic, Guntersville, AL.

Hosted by Vulcan, and Choo Choo Corvairs, with invites to all clubs and Corvair owners throughout the Southeast,

It will be an all day affair at Lake Guntersville State Park. See attached Registration and Supplemental on pages 11-13.

July 21-25, 2014 CORSA International Convention, Tacoma, WA.

Hosted by 'Corvanatics'. Join us for "Corvair Expo" where the LeMay Automobile Museum will be the center of convention events as well as displays and activities celebrating the Corvair. Host hotel is Hotel Murano in Tacoma, 888/862-3255, mention "Corvairs" or CORSA" for special \$109 room rate.

October 3-4, 2014 Vairs at the Fair, Warner Robins, GA.

Sponsored by Heart of Georgia Corvairs Friday Night hospitality, Saturday we lead the parade into the Georgia National Fair and display our Corvairs. Saturday night dinner will be catfish and shrimp. Host Motel, Days Inn & Suites, 215 Margie Drive, Warner Robins, Ga. 478 953 6866.

Ask for Corvair Club rates of \$59.00. Info. contact Lillian Law 229 883 4123 cell 229 291 0567 or lawjandl@aol.com.



SPRINGFEST 2014 PEOPLE'S CHOICE RESULTS

Early Closed

1st Grady McDaniel 64 Red Spyder

Early Open

1st Pattie Jenkins 64 White Monza
2nd Ed McClintock 63 Red
3rd Tom White 64 Red Monza
4th Al Ruch 64 Maroon Monza

Late Closed

1st Ben Carey 65 Black Corsa
2nd Travis Jenkins 69 Green Monza
3rd Ed Kelly 68 Ivory Monza
3rd Raymond Pease 65 Yellow Monza
4th Cecil Triplett 67 Red Monza

Late Open

1st Dennis Findley 65 Blue Monza
2nd Kim Murrell 68 Gold
3rd Rob Fields 69 Blue Monza
4th Jerry Wells 65 Corsa

4 Door

1st Dante Bernardini 64 Red Monza
2nd Keith Burkingstock 64 Red Monza
3rd John Downer 65 Grey Monza Sport Sedan
4th Cameron Gribble 65 White Monza

Station Wagon

1st Ed McClintock 61 Blue Lakewood
2nd Keith Henline 61 Teal/white Lakewood

Forward Control

1st Dee Charest 64 Green Rampside
2nd Dean Gemberling 62 Orange Rampside
3rd Donnie Bird 63 White Panel Truck
4th Glenn Kelly 61 Yellowish Rampside

Specialty

1st James Cheek 63 Silver Sprint
2nd Dick Charest 65 Red Corsa Coupe
3rd Eddie Meadows 60 Red Dixie T
4th Dick Berger 68 Blue

**2014 Great Plains
Corvair
Round Up**

A Corvair Society of America sanctioned Mini-convention

Branson, MO September 30-October 4

Send Oil Drop submissions to:

GTOChief@gmail.com

Office: 256-839-1905

Cell: 256-404-5998

NOTE: PLEASE SEND SUBMISSIONS NO LATER THAN THE 25TH OF THE MONTH.

**The Shelby County
College and Career Center's
Car, Truck, Motorcycle & Tractor
Show**

ANTIQUE & LATE MODEL VEHICLES

**Our 4th ANNUAL Car Show will be the event of the year for the Entire FAMILY!
Show is FREE to the public.
There will be a Large Variety of Vehicles,
Oldies Music, Contest and Door Prizes
Many Unique Trophies**

Entrance Fees:
Cars & Trucks \$15.00
Motorcycles & Tractors \$10.00

Alabama Cruise-in Locations

It's cruise in time again. Most locations report events March-October.

1st Saturday

Hanceville—Dollar General parking lot US 31 6-9 PM

Gurley—Hardees Hwy 72 6-9 PM \$10 Registration

New Hope—Hardees US 431

Downtown Athens 4-9 through September

Alexander City—Arbys Hwy 280 6-9 PM

Birmingham—Hamburger Heaven Hwy 280

Ft. Payne—Twin City Auto Hwy 11

Jasper—JC Penny Mall

2nd Saturday

Boaz ; Ends at 8:00pm

Mall parking lot downtown AL HWY 168

*Springville; OneEighty Campus (next to Burtons)
5770 U.S. Hwy 11*

Clanton; 2nd Avenue and 6th Street

McCalla; Colonial Promenade Tannehill, Shopping Center, Exit 1 at I-459, 6-9pm,

Madison; (All Year) 2pm – 7, Jefferson's Restaurant, Hwy 72 (near intersection of Jeff Rd)

3rd Saturday

Scottsboro; Hardee's on Broad St from 6pm until?

*Gadsden; Sonic, AL Hwy 278
Sylacauga; Pickle Patch, Hwy 280
Centerville; (Mar – Nov) Advance
Auto Parts, 4-8
Hueytown; Winn Dixie Shopping
Center
Munford; Big Daddy's BBQ, Hwy
21.*

Piedmont; Downtown

4th Saturday

Arab: (April - September)

*6-9pm, Son's BBQ, north of Arab
on US Hwy 231. All welcome.*

*Fultondale; (April-Oct) Target
Parking lot Fultondale Colonial
Mall - 5-9 pm*

*Rainbow City; Charlie & Casey's
Pit & Grill 3225 Rainbow Dr.*

*Talladega; Chamber of Commerce
Parking Lot (Old Train Depot)*

5th Saturday

Oneonta; (April - October)

Crossroads Cruisers Cruise-In

*Downtown Oneonta from 5-8pm
April until October.*



Russell Nobel's Corsa 'vert at the Krispy Kreme Cruise-In

Birthdays

Sherri Daniels— May 22

Floyd Snider— May 25

Molly Bacon – May 29

Jerry Smith – May 30

Corvair Grand Sport

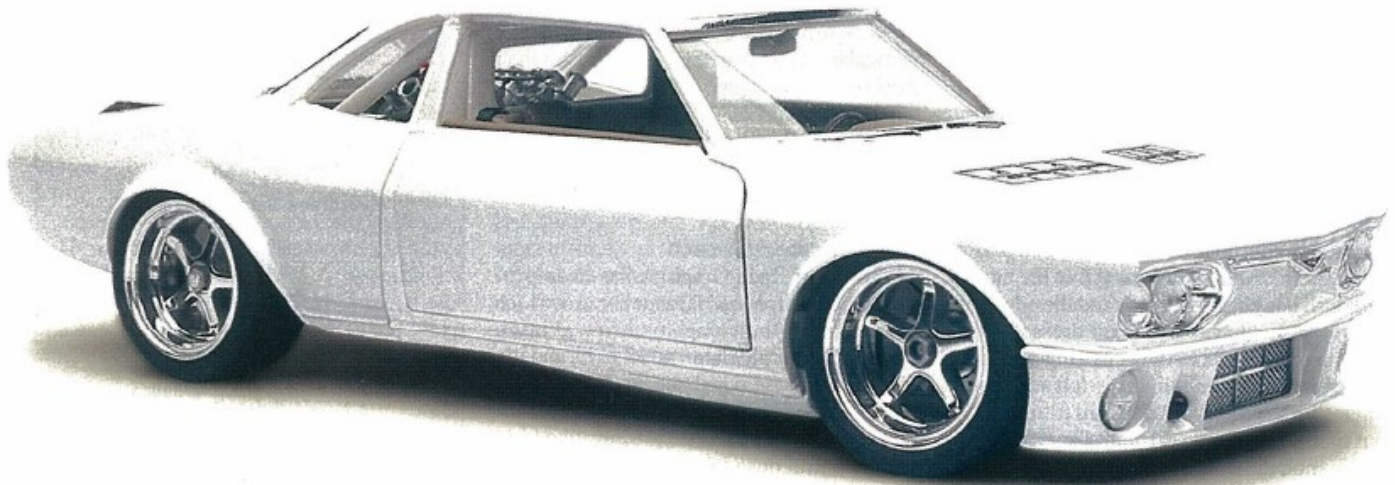

Bill Cunningham's V-8 powered Corvair is unbelievable at any speed

by MATTHEW USHER photos by PATRICK MULLIGAN

This is a reprint of the article originally published in the Mar 2000 issue of Scale Auto Enthusiast—ed.

BILL CUNNINGHAM'S love of Chevrolet's Corvair goes back a longtime—his first car was a white 1965 coupe, powered by a 95-horse-power six-cylinder engine. Years later, the car would serve as the inspiration for Bill's unbelievable V-8 powered Corvair Grand Sport model. Based on AMT/Ertl's 1/25 scale Prestige kit, the model has the V-8 engine from Accurate Miniatures' Corvette Grand Sport mounted amidships, where it's

mated to the transaxle and rear suspension from Tamiya's Porsche 962. "If I were to build a 1:1 custom Corvair, I would probably make it just like this model," Bill says. "I strived to make sure that the design was practical and realistic. A car such as this could actually be built and driven." "In the late '70s, there was a little-known aftermarket conversion kit offered by Crown Manufacturing that allowed the midships installation of a

Chevy V-8 in the Corvair," Bill explains. "I used that concept of reversing the transaxle and mounting the engine where the rear seat should be. "The car's overall look is a carefully designed combination of 1970s and '90s technology, subtly capturing the flavor of both eras. Bill wanted the model's viewers to see hints of the Corvette Grand Sports or Can-Am Chaparrals in the model. Bill spent more than a year reworking and detailing every aspect of the model to suit his design philosophy. The doors are hinged and fit with magnetic catches. Likewise, Bill opened the engine compartment and installed self-erecting hood supports. All of the interior body panels were made from styrene sheet and hand fit to accommodate the engine and modified bodywork. Externally, the standard wheel arches were radiused

(Continued on page 5)

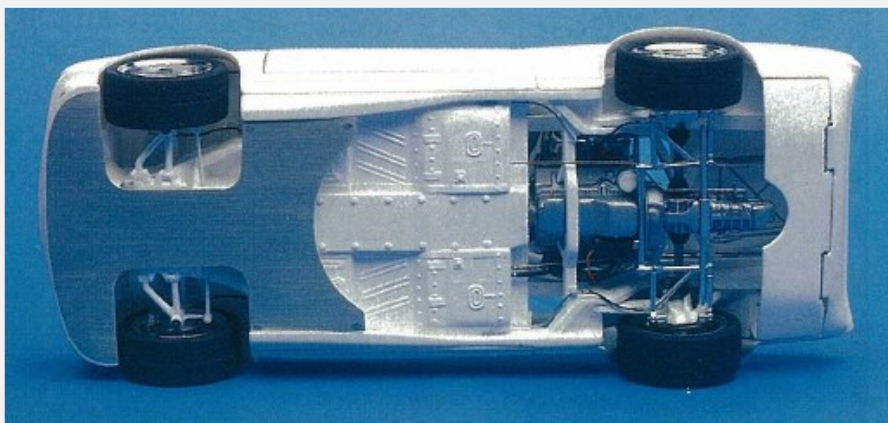

The complexity of installing the Grand Sport V-8 is particularly evident in the underside view. Bill made the partial belly pan from nickel-silver sheet, the same material from which he photoetched many of the model's detail parts.

(Continued from page 4)

and flared to handle the model's custom-made two-piece turned-aluminum wheels and Aoshima tires. Although there are a few aftermarket parts in the model, Bill produced many of the machined-aluminum and photo-etched-metal detail parts himself. The Grand Sport 377 cid V-8, already a well-detailed assembly right out of the box, benefits from complete wiring and fuel-system plumbing, plus custom photoetched carburetor flanges and throttle linkages. Upfront, complete brake plumbing leads to machined-aluminum and photoetched-metal disc brake assemblies. Bill sprayed the body with water-based Createx Pearl White acrylic paint mixed 1:1 with Future floor shine. He applied the color with a Testors Aztek airbrush and polished it to a high shine with Micro-Mesh polishing cloths. Testors Model Master acrylics were then used to paint the rest of the model. Bill's imaginative engineering and clean building style make the finished model a standout on contest tables. The hybrid Chevrolet took top honors in the

Custom category at the 1999 International Plastic Modelers' Society Nationals in Orlando, Fl., and also claimed a second-place trophy in the Custom class at the 17th Greater Salt Lake International Model Car Championship. Several elements came together to create this exceptional model: Bill's love of the Corvair, understanding of automotive design and engineering, and refined building skills have resulted in a model that is unbelievable at any speed ... even sitting still.

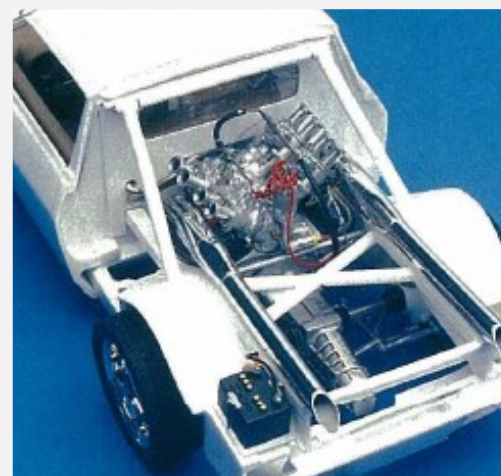

Accurate Minature's Corvette V-8 is hiding under all of the machined and photoetched metal detail parts Bill installed. Note the Porsche 962 transaxel and rear suspension, visible through the tube frame Bill fabricated.

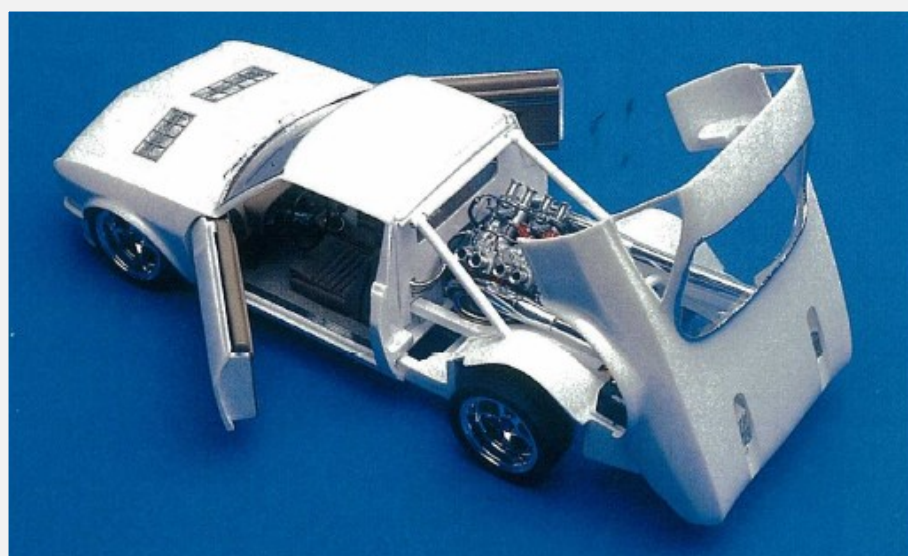

Bill mixed water-based Createx acrylic paint with Future floor shine to give the model its beautiful pearl-white finish. He applied the mixture with a Testors Aztek airbrush, then polished it with Micro-Mesh polishing cloths.

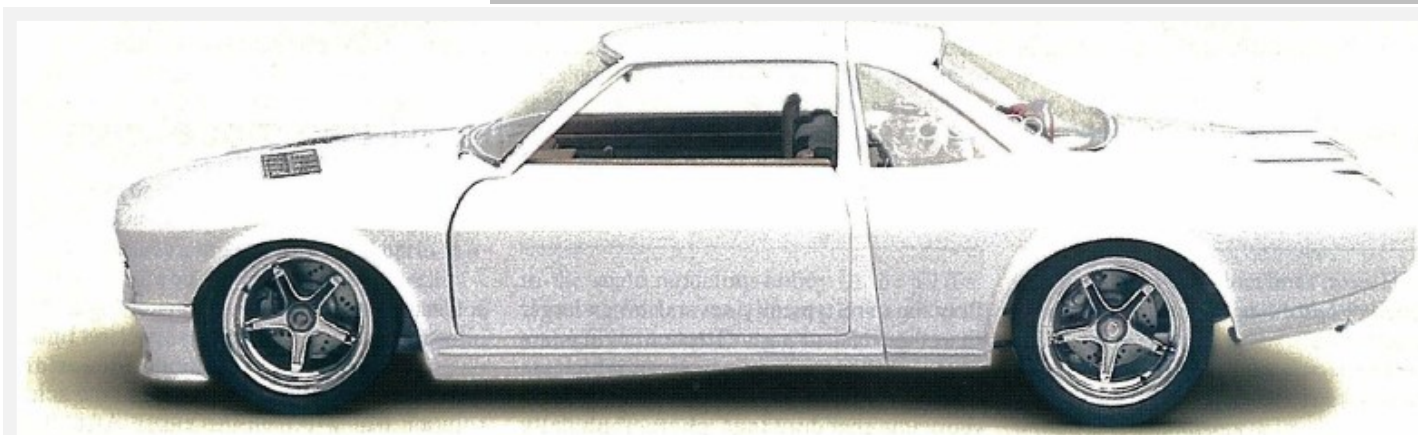

MODEL SPECIFICATIONS

BUILDER: Bill Cunningham **MODEL:** 1967 Chevrolet Corvair **SCALE:** 1/25 **TIME TO BUILD:** 12 months

SPRINGFEST 2014



Al & Joan Birk's 1963 Red Spyder Convertible won a Silver award in the Concourse with a score of 92.12



Judi Cannon's 1967 Royal Plum Monza Convertible suffered a dead battery all weekend but contributed to the 'rainbow of colors' in the Late Open class.



Photo's courtesy of David Clamp. THANK YOU!



Russ Thuleen's Red White and Blue "Shorty" was well received by the crowd. We had to wipe off those nasty SPRINGFEST raindrops in the morning but it turned into a nice day for the peoples choice show.

Willow Run assembly plant demolition proceeding (From 'Hemmings')



segregated that and are demolishing the rest,” Callen said.

Yankee Air Museum officials launched a campaign last year to raise \$8 million to buy about 155,000 square feet of the plant, a portion that includes the end of the assembly line and the bay doors through which every completed B-24 bomber rolled out of the plant during World War II. Former GM chairman Bob Lutz stepped in to help the campaign, as did retired astronaut Jack Lousma, and RACER Trust worked with museum officials to push the deadline back multiple times last year. The current deadline of May 1 is the last that RACER has offered, but Norton said he is confident the museum will raise the final \$1.2 million by then.

While the effort to save a portion of the Willow Run assembly plant has come down to its final week, demolition crews have already torn down about half of the former Kaiser-Frazer and GM structure outside of Ypsilanti, Michigan, to make way for an autonomous vehicle research facility.

“Every single day big chunks are coming down,” said Dennis Norton, director of the Michigan Aerospace Foundation and original founder of the Yankee Air Museum, which has so far raised \$6.8 million of the \$8 million necessary to purchase a fraction of the plant. “Now that the weather has warmed up, the

demolition crews are going to move rapidly.”

Bulldozers arrived on the site to begin tearing down the 5-million-square-foot facility last fall after the RACER development trust – which took possession of the plant after GM shut down operations there in late 2010 – reached a deal last September with Walbridge Development to build a shared research and development center and test track for connected vehicles. According to Bill Callen, speaking for RACER Trust, demolition slowed down during the long and hard Michigan winter, but is now about 50 percent complete. “The demolition contractors know that the museum has an interest in that portion of the plant, so they’ve



First photo of the new General Motors Corvair. This photo was taken in a fenced-off parking lot near the new Chevrolet plant at Willow Run, Mich. It's the first public view of the four-door Corvair sedans which GM will introduce in October as its compact car entry. August 23, 1959

“I’m about 95 percent sure we’ll sign the purchase agreement by May 1,” Norton said. “That \$8 million will take care of building two new walls to close up the section and to put in utilities like heat and a fire suppression system. It’ll be an almost new building when we’re done with it.”

Built on land owned by Henry Ford to crank out B-24 Liberator bombers in 1941, the Albert Kahn-designed plant became the largest single industrial building under one roof. Once it ramped up to full production in late 1943, the so-called “Grand Canyon of the mechanized world” would produce a bomber per hour, along with a number of wood-bodied gliders.

(Continued on page 8)



Artist's rendering of the Yankee Air Museum in the Willow Run Bomber plant.

(Continued from page 7)

After the war, Ford declined its option to buy the massive plant from the federal government, so the government – through the Reconstruction Finance Corporation and the War Assets Administration – ended up leasing, and eventually selling, Willow Run to the newly formed Kaiser-Frazer. Kaiser-Frazer converted Willow Run to automotive production and built cars there from June 1946 to July 1953 before selling the plant to General Motors for \$26 million. GM used the plant to build Hydra-Matic transmissions and other powertrain components until December 2010, when it shed the property as part of its bankruptcy.

RACER, which obtained the 332-acre plant not long after, attempted to sell portions of the property to other industrial companies, but pointed to the massive plant as an impediment to finding new tenants and thus decided to tear it down last year. Not long after, RACER signed a contract with Walbridge to sell the property after demolition is complete. Callen said that the demolition was slated to take a full year, but Norton said he believes that demolition will be complete by about mid-July.



Artist's conception of the small Chevrolet based on trade reports. This drawing shows air intake for flat six-cylinder engine behind rear window. Model is expected to have more room than an average imported economy car. December 18, 1958



Here are three of the new Chevrolet passenger cars for 1961, which will make their bow to the public Friday. On the left is the Greenbrier sports wagon, one of the newcomers in the Corvair line. In the center is the new Impala convertible. At right, another new Corvair model is the Lakewood station wagon with rear engine. October 5, 1960

FOR MORE INFO CALL 256.236.0996 OR STOP BY OUR OFFICE AT 1018 NOBLE ST

PRESENTED BY SPIRIT OF ANNISTON

Merchant Sales Live Music

4th FRIDAYS on Noble St

5:00-8PM

PLAY DOWNTOWN

Bounce House Art Exhibits Car Show Bar and Restaurant Specials

APRIL - SEPTEMBER 2014
4.25 / 5.23 / 6.27 / 7.25 / 8.22 / 9.26

Special thanks to our Sponsors
AL POWER * ALAQASCO * ANNISTON EMS * EASTMAN * RMC

WWW.SPIRITOFFANNISTON.ORG

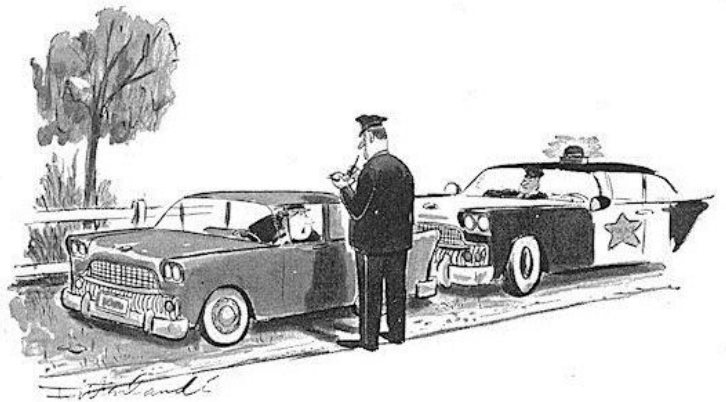

"I didn't think you fellows would pick on a small American car."



Oil Drop Editor, Billy Cannon, placed 3rd in the SPRINGFEST 2014 Autocross Late Model competition with a best time of 33.97 sec.

Tech Tip *'65 Suspension Components*

VCE President, Richard Stolzman is in the process of restoring his current project. The front and rear suspension components have been completely disassembled, sandblasted and painted. Good work Richard!



SPRINGFEST 2014 Report *submitted by Lillian Law:*

Registrations:—————160

People:—————we fed 256 some just came on Saturday and did not eat just looked and bought parts from Cal Clark and others.

States Represented:—————13 ** 32 club were represented

Number fed on Friday Night——256

Number fed on Saturday Night—225

I had more than 80 people on list for Thursday night and more than that came. We overflowed the big room.

Long Distance:—————Teresa Miller---Des Moines,Iowa---900 miles

Shopping Spree—————Wendy Price & Rhonda Gail Gleaton

Early Registration:—————Reggie McCrory cancelled and was refunded money

50/50 Friday:—————Jake Ratledge \$238.00

50/50 Saturday —————Mary Graham: \$130.00

Set Of Tires—————Billy Price

Hard Luck:—————James Grilles Powell Tenn. Drove from Knoxville, Tenn. with a flat tire on the front. Said he didn't even know it.

Been To All 30 Shows:—————Jack Allison

Valve Cover Races

Adults

1. Gary Greenwood, Jr.
2. Dan Gianotti
3. Nicole Cary
4. Mikey Burkinbine

Kids

1. Trey Greenwood
2. Tommy Greenwood
3. Cameron Gribble

Please express my sincere thanks to every person that participated in Springfest. I get far too much credit, it takes every one of us to make it a success. I am looking forward to many more Springfest. If anyone has suggestions to make it better please let us know. We do not always use all suggestions but still like to get them.

Note: We sold 94 shirts and needed more.

FULTONDALE Cruise-in



Russell Noble's Corsair convertible amidst a 'sea' of Mustangs during the Fourth Saturday cruise in held at the Target parking area of the Colonial Mall. Come on out and support Russell stem the tide of ponies. 5-9 PM



Southeast Corvairs Picnic 2014 Registration Form
Hosted by Vulcan Corvair Enthusiasts (VCE) and Choo Choo Corvair
May 10, 2014 at Lake Guntersville State Park, Alabama

Name: _____ Spouse: _____

Address: _____ Phone: _____

City: _____ State: _____ Zip: _____

Club Affiliation: _____ Email: _____

Any young children in your group: _____

Corvair Display

Vehicle description: Year: _____ Color: _____ Model: _____

Check all that apply: Early Closed Early Open Late Closed Late Open
 Forward Control 4-Door class (includes Lakewoods) Specialty-modified

There is no registration deadline but we ask that you complete the registration and get it back to VCE as soon as you can for event planning purposes.

Event details:

Lake Guntersville operating hours are from 7:00 AM until sundown. You are welcome to plan your arrival for any time prior to Noon on Saturday. We will have lunch ready around 1:00 PM. Activities are planned throughout the day with a Corvair and their owners photo opportunity scheduled for 3:00 PM. The park rangers will have the paved area adjacent to the pavilion roped off from general parking. We will have signs and directions to the display area prominently displayed for the public.

Although the 'Buckeye Pavilion' is covered and has picnic tables inside and out, we suggest that you bring your own lawn chairs and encouraged to bring your club banners.

VCE and Choo Choo will provide the cooking grills, charcoal, condiments, and ice. Designated club members will do the cooking.

We ask that each attendee bring your own picnic type food.

Please indicate below what you will be bringing so that the cooks will have some idea when to start the charcoals.

There will be a \$1.00/ticket raffle drawing for 'Gas Money'

Vulcan Corvairs has the tradition of conducting a raffle at each monthly meeting. Buy as many tickets as you want. Winner takes all to put gas in the tank of their Corvair. We will hold a similar drawing at the picnic.

Liability Clause: Entrants and participants by execution of this form release and hold harmless Vulcan Corvair Enthusiasts. (Members and Officers), Choo Choo Corvairs (Members and Officers) and anyone else connected with the management or presentation of this event, from any and all known damages, injuries, losses, judgments, and/or claims from any causes whatsoever that may be suffered by any entrant or participant to his or her personal property (including family members or friends).

Signature of Registered Guest

Signature of Registered Guest

Date

For convenience, completed registrations may be emailed to: Gtochief@gmail.com

Mailing Address:

Southeast Corvair Picnic, c/o
Vulcan Corvair Enthusiasts, CORSA Ch. 352
147 Crossbrook Dr. Chelsea, AL 35403

Southeast Corvairs Picnic 2014 Supplemental Information

Directions:

The park is only six miles northeast of Guntersville on Highway 227. Guntersville may be entered via highways 431, 79 and 69. Should you choose to use an internet mapping service and it tells you to take Martling as your route into the park, we encourage you to stay on the main roads of Highways 431 and 227 instead. The roads through Martling can be confusing and cause you to become lost if you are not familiar with this community.

From outside Alabama:

Atlanta - Take Interstate 20 towards Alabama. Take the Oxford, Alabama exit at Highway 431. Follow Hwy. 31 North through An-niston, Gadsden, & Albertville, into Guntersville. Follow Alabama Highway 227 South into Guntersville State Park.

Atlanta - Take GA. Highway 20 towards Rome. Follow Hwy. 20 into Alabama where it becomes Alabama Highway 9. Follow Hwy. 9 to the intersection of Hwy. 9/AL. Hwy. 35. Turn left onto Hwy. 35 and follow Hwy. 35 North to Rainsville. Turn left in Rainsville onto Alabama Highway 75 towards Fyffe. Turn right onto County Rd. 400 and follow until it merges with Alabama Hwy. 227. Stay straight on 227 and follow into Guntersville State Park.

Chattanooga - Enter Alabama from South Pittsburg and follow Highway 72 West towards Scottsboro. Take Alabama Hwy. 79 into Guntersville. Merge left onto Hwy. 431 South to a left on Hwy. 227 South into Guntersville State Park.

Chattanooga - Enter Alabama via Interstate 59. Follow I-59 to the second Fort Payne exit #218. Turn right onto Alabama Hwy. 35 and follow Hwy. 35 North to Rainsville. Turn left onto Alabama Highway 75 towards Fyffe. Turn right onto County Rd. 400 and follow until it merges with Alabama Hwy. 227. Stay straight on 227 and follow into Guntersville State Park.

Tupelo - Take U.S. Hwy. 78 into Alabama and merge onto U.S. Hwy. 278 towards Cullman. Take Hwy. 69 just outside of Cullman into Guntersville. Take Hwy. 227 into Guntersville State Park.

Meridian - Follow I-59 into Alabama towards Tuscaloosa. Stay on I-59 North to Birmingham and into Gadsden. Take the Hwy. 431 exit and follow Hwy. 431 North to Guntersville. Turn onto Hwy. 227 South into Guntersville State Park.

State Park Pet Policy:

Dogs are permitted in designated day use areas and dog friendly facilities if on a leash and attended to at all times. Other than the designated ‘dog-friendly’ units, dogs are not allowed in any other building, at the beach, or by the swimming pool. Pet owners are required to clean up after their pets and are responsible for their actions.

Lodging:

Although the picnic is a one day affair, you are encouraged to come and spend part of the Mother’s day weekend with family and friends.

If you will be staying at the Lake Guntersville State Park Lodge please call the reservationist at 256-505-6621 to make reservations. After business hours, or on weekends, you may call the front desk at 256-571-5440. To receive the Corvair rate extended to our group please mention that you are with Vulcan Corvair – market code 4425.

Points of Contact:

VCE

Choo Choo

Billy B. Cannon Jr. VCE Oil Drop Editor Office Phone: 256-839-1905 Mobile: 256-404-5998	Mark Guider Head Engineer- Choo Choo Corvairs Office Phone: - Trains don’t have phones Mobile: 423-667-9288
Richard Stolzman. VCE Club President Home Phone: 205-467-6444 Mobile: 205-329-0394	Ed McClintock Chugging Along Editor Home Phone: 423-478-2335 Mobile: 423-309-8018
Russ Thuleen. VCE Club Secretary Home Phone: 205-678-7979 Mobile: 205-451-9626	Melvin Hopkins Choo Choo Banker Mobile: 706-217-5123



Above: Buckeye Pavilion with inside and outside picnic tables
 Right: View of Lake Guntersville from the Pavilion , Paved area for Corvair Display



Vulcan Corvair Enthusiasts, a chapter of the Corvair Society of America, is a non-profit club dedicated to the preservation and restoration of the Corvair automobile.
 VCE dues of \$20/year pay for a family membership and 12 issues of the Oil Drop Newsletter.
 President: Richard Stolzmann 205/467-6444 Vice President: Pete Wood 205/956-6832 Secretary: Russ Thuleen 205/678-7979 Newsletter Editor: Billy Cannon 256/839-1905 Treasurer: Joe Doughty 205/995-0131
 Hospitality: Harold Hartline Arrangements: Judi Cannon



THE OFFICIAL NEWSLETTER OF THE VULCAN CORVAIR ENTHUSIASTS Vol 35, No 6

Vulcan Corvaair Enthusiasts

Birmingham, Alabama

Corsa Chapter. 352

June 2014

THE PRESIDENT’S COLUMN:

Well another month has gone by. If you missed the 1st annual Lake Guntersville picnic, you missed a good one. Even in spite of threatening rain which never materialized, we had 9 Corvaair vehicles, 29 adults and 5 children attend the picnic. Billy Cannon and Steve Daniels grilled hamburgers and hot dogs. With the other food that was brought we had more than enough and plenty left over. Pictures of folks that attended are included in this issue of the Oil Drop newsletter.

NEWS FLASH: As you know, at every VCE gathering, we have started to offer the opportunity to put money in a pot and for every dollar you will get a gas money ticket. I'm pleased to announce that Carol Keller got the winning ticket at the picnic and received a total payout of \$60.00 (Lucky Lady).

REFLECTIONS FROM THE SEAT OF AN OLD TRACTOR

“It don't take a very big person to carry a grudge .”

VCE Monthly Meeting Minutes

With 16 members in attendance, Joe reported a balance of \$496 in the treasury.

1. Officers meeting delayed until next month.
2. Picnic discussed, talk of next year’s plans.
3. There were 10 cars present at the SOT Car

show. And one of the attendees expressed interest in joining VCE.

4. Several members worked on Clyde’s fuel pump. John went home and got a replacement.
5. Richard had perpetual motion machine that he explained. (see pg.4)

Next Meeting:

Date: Friday, 20 June, 2014

Time: 7:00 PM

Place: Fullnes Christian Fellowship Center, 2575 Columbiana Rd, Vestavia Hills, Al 35216

In This Issue:

Upcoming Events.....	(2)
Happy VCE Anniversary.....	(3)
Perpetual Motion.....	(4)
UV #328.....	(5)
School of Technology.....	(6)
Tech Tip.....	(7)
Fultondale Cruise-in.....	(8)
Southeast Corvaairs Picnic.....	(10)



CORSA is now on [Facebook](#)

Upcoming Events!

July 21-25, 2014 CORSA International Convention, Tacoma, WA.

Hosted by 'Corvanatics'. Join us for "Corvair Expo" where the LeMay Automobile Museum will be the center of convention events as well as displays and activities celebrating the Corvair. Host hotel is Hotel Murano in Tacoma, 888/862-3255, mention "Corvairs" or CORSA" for special \$109 room rate.

October 3-4, 2014 Vairs at the Fair, Warner Robins, GA.

Sponsored by Heart of Georgia Corvairs
Friday Night hospitality, Saturday we lead the parade into the Georgia National Fair and display our Corvairs. Saturday night dinner will be catfish and shrimp. Host Motel, Days Inn & Suites, 215 Margie Drive, Warner Robins, Ga. 478 953 6866.

Ask for Corvair Club rates of \$59.00.
Info. contact Lillian Law 229 883 4123 cell 229 291 0567 or lawjandl@aol.com.

Send Oil Drop submissions to:

GTOChief@gmail.com

Office: 256-839-1905

Cell: 256-404-5998

NOTE: PLEASE SEND SUBMISSIONS NO LATER THAN THE 25TH OF THE MONTH.



Found on Facebook! Chris Rothe's '64 Spyder finally finished?
Your editor can't wait to see it in person.

2014 Great Plains
Corvair
Round Up

A Corvair Society of America sanctioned Mini-convention

A stylized illustration of a blue Corvair convertible driving towards the left. The driver is wearing a cowboy hat and a vest, and is holding a large orange object. The car is shown with motion lines and clouds of dust or smoke behind it.

Branson, MO

September 30-
October 4



VULCAN CORVAIR ENTHUSIASTS - HAPPY 40TH ANNIVERSARY!!

John Cleveland

I never could find that elusive 'first issue' of the VCE newsletter, which I believe would have been June 1974. However, I went five years ahead to the fifth anniversary and have reprinted the President's article from a very short June 1979 issue.

In June 1974 the Club had a new address at 800 Belwood Circle, Fairfield, AL. and the treasurer's report showed \$312.79 in the bank. The club president was Jim Black.

JUNE 1979 NEWSLETTER

Hello again. There are several items I need to report on this month, so here goes!

ITEM #1: As I announced at our last meeting, Don Ferguson has resigned as ACTIVITIES VICE PRESIDENT. Son has a work conflict that has been keeping him from attending the meetings and activities. He is not sure at this time how long this will last, but is anxious to be able to attend the meetings and activities again. We appreciate the good job he did and hate to lose him, but do understand about work coming first. As it states in our Constitution, I made the announcement of his resignation at our last meeting, so at the June meeting we will elect someone to fill Don's unexpired term. Everyone be thinking about who they would like to have in this office.

ITEM #2: The GARAGE SALE which was held at our home on Saturday, June 2 was a lot of fun and also made the Club some needed revenue. I would like to thank Hatton and Mary Sanders, Jim & Bobbie & Robert Floyd, Don & Alyce Godfrey, Harold & Louise Hartline, Ben McCracken, Sharon Black, and my little Mother, Virginia Black, for their donations to the sale. Also a big thanks to Louise Hartline, Don & Alyce Godfrey & Sharon Black for their help during the sale. Also, to Christy Black who did a fine job as cashier. So far we have made \$140.90 on the sale. We do have some things left over and plan on having another sale later on. We welcome more donations and help for this other sale.

ITEM #3: Everyone who is interested in improved performance, gas mileage, starting and overall operation, be sure to attend the June meeting. Mr. Ben McCracken will be giving us his secrets on how to achieve these things. Ben has done a lot of research and work on this subject, so lets all attend the meeting and support his efforts.

ITEM #4: Mr. Ray Coffey is now offering upholstery services, carpets, hatracks, and other items. For those of us at the last meeting who saw the seat that he had covered, the carpets that he had sewn and the vinyl covered hatrack, there is no doubt as to the superior quality of his work. So anyone who is considering having any of this work done, would do well to contact Ray. Lets give him our support in this new venture.

ITEM #5: We now have our new calling cards with the Club's emblem used on them in place of the CORSA emblem we used before. These will be available at the June meeting.

ITEM #6: Don't forget our drive & picnic to Tannehill State Park on Sunday, June 17. This is Father's Day, so some may be unable to attend. All of you that can, please attend. We well leave the Westgate Mall in Bessemer at 10:30 sharp Sunday morning. We have tables reserved. Don't forget your chow.

ITEM #7: As of this writing, Alyce Godfrey is in Longview General Hospital in Graysville but is expected to be home Tuesday. We all wish her a very speedy recovery.

ITEM #8: With Frank Ranelli's able help and connections, we are negotiating for shirts with the Club emblem silk screened on. These are 1) golf type, pull-over shirts with buttons part way down the front, and 2) bowling type shirts with buttons all the way down the front.

I will have samples available at the meeting for you to inspect and to pick the style that you would like. The cost looks like it will be approximately \$6.50/\$7.00 per shirt, so if these shirts strike your fancy, have you money ready at the meeting so I can turn the order in. These will be ready for the trip to Atlanta in June.

Jim Black

President, 1978-79

The Perpetual Motion Machine

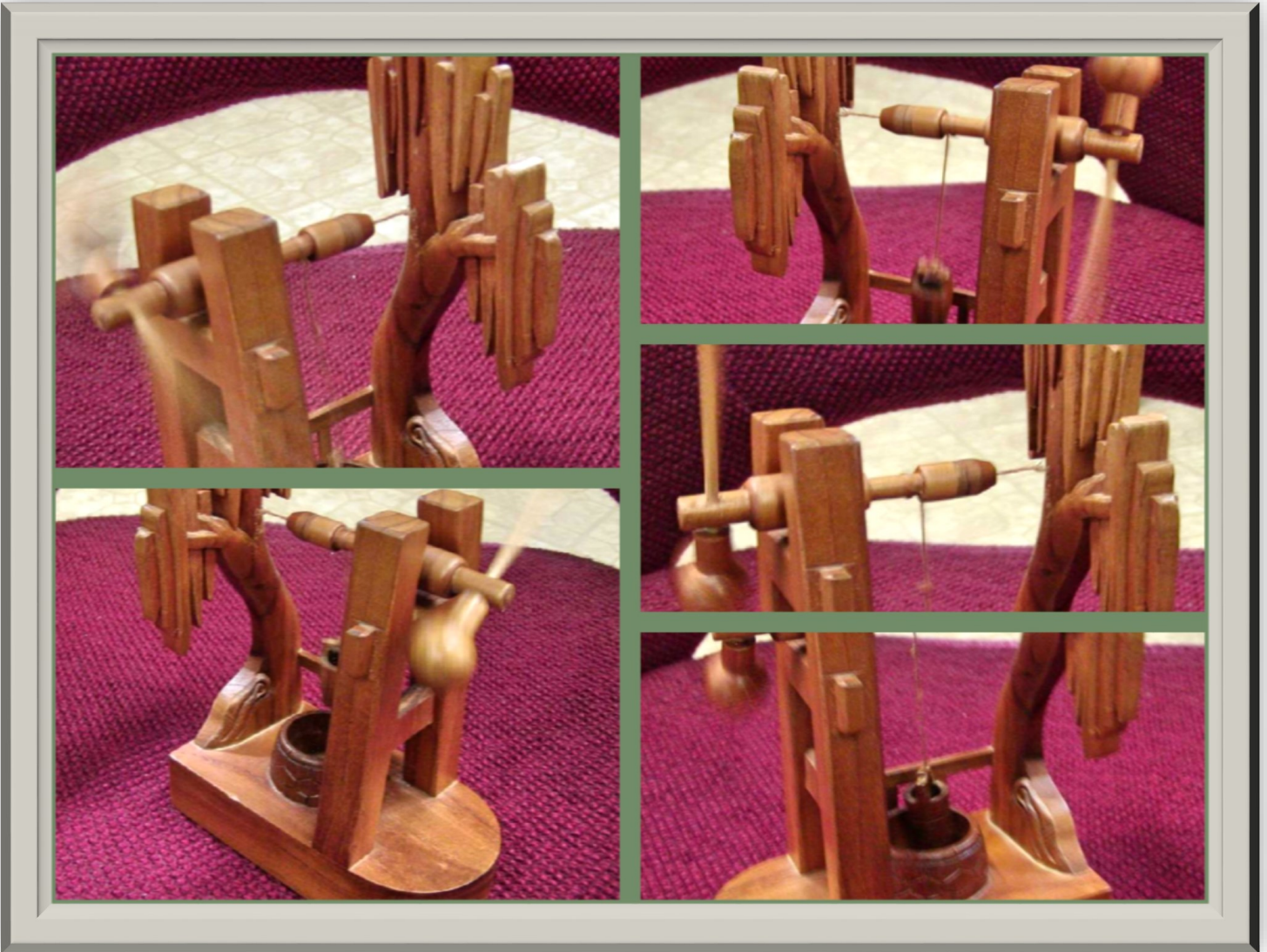

Richard bought his little machine in Helen about 20 years ago and thought it was really neat. As you can see it uses a magnetic bearing, no friction, it winds up a string which is then attached to a hook. The only place the shaft is attached to. A string winds up and pulls a bucket out of the well, then it reverses direction and lowers the bucket back in the well. It will run for weeks if you do it right.



ULTRA VAN #328

Chris and Molly have added another unique Corvair powered vehicle to the VCE stable.



Following is a reprint from the article Molly wrote for the Corvanatics Newsletter:

The drive home was uneventful. We happen to only live about 60 miles from the seller. Nice easy trip straight south down a rural two lane Georgia highway. The only thing I noticed was there were no brake lights. When we got home Chris tested and determined it was the switch. He gave it to me to stop by O'Reilly's when I was in town doing my weekly grocery shopping. The lady at the counter was sharp. When I told her it was an Ultra Van, described it, and showed her a picture, she immediately looked up a 68 Chevy C-10 truck and there was the picture matching the switch I had from UV #328. That solved that.

I had not ridden in it yet and asked if we could take an Ultra Van cruise. We knew they were "maypop" tires, but 'Hey!' we just drove 60 miles home. What's another couple miles? Chris came back a way he'd never been and missed the turn and then I started to hear a "whopping" noise. We were on the Georgia highway that runs the crest of Pine Mountain (a favorite of all the bikers). Fortunately, right there, was one of those many scenic turnouts. Pulled in and there it was, the right rear, flat as a pancake. Since we have a travel trailer, we have RV roadside assistance. So, even though we were about five miles from home, we gave them a call. But being in rural Georgia, on Mother's Day, the only assistance they could get was over in Alabama and it would be a couple hours. Chris started to walk home. I had settled in writing emails on my iPhone, on the sofa with the windows open and a nice breeze coming in. Which was good, as it was 4PM and a hot and humid Georgia 92 degrees. After about 6 or 7 minutes I heard a car pull in the turnout and then a man and a lady talking. "Wonder if it has a bathroom, oh, it must be from the 50s." I stood up and looked out the win-

(Continued on page 8)

Shelby County School of Technology Show 2014



George and his friends, Russ and Scooby, showed the kids what a real 'Mystery Machine' van is all about.....



....and then Russ taught them all about Corvair trucks.



As has been the case for the last few years, VCE has always supported the school with the largest club participation. Thanks to William and Sharon for joining us with their beautiful Black Turbo charged Corsa.



I was totally surprised when my little buggy won the 'Most Unique of the Show' award.

Tech Tip *'65 Suspension Components*

VCE President, Richard Stolzman continues the process of restoring the front and rear suspension components of his 4 door!

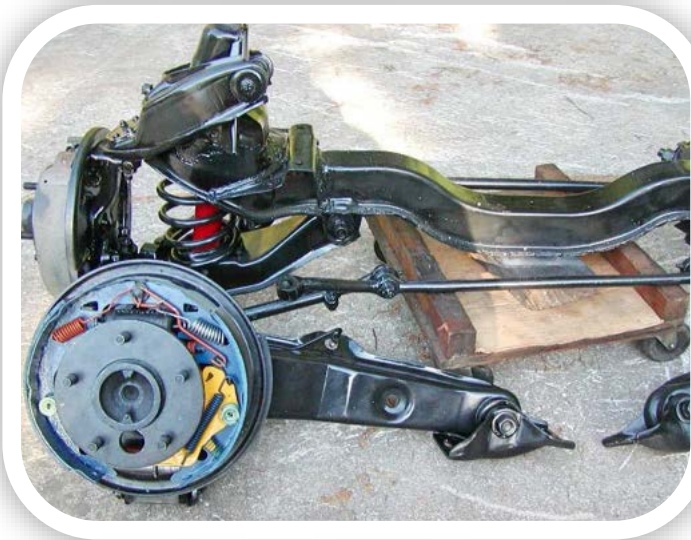

On Another Note:

As some of you know, two or three times now my 65 turbo convertible has been having some ignition issues, it will just cut out and back fire for no good reason. When I left the last meeting, of course it was dark and I noticed my generator light was glowing dimly. I thought oh no not another problem! As I went down the road it got brighter and brighter, then the engine would cut out or backfire, my original problem was back.. After the back fire or cut out the generator light was again dim and it would get brighter and brighter and the cut out or back fire would occur. after about the 5th or sixth time, I started thinking, that the only variable was the ignition switch. I already had pulled the wiring harness in the engine compartment and under the dash and checked the connectors. So I turned the ignition switch further clock wise toward the crank position. Low and behold the generator light went out and I had no further problems on the way home. I'm glad to say it occurred in the dark and I could see the generator light glowing faintly. I'll take ignition switch apart and see if I can't get some good pictures of the failing contacts. (Richard)

FULTONDALE Cruise-in



An excellent turnout of five VCE Corvairs at this month's cruise-in. Thanks to Russell for the pictures of Clyde's '64 Spyder, Chris and Josh's new presentations of early and late, Bryan's tribute to Hoyt and Russel's own faithful, 'neon lit' Corsa. The stable of running and driving Vulcans is growing. Great job folks!

ULTRA VAN #328

(Continued from page 5)

dow and they said, oh you heard us. I told them it was a 68 and it did have a bathroom. They were a couple about our age (60-ish) and said they were RVers and wanted to know if we had help. I told them we just live at the edge of the state park less than five miles and Chris was walking. The man said, oh no, I have to go get him and give him a ride. I told him Chris probably should almost be home, but he still left in his Mercedes convertible to find Chris. Chris was about a mile from home by then. The guy picked Chris up. When they got to our development, Chris said, "You really don't want to take me down our road as it's pretty nasty." It is. It's what is left of a shabby 40 year old paving job washed away by all those rains that run off the mountain and erode away everything in its path. The man said, "Oh, this is my daily driver, it doesn't matter." Had to be an \$80K+ MB. So, what's his good car??? Anyway, RVers are great folks even if they don't own vintage rigs. Needless to say, Chris got back a bit quicker. He'd taken one of the wheels from the rampside and voila, a spare tire, ready to go. Easy trip back home.

Now for some new tires. We have hoped to put the aluminum mag wheels that came on the rampside on UV #328, but after getting them all on and then pulling it into its parking spot, it was discovered they rub on the upper A-arms. Back to the drawing board.



Southeast Corvairs 1st Annual Picnic Lake Guntersville State Park, Alabama

Many, Many thanks to the folks from Choo Choo Corvair that helped us 'Vulcaners' with, despite the odds, our 1st picnic and get together combining two Corvair clubs. Sandy Chesney and her staff welcomed us with open arms and made it clear that this would be a 'feather in the cap' for the Park to endorse this event as an annual affair. For those that were not able to attend, I will let the pictures speak for themselves, because the few of us that braved the threat of weather, just had a BLAST!

SEE YOU NEXT YEAR





Above: View of the Corvairs from the outside deck of the Beautiful Guntersville Lodge. As you can see...we had room for plenty more.



Corvair



Vulcan Corvair Enthusiasts, a chapter of the Corvair Society of America, is a non-profit club dedicated to the preservation and restoration of the Corvair automobile.
 VCE dues of \$20/year pay for a family membership and 12 issues of the Oil Drop Newsletter.
 President: Richard Stolzmann 205/467-6444 Vice President: Pete Wood 205/956-6832 Secretary: Russ Thuleen 205/678-7979 Newsletter Editor: Billy Cannon 256/839-1905 Treasurer: Joe Doughy 205/995-0131
 Hospitality: Harold Hartline Arrangements: Judi Cannon



THE OFFICIAL NEWSLETTER OF THE VULCAN CORVAIR ENTHUSIASTS Vol 35, No 7

THE PRESIDENT’S COLUMN:

June has been a busy month for me. I was able to attend the June Vulcan Corvaire meeting in spite of having to leave for vacation early the next morning.

I'm sorry to say we didn't have a gas money drawing. Billy and Judi Cannon were out of town and I guess we didn't have any tickets.

Our family vacation on the lovely island of Hilton head was just great. We swam in the Atlantic ocean and during tide changes, especially when it was coming in the waves were just great. We stayed in a house one block back from the beach. We were in a gated community so we rode our bikes we had rented every where. The golf course offered us miles of concrete riding paths. Of course we partook of many of the famous restaurants.

Coming up in August we have the Choo Choo show in Chattanooga of which I plan to attend this year. And then of course we have the Warner Robins parade and show in October.

REFLECTIONS FROM THE SEAT OF AN OLD TRACTOR

“Don't pick a fight with an old man. If he is too old to fight, he'll just kill you.”

VCE Monthly Meeting Minutes

The June meeting of the Vulcan Corvaire Enthusiasts met on Friday, June 20th at Fullness Christian Fellowship. A potluck dinner with goods provided by the membership preceded the business. With 16 members in attendance, Joe reported a balance of \$433 in the treasury.

The possibility of the August meeting being held at the Choo-Choo event will be discussed at our July meeting. A new member has sent in their

July 2014



membership form and yearly dues; welcome Bruce Bizzoco and his wife Kathy to the group! Business talk was concerning cruise-ins, upcoming car shows, the Choo-Choo event, Warner Robbins and Maggie Valley. It looks like a busy year for the VCE members! Russ mentioned his recent visits to see both Buck and Bob. Doc reported on his new hydrographic process for car parts; call him for details. Harold asked about silicone fluid and a discussion

Next Meeting:

Date: Friday, 18 July, 2014

Time: 7:00 PM

Place: Fullness Christian Fellowship Center, 2575 Columbiana Rd, Vestavia Hills, Al 35216

In This Issue:

Upcoming Events.....	(2)
Choo Choo Registration.....	(3)
Choo Choo Peoples Choice.....	(4)
Tech Tip.....	(5)
Fultondale Cruise-in.....	(6)
Classified.....	(7)
Vintage Aftermarket Carbs.....	(8)

Upcoming Events!

July 21-25, 2014 CORSA International Convention, Tacoma, WA.

Hosted by 'Corvanatics'. Join us for "Corvair Expo" where the LeMay Automobile Museum will be the center of convention events as well as displays and activities celebrating the Corvair. Host hotel is Hotel Murano in Tacoma, 888/862-3255, mention "Corvairs" or CORSA" for special \$109 room rate.

August 15-16, 2014 Choo Choo Corvair Classic, Chattanooga, TN

Hosted by Choo Choo Corvair club. Pre registration deadline is July 25th.

See registration form in this issue, pages 3 & 4

October 3-4, 2014 Vairs at the Fair, Warner Robins, GA.

Sponsored by Heart of Georgia Corvairs Friday Night hospitality, Saturday we lead the parade into the Georgia National Fair and display our Corvairs. Saturday night dinner will be catfish and shrimp. Host Motel, Days Inn & Suites, 215 Margie Drive, Warner Robins, Ga. 478 953 6866.

Ask for Corvair Club rates of \$59.00.

Info. contact Lillian Law 229 883 4123 cell 229 291 0567 or lawjandl@aol.com.

Send Oil Drop submissions to:

GTOChief@gmail.com

Office: 256-839-1905

Cell: 256-404-5998

NOTE: PLEASE SEND SUBMISSIONS NO LATER THAN THE 25TH OF THE MONTH.

BULLITT MCQUEEN

Who: Randy Stuart

What: 7-year-old Labrador Retriever

Where: White Lake, NC

Why: Because we like dogs who like cars here at CC. Randy's Lab, Bullitt, loves riding in his '66 Chevrolet Corvair. With a RAJAY turbo-charger on the 165ci Flat-6, the air-cooled Chevy is making 220 hp with 10 psi of boost. That will keep Bullitt's ears flapping in the breeze.



Russell Noble found this in the July issue of CarCraft magazine.

2014 Great Plains
Corvair
Round Up

A Corvair Society of America sanctioned Mini-convention

Branson, MO

September 30-
October 4

Clark's
Corvair Parts®
(413) 625-9776



American
Flat 6
Corvair Performance
(210) 823-2879

2014 Choo Choo Corvair Classic Registration Form

Hosted by Choo Choo Corvair Club
August 15-16, 2014

AT THE HISTORIC CHATTANOOGA CHOO CHOO, CHATTANOOGA, TN

Name: _____ Spouse: _____
 Address: _____ Phone: _____
 City: _____ State: _____
 Email: _____ Zip: _____
 Club Affiliation: _____
 Names of Children in your group: _____

***** PRE – REGISTRATION DEADLINE: JULY 25, 2014 *****

You must be registered to take part in any event

Registration Fee: \$15.00 per person or \$30.00 per family*
 Friday thru Sunday (pre-registration) \$ _____
 \$20.00 per person or \$35.00 per family*
 Friday thru Sunday (on-site registration) \$ _____
 \$8.00 per person or \$16 per family*
 Saturday only (pre-registration) \$ _____
 \$10.00 per person or \$20.00 per family*
 Saturday only (on-site registration) \$ _____

**Family = 2 Adults and their children under 18*

Vendor Fee: \$10 per table (outside spaces only) \$ _____

People's Choice: \$8.00 per car (pre-registration) \$ _____

\$10.00 per car (on site registration) \$ _____

Awards Banquet and Choo Choo \$33.00 per Adult (pre-registration) \$ _____

Dining Room \$36.00 per Adult (on-site) \$ _____

Buffet:

Total Amount Enclosed: \$ _____

Please make checks payable to: Choo Choo Corvair Club

Tour Registration: (pre-registration preferred to assure admittance for all)

Coker Museum: Friday, August 15 th @ 2:00pm	Yes <input type="checkbox"/>	No <input type="checkbox"/>
Ladies Tour: Friday, Aug. 15 th @ 2:00 pm	Yes <input type="checkbox"/>	No <input type="checkbox"/>
Int'l Towing Museum Tour: Saturday, Aug. 17 th @ 2:00	Yes <input type="checkbox"/>	No <input type="checkbox"/>
Hot Chocolatier Tour: Saturday, Aug. 17 th @ 2:00 pm	Yes <input type="checkbox"/>	No <input type="checkbox"/>

-----Please complete information on both pages of this form-----

People's Choice Registration:

Vehicle

Description: Year _____ Color _____ Model _____

- Check all that apply:** Early Open Early Closed (including wagons)
 Late Open Late Closed
 Forward Control Specialty

Note- Choo Choo Member's Cars will be on display but not judged in People's Choice.

Liability Clause: Entrants and participants by execution of this form release and hold harmless Choo Choo Corvair Club, Inc., Choo Choo Corvair Club members and officers, Chattanooga Choo Choo, Inc. and anyone else connected with the management or presentation of this show from any and all known damages, injuries, losses, judgments, and /or claims from any causes whatsoever that may be suffered by any entrant or participants to his or her personal property (including family members and friends)

Print Name

Print Name

Signature of Registered Guest

Signature of Registered Guest

Date

Please submit registration and payment to:

Choo Choo Corvair Club, Inc.
c/o Sandra McClintock
Box 77
Georgetown, TN 37336

For online Registration: Submit completed forms to choochoocorvairclub@gmail.com
and pay via Paypal by visiting <https://sites.google.com/site/choochoocorvairclub/>

For more information, please contact:

Jim Guider, Chairman
(423) 242-8155
Guide1158@comcast.net

Melvin Hopkins, Treasurer
(706) 217-5123
Hopkins.melvin@gmail.com

“Like” us on Facebook @ [facebook.com/ CHOO CHOO CORVAIR Chattanooga Tn](https://www.facebook.com/CHOO-CHOO-CORVAIR-Chattanooga-Tn)

FULTONDALE Cruise-in



Corvair

Once again this month, A good turnout of VCE Corvairs at this Saturday night cruise-in.

Russell's convertible continues to impress the ladies, and Chris's restoration continues to look more and more impressive

The stable of running and driving Vulcans is growing. Great job folks!

Along with these pictures, Russell included the one below entitled "MEAN VAIR" and an explanation: "Dude at work took this pic a while back using infrared and regular technology and then somehow mixed it to this. Looks surreal."



Vulcan *Corvaire* Enthusiasts



40th Anniversary 1974-2014

Classifieds



Vulcan Corvaire member Richard Cleveland has parted out a 66 Monza and asked me to pass this along.

<i>Complete 140HP engine, 4 spd drive train w/suspension:</i>	<i>\$600</i>
<i>Complete Telescopic steering wheel shaft and assembly:</i>	<i>\$600</i>
<i>Complete front suspension including very good condition brake hardware:</i>	<i>\$150</i>
<i>Miscellaneous parts available:</i>	<i>Just ask (interior is 'trashed')</i>

Also for sale is his '66 Corsa Convertible with recently serviced engine and tranny, new power top and interior with telescopic steering wheel. He is asking \$10,000 and can provide sequential hard copy pictures of the restoration upon request. He does not have internet access so copies of the pictures will be mailed via USPS.

*Richard lives in North Alabama and can be contacted any time at:
256 287-2461 (cell) or 256 595-3448 (home)*

Birthdays

Ed Keller – July 2

Russell Noble – July 17

John Cleveland – July 26

**John and Denise will celebrate their
ANNIVERSARY on July 29th**

CORSA is now on [Facebook](#)



Corvaire Society of America - CORSA
The International club for all things Corvaire!

CORVAIR



6 CARBURETOR SET UP CM. -10-D



8 CARBURETOR SET UP CM. -10-E



SLIDE VALVE CARBURETOR



AIR CLEANER SET UP

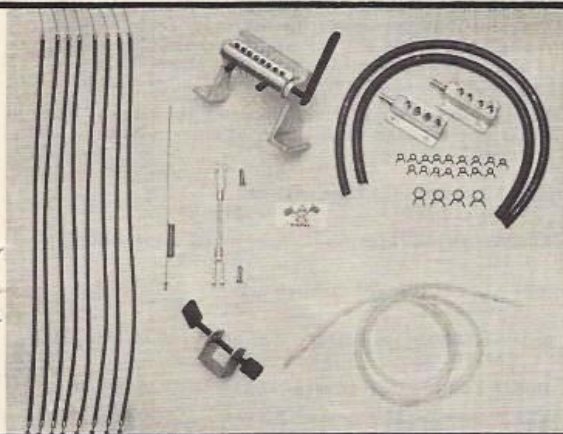

ROPAL

3156 N. San Gabriel Blvd., So. San Gabriel Calif., PH: Cu 3-6047

Speed Equipment by **ROPAL**

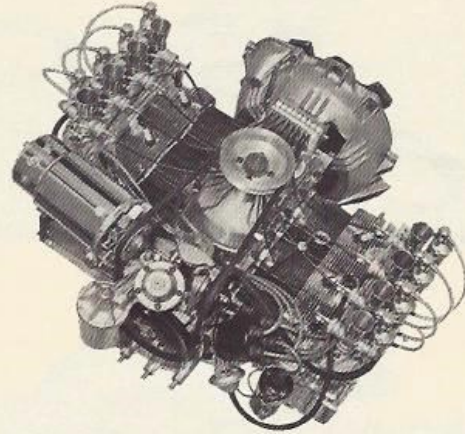

INJECTOR FIRE MANIFOLD - STREET OR COMPETITION

The new ROPAL injector Fire Manifold, six or eight carb, gives tremendous boost to the Corvair engine. These manifolds bolt on to a pre-welded bolt flange.

Note: (Refer to cylinder head section of catalogue for bolt flange installation.)

Note: On chart, power curve is taken with ROPAL Injector Fire Manifold bolted on to a completely stock Corvair engine.

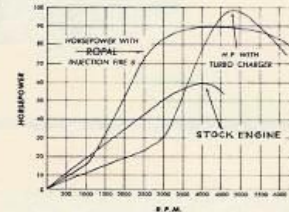

1. Six carb set complete with linkage drum, fuel blocks, gas lines and fittings, less carbs. \$111.85 Part # CM. -10-D
2. Eight carb set up complete with linkage, cables, drum, fuel blocks, gas lines and fittings, less carbs. \$119.95 Part # CM. -10-E
3. Slide valve carb, including velocity stack, one only. \$17.95; sets of six, \$11.95; sets of eight, \$10.95 each.
4. Air cleaners. Precision made screw on type to fit new slide valve carb. \$4.75 each, or in sets of six \$25.50; sets of eight \$32.00. Part # CM. 10-F

LINKAGE KIT AND FUEL LINE KIT
Note: This kit, shown in picture to be used on passenger car application.

Vulcan Corvair Enthusiasts, a chapter of the Corvair Society of America, is a non-profit club dedicated to the preservation and restoration of the Corvair automobile.

VCE dues of \$20/year pay for a family membership and 12 issues of the Oil Drop Newsletter.

President: Richard Stolzmann 205/467-6444 Vice President: Pete Wood 205/956-6832 Secretary: Russ Thuleen 205/678-7979 Newsletter Editor: Billy Cannon 256/839-1905 Treasurer: Joe Dougherty 205/995-0131

Hospitality: Harold Hartline Arrangements: Judi Cannon



THE OFFICIAL NEWSLETTER OF THE VULCAN CORVAIR ENTHUSIASTS Vol 35, No 8 & 9

THE PRESIDENT’S COLUMN:

End of Summer 2014

The Choo Choo Classic event was on August 15-16th. I wasn't able to make it due to family illness.

I hope those that went had a great time. No meeting in Birmingham as it was in Chatanooga.

At our July meeting we were a little slim as far as attendance, but the food was still really good. We didn't have gas drawing as Billy and Judi Cannon were out of town.

On another note I finished pulling the rest of the dash and wiring harness out from under the dash on my 4dr project car. I hope I can remember where the air conditioner hose goes as it is a tight fit. I just need to remove the trunk and engine compartment seal and then I can prime and straighten out any chips and dents in the body. I will paint under the dash and the ceiling and the whole inside of the car with an anti rust paint. I also replaced two studs that hold the stainless steel trim that were missing around the front and back window. I will cut the slots for the right rear fender mounted air conditioner condenser. See the pictures in this or the next issue of the Oil drop. I hope to see everyone at the Birmingham meeting on September 19th .

There will be food vendors, flea market, a band and the downtown stores will stay open late. Ed Keller reported that the Dixie Vintage club helped start the event.

Russell Noble presented hand outs of pictures of a '62 Spyder convertible he spotted off Hiway 119. The email was sent to the club and should be in the next newsletter. Pete Wood will try to contact the owner for more details.

The August VCE meeting was not held at the Choo Choo Classic due to low attendance.

Motion to adjourn was made by Clyde Cork and seconded.

Next Meeting:

Date: Friday, 19 September, 2014

Time: 7:00 PM

Place: Fullness Christian Center

STRENGTH FOR A MAN'S HEART

“God did not write solo parts for very many of us. He expects us to be participants in the great symphony of life.”
--Donald Tippett--

VCE Monthly Meeting Minutes

Meeting was called to order by Pres. Richard Stoltzmann. Richard presented Russell Noble and John Cleveland with Birthday cards for their July birthdays.

Old Business

Discussion on the board reviewing and commenting on the by-laws. The officers present will meet with John Cleveland at the close of the meeting for their comments.

New Business

John Cleveland reported on a trip to Wetumpka, AL with Russ Thuleen and Billy Cannon to see a Corvair collection that is part of an estate. There are also an extensive number of parts. These will be coming up for sale in the near future after the parts are inventoried. The seller is still deciding on how to sell the parts, as a lot or separately. There is a car show at Helena, AL the first Friday of the month as part of a community get together by the city.



In This Issue:

Upcoming Events.....(2)
 Tech Tip.....(3)
 Birthday & Anniversaries.....(4)
 Classified.....(5)
 2015 Convention.....(6)

Upcoming Events!

September 19-20, 2014 Tennessee Corvair Show, Kingsport, TN.

Hosted by East Tennessee Corvair Club

Awards for eight classes and the best of show will be presented. Also featured 1950s-60s entertainment.

Host LaQuinta Inn, 10150 Airport Parkway off I-81 exit 63 in Kingsport, 423/323-0500, ask for the Corvair rate of \$59 double or \$65 king plus tax.

Phone: 423/245-2723

October 3-4, 2014 Vairs at the Fair, Warner Robins, GA.

Sponsored by Heart of Georgia Corvairs

Friday Night hospitality, Saturday we lead the parade into the Georgia National Fair and display our Corvairs. Saturday night dinner will be catfish and shrimp. Host Motel, Days Inn & Suites,

215 Margie Drive, Warner Robins, Ga. 478 953 6866.

Ask for Corvair Club rates of \$59.00.

Info. contact Lillian Law 229 883 4123 cell 229 291 0567 or lawjandl@aol.com.

October 10-11, 2014 Vairs in the Valley, Maggie Valley, NC.

Hosted by CORSA/N.C.

Smoky Falls Lodge, 2550 Soco Road, Maggie Valley NC, 877/926-7740. Registration at ncmountaincorvairs.com.

Phone: 828/626-3617

Email: fivcent@tds.net

Send Oil Drop submissions to:

GTOChief@gmail.com

Office: 256-839-1905

Cell: 256-404-5998

NOTE: PLEASE SEND SUBMISSIONS NO LATER THAN THE 25TH OF THE MONTH.

Russ' Washington Trip

On my trip to Washington state, I stayed with my longtime friend Ray in the Portland area. We had originally planned on driving his Corvairs to Tacoma for the convention, but a week before his wife Judy called and informed me that Ray had a stroke. She asked that I come for my visit anyway. I arrived a week before the convention and helped Ray begin his therapy. He had no use of his left side and to make matters worse - the day before his stroke he had fallen and broke his little finger on his right hand. Needless to say his right hand had to be put in a cast. At the hospital they exercised his left leg and I did it at night at home. By the weekend he could walk with a cane if someone was there to support him. We left Tuesday for Tacoma and I wheeled Ray around in a wheelchair. He was greeted warmly by his clubmates. We came home to Portland on Thursday and back to rehab. At the convention Al and Joan Birk won 3rd place in their class and 3rd in the economy run with 38 MPG.

I had stayed 3 weeks in Portland and was glad to be home. Upon my arrival back in Alabama, I cleaned up my black convertible and that Thursday I took off for the Choo Choo event. There were about 45 Vairs on show and again the Birks took a prize. Vulcan members present were: Clyde and Brenda, Joan and Al, Leslie and Jessica in addition to myself.



Clark's
Corvair Parts®
(413) 625-9776



**American
Flat 6**
Corvair Performance
(210) 823-2879

Tech Tip Trivia
Can you identify these parts?

VCE President, Richard Stolzman sent in these two pictures. (hint, hint)



VCE Corvairs At Work

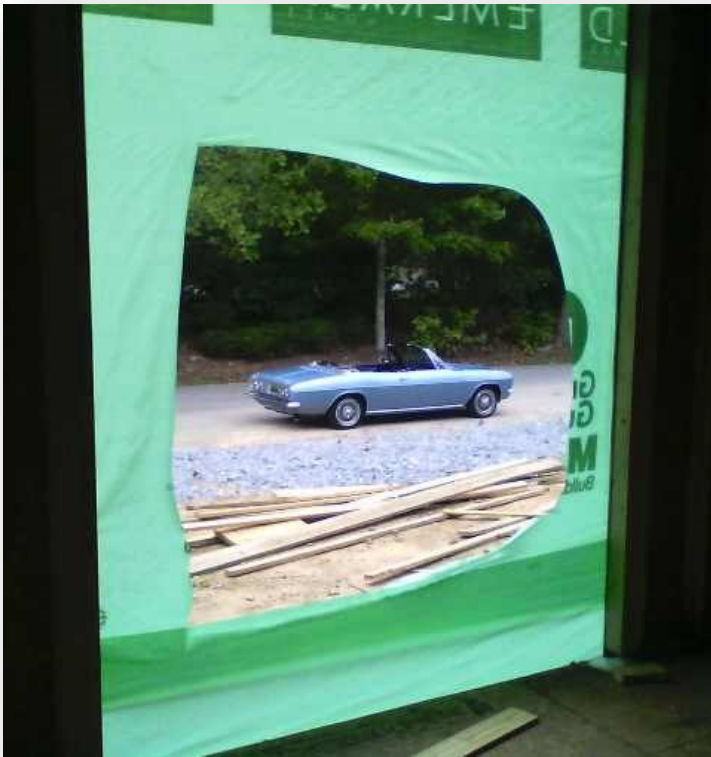

Russell Nobles Corsa 'vert at a house under construction.

Richard also passed this along:
“As you know I had a ignition switch problem (see last two issues of the OD)!
Here is the fix for the immovable part of the switch.
Drill two small holes in the burnt part of the switch, insert two paneling nails and take a pair of pliers and rotate the contact so new surfaces will be used. “

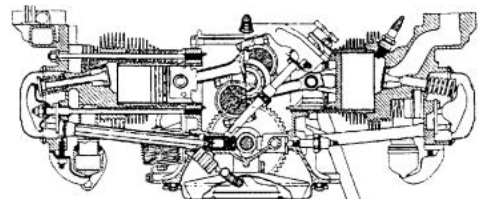
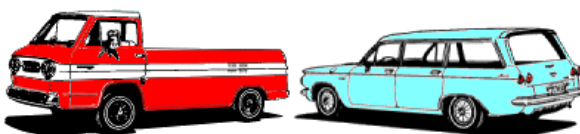



Brenda and Clyde Cork with their '64 Spyder at the 2014 Choo Choo Classic

Happy Birthday

- Judi Cannon – Sep 10
- Buck Hinkle – Sep 11
- Caroll Hartline – Sep 22

Corvair

Happy Anniversary

- Harold and Louise Hartline – Aug 1
- Jerry and Sarah Smith – Aug 8
- Ed and Carol Keller – Sep 27

**Motor Trend Design Contest 2001
(Imagine 2002 Model of an old Car)**



Corvair is Back To the Future

Amr Abdo

Classifieds

Russell Noble; "Stumbled on a 62 yesterday parked at the end of a long driveway on 119 near Leeds. Risked my life to get these not so good pics. Car looked very nice to me. No price and did not get phone number, but the address is 2856 Cahaba Valley Road (Hwy 119) between Lake Purdy and Zeigler Road."



Vulcan Corvair member Richard Cleveland has parted out a 66 Monza and asked me to update his advertisement:

<i>Complete 140HP engine, 4 spd drive train w/suspension:</i>	<i>\$600 (SOLD)</i>
<i>Complete Telescopic steering wheel shaft and assembly:</i>	<i>\$600(SOLD)</i>
<i>Horn button for telescoping steering</i>	<i>\$50</i>
<i>Complete front suspension including very good condition brake hardware:</i>	<i>\$150</i>
<i>Miscellaneous parts available:</i>	
<i>2 Left, 1 Right LM front doors</i>	

Also for sale is his '66 Corsa Convertible with recently serviced engine and tranny, new power top and interior with telescopic steering wheel. He is asking \$10,000 and can provide sequential hard copy pictures of the restoration upon request. He does not have internet access so copies of the pictures will be mailed via USPS.

*Richard lives in North Alabama and can be contacted any time at:
256 287-2461 (cell) or 256 595-3448 (home)*

CORSA is now on [Facebook](#)

Vulcan Corvair Enthusiasts



Birmingham, Alabama
Corsa Chapter. 352



Corvair Society of America - CORSA
The International club for all things Corvair!





Vulcan Corvair Enthusiasts, a chapter of the Corvair Society of America, is a non-profit club dedicated to the preservation and restoration of the Corvair automobile.

VCE dues of \$20/year pay for a family membership and 12 issues of the Oil Drop Newsletter.

President: Richard Stolzmann 205/467-6444 Vice President: Pete Wood 205/956-6832 Secretary: Russ Thuleen 205/678-7979 Newsletter Editor: Billy Cannon 256/839-1905 Treasurer: Joe Dougherty 205/995-0131

Hospitality: Harold Hartline Arrangements: Judi Cannon



THE OFFICIAL NEWSLETTER OF THE VULCAN CORVAIR ENTHUSIASTS Vol 35, No 10

THE PRESIDENT’S COLUMN:

October 2014

The September meeting at The Christ fullness center was a little sparse. But the food was good. We had our monthly gas money drawing and Louise Hartline won \$27.00.

Harold Hartline had a five minute tech session on a gas tank sender that Clarks sells, and showed us where it was leaking gas out of a solder joint. He said that Clark's sell a stainless one for around \$55.00 that is really nice. I have since ordered one. The next big event coming up besides Maggie Valley is the Warner Robins event that the Corvairs lead the parade to officially open the State Fair.

STRENGTH FOR A MAN'S HEART

It's a wise man who profits by his own experiences, but it's a good deal wiser one who lets the rattlesnake bite the other fellow.

VCE Monthly Meeting Minutes

The September meeting was called to order by President Richard Stolzman at the Fullness Christian Fellowship on Friday, September 19th. There were 11 members in attendance. The Treasurer's Report was given and there is now a \$409.40 balance in the club account. Being no Old Business, Richard called for New Business and Russ Thuleen gave a report on upcoming car show/events: Maggie Valley, NC
Tannehill Ironworks State Park, McCalla, AL car show
Lineville, AL car show at Veteran's Memorial Park first Sunday of November. Always over 900 cars, craft booths and automotive swap meet. Raffle tickets were received from the Palm Springs, CA club for their annual Corvaire Fan Belt Toss & Swap Meet. If interested in purchasing one, call Russ Thuleen. -
Current edition of Hemmings Classic Car maga-

zine has a feature on Chevrolet Concept cars in the past. Most of the vehicles were Corvaire platform concepts. Annual Christmas party was mentioned and will be discussed further at the October meeting. No further business was presented and by unanimous vote the meeting was adjourned. Harold Hartline held a short tech session on Corvaire gasoline sending units.

Next Meeting:

Date: Friday, 17 October, 2014

Time: 7:00 PM

Place: Fullness Christian Center



In This Issue:

Upcoming Events.....(2)
 Tech Tip.....(3)
 LM Stereo Front Speakers(4)
 Miscellaneous(5)
 2014 Fireball Run(6)
 Great Plains Roundup(7)

Upcoming Events!

October 10-11, 2014 Vairs in the Valley, Maggie Valley, NC.

Hosted by CORSA/N.C.

Smoky Falls Lodge, 2550 Soco Road, Maggie Valley NC, 877/926-7740. Registration at ncmountain-corvairs.com.

Phone: 828/626-3617

Email: fivcent@tds.net

October 18, 2014 8th Annual Hackneyville Community CAR SHOW, Hackneyville, AL.

50/50 * Money Tree * Concessions * Goody Bags.

Lynn Causey

Email: lynncausey@charter.net

November 2, 2014 Lineville Car Show and Swap Meet, Lineville, AL.

256-396-2058. www.claycochamber.com. Admission charged; under 12, free. Lineville Recreation Park, Hwy. 9 - Acres of antique cars, street rods, and more. 9 a.m.-4 p.m..

Phone: 828/626-3617

Email: fivcent@tds.net



2014 Corvair Affair @ St. Augustine, FL SCHEDULE OF EVENTS

Friday, October 31, 2014

4:00pm – 9:00pm Hospitality, St. Augustine Outlet Mall Community Room

(This Mall is the one on East side of I-95 toward St. Augustine)

4:00pm – 8:00pm Vending, Outlet Mall

5:00pm – Set up Model Car Display in Community Room

6:00pm – Welcome evening meal in Community Room

8:00PM - Valve Cover Races – Hallway of Outlet Mall

Saturday, November 1, 2014

7:00am Car Cleanup area available (Behind North end of Mall)

8:00am Registration in Community Room in Outlet Mall

8:00am – 5:00pm Vending, Outlet Mall

9:00am – Noon People's Choice Car Display, North end of Mall Parking Lot

9:00am – 10:30am Autocross Tech- Car Display Area - Outlet Mall

12:15pm – Late Tech Inspection – First Coast Tech Center

1:00pm - ??? Autocross @ First Coast Tech Center

6:30pm – Awards Dinner at Community Room

Sunday, November 2, 2014

Travel Home

If you will have a trailer: There is limited space at the hotel for trailer parking. You may be able to park behind the mall but will need to fill out a mall request form. Please ask Sarah for one to be included with your registration form (**the mall management needs these back at least a week before show**). Thanks.

Send Oil Drop submissions to:

GTOChief@gmail.com

Office: 256-839-1905

Cell: 256-404-5998

NOTE: PLEASE SEND SUBMISSIONS NO LATER THAN THE 25TH OF THE MONTH.



Tech Tip Trivia
Can you identify these parts? (Continued from last issue)



Well here are the pictures of where the two pieces of metal look like after they are painted the correct color (which is the color of the body of the car). The car they go on are from the look of it is the early production 65 Air Conditioned car. The assembly manual that I have for the 65 and 67 do not show two pieces of metal, and according to Russ Thuleen his air condition car did not have the two pieces of metal but as in the assembly manual on page UPC 64 sheet A3 item (#8 baffle upper) one piece of metal to keep the water from entering the evaporator when outside air was selected on AC cars. Here are some pictures of the metal pieces and where they are mounted.

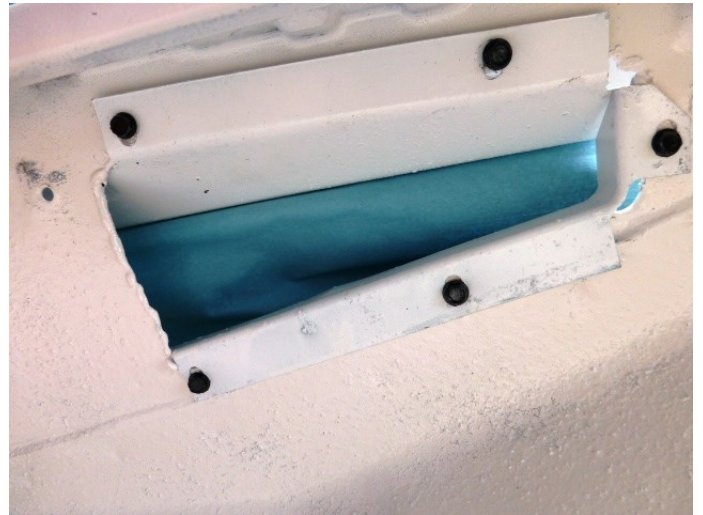
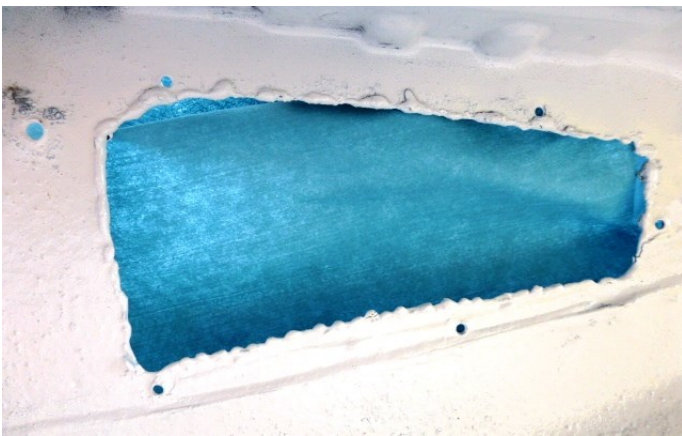
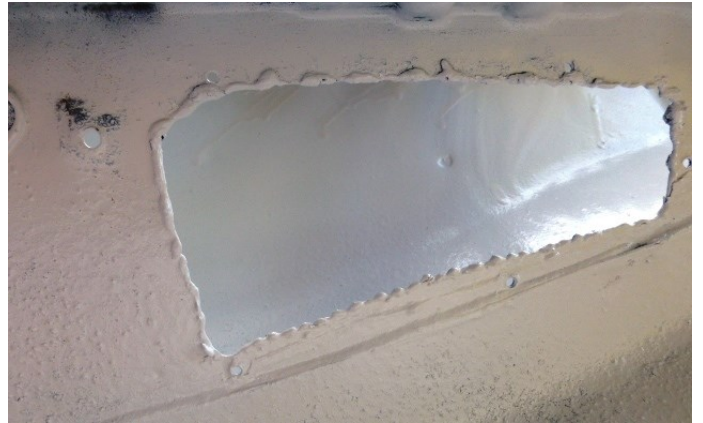

Halo and Halogen headlamps. Great appearance and nighttime visibility

Tech Tip
Late Model Front Stereo Speakers (Richard Stolzman)



I added two 5 1/4 speakers to my front original factory speaker frame. I picked them up on Amazon . com for \$18.95with free shipping, they are rated at 35 watts. The two added speakers easily fit inside and in the rear of the metal speaker frame. the original speaker had a 2 3/4 depth and the two speakers have a 2 5/8 depth, enabling me to use the original factory hold down. Included are the pictures of it mounted. The picture of the speakers showing through the grill are before the grill cloth was installed on the speaker assembly.



Vulcan Corvair Enthusiasts



Birmingham, Alabama

Corsa Chapter. 352



The 'REAL' cars. Judi and I took these pics while in Bran-son for the Great Plains Roundup.



Corvair Picnic

Happy Birthday
 Phil Hartline – Oct 8
 Rozelle Doughty – Oct 10
 Debbie Noble – Oct 14
 Harold Hartline – Oct 27

Russ, Judi and I attended the Heart Of Georgia and Corvair Atlanta Picnic and Swap Meet a couple of weeks ago at the Georgia Indian Springs State Park. We brought the Vulcan Corn Hole game for all to enjoy and as always had a good time and ate some wonderful food.

Happy Anniversary
 Judi and Billy Cannon – Oct 30



My Uncle Joe's 1961 '409' Impala restoration was just completed. He is the original owner and he says it is better than when he drove it off the showroom floor in 1961





During the latest Business/Pleasure trip to Missouri, Judi and I stayed in the St. Robert, Missouri, Hampton Inn. The Fireball Run participants also had rooms at the same hotel and the cars were parked in our parking lot. Here are some pictures I took of some of the most interesting:



Doc & Reba (Clara) Nigh pilot the DeLorean Time Machine from Back to the Future.



Stan & Peter, 'The Patriots' are in their third year of the event with this '61 Ford Ranchero..



CORSA is now on [Facebook](#)

Corvair Society of America - CORSA
The International club for all things Corvair!



GREAT PLAINS Round-up, Branson Missouri



Vulcan Corvair Enthusiasts, a chapter of the Corvair Society of America, is a non-profit club dedicated to the preservation and restoration of the Corvair automobile.

VCE dues of \$20/year pay for a family membership and 12 issues of the Oil Drop Newsletter.

President: Richard Stolzmann 205/467-6444 Vice President: Pete Wood 205/956-6832 Secretary: Russ Thuleen 205/678-7979 Newsletter Editor: Billy Cannon 256/839-1905 Treasurer: Joe Doughy 205/995-0131

Hospitality: Harold Hartline Arrangements: Judi Cannon



THE OFFICIAL NEWSLETTER OF THE VULCAN CORVAIR ENTHUSIASTS Vol 35, No 11

THE PRESIDENT'S COLUMN:

November 2014



I missed the October meeting as we were on vacation in Florida, We visited my sister in Hudson, then went to Key West, and after that visited my wife's brother in Rock Ledge Florida. We were gone ten days, glad to be home.

Coming up this weekend, November 2nd is the Lineville car show.

Next meeting is November 21st, don't miss it.

STRENGTH FOR A MAN'S HEART

To every man there comes in his lifetime that special moment when he is figuratively tapped on the shoulder and offered that chance to do a very special thing unique to him and fitted to his talents.- Winston Churchill.



VCE October Meeting

The meeting was called to order by Secretary Russ Thuleen at the Fullness Christian Fellowship on Friday, October 17th. Those in attendance were: Russ, Russell Noble, Billy & Judi Cannon and Harold & Louise Hartline. Louise won the \$26.00 Gas Raffle. Harold brought some excellent chili for the potluck which went well with Judi's meatballs and Russell's pizza.

Russ and Harold reported on their trip to Maggie Valley and even though small in number, we thought that it a good idea to pursue the possibility of having our Christmas Party at the Fullness Christian Center. It was agreed to turn things over to John Cleveland for scheduling with the Center.

Next Meeting:

Date: Friday, 21 November, 2014
 Time: 7:00 PM
 Place: Fullness Christian Center

CONDOLENCES: To John Cleveland on the loss of his Dad who passed away Friday the 22nd of October. John and Denise are in Oklahoma. Please remember them in your thoughts and prayers as they go through this time of grief.



Our Birthday and Anniversary list is 2 years out of date! If you would, please send your information to me so that I can update our roster.

In This Issue:

Upcoming Events.....(2)
 Electric 'Vair(3)
 Evolution(4)
 My Fair Valley(5)
 Vairs @ The Fair(6)
 1-Adam-12(7)
 Classifieds(8)

Upcoming Events!

November 2, 2014 Lineville Car Show and Swap Meet, Lineville, AL.

256-396-2058. www.claycochamber.com. Admission charged; under 12, free. Lineville Recreation Park, Hwy. 9 - Acres of antique cars, street rods, and more. 9 a.m.-4 p.m..

Phone: 828/626-3617

Email: fivcent@tds.net

November 8, 2014 Bill Nichols State Veterans Home 9th Annual Veterans Day Cookout & Car Show, Alexander City, AL.

256-329-8518. Show time 9am—until, Cookout at 10:30 am

Registration ends at 10am and is \$12 pre and \$15 day of the show.

April 24 and 25, 2015 "Springfest 2015", 31 years of Corvairs in Helen, Georgia.

Sponsored by Corvair Atlanta, Heart of Georgia and Queen City Corvair Clubs

All of the usual events as we celebrate our 31st year. Auto Cross, V. C. races and hospitality party on Friday. Saturday Concours, People's Choice, and more. Motels: Helendorph River End 706-878 2271, \$99.00 per night 2 nights, \$74.00 per night for standard rooms 2 nights minimum for all rooms. Best Western 800-435-3642, \$ 69.00 standard rooms, \$89.00 suites. Super 8, 800-535-1251 \$59.00 per night, Saturday night only \$69.00. All reservations should be made before March 15, 2015. Information Lillian Law, lawjandl@aol.com, 229 883 4123, cell 229 291 0567.

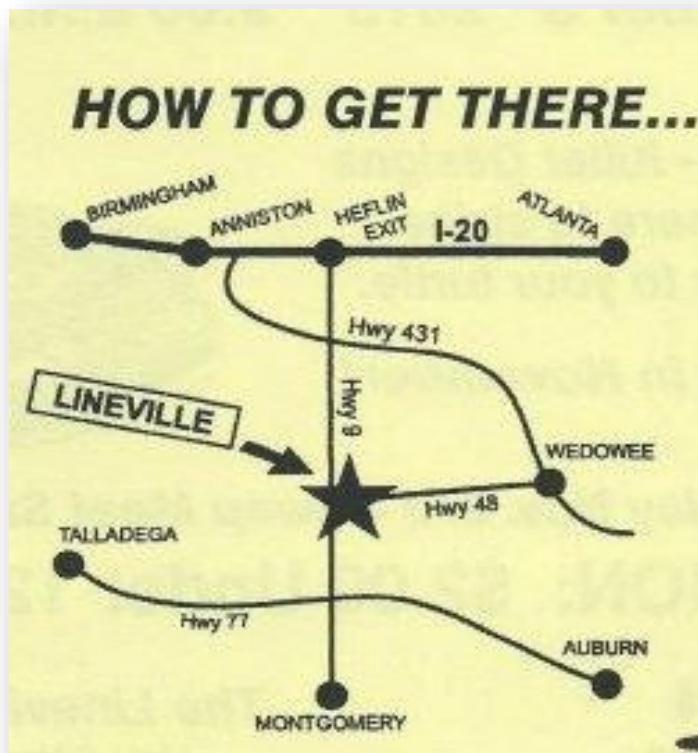

Send Oil Drop submissions to:

GTOChief@gmail.com

Office: 256-839-1905

Cell: 256-404-5998

NOTE: PLEASE SEND SUBMISSIONS NO LATER THAN THE 25TH OF THE MONTH.

Happy Anniversary

Debbie & Russell Noble – Nov 29

Happy Birthday

Steve Daniels (belated)– Oct 24

Joe Doughty – Nov 20

Roy Dutton – Nov 28



Congratulations to Pete and Emily Wood. They held a wedding dedication ceremony at the park on Saturday the 18th of October.



How about an ALL electric Corvair???

The High Voltage Hot Rods Electrovaair III is one of the best performing Corvairs on the road. Using an AC50 motor mated to a 2 speed Automatic Powerglide transmission, this car really gives a smooth ride.

High Voltage Hot Rods starts off with a clean restored 1965-67 Corvair Monza Convertible and removes the engine and other ICE components. A powerful 8" AC motor is then mated to the automatic powerglide transmission. With a 21kwh pack this can get from 70-80 miles per charge. A larger pack for additional range is available as an option. This is a complete kit including all of the major parts, brackets, adapters, motor, and controller to do a conversion. Other stores offer kits but leave many out many important and expensive components. Our kit is complete. Just add batteries.

The AC50 system is a great system for

daily drivers. It provides more power and torque than the original stock Corvair motor and includes features such as regenerative braking. The performance curves and how the car drives can be easily modified by reprogramming the controller with the optional hand held programming unit. The controller comes pre-programmed from our shop with the settings we have found work best.

This kit will include:

- ◆ 96-120 Volt Curtis AC Speed Controller
- ◆ Main contactor
- ◆ Moto Adapter to Powerglide Automatic Transmission
- ◆ Motor Mounting Bracket
- ◆ Motor Coupler - AC50 to flex plate
- ◆ Steel Battery Box Mounting Rails for engine compartment- Requires welding in
- ◆ Plans for battery boxes

- ◆ High Voltage Shielded Cable and connectors
- ◆ Digital Voltage and amp hour meter
- ◆ Battery Charger
- ◆ Elcon PFC 5000 Charger
- ◆ J-1772 Public Charging Plug
- ◆ Complete multimedia instructions including video and photos

Not included in the \$11,291.00 price is main battery pack, battery management system, and battery boxes. Photo shows optional 21kwh pack. Battery Pack can be designed and configured separately depending on range requirements. A typical pack consists of 34 - CA180 CALB Lithium Cells which yields a 70 -80 mile range. Longer range packs can be configured. Battery boxes and lithium cells can be purchased pre-configured from High Voltage Hot Rods as an option. Detailed instructions for a 21kwh pack is included.



Evolution of a Vulcan Club Car '66 Monza (Billy Cannon)

Original Classified ad, MARCH 2004

FOR SALE

1966 Corvair Monza:

The car has had **all bodywork done** and is ready for paint. **Brakes** have been completely redone with **new tires** also. The engine will run but it needs a starter bendix and one carb needs an accelerator pump. There are new carpets and headliner with the car. It is a **2 door coupe with auto and A/C!**



Here is a shot of Mickey and Harold unloading the car at the Hunter household, June 2004

NEW CAR IN THE STABLE

By Mickey Hunter

Reprint from April 2004 Oil Drop. Ed.

While Harold and Louise were in Mobile for the Azalea Run, they contacted Blake Moore about his '66 corvair coupe. I advertised the car in last months Oil Drop. Harold told me the car was sound but will require complete reassembly after painting. The car has had all bodywork done and is ready for paint. Brakes have been completely redone with new tires. The engine will run but it needs a starter bendix and one carb needs an accelerator pump. There are new carpets and headliner with the car. It is a 2 door coupe with auto and A/C! I was afraid the car might end up in the scrap yard so Harold and I are going to get the car Tuesday March 13. I'll let everyone know how the trip turned out and keep you updated on restoration.

I bought this car from Mickey and Robin back in the middle of August 2012. Russ rebuilt both carbs (still needs the starter bendix) but it will start and run under it's own power. My son Shawn made arrangements to have it painted for me as a Christmas present. *Ed.*

After 2 years of 'not-so-patient' waiting the Monza is now out of the paint booth and is ready for reassembly. Many thanks to Mark Wood of 'ShowTyme-SelfMade' for his meticulous attention to detail in the sanding and prep of the body. Many hours were spent before the gorgeous 'Go-Mango' color was laid down.

Once again Russ was kind enough to drive down and help to get it loaded and placed safely in the building.

This is going to be my winter project with hopes of having it ready for the Corvair Lover's Holiday in February. I will certainly welcome any club members assistance that would like to join me with many 'tech-tip' opportunities. Stay tuned for progress pictures and updates.



Corvair Version of "My Fair Valley"

By: Molly Bacon

We went to Vairs at the Fair also. I've attached pictures from that, too. Doesn't Russ ever give you reports on these things? Vairs at the Fair - October 3-4 Every year the first Saturday of October, there is a parade that goes from downtown Perry to the fairgrounds for the Georgia National Fair. The Corvairs lead the parade and are to only vehicles allowed into the fair itself and end up being displayed at the edge of the lake on the side of the midway. As you can see, it was a beautiful day and the people really enjoyed seeing all the Corvairs. There was a good showing of FCs plus yours truly's FC of a sort, the Ultra Van. The event actually starts

Friday with a swap meet and dinner at the host hotel and wrapped up Saturday night with a Catfish and Shrimp dinner. This is a fun event with great people. I only have pictures of Russ' Shorty and our Ultra Van

Vairs in the Valley, Oct 10-11, Maggie Valley, NCAs always, the North Carolina group does an outstanding job putting on this great fall show. They added an autocross this year on Friday. Having to work, we did not get up in time to see the autocross. Heard it was a success. The weather threatened us all day. Rain drizzled once and then later there was a pretty good, but short shower. This did not dampen anyone's spirits or the People's choice display. Unfortunately, it did cause

the valve cover races and the slow drags to be canceled. Because of the rain, I did not get many pictures. Missed getting Russ' car. Sorry, Russ. Interesting spectator, we had a quick visit by Dale Walksler (Wheels through Time Motorcycle and Car Museum). He was riding one of his old Harleys. I have to brag as the Ultra Van took first place in the Specialty class. Unfortunately, we also got the Hard Luck award after an unexpected encounter with a fire hydrant. You need to put this show on your "must attend" list.



'Vairs at the Fair Pictures by Richard Stolzman



Great pictures Richard, and congratulations on the \$100.00 door prize.

1-ADAM-12, See the Man...

"I was watching Adam-12 on Netflix (Season 1, Episode 19) and saw Malloy and Reed pull over a Corvair. Lo and behold it was Otis from Andy Griffith - driving drunk. Hmm, how did he get from Mayberry to LA? Looks like a 67-up Monza. Watching old shows is fun!"

Russell Noble



(Editors NOTE)

Otis, 'Hal Smith', did a lot of voice actor work as well as live action. One of the scarcer cartoons he did was Space Angel.

This was done by the same people that did Clutch Cargo and used the senco-vox method where the cartoon character had the real actors lips speaking through the face.

His character on Space Angel was said to have influenced the creation of the 'Scotty' character from Star Trek.

CLASSIFIEDS

From Al Birks;

"I have some news that members of Vulcan Corvairs might be interested in. Last Saturday I attended the MOTAA International Car Meet in Burnsville, MS. I entered my 1963 Spyder Convertible and managed to get a Senior Award for the presentation. MOTAA presents a metal badge that can be attached to your grill or license plate at this level.

Aside from showing my car, there was another Corvair present at the show. It was a 1960 4-door sedan in excellent condition. I talked to the owner and he said he was interested in selling the car, which has been in his family for a number of years. Here is the information on this car:

- ◇ 1960 Corvair Model 700 4-door Sedan
- ◇ 41,000 original miles
- ◇ Original engine recently upgraded with higher compression pistons - estimated HP is now 100 hp. (I did not check on transmission type: manual or automatic??)
- ◇ Interior has been redone with blue cloth and it looks brand new
- ◇ Exterior paint is a blue and it in excellent shape.
- ◇ No body dents or rust
- ◇ Everything works - absolutely no repairs required
- ◇ Bumper chrome front and rear is excellent
- ◇ Dual outside mirrors
- ◇ Wire wheel covers
- ◇ Stone guard over headlights
- ◇ Front and rear spoilers - front nicely integrated with body (these are the only changes)
- ◇ It even has a Corvair tissue dispenser installed as an option
- ◇ A gas heater was provided with this car, (owner says it works, but it is disconnected since not required)



The owner is a retired auto mechanic, who is skilled with working on Corvairs and other cars. He is interested in working on Corvairs if someone needs repairs, tune-ups, etc.

He said he was asking \$12,000.00 for the car.

If we know of anyone who would like to become a Corvair owner or any member would like to add another Corvair to their collection, this car should be considered. They can contact the owner, Dan Decker, at 731-608-4492. He lives in Finger, TN, which is south of Jackson, TN, which is about 30 miles north of Corinth, MS."

Russell Noble inquired about some tires and rims that he saw in the 'Various Matters' newsletter. The owner of the 1969 Monza Convertible is Rob Fields and provided the following:

Falken "Road Hugger GT ECO" 205 50R 16"

Rims are American Racing "Torque Thrust PVD" 16X7 5-120.6

Approximate Total Cost = \$1300

Rob says: "15" also looks good on this car. But, I just wanted to go up in size. 17" is tight, and overly bold. I have seen both on the 'Late' Corvair. But, as they say, to each his own!"



Vulcan Corvair Enthusiasts, a chapter of the Corvair Society of America, is a non-profit club dedicated to the preservation and restoration of the Corvair automobile.

VCE dues of \$20/year pay for a family membership and 12 issues of the Oil Drop Newsletter.

President: Richard Stolzmann, 205/467-6444 Vice President: Pete Wood, 205/956-6832 Secretary: Russ Thuleen, 205/678-7979

Newsletter Editor: Billy Cannon, 256/839-1905 Treasurer: Joe Doughty, 205/995-0131

Hospitality: Harold Hartline Arrangements: Judi Cannon



THE OFFICIAL NEWSLETTER OF THE VULCAN CORVAIR ENTHUSIASTS Vol 35, No 12

THE PRESIDENT'S COLUMN:

It looks like Christmas is almost here!!! John Cleveland has got the 'ok' for us to have our Christmas party on Saturday December the 13th at our usual monthly meeting place. (Fullness Christian Fellowship church) We will eat around 1 PM, so plan on arriving around 12 noon. Members need to contact Carol Keller to find out what to bring. Billy Cannon will be providing the HAM and Denise Cleveland the TURKEY. We were a little slim at our last regular meeting, November 21st, but the food was really great, and Russ Thuleen won the \$12 Gas Money Drawing. Reminder that Dues will be due and it will be time to elect new officers at the Christmas Party.

STRENGTH FOR A MAN'S HEART

Sign on a Scottish golf course "Members will refrain from picking up lost golf balls until they stop rolling."

VCE October Meeting

The November meeting of VCE was held on Friday, November 21st at Fullness Christian Fellowship. There were 15 members in attendance. The usual potluck dinner preceded the business portion of the meeting. There was plenty of OLD BUSINESS to discuss; starting with the trips to Wetumpka that Billy, Russ and John have been making to check out the vehicles/parts for sale by David Bailey. They found lots of good stuff! David currently has a '64 Coupe with Wire wheels for sale. See Billy, Russ or John for more information. Speaking of Corvairs for sale, Charley Drake has 2

Next Meeting (Christmas Party):

Date: Saturday, 13 December, 2014
 Time: 12:00 PM
 Place: Fullness Christian Center

December 2014

vehicles currently up for sale. Contact Charley at (205) 681-9553 for more information. The topic of the Christmas party was discussed and decided it would be on Saturday, December 13th at 1pm. Billy Cannon will be providing the ham and Denise Cleveland the turkey. All other members are requested to bring a side dish, a salad or dessert. Upcoming events include a car show in Myrtle Beach in March 2015. Call or see Russ for more information. The annual VCE picnic is in the planning process and tentatively set for May 2015 (around Mothers Day). Billy Cannon is coordinating.

Happy Birthday
 Carol Keller – Dec 18
 Richard Cleveland – Dec 20
 Russ Thuleen – Dec 20

Happy Anniversary
 Wilma & Bob Siemens – Dec 17

Our Birthday and Anniversary list is 2 years out of date! If you would, please send your information to me so that I can update our roster.

In This Issue:

- Upcoming Events.....(2)
- Rustproof Part 1.....(3)
- 'Turtle'(4)
- 'Ray's Vairs'.....(5)
- 'Hackneyville'.....(6)
- Classifieds(7)

Vulcan Corvair Enthusiasts



Birmingham, Alabama

Corsa Chapter. 352

Upcoming Events!

Support your local Christmas Parades by driving your Corvair.

February 27 & 28, 2015 "30th Annual Corvair Lovers Holiday & Car Show

Host Hotel: Days Inn Pensacola Beachfront
www.daysinn.com/hotel/21564

16 Via De Luna Drive Pensacola Beach, FL 32561
850-934-3300 or 800-934-3301

Mention the "Corvair" for special rate.

Hospitality Dinner Friday Night! Out to Dinner Saturday Night! Door Prizes! 50/50! Vendors welcome outside and must register for the show! Peoples Choice "Top Three" Awards Given Out on Saturday Afternoon! Special awards: Best of Show! Longest Distance! Hard Luck Award! Sarah White Ladies Choice Award!

April 24 and 25, 2015 "Springfest 2015", 31 years of Corvairs in Helen, Georgia.

Sponsored by Corvair Atlanta, Heart of Georgia and Queen City Corvair Clubs

All of the usual events as we celebrate our 31st year. Auto Cross, V. C. races and hospitality party on Friday. Saturday Concours, People's Choice, and more. Motels: Helendorph River End 706-878 2271, \$99.00 per night 2 nights, \$74.00 per night for standard rooms 2 nights minimum for all rooms. Best Western 800-435-3642, \$ 69.00 standard rooms, \$89.00 suites. Super 8, 800-535-1251 \$59.00 per night, Saturday night only \$69.00. All reservations should be made before March 15, 2015. Information Lillian Law,

Each year the membership collects money at our Christmas party to give to a local charity. This year we have received news that Jeff Barrett, past President of his home club, CORSA / NC will be making a drive in his 1965 CORSA from the Atlantic Ocean to the Pacific Ocean to raise funds for the Make-A-Wish Foundation. During his trip he will be taking part in the Route 66 Fun Run. National automotive magazines will also pick up the story as well as other media sources along the way. This will provide wonderful national attention to the Corvair as it helps this wonderful cause. Plans for the money we raise at our party are to donate it to Jeff's cause and help the Make-A-Wish Foundation. If you do not know anything about Make-A-Wish check them out online at www.Wish.org.

Send Oil Drop submissions to:

GTOChief@gmail.com

Office: 256-839-1905

Cell: 256-404-5998

NOTE: PLEASE SEND SUBMISSIONS NO LATER THAN THE 25TH OF THE MONTH.



Part 1 on how to rust proof your late model Corvair

The first thing to do is remove the (outlet assembly), or the (panel, shroud plastic) that's what GM calls the plastic assembly that holds the vent door in the front and on each side of the front doors, or the fresh air vent. It needs to be removed so all the leaves and other stuff that has turned into sludge from exposure to water, It will hold water and then rust through in front of the front doors. There are 4 sheet metal screws that hold it in. remove these four screws and the panel will with a little effort pull out. The carpet should be behind it. Then you will see that GM used a liberal amount of soft caulking to seal against the entry of water into the car. You can reuse the caulking with a little effort, it should be still soft, except for a little dust or lint on it, you can wash the dirt or lint off with soapy water. then scrape it off the body and

panel assembly and knead it together in a big ball so it can be reused. Clarks sells a 3M Strip-caulk pn C3201, or you can go on line under amazon.com or Google.com and search on 3M Strip-caulk, and find it. If you decide to reuse your old caulking it needs to be kneaded in to a ball, then rolled in to strips about 3/8 in in diameter, then put on the body or the plastic kick piece and then the panel needs to be inserted into the hole after the crud is cleaned out. The sheet metal screws have a small head on them so a large washer needs to be put between the head of the screw and then they need to be slowly screwed in to let the caulking spread out to seal the opening. You might have to use a longer screw at first to reach the metal of the body. You should do this when it is warmer or use a heat gun on the metal to warm it up and then insert the panel. Once the panel is in

place you can assist the spreading out of the caulking by pushing on the panel with your foot. Make sure you use some padding so you don't scratch or mar the panel. Next month we will look in the opening and see the crud and remove it.

Richard Stolzman



*Turkel wins again!
November 15, Plains, Georgia.*



No, Jimmy Carter did not make it this time, but unlike the last time we went, something we own took Best of Show in Class. The Ultra Van was put in the stock truck class with six nice stock trucks. There were only classes for Cars, Trucks, Street Rods and Motorcycles. This was a judged show, not people's choice. Not sure what the judging criteria was, but really was shocked when they called Chris' name for Best of Show in the class. Here are some pictures.

Chris and Molly and Turkel (aka Ultra Van #328)



Corvair

#328

The Life of a Corvair Enthusiast

Bill Warren
Decatur, AL

(Concerning the '62 Rampside)

Glad to see that the Rampside found a good home. If you get it on the road Gerg, you will be the third person to ever drive the Rampside. The previous owner was my friend Ray. He kept almost every car he ever owned. The Rampside originally belonged to his uncle and spent its first life in California. Ray was medically retired from the Air Force in 1971 after 18 years as a F-86, F-100 and F-4 jet mechanic. MIGs killer COL Robin Olds had Ray to thank for keeping his

aircraft in the air out of Ubon, Thailand during the Vietnam War. Ray was promoted to Chief Master Sargent for his ability to spot “cheaters”, “slackers” and “misfits” and keep them from wrenching on jet aircraft. This got Ray called on the carpet many times by the Air Force but the brass understood that this is the kind of guy you need when trying to keep jet fighters in the air. Falling off the wing of an F-4 at “Eddie’s Patch” put Ray out of the Air Force early. None of the more than a dozen Corvairs that Ray owned were drivable. Ray had a maintenance plan for every one of his Corvairs and had an extensive parts stash ready. It was very difficult to get Ray to part with any of his parts. “I’m going to need that for the 64 over there”. Even if a Corvair drove into his shop under its own power there was always some reason to start a repair that meant dis-



assembling the car. At the age of 80+, Ray was still doing engine and suspension work in his 40x60 well equipped shop with cars double stacked on lifts. The only thing that got him down was his bad back from falling off of the F-4 and his many proclaimed Agent Orange maladies. I used to ask Ray if he would consider selling me the Rampside. He would always drag out an Old Cars Price Guide which would force me to pass. Regrettably, I’m not allowed to have any more Corvairs follow me home. Anyway, I’m glad Ray’s Rampside found a good home. I think Ray used the price guide as his way of not selling any of his cars. Ray had an emotional attachment to all of his Corvairs, especially the Rampside. Ray thought he had many more trips out to the garage left but I don’t think he wanted to complete any of his projects. Hope the Rampside hits the road soon. Ray will be watching.



Ray with his friend David Bailey, who has been handling the sale of Ray’s collection after his death.

'Hackneyville'



Judi and I were finally able to attend a car show this year. This is a great 'Small Town' event only 14 miles from our home. 29 cars from the Birmingham Corvette club (and many others) drive all the way down to get a little 'Mayberry' hospitality every year. Ya'll Come!



John Cleveland's convertible on an early morning in Oklahoma.

CLASSIFIEDS

For Sale: Corvair parts, many new in package. Various wiring harnesses, assorted boots and grommets, Shift tube bushings (plastic and bronze), front door switches, tie rod end seals, air cleaner J bolts and much more.

Email for a listing
monzajohn@charter.net
Half off vendor pricing.



Vulcan *Corvair* Enthusiasts

40th Anniversary 1974-2014

It's a White Christmas with blue trim at Yenko Sportscars, Inc.

Our Christmas present to the motoring world is the new YENKO STINGER available not six months from now, but before the New Year!

And what a delightful package the STINGER is. It's absolutely the finest rally and touring car plus a great dual-purpose race car. (SCCA Class D Production).

With better engine breathing and valve timing, horsepowers are available up to 190.* The steering has been quickened and the brakes are virtually fade-proof. The handling is something you just won't believe. We say it's the best in the world. Care to disprove it?

"BE A SWINGER IN A STINGER"

*Optional at extra cost (Stang 1 - 160 hp)
83278.55 F.O.B. Canton-Ocala, Pa.
Write for list of YENKO STINGER Distributors, c/o Dept. C, Yenko Chevrolet, Canton-Ocala, Pennsylvania.

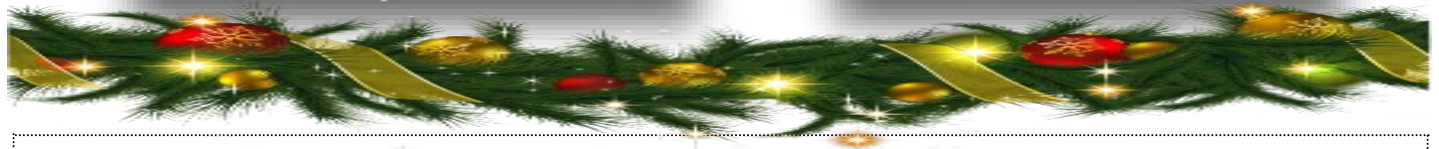

Vulcan Corvair Enthusiasts, a chapter of the Corvair Society of America, is a non-profit club dedicated to the preservation and restoration of the Corvair automobile.
 VCE dues of \$20/year pay for a family membership and 12 issues of the Oil Drop Newsletter.
 President: Richard Stolzmann, 205/467-6444 Vice President: Pete Wood, 205/956-6832 Secretary: Russ Thuleen, 205/678-7979
 Newsletter Editor: Billy Cannon, 256/839-1905 Treasurer: Joe Doughty, 205/995-0131
 Hospitality: Harold Hartline Arrangements: Judi Cannon