



THE OFFICIAL NEWSLETTER OF THE VULCAN CORVAIR ENTHUSIASTS Vol 38, No. 1

In this Issue:

- * **Blast from the Past**
- * **Vulcan Corvaire Christmas Party**
- * **Christmas Parades and Shows**
- * **Events & Ken Oakley Drawings!**
- * **Corvairs at Barber Motorsports Park**
- * **Classifieds**

2016 VCE Officers

President:

John Cleveland
monzaiohn@charter.net
 205-834-3120

1st Vice President:

Richard Stolzmann
richey-rich_43@Hotmail.com
 205-467-6444

2nd Vice President (communications):

Billy Cannon
qtochief@gmail.com
 C: 256-404-5998
 H: 256-839-1905

Secretary:

Steve Daniels
steve_d_daniels@bellsouth.net
 C: 205-213-5935
 H: 205-995-9474

Treasurer:

Russ Thuleen
 C: 205-451-9626
 H: 205-678-7979

VCE Mailing Address

Vulcan Corvaire Enthusiasts
 147 Crossbrook Dr.
 Chelsea, Al 35043

From the Prez,

As I write this I have been recuperating from my pre-Christmas flu, which my wife and I shared almost the whole week before the holiday. I'm sure between my anti virus software and Billy's this should be safe to read for all of you.

2016 is now only a week from being complete and as I'm sure you will see in this issue of looking back our club has done well for itself.

In preparation for remodeling a little in our basement I have decided to let go of my copies of the Communicue. I got an almost complete set from Buck Hinkle before he passed away and have enjoyed reading and sharing them for the last few years. Billy Cannon will be the new caretaker for this set of priceless Corvaire entertainment and technical resources. I'm sure he will make them available to the club as I have so we can all enjoy them.

After the decision to let them go, I contacted Corsa as I noticed they were missing some of the 1979 issues. I let them know the complete year was in my possession and if they wanted me to scan the missing issues for them I could do that. While scanning the word Vulcan caught my eye and somewhere in the newsletter you'll find the announcement for the fall outing to Mt. Cheaha the club used to do for several years.

Another task I'll try to complete by next meeting is to make another CD compilation of the club's collection of the Oil Drop up to this issue. Several years ago, with the help of Richard Stolzmann and Bob Siemans I was able to find and scan about 90% of all the Oil Drop issues since the club began in 1974. These are great reading and have a lot to offer in the technical area as well. These are free to all members and I'll bring them to the meeting. To RSVP you copy, send me an email.

Our officer elections will be held in January and I urge all of the membership to attend to run for office or just to make sure we have a good voting block. The Treasurer position is definitely open and will have to be filled. I haven't heard from any others on the board if

January 2017

Next Meeting:

Date: Friday, 20 January

Time: 7:00 PM

**Place: Fullness Christian Center
 2575 Columbiana Rd, Vestavia Hills, AL 35242**

they want to run again or not, but all position are open to anybody who can bribe enough people to defeat the incumbent!!!

2017 looks to be an exciting year for the club and what I consider to be a turning point for us, at least since I joined eight years ago. We have several new, active members who are willing to step up to the plate and not only attend events, but coordinate so we as a club can host an event. The Barber Motorsports weekend can and will be a great success as long as we have club participation. Start thinking now about how you can help make it successful.

Our participation in Springfest is also very exciting. Although my job consistently gets in the way, it is the one event of the year Denise and I look forward to and I always plan some vacation for that week hoping I can get all my work out of the way to make that happen. As a club we should be very proud to have been invited to participate in this event and as a club we need to participate. If you have never attended, I know you will enjoy it even if you are assigned some task to perform. We usually do something anyway just to help out, so it's never been an issue with me or other members that regularly attend.

God bless you all and our wish is that you have a great 2017 and beyond, Take care and keep that Vaire out there!!!!!!!!!!!!!!!!!!!!!!!!!!!!

John

VCE Meeting Minutes

There was no business conducted at the December meeting held at Rozzelles home.

Blast From The Past

John Cleveland found this while scanning the 1979 Communique's for CORSA:I

October 13-14

Vulcan "Vairs host Cheaha Mountain Meet

The Third Annual Cheaha Mountain Meet sponsored by the Vulcan Corvair Enthusiasts is scheduled for October 13-14, 1979.

This year's affair will follow past tradition in that it will be an easy paced Corvair family oriented event. We're looking forward to being with our friends from Atlanta, Montgomery, Chattanooga, and throughout the southeast. The club has again secured the rustic old stone lodge on top of Mount Cheaha (elevation 2407 feet, the highest point in our state) in the midst of the Talladega forest. Magnificent views of the surrounding forested country side are dominant and the fall foliage should be in blazing colors. Hiking and scenic drives are additional attractions.

The lodges and motel capacity are limited. The lodge has 15 individual sleeping rooms and one bunk room upstairs accomodating a total of 50 people. The motel (approximately 3/4 mile away) has 30 rooms but they go fast in the fall and reservations for the motel are on an individual basis. There are also cabins, chalets, and a camp ground. The number for reservations other than the lodge is 205-488-5115. The motel has a nice restaurant. The lodge is equipped with a large kitchen and dining hall with fireplace. Those staying at the lodge of course can utilize the kitchen facilities as needed. The rooms in the lodge are equipped with double beds and/or bunk beds and most share an adjacent bath.

Room rates for the lodge are \$5.00 each for the first two persons in a room plus \$3.00 for each additional person. Sleeping in the bunk room will be \$4.00 each. (Linen and bedding provided throughout)

An additional \$1.00 registration fee will cover the cost of the Saturday evening meal consisting of hamburgers, hot dogs, beans and chips. Marshmallows will be available for toasting in the fire place. The meal will be prepared by our "bonded" infamous chefs of mechanical notoriety (Fanbelt salad with Oil drip dressing). Free Tums will be available.

Schedule is as follows:

Saturday afternoon checking at the lodge; looking, gawkin' and sightseeing. (Note: if the lodge is unused Friday, early checking is permitted. If not, the other park facilities are available until checkin time).

Saturday evening - Supper or reasonable facsimile followed by narrated slide history of the Vulcan Corvair Club (approximately 8 p.m.) (Buffet breakfast available at the restaurant)

Sunday 10 a.m. - Parts swapping and trading in the "circle" in front of the lodge.

Sunday 1 p.m. - Peoples Choice Concours (\$5 per car fee) in 5 classes: (1) early open (2) early closed (3) late open (4) late closed (5) vans and trucks.

Official checkout time is 1 p.m. Sunday. Note: the weather could be chilly at this time of year at this elevation!!

Work is under way for a one hour tech session on carburetor rebuilding most likely Saturday afternoon or early Sunday. Our carburetor man is "wanted" all over Alabama! Frank Ranelli Chairman.

For information and lodge reservation contact: Ms. Bobbi Floyd 205-923-7968.



Top: Id Richard Stolzmann? Buck Hinkle's Spyder Convertible

Left: The crowd arrives to admire VCE at it's finest.

Blast From The Past Continues

Read the room rates from the 1979 article and compare with the statement below.....

Bald Rock Lodge –The original hotel and restaurant for the park built by CCC Company 2420-sp17 CV. We have the Calhoun and Talladega Chambers of Commerce to thank for the joint effort to get the lodge built and opened in 1942 at 2,100 ft. . The lodge is now used for group rentals only at the 2017 Rates

Peak Season - Fall - October & November All week & weekend rates - \$2,200 per night



From my investigation I assume that these pictures were taken within a two or three year timeframe from the date of the Communicate article. The pictures were in the 35mm Kodak slide carousel that Ed Keller and Harold Hartline maintained over the years. This carousel also contained all the slides from the 1975 Dixie Mini Convention that I have scanned and are in a separate Oil Drop article. I believe the yellow Greenbrier is from one of the Georgia clubs that often attended the Cheha Rally. Someone guessed that the Monza convertible with the sideskirts is driven by Frank Ranelli. The Forrest Green Corsa in front of the lodge is also unknown to me. I would appreciate any help putting proper names of owners and club affiliation to these fine mid seventies pictures of our beloved little cars and trucks.



Vulcan Corvair Christmas Party

Photos Courtesy of Howard Tutt

VCE Christmas Party this year was a huge success thanks to our gracious host, Rozelle Doughty. She provided the most delicious pork tenderloin I have ever tasted, lots of finger foods, adult beverages, plenty of deserts and most of all, her beautiful home all decked out in Christmas Cheer! As usual, our 'out of state' members were able to drive the long distance and we always appreciate the sacrifice that they take to be able to attend our festive get-together. Al & Joan Birks from Corinth MS and Chris Brown & Molly Bacon from Pine Mountain, GA.

Standing below George Miljus, Phil Hartline, Ed Keller, and our newest member, Marshall McDuffie



Danny Joe Robertson from Toney, Al also has quite the trip and the majority of the time he drives his '64 Spyder. Leslie Thuleen and Claudia Tutt share Facebook memories.



Joyce & Linda Miller also made the trip up from Montgomery and were able to visit with long time VCE member, Sarah Smith..



Denise Cleveland in her Santa hat talks with Judi Cannon while Russell Noble and President John Cleveland share a doorway.



Russ Thuleen is pondering his next project



Steve Daniels and Richard Stolzmann politely listen in on all the current gossip.



2016 Corvair Christmas Parades and Shows

by Billy Cannon



We started the season off in my home town of Goodwater Alabama. As Russ is wont to say; "A good place to live." The show was arranged and executed by my good friend Bernard and his fellow Buffalo Soldier MC Club. The shuttling of the Corvairs from the storage building to the show field went like clock work and we were set up and running with registration numbers 14-18. For those that are counting that is two trucks, two Monza coupes and one Corsa coupe. I didn't even attempt to register my Corvair bicycle with all the Harleys and Goldwings in attendance. It was a successful attempt at their first show and many lessons were learned that will make it a promising event for 2017.

I have to say that Howard Tutt deserves the most enthusiastic VCE member award when it comes to decorating and participating in this years seasonal parades and shows. His attention to detail and ingenuity of attaching the lights and garland to his Monza are amazing. But I learned after the fact that he had a little help from a close family member. The more the merrier!



Leeds was the first parade that we participated in and it was on a cold Friday night. The 'Navy Rampy' has not received it's gas heater yet so I drove over with one of those little 12v cigarette lighter heaters that worked surprisingly well in the close quarters of the cab.



Santa was right in front of the four Corvairs riding in the back of a '59 El Camino. The Leeds parade had to be the most favorite this year for this writer. A Great turnout and one of the friendliest crowds ever!



The crowd and cars were also out the next day for the 'Toys for Tots' car show.



(Continued on page 6)

(Continued from page 5)

Howard and I were the only Corvairs in attendance amongst a sea of Mustangs. As usual, Howard walked away with a wealth of 'neat' door prizes while all I won was a cutting board in the shape of (you guessed it) a Mustang.

The following Saturday was the famed Chelsea Parade that VCE has been a faithful participant for several years. As usual, Russ registered us as a group with an anticipated five vehicle count but we were only able to produce the two trucks and one coupe. The weather threatened to spoil our parade but it held off long enough to please the crowd.



Russ and 'Shorty'. Always a favorite for any crowd. Jesse had duties as candy thrower.



VCE prestaged as entry number 67. Attendance was down because of the threat of rain but still good numbers!

L to R: COMNAVCORVAIRFLT ('62 Rampy), SHORTY ('61 Loadside), King Tutt Mobile ('66 Monza Coupe)



Howard navigates through the ever increasing crowd as the reviewing stand looms closer. By this time we were all out of candy.





WORLD'S LEADING MANUFACTURER OF

Automotive Replacement Carpet

Nothing makes a bigger impact to the interior of your Corvair like replacing the carpet!

PROUD SPONSORS OF:



Corvairs at
BARBER
MOTORSPORTS PARK

Birmingham ALABAMA



May 26-27 2017

For details contact Vulcan Corvair @ 256-839-1905 or <mailto:atochief@gmail.com>

Date	Event	Place
2/17-18/2017	Corvair Lovers Holiday	16 Via De Luna Pensacola Beach, FL 32561
4/28-29/2017	SPRINGFEST	Edelweiss Strasse Helen, GA 30545
5/26-27/2017	Corvairs at Barber	Barber Motorsports Park & Museum

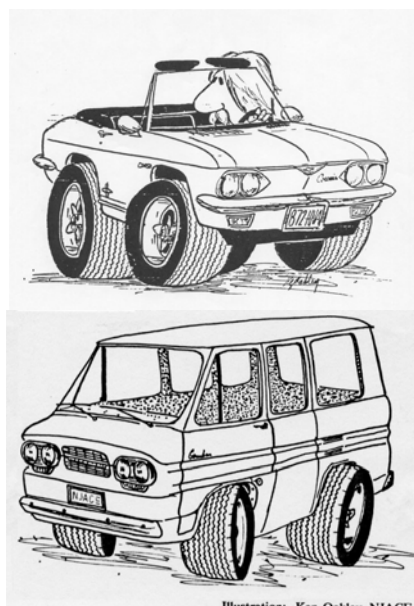
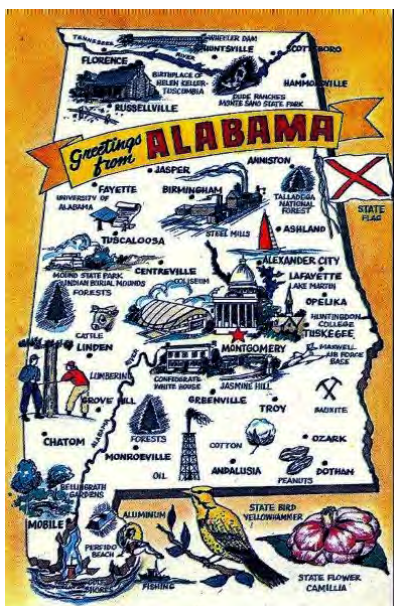

Illustration: Ken Oakley, NJACE



Danny Robertson has been graciously providing signage to the club. Here are some of his products and prices:

- 6X8 Plaques, Mouse Pads, Car Tags and Coffee Cups.....\$10ea.
- 3” Magnets.....\$3ea.
- 5” Magnets.....\$5ea.



BLACKBELT Taekwondo & Awards
 4556 Jeff Rd.
 Toney, Al 35773 (256) 859-3737
 (256) 509-2236
 Email: dannyjoerobertson@outlook.com

Our 42nd Year!

Get the 2013-2018 Catalog

If you did not get the catalog in 2013 or 2014, you can get one **FREE** on your first **\$50 order** during 2015. (Additional catalogs \$3 with an order)

Over 100 new repro parts in the past 3 years.

Clark’s Corvair Parts®

400 Mohawk Trail, Shelburne Falls, MA 01370
 (413)625-9776 www.corvair.com

Send Oil Drop submissions to:

GTOChief@gmail.com

Office: 256-839-1905

Cell: 256-404-5998

VCE IS on Facebook...Click on the link:

[Vulcan Corvair Enthusiast FB Page](#)

NOTE: PLEASE SEND SUBMISSIONS NO LATER THAN THE 25TH OF THE MONTH.

Vulcan Corvair Enthusiasts, a chapter of the Corvair Society of America, is a non-profit club dedicated to the preservation and restoration of the Corvair automobile.

VCE dues of \$20/year pay for a family membership and 12 issues of the Oil Drop Newsletter.



THE OFFICIAL NEWSLETTER OF THE VULCAN CORVAIR ENTHUSIASTS Vol 38, No. 2

In this Issue:

- * **Things That Can Happen When Cold**
- * **Tech Tips**
- * **Seat Covers**
- * **CORVAIR LOVERS Holiday**
- * **SPRINGFEST 2017**
- * **Corvairs at Barber Motorsports Park**
- * **Classifieds**

2016 VCE Officers

President:

John Cleveland
monzaiohn@charter.net
 205-834-3120

1st Vice President:

Richard Stolzmann
richey-rich_43@Hotmail.com
 205-467-6444

2nd Vice President (communications):

Billy Cannon
qtochief@gmail.com
 C: 256-404-5998
 H: 256-839-1905

Secretary:

Steve Daniels
steve_d_daniels@bellsouth.net
 C: 205-213-5935
 H: 205-995-9474

Treasurer:

Howard Tutt
hftutt@yahoo.com
 936-524-7611

VCE Mailing Address

Vulcan Corvaire Enthusiasts
 147 Crossbrook Dr.
 Chelsea, Al 35043

From the Prez,

Welcome to 2017! So far we've had ice storms and floods, trees blown down and intense lightning. What a way to start the new year!

Our first meeting is in the books and the first order of business was the election of officers. The lineup is the same as last year with the exception of the Treasurer's position. Welcome Howard Tutt as our new Treasurer.

The updated Oil Drop CDs are available free of charge to any club members. This is a compilation of most of the newsletters published since the club's inception in 1974.

Since they are free you'll need to come to a meeting to get one; there is no free shipping. If you want one sent to you, email me or give me a call and we'll work something out.

Several of our members attended the Springfest planning meeting in Forsythe, GA the Saturday before our club meeting. Event chairmen were finalized and the rounding up of volunteers began. For those of you that are thinking of going and want to help out contact me, Billy, Russ, Howard or Danny for more information. You can help a little or a lot; all help is appreciated.

Also, if you are going, we have been asked that each man bring Ruffles potato chips each lady bring a dessert. Sheet cake or dessert bars are recommend as easiest to serve. That seems to be a little gender specific to me, but we can work it out. I'm specifically thinking of some of the great stuff Danny brings to our pot luck dinners!

We are also well underway for the Vulcan Corvairs at Barber event. Everything should be finalized by the February meeting and we will start filling volunteer slots for that event. Stay tuned and start thinking about how you can help make this club event a success. It promises to be very exciting and has generated a lot of interest in the area.

The Feb. meeting date is the same weekend as the Corvaire Lover's Holiday in Pensacola, and the next club meeting will be held in Pensacola. I'm not sure how many members of the board will be there, but I'll find somebody to steer the ship for us as I will be working over in the Savannah, GA area. There will be

February 2017

Next Meeting:

Date: Saturday, 18 February

Time: TBD

Place: Corvaire Lovers Holiday Days Inn, 16 Via De Luna Dr. Pensacola, Fl

a lot of information and finalization for the Barber event completed at that meeting.

I found some very interesting things happening to the convertible with the colder temps. Look at the article on page three about some things you might want to check out on your car if you are doing any cold weather driving. Also, I just ordered my steering box rebuild kit from Clark's so stay tuned for an article about what not to do! Russ is pretty good at keeping me straight but sometimes I think he let's me screw up just so he can get a laugh out of it,

Take care and keep that Vair out here!!!!!!!!!!!!!!
 John



Danny Joe's finished seat covers. See the installation on page 4

VCE Meeting Minutes

Call to Order

After our customary pot luck dinner, the meeting was called to order January 20, 2017, at 7:34 PM by President John Cleveland.

(Continued on page 2)

VCE Meeting Minutes (cont.)

Participants

With 15 members in attendance, a quorum was present.

Minutes of the Previous Meeting

Minutes were distributed prior to the meeting for review.

Financial Report

Below is the financial report from Treasurer, Russ Thuleen. As a reminder, this information will not be in the version of the minutes published in *The Oil Drop*.

Income	Expenses	Balance
2 Dues Payments: \$40	Church Rental: \$75	\$560

The check that was written to Leeds Baptist Church as a deposit for the Barber event has not been cashed and is *not* reflected in the above balance.

A motion to accept the financial report was made, seconded, and passed.

Dues for 2017 are now due. To make a payment, please send your check to our new Treasurer:

Howard Tutt
1945 Linden St.
Leeds, AL 35094

Election of Officers

The following officers were elected for calendar year 2017.

Office	Nominees	Result	Vote
President	John Cleveland	John Cleveland	By Acclamation
1 st Vice President	Richard Stolzmann	Richard Stolzmann	By Acclamation
2 nd Vice President	Billy Cannon	Billy Cannon	By Acclamation
Treasurer	Howard Tutt	Howard Tutt	By Acclamation
Secretary	Steve Daniels	Steve Daniels	By Acclamation

Events

Future Events

Date	Event	Place
2/17-18/2017	Corvair Lover's Holiday	Pensacola, FL
4/28-29/2017	Springfest	Helen, GA
5/26-27/2017	Corvairs at Barber	Barber Motorsports Park & Museum

Corvair Lover's Holiday

Seven members plan to go to the Corvair Lover's Holiday in Pensacola.

Past Events

Vulcan Corvair Christmas Party

The Christmas party at Rozelle's was a great success. Our thanks go to Rozelle for her hospitality and generosity.

Committee Reports

Southeast Corvair Picnic / Corvairs at Barber

Our contact with Barber Motorsports Park is on a sabbatical. It was confirmed with her manager that Corvairs at Barber is a go for the dates and activities as previously planned, including a controlled lap of the track. Museum entry will be available. Barber can supply a photographer for a fee.

There is a parking area for us at the track as well as at the hotel.

Howard Tutt discussed selling banners as advertisements. The church banquet hall is reserved; their committee passed us. The Hampton Inn is committed.

The Hemmings advertisement is running both online and in the magazine starting next month. The CORSA Communiqué has the ad paid for by our sponsor Auto Custom Carpets as well as appearing on the CORSA events page.

Other clubs are publicizing the event. We got good ideas from the Springfest planning meeting.

Lillian Law will run registration and will need help. Food and prizes have yet to be arranged. T-shirts are still an open item. The source for Springfest has agreed to do t-shirts for us at the same rate as she does for Springfest. There was a discussion of the quality of shirts last year and this year's improvements.

John Cleveland asked that the details on financials, advertising, and food be worked out by the next meeting.

Clyde Cork said that Bernie's from Montevallo will do the Saturday night meal catered for \$15/person (estimated) for 2 meats, 2 vegetables, tea, soft drinks, and the set up (plates, flatware, etc.). There was a brief discussion of alternatives. The membership of both Vulcan Corvair and our partner, Choo Choo Corvair, will need to commit resources to this to be successful.

Springfest

Nine members from Vulcan Corvair participated in the planning meeting last week. Planning for this event is meticulous. John Cleveland passed out the list of Springfest committees. Setup starts at noon on Thursday. Registration is the most labor-intensive piece.

President's Report

CORSA has announced new procedures for Chapter's staying current and responsibilities for the chapters to CORSA. Russ Thuleen paid VCE's fee to CORSA on time last year.

Old Business

Carol Keller will give Howard Tutt a receipt for the flowers for Rozelle Doughty and the club will reimburse her as previously agreed.

New Business

John Cleveland distributed CDs of all the copies of *The Oil Drop* since 1974.

Harold Hartline noted that the activities at Springfest and Barber may change the nature of the club's income as a social club. John Cleveland will make inquiries with an attorney on that point.

Tech Session

We did not have a tech session tonight.

Drawings

The calendar was won by Danny Robertson. Gas money of \$34 was won by Danny Robertson.

Next Meeting

The next meeting will be February 17 or 18 at the Corvair Lover's Holiday in Pensacola since so many members will be there.

Adjourn

The meeting was adjourned at 8:17 PM.

Happy Birthday
Louise Hartline – February 23

THINGS THAT CAN HAPPEN WHEN IT GETS COLD!!

John Cleveland

My car has always been a little hard to start in cold weather, but this winter when it finally did get cold, it got really hard to start. There were two things going on, one a nuisance that could get expensive, and one dangerous that could get; well, dangerous.

Let's start with the dangerous one first. I'm sure you've all heard about the thermal properties of dissimilar metals. Your furnace and some oven thermostats work off this principle. When heated and/or cooled, dissimilar metals expand and contract at different rates. The effect on screwed connections can range anywhere from annoying to life threatening. For instance, my primary carburetor connection, where the fuel line nut connects to the filter nut on the carb. The reason my car would just crank and crank in the morning was because when the weather got cold it caused the tension from the fuel line nut connection to loosen the filter nut connection on the carb. This resulted in a gas leak which would empty the gas from the fuel regulator to the carb as well as the fuel in the carb bowl. To start the car I'd have to crank up the oil pressure to close the switch to the electric pump, then pump up the system to fill the carbs. That's a lot of cranking, and enough gas leaking while the engine is running to cause some concern.

Lesson learned; do a visual inspection of your engine compartment on a routine basis and every time something unusual starts occurring with your car.

Now for number two. Still with the dissimilar metals thing, if you don't know about the purple wire, I'll tell you some about it. There is a connection in the engine compartment that goes to the starter (see picture at right). After 50 years or so this connection gets corroded and loose. What the purple wire does is direct current to the starter when you turn the key. This is a LOT of current. When the connection gets corroded it starts cutting the current off which caused the starting solenoid to cut out for a split second. This is just enough time for it to disengage, then reengage the starter to the flywheel. If you've ever heard this noise it is something you'll never forget. If you haven't ever heard it, it'll scare the pants off you (if you don't believe me, look in my car. There is a pair of scared pants in there!!!).

The fix is to cut the purple wire going in to and out of the connector, then crimping a male/female connector on the ends of the wire (14 or 16 gage) and connecting them together. I tried taking my connector loose and cleaning and tightening it up, but it only lasted a couple of weeks, so don't waste your time with that.



Send Oil Drop submissions to:

GTOChief@gmail.com

Office: 256-839-1905

Cell: 256-404-5998

NOTE: PLEASE SEND SUBMISSIONS NO LATER THAN THE 25TH OF THE MONTH.

VCE IS on Facebook...Click on the link:

[Vulcan Corvair Enthusiast FB Page](#)

Top Tech Tip

Courtesy of Seth Emerson

“Ok Guys & Gals. The real scoop on U-Joint bolts:

The U-joint bolts have six marks, making them Grade 8 bolts. They are, indeed, a 1/4-20 Coarse thread (NC) and are .75" long, under the head. They have a 7/16" hex head.

GM used them in 1965 only, changing to a special 5/16 NF (fine thread) bolt for 66-up.

GM may, or may not have noticed this problem, but I have. The bolt used on the 65 was identical to the bolt used to hold down the valve cover. Except the valve cover bolt was grade (2?) - Or grade nothing . No marks on it. The bolts often got swapped when the powertrain was being worked on, putting poor bolts in a place (The U-joint) where GM intended Grade 8s (They would not have spent the money if they didn't think so). I have also found grade 8 bolts on the valve covers. Hmmm. I think I better check the U-joints!

One final note. Since Grade 8 was originally specified for this application, you should use the torque values in the shop manual. Except, I cannot find the Torque value anywhere in my 65 manual. Industry standard for those size bolts (1/4-20 NC Grade 8) is 9-12 Ft lbs. New, nicely plated bolts 9 Ft-lbs, plain or worn finish 12 Ft lbs. Using the correct values means the bolt will provide the correct clamping force, and (usually) not back out on it's own accord.

Also important. If you substitute a Grade 8 fastener for a Grade 5 - or lower - you must use the Grade 8 torque value. The stretch of the correct torque is what makes the bolt stay in place. NOTE! Pay attention to the female threads you are using. They must also be capable of handling the Grade 8 torque. If you (over) torque a grade 8 bolt into most aluminum castings, you will find out exactly how they made those aluminum threads, because they will be stuck to the bolt threads as the bolt spins in the hole and falls out. Don't be tempted to change over to Grade 8 for everything. If you can supply a Grade 8 (equivalent) nut for the backside, go for it. But don't assume any nut can take the increased torque.

-Seth

Seat Covers

by Danny Joe

I just finished my seats and boy are my hands sore! I had already stripped them down completely and primed the frames before Christmas.

All of the spring wire was rusted away (this is a 16 spring steel wire wrapped in paper). The paper wrapping helps prevent squeaks, and the wire ties the springs together. The first picture shows the bare frame with the new spring wire. These wires are the attachment points for the seams in the panels in the seat and back upholstery.



After that the frames were covered in burlap.



I had purchased a roll of felt from Clark's for the back of the seat back frames and there was enough to also put a 2" strip around the perimeter of the frames. This was a tip from one of the videos i watched, it keeps the spring edge from cutting into the cushions.

Another tip was to use cotton batting over the seat for further protection and padding. The cotton batting at Hobby Lobby didn't look very good and was pricey (\$30 for a couple of yards), but I used some polyester quilt

(Continued on page 5)



(Continued from page 4)



batting. A piece for a full-size quilt was only \$12 and was enough for a double layer.



Glued 2" strips of felt around the back of the seat backs to cushion the edges.

For some reason, I didn't take any pictures of the cushions at all! I thought I had, but oh well! In the next picture, however, the muslin on the cushion can be seen. Then the cushions were installed with a few hogrings. Positioned the seam in the cushions over the spring wires



and cut the muslin and batting in 5 spots on each side for attaching hog rings. It would be difficult to take a picture, but I will attempt to describe how the seams are attached. Sewn into each seam is a muslin tube about 3/8" in diameter. A piece of spring wire is cut to length and inserted into the muslin tube. The hog rings are used to tie the 2 pieces of spring wire together and the wire keeps the rings from ripping out of the muslin. This also keeps the seams straight and gives shape to the upholstery.

There was one other tip that was most helpful. On the seat back, I had to stretch the front of the vinyl under the bottom to cover a 2" gap. The tip was to use cable ties to draw it up until hog rings could be applied.



The finished product looked so good in the house I hated to install them!

I also made a set of seat extensions for the passenger seat so the seats will be even. Materials for 2 seats is \$55-60 from Lowe's. I could probably gotten the metal for 1/2 that if I had gone to a fab shop I know of. Used 2" wide 3/16" thick flat bar. Sorry, no picture.

Danny Joe



REGISTRATION FORM

THE 32nd ANNUAL CORVAIR LOVERS HOLIDAY & CAR SHOW
FEBRUARY 17-18, 2017

Administration Only

Ck# _____
Cash _____

NAME _____ SPOUSE/OTHER _____

ADDRESS _____

CITY _____ STATE _____ ZIP _____

E-MAIL _____ PHONE _____

**YOU MUST REGISTER FOR THE SHOW IN ORDER TO REGISTER YOUR CAR!
VENDORS ARE WELCOME OUTSIDE BUT MUST REGISTER FOR THE CAR SHOW!**

PRE-REGISTRATION, PER PERSON (BEFORE 2/6/16) (CHILDREN UNDER 10 ARE FREE)	_____ @ \$12.00= _____
REGISTRATION, PER PERSON, DAY OF SHOW	_____ @ \$15.00= _____
SATURDAY ONLY REGISTRATION	_____ @ \$ 8.00= _____
CAR REGISTRATION: FIRST CAR	_____ @ \$10.00= _____
SECOND CAR	_____ @ \$ 5.00= _____
VALVE COVER RACE:	_____ @ \$ 3.00= _____
CLUB T-SHIRTS : L, XL, XXL: (Plain or Pocket)	_____ @ \$? = _____
WFC, Inc. dues \$15:	SUB-TOTAL= _____
We will send in your CORSA dues \$45:	Dues \$15.00= _____
	CORSA Dues \$45.00= _____
	TOTAL= _____

REGISTRATION INCLUDES: NAME TAG, HOSPITALITY ROOM, FRIDAY NIGHT HOSPITALITY DINNER, SATURDAY LUNCH AND ONE (1) DOOR PRIZE TICKET PER EACH PERSON REGISTERED.

PLEASE INDICATE THE FOLLOWING INFORMATION ABOUT YOUR CAR:

1ST CAR: COLOR _____ YEAR _____

Circle One: CONVT 2DR 4DR STNWGN GRNBR RPSIDE LDSIDE MODIFIED SPECIALTY

2ND CAR: COLOR _____ YEAR _____

Circle One: CONVT 2DR 4DR STNWGN GRNBR RPSIDE LDSIDE MODIFIED SPECIALTY

MAIL REGISTRATION FORMS TO: WEST FLORIDA CORVAIR CLUB, C/O JUNE LINDSAY,
5670 SAN VAIR ST., MILTON, FL 32583, Questions? wfcc@mediacombb.net or 850-994-2161
(SORRY, NO CREDIT CARD WILL BE ACCEPTED ONLY CHECK OR CASH (CHECK PREFERABLY).)

**WE ARE GOING TO THE SHRIMP BASKET ACROSS THE STREET FROM THE HOTEL FOR SATURDAY NIGHT DINNER. WOULD YOU LIKE TO JOIN US?
(If you plan to go to dinner elsewhere circle "No.")**

YES / NO HOW MANY? _____

**The 32nd Annual
Corvair Lovers Holiday & Car Show
February 17 & 18, 2017**



2016 Corvair Lovers Holiday

Host Hotel: Days Inn Pensacola Beachfront

www.daysinn.com/hotel/21564

16 Via De Luna Drive

Pensacola Beach, FL 32561

850-934-3300 or 800-934-3301

**Mention the "Corvair" for the special rate same as last year of
\$69 Inland, \$89 Sound Side (Parking Lot) and \$99 Gulf Front**

**Pet Friendly: Paradise Inn
21 Via De Luna Drive
Pensacola Beach, FL 32561
850-932-2319**

**Pensacola Beach RV Resort
17 Via De Luna Drive
Pensacola Beach, FL 32561
850-932-4670**

Proud Sponsor of Dog and Cat Animal Rescue

**Hospitality Dinner Friday Night! Out to Dinner Saturday Night at the
Shrimp Basket located across the street from the hotel! Door Prizes! 50/50!**

Vendors welcome outside and must register for the show! Peoples Choice "Top Three!"

Awards Given Out on Saturday Afternoon! Special awards: Best of Show!

Sarah White Ladies Choice Award! Longest Distance! Hard Luck!

Registration begins at 4:00 pm on Friday Afternoon!

(Schedule of Events and trophies are subject to change.)

For more information contact: June Lindsay at 850-994-2161, wfcc@mediacombb.net

SPRINGFEST 2017

Celebrating 33 Years of Corvairs in Helen

HOSTED BY

Corvair Atlanta, Heart of Georgia Corvair Club,
Queen City Corvair Club, and Vulcan Corvair Enthusiasts

at

The Festhalle in Helen, Georgia

April 28-29, 2017

To our Corvair friends please pre-register, save money, help us plan and have a chance to win \$35.00

Concours, people's choice, car display, tech session, ladies activities, rally, slow drags, 50/50, raffle for prizes.

Valve cover races (Youth under 14 free)

Hospitality party Friday night

Friday Autocross, test and tune 10:00 a.m. to 12:00 p.m.

1:00 p.m. Autocross (must register for show and pay \$15.00 entry fee)

Car Show and a banquet prepared by our famous cooks on Saturday

Festhalle open at 8:30 a.m. Friday & 7:30 a.m. Saturday

Motel information (Ask for Corvair club rates): available April 27-29

Helendorf River Inn: phone 1-706-878-2271 \$188 (\$238 for riverfront)
for 2 nights (2 nights minimum).

Best Western: 1-706-878-2111, \$69.00 (\$89 for suites) per night
Deluxe continental breakfast included.

Super 8: phone 1-706-878-2191, \$59 per night

Country Inn and Suites: phone 1-706-878-9000, 2 Queen Beds \$99.00

Make reservations by March 30, 2017 to get Corvair rate

Check www.helengeorgialodging.com for other lodging

This year you will be able to pre-order t-shirts. This will assure that you get your shirt even if you are late arriving. We will have some available on site. The men's shirt is antique sapphire and the ladies is hellconia. Pictures will be available on the Springfest website at www.corvairspringfest.com.

Sizes: Men's – Small to 3XL \$15.00 Ladies – Small to 3XL \$15.00

We have planned a Rally this year, please pre-register so that we will have enough packets printed.

Outside spaces are limited, each space will be 2 parking spaces

For those arriving on Thursday, I have reserved a large dining room at Western Sizzler for Thursday night at 6:30 pm.

ATTENTION VCE Members:

Our club responsibilities for SPRINGFEST are for each of our ladies to bring a dessert (Sheet cakes or dessert bars are easier to serve), our men should bring a large bag of original flavor ruffle potato chips.

Event check-in is at the Festhalle.

Information: Lillian Law 1-229-883-4123 or 229-291-0567 lawjandl@aol.com

Autocross information: Billy Cannon 256-404-5998 or 256-839-1905 gtochief@gmail.com

Tentative Schedule of Events

FRIDAY APRIL 28, 2017

Registration	8:30 am - 7:00 pm	Festhalle
Auto-X Set-Up/Car Inspection	8:30am - 10:00 am	City Parking Lot - Large
Auto-X Test and Tune	10:00 am - 12:00 pm	City Parking Lot - Large
Vendors	10:00 am - 6:00 pm	Festhalle
T-shirt Sales and Ticket Sales	10:00 am - 7:00 pm	Festhalle
Car Coral & Car Clean Up	10:00 am - 6:00 pm	Helendorf Parking Lot
Autocross	1:00 pm - until	City Parking Lot - Small
Concours Safety Inspection	2:30 pm - 6:00 pm	Helendorf Parking Lot
Cash Bar	6:00 pm	Festhalle
Hospitality Party	6:30 pm	Festhalle
Valve Cover Races	8:00 pm	Festhalle
50/50 drawing	8:00 pm	Festhalle
Hospitality - After hours	10:00 pm	Upstairs Best Western
Visit Helen Merchants	All Day	

SATURDAY APRIL 29, 2017

Registration	7:30 am - 12:00 pm	Festhalle
Car Clean Up	7:00 am - 9:00 am	Best Western/Helendorf parking lots
Vendors	8:00 am - 5:00 pm	Festhalle & Helendorf
Concours Safety Inspection	8:00 am - 9:00 pm	City Parking Lot - Small
Concours Participants Meeting	9:00 am - 9:15 am	City Parking Lot - Small
Judges Meeting	9:15 am - 9:30 am	City Parking Lot - Small
Concours	9:30 am - 1:30 pm	City Parking Lot - Small
People's Choice	9:30 am - 1:30 pm	City Parking Lot - Large
People's Choice Voting	9:30 am - 12:30 pm	City Parking Lot - Large
Staff & Judges only Lunch	11:30 am - 12:30 pm	Festhalle
Participants Lunch	12:30 pm	Festhalle
<i>Until food is gone \$5.00</i>		
Slow Drags	1:45 pm	City Parking Lot - Large
Rally	2:00 pm	City Parking Lot - Small
Technical Session	2:30 pm - 4:00 pm	Festhalle
Ladies Activity	2:30 pm	Festhalle
Entertainment & Cash Bar	6:00 pm (chips & dip)	Festhalle
Banquet and Awards	7:00 pm -10:00 pm	Festhalle
Hospitality - After hours	10:00 pm	Upstairs Best Western
Car Coral	All day	Helendorf Parking Lot
Visit Helen Merchants	All day	
Door Prizes & 50/50 Drawing	All day	Festhalle
Ticket and T-Shirt Sales	All day	Festhalle





WORLD'S LEADING MANUFACTURER OF

Automotive Replacement Carpet

Nothing makes a bigger impact to the interior of your Corvair like replacing the carpet!

PROUD SPONSORS OF:



Corvairs at *Birmingham ALABAMA*
BARBER
MOTORSPORTS PARK



May 26-27 2017

For details contact Vulcan Corvair @ 256-839-1905 or <mailto:gtochief@gmail.com>

Our 42nd Year!

Get the 2013-2018 Catalog

If you did not get the catalog in 2015 or 2016, you can get one **FREE** on your first **\$50 order** during 2017. (Additional catalogs \$3 with an order)

Over 100 new repro parts in the past 3 years.

Clark's Corvair Parts®

400 Mohawk Trail

Shelburne Falls, MA 01370

(413) 625-9776 www.corvair.com

Vulcan Corvair Enthusiasts, a chapter of the Corvair Society of America, is a non-profit club dedicated to the preservation and restoration of the Corvair automobile.

VCE dues of \$20/year pay for a family membership and 12 issues of the Oil Drop Newsletter.



THE OFFICIAL NEWSLETTER OF THE VULCAN CORVAIR ENTHUSIASTS Vol 38, No. 3

In this Issue:

- * CORVAIR LOVERS Holiday The Cars
- * CORVAIR LOVERS Holiday The People
- * SPRINGFEST 2017
- * CORVAIRS @ Barber Registration
- * Blast from the Past
- * Classifieds

2016 VCE Officers

President:

John Cleveland
monzaiohn@charter.net
 205-834-3120

1st Vice President:

Richard Stolzmann
richey-rich_43@hotmail.com
 205-467-6444

2nd Vice President (communications):

Billy Cannon
qtochief@gmail.com
 C: 256-404-5998
 H: 256-839-1905

Secretary:

Steve Daniels
steve_d_daniels@bellsouth.net
 C: 205-213-5935
 H: 205-995-9474

Treasurer:

Howard Tutt
hftutt@yahoo.com
 936-524-7611

VCE Mailing Address

Vulcan Corvaire Enthusiasts
 147 Crossbrook Dr.
 Chelsea, Al 35043

Prez Says:

For most of us February marks the beginning of the car show season with the Corvaire Lover's Holiday at Pensacola Beach. For me it was another mark and one which I hope never happens again. I've been hoping this for quite a few years but will not give up. It is the marathon tech support call. Instead of getting on a plane to California on Wednesday for about a single days work I was able to convince the powers that be (otherwise known as THEM) they could send their technician out and I could work with him over the phone. THEY agreed so I waited for my phone to ring. It rang on Friday morning so we went to work, with me realizing that I could have been with the others driving down to Florida (nice weather, top down... you know what I mean!). After the battery died on my work cell phone I switched to my home cell phone and continued. It is now early afternoon. When my home cell died I switched back to my work cell phone. It is now early evening. Long story short it was one of those marathon phone session I sometimes find myself in. This one lasting about 10 hours. It was still better than a 'quick' trip to California and back, but it sure spoils the beginnings of a weekend.

The club meeting was held at Pensacola and on top of the agenda was our Barber event, which is quickly taking shape. Billy and his crew have a sign up sheet and are looking for volunteers. Contact him to find out where the open spots are and volunteer to help out. This promises to be a great event for all the clubs in our area.

Springfest is also rapidly approaching so if you haven't registered or made reservations you had better get started. I made reservations at the Best Western last week (I know the name has changed, but I can't remember what to). They were out of suites and only had a few rooms left. They definitely have the best 'Corvaire' rate of the bunch. Spring is coming so get that car in shape and get it out for all to see! The cruise ins and shows will be here before you know it Take care and keep that Vair out there!!!!!!!!!!
 John

March 2017

Next Meeting:

Date: Friday, 17 March

Time: 7:00 PM

Place: Fullness Christian Center

VCE February Meeting Minutes

Call to Order

The February 2017 meeting was called to order February 18, 2017, at 11:30 AM by Second Vice President, Billy Cannon.

Participants

With 17 members in attendance, a quorum was present.

Financial Report

The financial report from Treasurer, Howard Tutt, was read to those in attendance. He reported that as of this date, we received Barber event sponsorship payments of \$125 for T-shirts and \$100 for Banner sales. He gave total balances in both the general and Barber event funds account. A motion to accept the financial report was made, seconded, and passed.

Dues for 2017 are now due. To make a payment, please send your check to our Treasurer:

Howard Tutt
 1945 Linden St.
 Leeds, AL 35094

Committee Reports

Southeast Corvaire Picnic / Corvaire at Barber

Billy Cannon and Howard Tutt met with Ken Howell of Auto Custom Carpets for a follow up discussion of the banner and T-shirt advertising. Ken approved of the prices and reiterated that we meet with Corky Corker of Corker Tire Company in Chattanooga

The following week Russ Thuleen, Howard, and Billy met with several members of Choo Choo Corvaire at the restaurant in Dawson, GA. Choo Choo approved everything we discussed with them. Ed McClintock agreed to meet with Corky

(Continued on page 2)

VCE Meeting Minutes (cont.)

Corker to discuss a sponsorship opportunity. The following week, Choo Choo approved of everything we discussed with them and Ed McClintock agreed to meet with Corky for a sponsorship opportunity.

Clyde Cork informed the group that Bernie's from Montevallo has agreed to the price and is willing to cater the event at the church banquet hall. Members agreed that the menu that Clyde mentioned sounded very good.

There was lengthy discussion about work assignments for the event and several folks agreed to help out.

Danny Robertson finished the banners and brought them to Pensacola as display. The Ft. McClellan Credit Union sponsor logo was added.

Lillian Law attended and agreed to run registration. She discussed pointers based on her considerable experience. We discussed Hospitality Room food (Judi Cannon, committee lead) and acquiring door prizes. Members agreed to start collecting door prizes. T-shirts are still an open item.

Offline to the meeting proper, Billy Cannon, Ed Lindsay, and June Lindsay discussed the legal details concerning financials, advertising, and donations as well as past experiences conducting a large event like Corvairs at Barber.

Springfest

Lillian presented a brief status report concerning our participation in the planning and execution.

Old & New Business

There was no discussion.

Tech Session

We did a tech session on checking the condition of Corvair horns.

Drawings

We did not conduct a drawing because we knew that Richard was going to win anyway.

Next Meeting

The next meeting will be March 17 at our usual location.

Adjourn

The meeting was adjourned at 12:17 PM.



Happy Birthday
Claudia Tutt –
March 21

Date	Event	Place
3/10-11	Corvair Performance Workshop	Corvette Museum Bowling Green, Ky
4/28-29/2017	Springfest	Helen, GA
5/26-27/2017	Corvairs at Barber	Barber Motorsports Park & Museum



Send Oil Drop submissions to:

GTOChief@gmail.com

Office: 256-839-1905

Cell: 256-404-5998

NOTE: PLEASE SEND SUBMISSIONS NO LATER THAN THE 25TH OF THE MONTH.

VCE IS on Facebook...Click on the link:

[Vulcan Corvair Enthusiast FB Page](#)

32nd Annual Corvair Lovers Holiday The Cars

This year marked a record breaking SEVEN Rampsides in attendance during the three decades plus that this event has been held. Russ and I were proud to have driven two of the seven and neither gave us any trouble over the close to 600 mile round trip.

But Danny Joe did not fair so well with having to rebuild a fuel pump on his '64 Spyder at 6:30 AM on the side of the interstate and battery problems later that morning after our breakfast break at the Peach Park in Clanton. We used the 'Navy Rampy' to pull start the Spyder and then on to Pensacola.

Our little six vehicle caravan swapped leaders a few times on the way down. Howard led us into the last leg of the trip on an unusual but interesting route that got us to the hotel a little later than usual. With the exception of Turkle, we were the last to arrive.

Ed & Carol, Harold & Louise and Clyde & Brenda checked into the hotel Thursday night and enjoyed the extra day of surprisingly good Gulf Coast February weather.

WFCC has conducted this event for 32 years now and it continues to please all that have attended. For the second year we have enjoyed the added 'Corn Hole' tournament. Vulcan is pleased to have provided another set of game equipment and I think that the paint has finally dried John!



Ed & Carol Keller Early Open wins Ladies Choice



Danny Joe's '64 Spyder takes the Hard Luck and Longest Distance award.



Judi Cannon's 'Amelia Bedillia' showed well in the modified class.



Harold & Louis Hartline's Monza is always one of the most original 'from the factory' looking Monza's at the show.



Billy Cannon's '62 'Navy Rampy'.. one of the record breaking seven Rampsides at the event.



Howard Tutt's '66 PG Monza is awarded a top three in the late closed group.



'Ramp-On-It' is back on the road after a one year hiatus. Russ Thuleen rebuilt the turbocharged motor after it suffered a dropped valve seat.



Chris Brown & Molly Bacon have 'Turkle' back on the road after a post convention mishap that left the ultravan 'on the hook' last year. Specialty class award winner two years in a row.



Richard Stolzmann's '65 180 Corsa in the modified late open class top three award.

Vulcan Corvair Enthusiasts

Birmingham, Alabama

Corsa Chapter. 352

32nd Annual Corvair Lovers Holiday The People

Vulcan Corvair once again placed first in the club attendance award with sixteen members.



Danny Joe and Russ are trying to tell Clyde that he is now in Florida.



Ed & Carol Keller, winners of Ladies Choice award



Molly Bacon , Chris Brown and June Bug



Claudia and Howard Tutt enjoying 'The Shrimp Basket'.

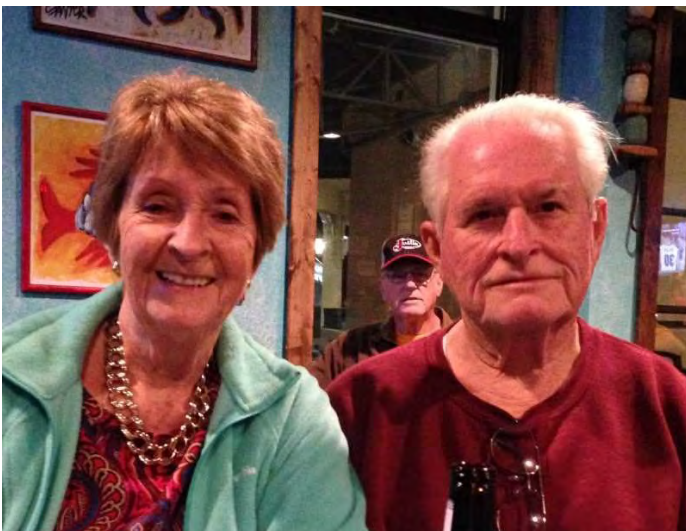

The smiling faces of Louise and Harold Hartline.

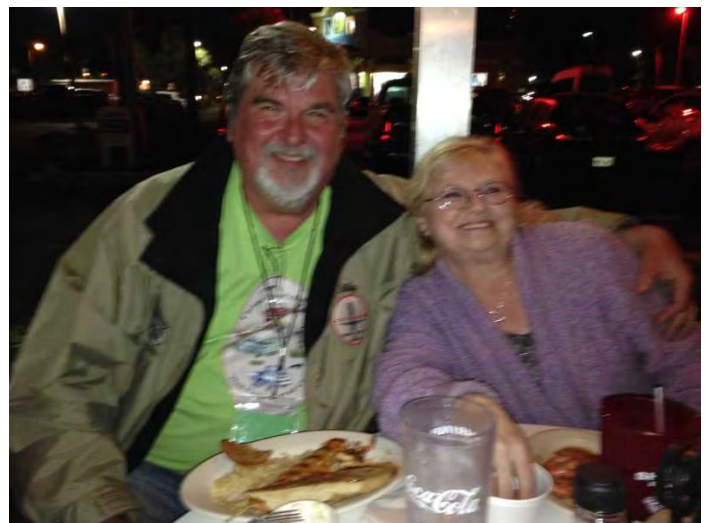

Billy and Judi Cannon.

32nd Annual Corvair Lovers Holiday The People (cont.)

Many thanks to all that contributed pictures this year: Dan Avalone, Richard Stolzmann, Louise Hartline and Judi Cannon.



Russ and Clyde discussing the 140 in Billy's truck..



Saturday night dinner at The Shrimp Basket. A MUCH better option this year.



Second and First Vice Presidents, Billy and Richard.



Howard, Billy, Judi, Russ and Danny prepare for the monthly meeting.



By show of hands, how many have had too much to eat?.



How many can get around a small table for dinner? w/Richard, Russ, Billy 'Uno', Billy 'Quatro', Danny and Ray.



More pictures from the Corvair Lovers Holiday: The Corn Hole Game, Billy showing off the banners to Mary Ann, Lillian wins the Auto Custom Carpets Floor Mats, Many, many Rampys for the public to see, Late Line Up and Judi & Louise in the shade of the Vulcan pop-up shelter.
SEE YOU NEXT YEAR!
But first we go to SPRINGFEST....

THE REVOLUTIONARY
Corvair
 "with the engine in the rear for better handling and stability"
 '60 '61 '62 '63 '64 '65 '66 '67 '68 '69

SPRINGFEST 2017

Celebrating 33 Years of Corvairs in Helen

HOSTED BY

Corvair Atlanta, Heart of Georgia Corvair Club,
Queen City Corvair Club, and Vulcan Corvair Enthusiasts

at

The Festhalle in Helen, Georgia

April 28-29, 2017

To our Corvair friends please pre-register, save money, help us plan and have a chance to win \$35.00

Concours, people's choice, car display, tech session, ladies activities, rally, slow drags, 50/50, raffle for prizes.

Valve cover races (Youth under 14 free)

Hospitality party Friday night

Friday Autocross, test and tune 10:00 a.m. to 12:00 p.m.

1:00 p.m. Autocross (must register for show and pay \$15.00 entry fee)

Car Show and a banquet prepared by our famous cooks on Saturday

Festhalle open at 8:30 a.m. Friday & 7:30 a.m. Saturday

Motel information (Ask for Corvair club rates): available April 27-29

Helendorf River Inn: phone 1-706-878-2271 \$188 (\$238 for riverfront)
for 2 nights (2 nights minimum).

Best Western: 1-706-878-2111, \$69.00 (\$89 for suites) per night
Deluxe continental breakfast included.

Super 8: phone 1-706-878-2191, \$59 per night

Country Inn and Suites: phone 1-706-878-9000, 2 Queen Beds \$99.00

Make reservations by March 30, 2017 to get Corvair rate

Check www.helengeorgialodging.com for other lodging

This year you will be able to pre-order t-shirts. This will assure that you get your shirt even if you are late arriving. We will have some available on site. The men's shirt is antique sapphire and the ladies is hellconia. Pictures will be available on the Springfest website at www.corvairspringfest.com.

Sizes: Men's – Small to 3XL \$15.00 Ladies – Small to 3XL \$15.00

We have planned a Rally this year, please pre-register so that we will have enough packets printed.

Outside spaces are limited, each space will be 2 parking spaces

For those arriving on Thursday, I have reserved a large dining room at Western Sizzler for Thursday night at 6:30 pm.

ATTENTION VCE Members:

Our club responsibilities for SPRINGFEST are for each of our ladies to bring a dessert (Sheet cakes or dessert bars are easier to serve), our men should bring a large bag of original flavor ruffle potato chips.

Event check-in is at the Festhalle.

Information: Lillian Law 1-229-883-4123 or 229-291-0567 lawjandl@aol.com

Autocross information: Billy Cannon 256-404-5998 or 256-839-1905 gtochief@gmail.com

Tentative Schedule of Events

FRIDAY APRIL 28, 2017

Registration	8:30 am - 7:00 pm	Festhalle
Auto-X Set-Up/Car Inspection	8:30am - 10:00 am	City Parking Lot - Large
Auto-X Test and Tune	10:00 am - 12:00 pm	City Parking Lot - Large
Vendors	10:00 am - 6:00 pm	Festhalle
T-shirt Sales and Ticket Sales	10:00 am - 7:00 pm	Festhalle
Car Coral & Car Clean Up	10:00 am - 6:00 pm	Helendorf Parking Lot
Autocross	1:00 pm - until	City Parking Lot - Small
Concours Safety Inspection	2:30 pm - 6:00 pm	Helendorf Parking Lot
Cash Bar	6:00 pm	Festhalle
Hospitality Party	6:30 pm	Festhalle
Valve Cover Races	8:00 pm	Festhalle
50/50 drawing	8:00 pm	Festhalle
Hospitality - After hours	10:00 pm	Upstairs Best Western
Visit Helen Merchants	All Day	

SATURDAY APRIL 29, 2017

Registration	7:30 am - 12:00 pm	Festhalle
Car Clean Up	7:00 am - 9:00 am	Best Western/Helendorf parking lots
Vendors	8:00 am - 5:00 pm	Festhalle & Helendorf
Concours Safety Inspection	8:00 am - 9:00 pm	City Parking Lot - Small
Concours Participants Meeting	9:00 am - 9:15 am	City Parking Lot - Small
Judges Meeting	9:15 am - 9:30 am	City Parking Lot - Small
Concours	9:30 am - 1:30 pm	City Parking Lot - Small
People's Choice	9:30 am - 1:30 pm	City Parking Lot - Large
People's Choice Voting	9:30 am - 12:30 pm	City Parking Lot - Large
Staff & Judges only Lunch	11:30 am - 12:30 pm	Festhalle
Participants Lunch	12:30 pm	Festhalle
<i>Until food is gone \$5.00</i>		
Slow Drags	1:45 pm	City Parking Lot - Large
Rally	2:00 pm	City Parking Lot - Small
Technical Session	2:30 pm - 4:00 pm	Festhalle
Ladies Activity	2:30 pm	Festhalle
Entertainment & Cash Bar	6:00 pm (chips & dip)	Festhalle
Banquet and Awards	7:00 pm -10:00 pm	Festhalle
Hospitality - After hours	10:00 pm	Upstairs Best Western
Car Coral	All day	Helendorf Parking Lot
Visit Helen Merchants	All day	
Door Prizes & 50/50 Drawing	All day	Festhalle
Ticket and T-Shirt Sales	All day	Festhalle



CORVAIRS AT BARBER
 (4th ANNUAL Southeast Corvairs Picnic weekend)
Registration Form
 Hosted by Choo Choo Corvair and Vulcan Corvair Enthusiasts
MAY 26-27, 2017 in Birmingham, Alabama

Name: _____ Spouse: _____
 Address: _____ Phone: _____
 City: _____ State: _____ Zip: _____
 Club Affiliation: _____ Email: _____

You must be registered to take part in any event.

Registration Fees:

\$50 per person or \$100 per Family*/ Friday through Sunday (pre-registered) *Deadline: 15 May 2017* \$ _____
 \$60 per person or \$120 per Family* / Friday through Sunday (On-site) \$ _____
 \$30 per person or \$60 per Family* / Saturday only (On-site registration) \$ _____

* Family = 2 adults and their children under 18

Parade Laps: \$15 per person \$ _____

Total amount enclosed \$ _____

Please make checks payable to Vulcan Corvair

Pre-Order T-Shirt: Mens Size _____ Womens Size _____ *(Options are being considered based on attendance)*

People's Choice Information: (Early means 1960 – 1964, Late means 1965 – 1969)

Vehicle description: Year: _____ Color: _____ Model: _____
 Check all that apply: Early Closed Early Open Late Closed Late Open
 Forward Control 4-Door class (includes Lakewoods) Specialty-modified Ultravan

Registration Includes:

Friday evening hospitality dinner, Saturday picnic lunch and awards dinner. All drinks (water and soft drinks) included. The 3 parade laps around the Barber race track are \$15 per person (every person in the car must pay). A separate charge for the parade laps is shown so uninterested persons will not have to pay for services not wanted. Parade lap participants will also receive a picture of your car at the Barber Motor Sports Park. In the event of a rain out, (every attempt will be made to put the cars on the track) we will include a \$27 guided tour at no additional cost. **Catered banquet dinner (includes choice of 2 meats, 1 vegetable, salad, dessert and drink).** ONE (1) Door prize ticket for each guest will be in your registration packet (see event flyer for additional prizes).

Liability Clause: Entrants and participants by execution of this form release and hold harmless, Choo Choo Corvair Club (Members and Officers), Vulcan Corvair Enthusiasts (Members and Officers) and anyone else connected with the management or presentation of this show, from any and all known damages, injuries, losses, judgments, and/or claims from any causes whatsoever that may be suffered by any entrant or participant to his or her personal property (including family members or friends).

 Signature of Registered Guest

 Signature of Registered Guest

Mail this form to: Vulcan Corvair Enthusiasts, C/O Howard Tutt
 1945 Linden St.
 Leeds, AL 35094



Blast from the Past

Unique Corvair related things that you can find on the internet these days. Greenbrier Camper option a four door early convertible and a cartoon.

CUSTOM CAMPER UNIT

A combination living room, bedroom and kitchen complete with drapes. Can be installed or removed quickly. A gas stove, water jug and cooler are included with the equipment.



PART NO. 985103



"Dear, remember that strange noise whenever I applied the brakes?"





WORLD'S LEADING MANUFACTURER OF

Automotive Replacement Carpet

Nothing makes a bigger impact to the interior of your Corvair like replacing the carpet!

PROUD SPONSORS OF:



Corvairs at *Birmingham ALABAMA*
BARBER
MOTORSPORTS PARK



May 26-27 2017

For details contact Vulcan Corvair @ 256-839-1905 or <mailto:gtochief@gmail.com>

Our 42nd Year!

Get the 2013-2018 Catalog

If you did not get the catalog in 2015 or 2016, you can get one **FREE** on your first **\$50** order during 2017. (Additional catalogs \$3 with an order)

Over 100 new repro parts in the past 3 years.

Clark's Corvair Parts®

400 Mohawk Trail

Shelburne Falls, MA 01370

(413) 625-9776 www.corvair.com

Vulcan Corvair Enthusiasts, a chapter of the Corvair Society of America, is a non-profit club dedicated to the preservation and restoration of the Corvair automobile.

VCE dues of \$20/year pay for a family membership and 12 issues of the Oil Drop Newsletter.



THE OFFICIAL NEWSLETTER OF THE VULCAN CORVAIR ENTHUSIASTS Vol 38, No. 4

In this Issue:

- * AMPHIBIOUS CORVAIR
- * 1977 IECO CORVAIR Handling Package
- * PERFORMANCE CORVAIR Workshop
- * SPRINGFEST 2017
- * CORVAIRS @ Barber Registration
- * CORVAIR CLUB Magazine
- * Classifieds

2017 VCE Officers

President:

John Cleveland
monzaiohn@charter.net
205-834-3120

1st Vice President:

Richard Stolzmann
richey-rich_43@Hotmail.com
205-467-6444

2nd Vice President

(communications):

Billy Cannon
qtochief@gmail.com
C: 256-404-5998
H: 256-839-1905

Secretary:

Steve Daniels
steve_d_daniels@bellsouth.net
C; 205-213-5935
H: 205-995-9474

Treasurer:

Howard Tutt
hftutt@yahoo.com
936-524-7611

VCE Mailing Address

*Vulcan Corvaire Enthusiasts
147 Crossbrook Dr.
Chelsea, Al 35043*

Prez Says:

We had a good meeting on the 17th with a lot of discussion about upcoming events. Springfest is just around the corner with Barber coming up right behind. Our next meeting on April 21 will be a week before Springfest and also the time we need to have everything nailed down for Barber. We need to get door and drawing prizes for both events so it might be a good time to go through those unused gifts you've obtained over the years and give up what's appropriate. Most auto parts stores will donate something and I noticed the other day that Hobby Lobby had some car related home/garage décor items on sale. Also, remember to get some nice things the lady of the house might like. It's looking pretty good for us to get to Springfest this year. I've been able to hold off or reschedule several things at work that have threatened to get in the way. We are confident enough that we've made reservations and registered.

Everyone in the club needs to take a look at their schedule for Barber also. We are going to need all the help we can get to make this a premier event. Billy and his gang have done an incredible job and now it's up to the club to make this come out a true success. If it is at all possible, please plan to attend and help out.

Now for another lessons learned story. If you've ever rebuilt the front suspension on your car, or helped someone do it, you know how big a job it can be. My rebuild was in the winter of 2015, just over two years ago; and now it looks like I get to do most of it again!

The big reason I did a rebuild was the bushings on the car were shot. After picking up a lot of parts from an estate sale I found I had more than enough bushings to do the job, so I would 'save' a bunch of money by using them. Most of the bushings I bought were still sealed in the original packaging from Clark's so they had to be good.... Only problem was that I didn't know how long they had been in that box, in that barn. How many summers they sat in there baking in the heat and humidity.

April 2017

Next Meeting:

Date: Friday, 21 April
Time: 7:00 PM

Place: Fullness Christian Center

Rubber products have a shelf life, the length of which depends on how the rubber is made and what other ingredients are in there, as well as how they are stored. Automobile and equipment bushings, like tires, are made of really strong stuff and they have a definite shelf life. You don't buy tires that are more than five years old. If you do you run the risk of failure way before any warranty expiration. While you may get another tire with the warranty, you may not be alive after the accident.

So here I am, just over two years after a complete front suspension overhaul, getting ready to order new upper and lower A arm bushings for my car and tearing it apart all over again. My lesson learned is that I'll never buy NOS rubber parts again, for any job. The issue is the 'O' part; you don't know how Old the 'O' is!

Remember, the cruise-ins are going to start in full force in April so clean it up, crank it up and get that Vair out there!!!!!!!

John

VCE March Meeting Minutes

Call to Order

Our St. Patrick's Day meeting was called to order at 7:25 PM by President John Cleveland.

Participants

With 15 members and one youth in attendance, a quorum was present.

Financial Report

Treasurer Howard Tutt was unable to attend this evening. He reported by way of Billy Cannon that the finances were the same as last month. Howard has received several pieces of mail addressed to

(Continued on page 2)

VCE Meeting Minutes (cont.)

“Vulcan Corvair” but did not have a count for tonight. Two people are also registering tonight.

Regions Bank lost the changes made to the account after Joe Doughty passed away. Currently, Howard Tutt and Russ Thuleen are signatories on the account. Howard has suggested we move the account to

America’s First which would have no fees unless there were 250 deposits in a month. Check orders would be an additional fee. America’s First requires organizational papers, minutes authorizing the change, and a tax ID number.

There was a discussion of incorporating as a non-profit. Incorporated non-profits must have a tax ID number and file a minimal tax return. Income generated from members (dues, etc.), is not taxable.

Income from outside sources (raffles, sales of merchandise, events, etc.) is taxed. Based on the discussion, the club expressed no interest in incorporating.

There will be a discussion with America’s First if they would extend to the club an account with the same terms using a personal social security number.

Dues for 2017 are now due. To make a payment for dues or to register for Barber, please send your check to our Treasurer:

Howard Tutt
1945 Linden St.
Leeds, AL 35094

Committee Reports

Southeast Corvair Picnic / Corvairs at Barber

At Corvair Lover’s Holiday in Pensacola, the Corvair floor mats being given away at Corvairs at Barber were displayed. Lillian and James Law won the giveaway of a set of floor mats to early registrants.

Pre-registration is going well. The exact count was not available as Howard Tutt is in Texas.

Billy Cannon gave a brief presentation at the Corvair Performance Workshop at the Corvette Museum in Bowling Green, KY. He distributed the presentation for tonight’s attendees to see. It included pictures of t-shirts, cars, the floor mats, and described the event at Barber.

The dinner menu is below:

- Entrée: Pot Roast or Garlic Chicken.
- Vegetables: Garlic Mashed Potatoes, Green Beans, and a Salad.
- Dessert: Banana Pudding
- Drinks: Soft Drinks and Water

There was a discussion of drinks for the event separate from the meal.

These sponsors have been lined up: Huddle House, Advance Auto Parts, Coker Tire, Auto Custom Carpets, IHS Computers, and Fort McClellan Credit Union. Other potential sponsors are being contacted.

The local Fox affiliate wants to cover the event. They will take

pictures and video. In addition, Sam Memmolo has been invited. He mentions Corvairs at Barber on his weekly radio show. The Derby City Club is coming from Louisville, Kentucky. Billy showed several of the items collected to use as giveaways. FYI, the Barber Historics, a vintage event, is the week before Corvairs at Barber. They have asked us to bring Corvairs to display at the event. The Corvairs at Barber banners will be on display for the Historics.

Springfest

There was a discussion of the roles we have at Springfest. The next meeting will focus on Springfest.

Membership

Bill Hadley from Montgomery has joined. Welcome, Bill! He presently has a 1967 Coupe and has been involved in CORSA for many years. Welcome back to Roy Dutton, who rejoined VCE after a hiatus.

Announcements

CORSA has asked what addresses to use for the club. Currently they use Russ Thuleen’s address and Russell Noble’s email. Given the low volume of correspondence, it was decided no changes would be made. Billy Cannon updated the VCE web site on the CORSA site.

Old Business & Tech Session

None

New Business

Please see the Cruise-in section.

Drawings

The \$35 gas money was won by Roy Dutton.

Next Meeting

The next meeting will be Friday, April 21, at Fullness Christian Fellowship.

Adjourn

The meeting was adjourned at 8:12 PM.

Happy Anniversary
Molly & Chris – April 27

Happy Birthday
Teresa McDuffie – April 4
Billy Cannon – April 21

Date	Event	Place
4/28-29/2017	Springfest	Helen, GA
5/26-27/2017	Corvairs at Barber	Barber Motorsports Park & Museum

Send Oil Drop submissions to:

GTOChief@gmail.com

Office: 256-839-1905

Cell: 256-404-5998

NOTE: PLEASE SEND SUBMISSIONS NO LATER THAN THE 25TH OF THE MONTH.

VCE IS on Facebook...Click on the link:
[Vulcan Corvair Enthusiast FB Page](#)

EXPERIMENTAL MILITARY AMPHIBIOUS CHEVY CORVAIR

Posted in *Fourwheeler Magazine* on January 18, 2016

“Well, it seemed like a good idea at the time.”

These words have been spoken by many engineers and executives as people scratched their heads and looked at what had just swallowed up a million bucks of development money. Sometimes those words were spoken by people on the way out the door escorted by security. We don't know if heads rolled after a very odd military prototype debuted from Chevrolet in 1963, but this rig quietly disappeared soon thereafter.

They called it TUFU, an acronym for Truck Utility Floatable Independent. As far as we can tell, it didn't come directly as a result of an Army request; rather it was an idea developed by Chevrolet to sell to the military. It was likely based on certain trends observed by the guys at the commercial and government sales offices at Chevrolet, or perhaps it came from an "unofficial" request. We do know that Jeep built an amphibious prototype at about the same time.



TUFU was designed to be light, compact, and simple. It was rated for a 3/4-ton payload off-highway and 1-ton on the highway. The prototype TUFU sat on an 88-inch wheelbase and could carry six troops in the 23 cubic feet of cargo space, plus the driver and one more up front. The body (or should we say hull) was made of five-ply Royalite, which was one of the earliest successful thermoplastics and was beginning to see use as automotive bodies in the early '60s. It was lighter than fiberglass, structurally stronger, and a more impact resistant. It was easier to mass produce as well, but more expensive.

The heart of TUFU was none other than the air-cooled flat six of the Corvaire. In its industrial form, it made 75 hp and 129 lb-ft from 164 cubic inches. It was mid-mounted, had two one-barrel carbs and used a waterproofed 24V electrical sys-

tem. The spec books aren't clear exactly how the power was transmitted, but they do mention a special aluminum two-speed transaxle/transfer case that incorporated the two ranges and the front differential. An aluminum case Corvaire truck four-speed transmission, with a First gear ratio of 3.65:1, was integrated into the unit. The axle ratios are not listed, nor is the transfer case low-range ratio. The independent suspension used Corvaire diffs and since it's doubtful new ring-and-pinion were produced just for this project, they probably used the lowest ratio offered in the Corvaire: 4.11:1. The spec sheet lists the Corvaire version of the GM Posi limited slip was installed at both ends. Listed tires size was 9.00-16 (non-directional military tread), and those tires worked as paddles in the water, propelling TUFU at a screaming 2.5 mph. On land, top speed was listed at 60 mph.

The Army tested TUFU in 1963. Pictures of the tests exist in a couple of

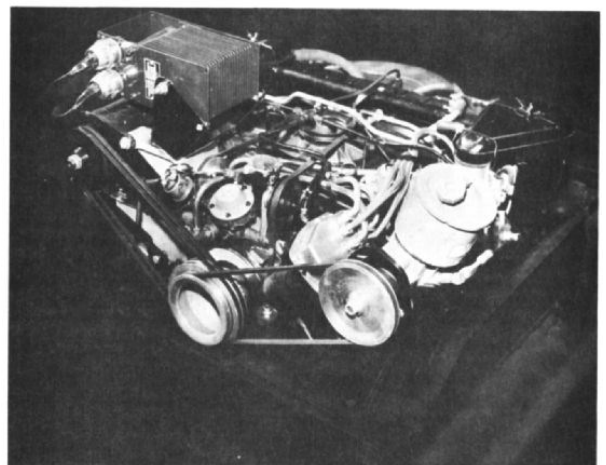

(Continued on page 4)

(Continued from page 3)

books, but we have not seen any test results to report upon. Obviously, TUFU was a no-go and the fate of the single prototype known to have been produced is unknown. The Jeep amphib also disappeared. TUFU is certainly one of those prototypes that makes a guy shrug his shoulders and wonder why. The name is kinda cool though. How ya doing TUFU?

The Details: '63 Chevrolet TUFU

Engine: 164ci Chevrolet air-cooled flat six

Power(hp): 75 @ 3,500 rpm

Torque (lbs-ft): 129 @ 2,600 rpm

Bore & Stroke (in.): 3.44 x 2.94

Comp. Ratio: 8.0:1

Transmission: 4-spd manual
(Saginaw)

Transfer Case: 2-spd, integrated

Front Axle: Independent suspension

Rear Axle: Independent suspension

Tires: 9.00-16 NDT

Wheelbase (in.): 88

L X W x H (in.): 156.5 x 87 x 74

Curb Weight (lbs.): 3,464

GVW: 4,969

Fuel Capacity (gal.): 45

Min, Grd. Clearance (in.): 10.5

App. Angle (deg.): 34

Dep. Angle (deg.): 44

Max Speed (mph): 60

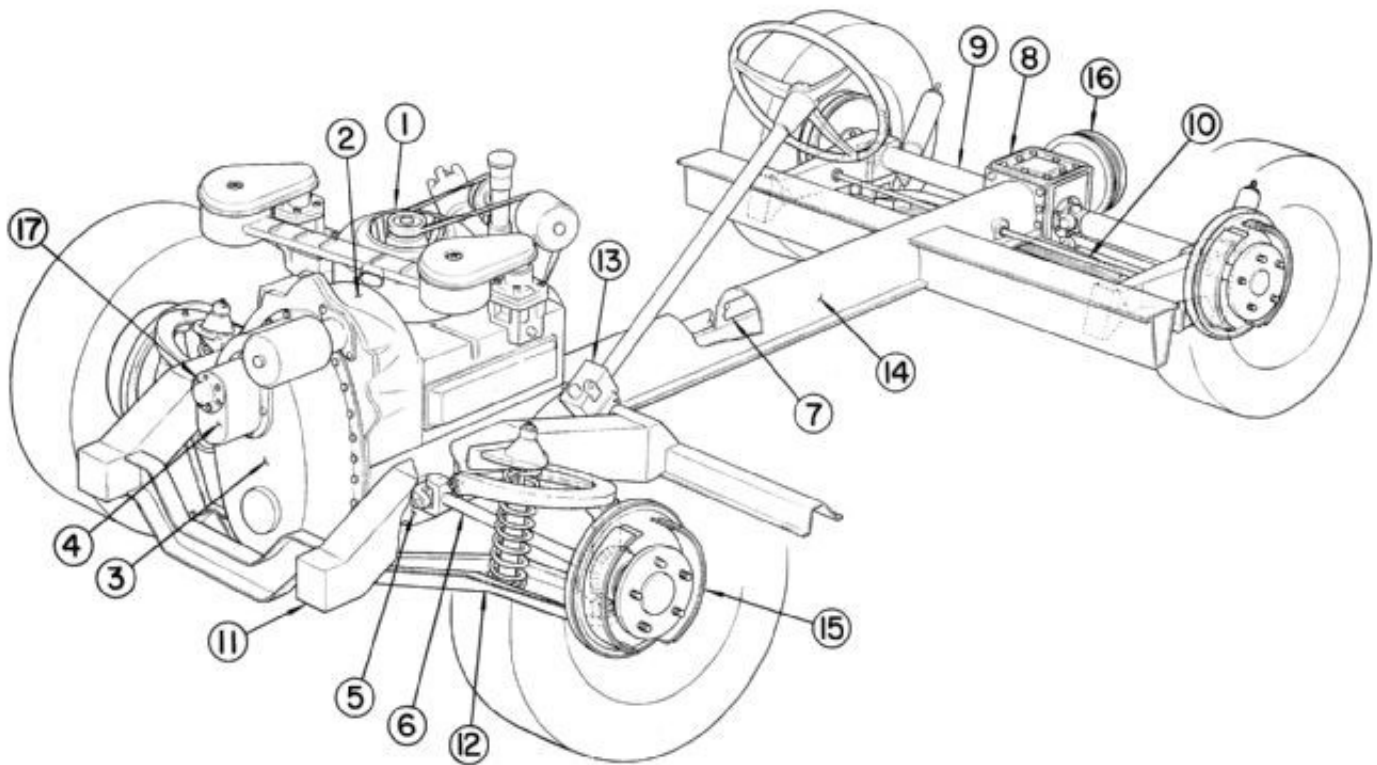
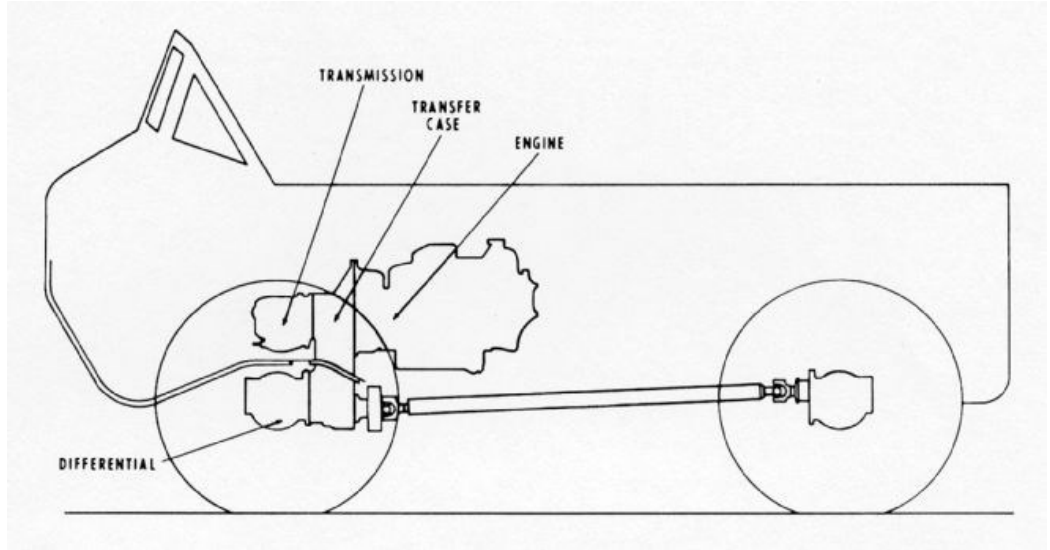

(Continued on page 5)

(Continued from page 4)

The front winch was a Ramsey PTO, probably the same 6,000-pound unit used on military Jeeps of the day, driven off the transmission. The chassis was all aluminum, as were the bumpers and other parts of the framework. The 7-inch brakes had sintered metallic linings so as not to be affected by water, but they were power boosted. The suspension was the same as used with the standard Corvair pickup, but a special spindle in the front incorporated the four-wheel drive. And yeah, look at the Bowtie!

The Royalite used for the body was about 30 percent lighter than the same thickness of fiberglass and could be permanently color impregnated. Impact resistance was much better than aluminum, wood, or fiberglass. Royalite had been around since 1946 and had been improving ever since. The tailgate was waterproofed. The skirts in the wheel openings were found to improve the efficiency of the NDT tires as paddles.

Pretty much a Corvair, but with a huge, double-belted 24V generator and waterproof suppressed ignition. This pic, from the presentation booklet, shows what appears to be a power steering pump. Power steering isn't listed in the specs but seems likely.

The presentation booklet for TUFU from the Chevrolet Engineering Center doesn't show images of the TUFU powertrain, only this line drawing. The transfer case unit was said to be aluminum, as was the transmission housing.

In April 1966, the engineering department at Kaiser Jeep presented a sleek 4x4 prototype that also used a Corvair engine, transmission, and axles in a 4x4 configuration. The layout looks similar but with no powertrain pics of either rig, only drawings, it isn't clear if the GM powertrain was recycled into the Jeep prototype. Certainly, the concept was just about the same.

SUPER-HANDLING PACKAGE

IECO CATALOGUE 1977

This kit will turn your Corvair into a "Porsche beating" Trans-Am car. The competition springs are programmed for firm wheel control. The front anti-roll bar has relocated mounting points that allow it to move freely without binding. Fast steering arms give positive driver control by reducing steering wheel turns to less than three. Re-designed rear-lower control arm bracket forces the rear wheels to move in a parallel manner like a fully independent suspension should. Rear anti-roll bar gives the Corvair a slight high-speed understeer that's desirable for fast cornering. The kit is easy to install and it's furnished with all attaching parts.

The IECO Handling Package Improves the already great handling 1965-69 Corvair. Relocated pivot points for rear-lower control arms, new mounting positions for front roll bar, addition of rear anti-roll bar, and programmed suspension springs all add up to a super Corvair.

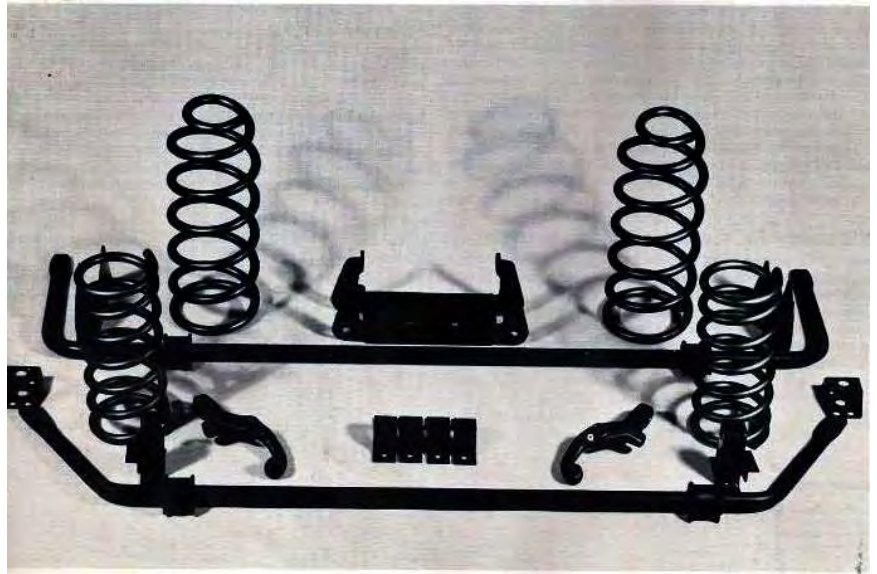

The Handling Package can be purchased as a whole or each part may be bought individually. Make the already great Corvair even greater!

NO. 8-213	SIJPER HANDLING PACKAGE.....	Complete	\$232.70
NO. 8-208	HIGH SPEED STEERING ARMS.....	Pair	\$26.95
NO. 8-212B	COMPETITION SPRINGS—FRONT.....	Pair	\$25.95
NO. 8-212C	COMPETITION SPRINGS—REAR.....	Pair	\$34.95
NO. 8-213A	REAR LOWER CONTROL ARM BRACKET.....		\$28.95
NO. 8-213B	FRONT ANTI-ROLL BAR & PARTS.....		\$58.95
NO. 8-213C	REAR ANTI-ROLL BAR & PARTS.....		\$56.95

THE REVOLUTIONARY

Corvair

"with the engine in the rear for better handling and stability"

'60 '61 '62 '63 '64 '65 '66 '67 '68 '69

2017 PERFORMANCE CORVAIR WORKSHOP



National Corvette Museum (NCM), Bowling Green Kentucky was the site for this year and being only a few hours drive away, Russ Thuleen and I were able to make plans to go after a two year hiatus. Danny Joe drove his Spyder up from Toney, Al and joined us Saturday morning. Russ drove his Turbo Rampside and I rode along as navigator.

Many thanks to Tracy LeVeque, President Performance Corvair Group for arranging the workshop and meeting the challenges of an ever changing schedule of events. Although attendance was down by twenty or so this year, we still had a great time. Location for next year's event will be moved again based on popular vote.

We were looking forward to the planned tour of the Corvette factory next door to the amazing NCM venue that was to be our meeting place. However, after the plant tour was cancelled, Tracy was able to arrange two other tours that were very interesting:



cancelled, Tracy was able to arrange two other tours that were very interesting:

RC Components: This company makes racing wheels for car and motorcycles and they have invited us to tour their plant. This company was formerly featured on the reality show "Orange County Choppers". When on the tour, it was mentioned that it felt like we were watching them make jewelry. Our guide laughed and said, "that's what we call it, jewelry for cars and motorcycles!"

Historic Railpark and Train Museum: This Museum is just a few minutes up the road from the Museum and is located in the beautiful 1925 Train Depot. The guides were excellent story tellers and took us through seven restored cars, including the Locomotive, Presidential Office car, Pullman Dining Car (the Duncan Hines Dining car), a luxury Pullman sleeper, a 1921 Post office Car, a Caboose, a Jim Crow segregation car and a hospital car..

Vulcan Corvair had the ONLY Corvairs at the event (The Rampside and Spyder) so after the scheduled 'Performance Corvair' was a no show, it was decided that the Turbocharged Rampside should take the place of honor in the middle of NCM's Convention Hall! I asked Russ how it felt to



'Ramp-On-It' is opened for all to see. 150 hp turbocharged engine, gas heater, air conditioning, 'Idiitit' steering column, and many other custom touches.



have the only Corvair Rampside inside the museum and he informed me that his was the second, James Law's 1961 Rampy already had that honor. Still...quite the honor and I was proud to have acted as 'ground guide' for Russ as he drove the

red and black truck through the vehicle entry door of the convention hall.

Of course we were offered free reign of the museum and I will admit it is an awesome place but the area of the 'sinkhole' was the most interesting because of the unfortunate event and how it now enshrines the historic 'vettes that were damaged. "Some tears

were shed," is how Museum Executive Director Wendell Strode described the news of eight Corvettes falling victim to the sinkhole. There is a panel that provides photos, videos and facts on each of the cars, as well as an interactive "before" model of each Corvette. An illuminated acrylic case illustrates precisely where each car fell into the hole. The recovery of the Corvettes from the sinkhole was no easy task! While you can see short video clips and photos of the process within the Cars Affected section, you can get behind the controls of a crane at NCM's interactive game within "The Recovery." Guests of all ages will enjoy digitally recovering all eight cars and putting them safely in their garage bays.



The NCM made international news headlines on February 12, 2014 when a sinkhole collapsed in the Skydome of the Museum in the wee hours of the morning. Thankfully, no one was in the building when it happened.

Vulcan Corvair Enthusiasts

Birmingham, Alabama

Corsa Chapter. 352

SPRINGFEST 2017

Celebrating 33 Years of Corvairs in Helen

HOSTED BY

Corvair Atlanta, Heart of Georgia Corvair Club,
Queen City Corvair Club, and Vulcan Corvair Enthusiasts

at

The Festhalle in Helen, Georgia

April 28-29, 2017

To our Corvair friends please pre-register, save money, help us plan and have a chance to win \$35.00

Concours, people's choice, car display, tech session, ladies activities, rally, slow drags, 50/50, raffle for prizes.

Valve cover races (Youth under 14 free)

Hospitality party Friday night

Friday Autocross, test and tune 10:00 a.m. to 12:00 p.m.

1:00 p.m. Autocross (must register for show and pay \$15.00 entry fee)

Car Show and a banquet prepared by our famous cooks on Saturday

Festhalle open at 8:30 a.m. Friday & 7:30 a.m. Saturday

Motel information (Ask for Corvair club rates): available April 27-29

Helendorf River Inn: phone 1-706-878-2271 \$188 (\$238 for riverfront)
for 2 nights (2 nights minimum).

Best Western: 1-706-878-2111, \$69.00 (\$89 for suites) per night
Deluxe continental breakfast included.

Super 8: phone 1-706-878-2191, \$59 per night

Country Inn and Suites: phone 1-706-878-9000, 2 Queen Beds \$99.00

Make reservations by March 30, 2017 to get Corvair rate

Check www.helengeorgialodging.com for other lodging

This year you will be able to pre-order t-shirts. This will assure that you get your shirt even if you are late arriving. We will have some available on site. The men's shirt is antique sapphire and the ladies is hellconia. Pictures will be available on the Springfest website at www.corvairspringfest.com.

Sizes: Men's – Small to 3XL \$15.00 Ladies – Small to 3XL \$15.00

We have planned a Rally this year, please pre-register so that we will have enough packets printed.

Outside spaces are limited, each space will be 2 parking spaces

For those arriving on Thursday, I have reserved a large dining room at Western Sizzler for Thursday night at 6:30 pm.

ATTENTION VCE Members:

Our club responsibilities for SPRINGFEST are for each of our ladies to bring a dessert (Sheet cakes or dessert bars are easier to serve), our men should bring a large bag of original flavor ruffle potato chips.

Event check-in is at the Festhalle.

Information: Lillian Law 1-229-883-4123 or 229-291-0567 lawjandl@aol.com

Autocross information: Billy Cannon 256-404-5998 or 256-839-1905 gtochief@gmail.com

Tentative Schedule of Events

FRIDAY APRIL 28, 2017

Registration	8:30 am - 7:00 pm	Festhalle
Auto-X Set-Up/Car Inspection	8:30am - 10:00 am	City Parking Lot - Large
Auto-X Test and Tune	10:00 am - 12:00 pm	City Parking Lot - Large
Vendors	10:00 am - 6:00 pm	Festhalle
T-shirt Sales and Ticket Sales	10:00 am - 7:00 pm	Festhalle
Car Coral & Car Clean Up	10:00 am - 6:00 pm	Helendorf Parking Lot
Autocross	1:00 pm - until	City Parking Lot - Small
Concours Safety Inspection	2:30 pm - 6:00 pm	Helendorf Parking Lot
Cash Bar	6:00 pm	Festhalle
Hospitality Party	6:30 pm	Festhalle
Valve Cover Races	8:00 pm	Festhalle
50/50 drawing	8:00 pm	Festhalle
Hospitality - After hours	10:00 pm	Upstairs Best Western
Visit Helen Merchants	All Day	

SATURDAY APRIL 29, 2017

Registration	7:30 am - 12:00 pm	Festhalle
Car Clean Up	7:00 am - 9:00 am	Best Western/Helendorf parking lots
Vendors	8:00 am - 5:00 pm	Festhalle & Helendorf
Concours Safety Inspection	8:00 am - 9:00 pm	City Parking Lot - Small
Concours Participants Meeting	9:00 am - 9:15 am	City Parking Lot - Small
Judges Meeting	9:15 am - 9:30 am	City Parking Lot - Small
Concours	9:30 am - 1:30 pm	City Parking Lot - Small
People's Choice	9:30 am - 1:30 pm	City Parking Lot - Large
People's Choice Voting	9:30 am - 12:30 pm	City Parking Lot - Large
Staff & Judges only Lunch	11:30 am - 12:30 pm	Festhalle
Participants Lunch	12:30 pm	Festhalle
<i>Until food is gone \$5.00</i>		
Slow Drags	1:45 pm	City Parking Lot - Large
Rally	2:00 pm	City Parking Lot - Small
Technical Session	2:30 pm - 4:00 pm	Festhalle
Ladies Activity	2:30 pm	Festhalle
Entertainment & Cash Bar	6:00 pm (chips & dip)	Festhalle
Banquet and Awards	7:00 pm -10:00 pm	Festhalle
Hospitality - After hours	10:00 pm	Upstairs Best Western
Car Coral	All day	Helendorf Parking Lot
Visit Helen Merchants	All day	
Door Prizes & 50/50 Drawing	All day	Festhalle
Ticket and T-Shirt Sales	All day	Festhalle



CORVAIRS AT BARBER
 (4th ANNUAL Southeast Corvairs Picnic weekend)
Registration Form
 Hosted by Choo Choo Corvair and Vulcan Corvair Enthusiasts
MAY 26-27, 2017 in Birmingham, Alabama

Name: _____ Spouse: _____
 Address: _____ Phone: _____
 City: _____ State: _____ Zip: _____
 Club Affiliation: _____ Email: _____

You must be registered to take part in any event.

Registration Fees:

\$50 per person or \$100 per Family*/ Friday through Sunday (pre-registered) *Deadline: 15 May 2017* \$ _____
 \$60 per person or \$120 per Family* / Friday through Sunday (On-site) \$ _____
 \$30 per person or \$60 per Family* / Saturday only (On-site registration) \$ _____

* Family = 2 adults and their children under 18

Parade Laps: \$15 per person \$ _____

Total amount enclosed \$ _____

Please make checks payable to Vulcan Corvair

Pre-Order T-Shirt: Mens Size _____ Womens Size _____ (Options are being considered based on attendance)

People's Choice Information: (Early means 1960 – 1964, Late means 1965 – 1969)

Vehicle description: Year: _____ Color: _____ Model: _____
 Check all that apply: Early Closed Early Open Late Closed Late Open
 Forward Control 4-Door class (includes Lakewoods) Specialty-modified Ultravan

Registration Includes:

Friday evening hospitality dinner, Saturday picnic lunch and awards dinner. All drinks (water and soft drinks) included. The 3 parade laps around the Barber race track are \$15 per person (every person in the car must pay). A separate charge for the parade laps is shown so uninterested persons will not have to pay for services not wanted. Parade lap participants will also receive a picture of your car at the Barber Motor Sports Park. In the event of a rain out, (every attempt will be made to put the cars on the track) we will include a \$27 guided tour at no additional cost. **Catered banquet dinner (includes choice of 2 meats, 1 vegetable, salad, dessert and drink).** ONE (1) Door prize ticket for each guest will be in your registration packet (see event flyer for additional prizes).

Liability Clause: Entrants and participants by execution of this form release and hold harmless, Choo Choo Corvair Club (Members and Officers), Vulcan Corvair Enthusiasts (Members and Officers) and anyone else connected with the management or presentation of this show, from any and all known damages, injuries, losses, judgments, and/or claims from any causes whatsoever that may be suffered by any entrant or participant to his or her personal property (including family members or friends).

 Signature of Registered Guest

 Signature of Registered Guest

Mail this form to: Vulcan Corvair Enthusiasts, C/O Howard Tutt
 1945 Linden St.
 Leeds, AL 35094



GIGANTIC BODY & ACCESSORIES GUIDE!



CORVAIR CLUB MAGAZINE

SPECIALTY TOOLS

FC's—THE NEW NORM?

**PLUS: POWER UPGRADES MADE EASY
MAKE YOUR CORVAIR FASTER**



CORVAIR OF THE MONTH



**SEE INSIDE:
CORVAIRS
@ BARBER MOTOR-
SPORTS PARK
MAY 26-27, 2017**



\$3.95 US 4.95 Canada





WORLD'S LEADING MANUFACTURER OF

Automotive Replacement Carpet

Nothing makes a bigger impact to the interior of your Corvair like replacing the carpet!

PROUD SPONSORS OF:



Corvairs at *Birmingham ALABAMA*
BARBER
MOTORSPORTS PARK



May 26-27 2017

For details contact Vulcan Corvair @ 256-839-1905 or <mailto:gtochief@gmail.com>

Our 42nd Year!

Get the 2013-2018 Catalog

If you did not get the catalog in 2015 or 2016, you can get one **FREE** on your first **\$50** order during 2017. (Additional catalogs \$3 with an order)

Over 100 new repro parts in the past 3 years.

Clark's Corvair Parts®

400 Mohawk Trail

Shelburne Falls, MA 01370

(413) 625-9776 www.corvair.com

Vulcan Corvair Enthusiasts, a chapter of the Corvair Society of America, is a non-profit club dedicated to the preservation and restoration of the Corvair automobile.

VCE dues of \$20/year pay for a family membership and 12 issues of the Oil Drop Newsletter.



THE OFFICIAL NEWSLETTER OF THE VULCAN CORVAIR ENTHUSIASTS Vol 39, No. 5

In this Issue:

- * **SPRINGFEST STATISTICS & RESULTS**
- * **VULCANS AT SPRINGFEST**
- * **This Is Not My Truck**
- * **NOBLE Car Show**
- * **Shelby Career Center and School**
- * **CORVAIRS @ Barber Registration**
- * **Classifieds**

2017 VCE Officers

President:

John Cleveland
monzaiohn@charter.net
 205-834-3120

1st Vice President:

Richard Stolzmann
richey-rich_43@Hotmail.com
 205-467-6444

2nd Vice President (communications):

Billy Cannon
qtochief@gmail.com
 C: 256-404-5998
 H: 256-839-1905

Secretary:

Steve Daniels
steve_d_daniels@bellsouth.net
 C; 205-213-5935
 H: 205-995-9474

Treasurer:

Howard Tutt
hftutt@yahoo.com
 936-524-7611

VCE Mailing Address

*Vulcan Corvair Enthusiasts
 147 Crossbrook Dr.
 Chelsea, Al 35043*

From the Prez:

What a great weekend in Helen, GA.!

Springfest 2017 is now in the history books and it will go down in my book as one of the best. It rained most of the way up on Thursday but the weather cleared and the temps stayed pretty mild. It was a record crowd and lots of fine Vairs. Mine was there too.



Tried my hand at Concourse judging this year. Watched the safety check on Friday afternoon and participated in the inspections on Saturday. Had a seasoned judge to show me the ropes as we did trunks and engine compartments. There were only 6 cars so it didn't take very long. Several judges made sure I was aware that newbies usually get the undercarriage. I volunteered, but not too loud so nobody would hear me.

Now it is time to prepare for Barber. Please be at the meeting on May 19 so we can hammer out the remainder of the details. Billy and his crew have done an excellent job and now it's up to us, the members, to help them make this a premier event for 2017 and beyond.

We had some good registration numbers at Helen which, when the remainder of the members (me included) register, should give us a good crowd. I haven't been to Barber but everyone I talk to that has been there says it is something you will always remember; it is a class act. If at all possible make plans to go.

This weekend will be my do over front suspension overhaul. I want to have the car driving nice (read safely) so I can get it on the track. With little or no front bushings it is a little loosy goosy. New bushings and a rebuilt steering box should take care of that. See you at the meeting on the 19th.

Remember, the cruise-ins and car shows are up in full force so clean it up, crank it up and get that Vair out there!!!!!!!!!!

May 2017

Next Meeting:

Date: Friday, 19 May

Time: 7:00 PM

Place: Fullness Christian Center

VCE April Meeting Minutes

Call to Order

The meeting was called to order at 7:34 PM by President John Cleveland.

Participants

With 17 members in attendance, a quorum was present.

Minutes of the previous Meeting

Minutes of the March meeting were published in The Oil Drop. Copies were distributed and reviewed by the membership before the meeting started. A motion was made, seconded, and passed to approve the minutes as presented in The Oil Drop.

Financial Report

Rent for the quarter has been paid. We have 27 paid members as of tonight. Six members are unpaid. John Cleveland and Howard Tutt re-executed the papers that Regions Bank had lost.

Dues for 2017 are now due. To make a payment for dues or to register for Barber, please send your check to our Treasurer:

Howard Tutt
 1945 Linden St.
 Leeds, AL 35094

Committee Reports

Springfest

Our members are responsible for desserts preferably a sheet cake), original Ruffles, and 24 cans of name-brand non-diet sodas per male member. People who cannot go are to contribute as well. It was decided Billy would purchase on behalf of those who could not go to Springfest and solicit reimbursements if needed. Several members donated cash tonight toward our contributions of food.

(Continued on page 2)

VCE Meeting Minutes (cont.)

Sixteen members are going to Helen. For those going, we will meet Thursday at 8AM at the Hardees at Exit 199 in Heflin, AL, on I-20.

Corvairs at Barber

We're taking the banners to Helen and will solicit registrations at Springfest for Corvairs at Barber.

Howard Tutt presented a budget report to those in attendance. Almost everyone in the club is going. Members are to pay for registration. We're roughly 19 registrations shy of breaking even at this point, which is good. The reason the number of registrations needed being higher than the current deficit would suggested is because there are variable costs associated with each registration.

Members with vans will shuttle ladies who wish to participate in the shopping excursion Saturday.

The ad for Barber will run in the CORSA Communique through May. CORSA has not invoiced ACC for the ad. If ACC does not get billed for the CORSA ad, ACC will pay VCE what would have been the ad fee.

The camera crew from the local FOX TV affiliate has committed to filming portions of the event.

The museum tour is not included in the fee, but we do get a discounted rate for the guided tour.

Membership

Howard read a nice letter from Joe and Carol Popinski complimenting the club and making a donation. He has a Corvair he's been "working on for years."

A group went to see the 8-door in TN and they were unable to make a deal. The person in TN also said he owned the "Claymobile" which was reportedly owned by Cassius Clay/Mohammed Ali.

Billy Cannon celebrates his (we won't say which one) birthday today. Congratulations! We extend prayers and best wishes to Clyde Cork who is having a stent installed.

Old Business

None

New Business

The Veterans Day Parade in Birmingham has requested Vulcan Corvair participate en masse. Governor Kay Ivey will be riding in a Corvair at the parade.

Drawings

The \$34 gas money was won by Danny Robertson.

Next Meeting

The next meeting will be Friday, May 19, at Fullness Christian Fellowship.

Adjourn

The meeting was adjourned at 8:27 PM.

SPRINGFEST STATISTICS

Submitted by Lillian Law

199 Registrations with 6 no shows, more than 300 name badges were made.

35 clubs were represented from 15 states.

David Clamp counted 106 Corvairs on the show fields and swap meet areas, some were still parked at the Hotels.

31 cars participated in the Rally with 2 to 6 people in the cars.

Old Corvair friends and new Corvair friends enjoyed great fellowship. Attendants agreed that the Corvairs were the nicest they had seen at Helen in a long time. The weather was perfect after the rain cleared out on Thursday, anyway it did not rain on the show.

We had a record number of vendors inside and out.

Don Marlowe and Judi Cannon each went home with a set of tires. There were many other nice door prizes.

Brenda Cork and Eleanor Bruce won 50/50 drawings.

If you missed watching the Youth Valve Cover Races you missed a treat. They really get into the spirit of the race. Donnie even let some of them man the mic.

The Early Registration Drawing went to John Mar from Sammamish, Washington. This was his second Springfest.



Thanks to the host clubs and many volunteers and God for the beautiful weather "Springfest 2017"

Happy Birthday

Sherrri Daniels – May 22

Molly Bacon – May 29

Date	Event	Place
5/26-27/2017	Corvairs at Barber	Barber Motorsports Park & Museum

Send Oil Drop submissions to:

GTOChief@gmail.com

Office: 256-839-1905

Cell: 256-404-5998

NOTE: PLEASE SEND SUBMISSIONS NO LATER THAN THE 25TH OF THE MONTH.

VCE IS on Facebook...Click on the link:

[Vulcan Corvair Enthusiast FB Page](#)

Vulcan Corvair Enthusiasts



Birmingham, Alabama

Corsa Chapter. 352



CORSA is now on [Facebook](#)



This Is Not My Truck



I wanted to drive my car.
I gave it a good effort.
Lots of new parts, lots of time, tons of work.
But something in the engine went sideways.
So I drove this truck.

This is not my truck.
I didn't build this truck, I didn't paint this truck.
I didn't pick out the wheels, or buy the tires.
I didn't convert it from auto to manual.
I haven't drilled any holes in this truck.
But I've been around it for a while now.

This has been my dad's truck since 1979.
He built it. My uncle painted it.
And today, I got to drive it.
I have *GOT* to get me one of these.

"Life is a story. Live a good one."

Phil Hartline
April 2017



NOBLE PARK CAR SHOW

PROUDLY MADE  IN THE USA

This show was a benefit put on by The Westview Relay for Life Cruise-In and was a successful fundraiser that brought five Vulcan Corvairs from near and far, including Danny Robertson from Huntsville, Russ Thuleen from Chelsea, Howard Tutt from Leeds and locals Billy & Judi Cannon. Thanks to all who participated! This show is where we picked up two more sponsors for the Barber event: Sky Depth Aerial Photography and Black Sheep Customs.

**Westview Baptist Church
"Cruise-In"
Proceeds for Relay for Life** 

Classic/New Cars & Trucks, Hot Rods & Motorcycles

**Saturday, April 8, 2017
10:00am-2:00pm** 

**Noble Park-Sylacauga
(Across from Jack's on Hwy 21)**

50-50 Jackpot   **No Entry Fee!**

Hot Dogs, Chips & Drinks  

Contact Harley at 256-487-1410
See back for map or visit www.wherethefriendsbecomefamily.com



2017 SPRINGFEST REPORT

The www.corvairspringfest.com site has been updated with the 2017 results and photos.

“SPRINGFEST 2017 “ RESULTS

CONCOURS WINNERS:

<u>BEST OF SHOW:</u>		SCORE:
Jim Morgan	65 Maroon Corsa Convertible	94.625
<u>GOLD:</u>		
Jim Morgan	65 Maroon Corsa Convertible	94.625
<u>SILVER:</u>		
Mike Garoust	64 Green Greenbrier	92.875
Larry Woodfin	66 Green Corsa Convertible	91.125
Phil Domser	64 Red Spyder Coupe	90.3
<u>BRONZE:</u>		
Don Cook	65 Red Monza Convertible	84.

PEOPLE’S CHOICE:

EARLY OPEN:

1st Place:	Randy Hall	64 Red	Spyder
2nd Place	Al Rich	64 Maroon	Monza
3rd Place	Don Richards	64 Blue	Monza
4th Place	Richard Sande	64 Yellow	Monza

EARLY CLOSED:

1st Place	Paula Hilderbrand	64 Red	Monza
2nd Place	Chris Condrey	64 Red	Spyder
3rd Place	Gary Greenwood	64 Yellow	Monza
4th Place	Steve Lambert	64 Aqua	Monza

LATE OPEN:

1st Place	Mike Gassmann	65 Green	Monza
2nd Place	David Clamp	65 Danube Blue	Corsa
3rd Place	Mike Baldwin	66 White	Monza
3rd Place	Jeff Murrell	68 Ash Gold	Monza
3rd Place	Jim Guider	65 Evening Orchid	Monza
4th Place	Linda & Mark Allen	65 Convertible	Monza

LATE CLOSED:

1st Place	Ben Carey	65 Black	Corsa
2nd Place	Cecil Tripplett	69 Orange	Monza
2nd Place	Van Neal	65 Turquoise	Monza
3rd Place	Mikey Birkinbine	67 Red	500 Coupe
4th Place	Ronald Gizzi	65 Blue	Monza

FOUR DOOR:

1ST Place	Dante Bernardini	64 Red/White	Monza
2nd Place	Joe Manus	61 Blue	500
3rd Place	Shirley Smith	67 Blue	Monza
4th Place	Jamesie Neyman	66 Blue	Monza

LAKWOODS:

1st Place	Sandra McClintock	61 Blue
2nd Place	Jewell DeYoung	62 Blue
3rd Place	Keith Henline	61 Teal/White

FORWARD CONTROL:

1ST Place	Jerry Wells	63 Gold/Beige	Rampside
2nd Place	Dee Charest	64 Green	Rampside
3rd Place	Dean Gemberling	63 Yellow	Rampside
4th Place	Duane Sipes	61 Red	Rampside

SPECIALTY:

1st Place	David Drolet	65 Black	Monza
2nd Place	Chris Wiley	66 White	Corsa
3rd Place	James Cheek	63 Silver	Sprint
4th Place	Chris Law	64 Black/Gold	Trike

ULTRA VAN:

1st Place	Chris Brown	68 Bronze/White
-----------	-------------	-----------------

VALVE COVER RACES:

ADULTS:

1st Place	Mke Callahan
2nd Place	Gary Greenwood, Sr.
3rd Place	James Cheek

YOUNG RACERS:

1st Place	“Lightning Lincoln”	Lincoln Haddad
2nd Place	“Coyote 53”	Aiden Tetro
3rd Place	“Zany Zane”	Zane Cheek

PARTICIPANTS:

Hudson Haddad
Pierce Haddad
Mikey Birkinbine
Grant Philips
“Wild Flower” Tetro

AUTO CROSS:

1st Place Ladies	Patti Jenkins	37.76	64 Convertible
1st Place Early	Gary Greenwood, Sr.	35.13	64 Coupe
1st Place Late	Don Marlowe	32.49	66 Monza Coupe
1st Specialty	Eddie Meadows	32.48	60 Dixie T
Fastest Time	Tony Ellison	31.92	65 Monza Convertible

AUTO CROSS CONTINUED:

Chandler Bishop	32.69	65 Monza
Billy Bruce	36.24	65 Corsa
James Cheek	36.67	63 Sprint
Jamie Cheek	40.06	66 Monza Convertible
Raymond Paul	33.00	65 Monza Convertible
Bill Prichard	33.87	65 Amanti Kit Car
Ronnie Jenkins	35.17	64 Monza Convertible
Richard Williams	36.20	69 Monza Coupe
Chris Wiley	34.42	66 Corsa
Mark Allen	36.99	65 Conv.
Mike Gassmann	33.49	65 Corsa



The Shelby County
**College and Career Center's
Car, Truck, and Motorcycle
Show**

ANTIQUE & LATE MODEL VEHICLES

Our 7th Annual Car Show will be the event of the year for the Entire FAMILY. Show is FREE to the public. There will be a Large Variety of Vehicles, Oldies Music, Contestant Door Prizes and Many Unique Trophies!

Entrance Fees:

Cars and Trucks: \$15.00

Motorcycles: \$10.00

Saturday, May 20, 2017

9:00 am – 1:00 pm

(Gates open for contestants at 7:00 am/Awards 12:30)

At the Shelby County College and Career Center
701 Hwy 70, Columbiana, AL 35051
For More Information call 205-682-6587

Look us up on Facebook @ Shelby County College and Career Center Annual Car Show.
All proceeds benefit our students in the Collision Repair, Automotive Technology, and Culinary department directly.

Vulcan Corvair Enthusiasts



Birmingham, Alabama

Corsa Chapter. 352

CORVAIRS AT BARBER
 (4th ANNUAL Southeast Corvairs Picnic weekend)
Registration Form
 Hosted by Choo Choo Corvair and Vulcan Corvair Enthusiasts
MAY 26-27, 2017 in Birmingham, Alabama

Name: _____ Spouse: _____
 Address: _____ Phone: _____
 City: _____ State: _____ Zip: _____
 Club Affiliation: _____ Email: _____

You must be registered to take part in any event.

Registration Fees:

\$50 per person or \$100 per Family*/ Friday through Sunday (pre-registered) *Deadline: 15 May 2017* \$ _____
 \$60 per person or \$120 per Family* / Friday through Sunday (On-site) \$ _____
 \$30 per person or \$60 per Family* / Saturday only (On-site registration) \$ _____

* Family = 2 adults and their children under 18

Parade Laps: \$15 per person \$ _____

Total amount enclosed \$ _____

Please make checks payable to Vulcan Corvair

Pre-Order T-Shirt: Mens Size _____ Womens Size _____ *(Options are being considered based on attendance)*

People's Choice Information: (Early means 1960 – 1964, Late means 1965 – 1969)

Vehicle description: Year: _____ Color: _____ Model: _____
 Check all that apply: Early Closed Early Open Late Closed Late Open
 Forward Control 4-Door class (includes Lakewoods) Specialty-modified Ultravan

Registration Includes:

Friday evening hospitality dinner, Saturday picnic lunch and awards dinner. All drinks (water and soft drinks) included. The 3 parade laps around the Barber race track are \$15 per person (every person in the car must pay). A separate charge for the parade laps is shown so uninterested persons will not have to pay for services not wanted. Parade lap participants will also receive a picture of your car at the Barber Motor Sports Park. In the event of a rain out, (every attempt will be made to put the cars on the track) we will include a \$27 guided tour at no additional cost. **Catered banquet dinner (includes choice of 2 meats, 1 vegetable, salad, dessert and drink).** ONE (1) Door prize ticket for each guest will be in your registration packet (see event flyer for additional prizes).

Liability Clause: Entrants and participants by execution of this form release and hold harmless, Choo Choo Corvair Club (Members and Officers), Vulcan Corvair Enthusiasts (Members and Officers) and anyone else connected with the management or presentation of this show, from any and all known damages, injuries, losses, judgments, and/or claims from any causes whatsoever that may be suffered by any entrant or participant to his or her personal property (including family members or friends).

 Signature of Registered Guest

 Signature of Registered Guest

Mail this form to: Vulcan Corvair Enthusiasts, C/O Howard Tutt
 1945 Linden St.
 Leeds, AL 35094



CLASSIFIEDS

1961 Corvair 47,000 actual miles. Engine has been disassembled to replace all gaskets and seals. Body-VG. No rust-outs. Interior-VG. Includes 2 complete parts cars and many NEW and USED parts. \$1,000. Talladega, AL (205) 266-7675

Russ and I dropped by and talked with William and took these pictures back in late 2015. He asked that I repost. If they don't sell at this price he is going to SCRAP them! He has the p'work to prove the mileage on this car. A unique example...the original owner only wanted ONE option and she chose the PG.



William Browning
Talladega, AL (205) 266-7675 Email: corvair700@cloud.com



WORLD'S LEADING MANUFACTURER OF

Automotive Replacement Carpet

Nothing makes a bigger impact to the interior of your Corvair like replacing the carpet!

PROUD SPONSORS OF:



Corvairs at *Birmingham ALABAMA*
BARBER
MOTORSPORTS PARK



May 26-27 2017

For details contact Vulcan Corvair @ 256-839-1905 or <mailto:gtochief@gmail.com>

Our 42nd Year!

Get the 2013-2018 Catalog

If you did not get the catalog in 2015 or 2016, you can get one **FREE** on your first **\$50** order during 2017. (Additional catalogs \$3 with an order)

Over 100 new repro parts in the past 3 years.

Clark's Corvair Parts®

400 Mohawk Trail

Shelburne Falls, MA 01370

(413) 625-9776 www.corvair.com

Vulcan Corvair Enthusiasts, a chapter of the Corvair Society of America, is a non-profit club dedicated to the preservation and restoration of the Corvair automobile.

VCE dues of \$20/year pay for a family membership and 12 issues of the Oil Drop Newsletter.



THE OFFICIAL NEWSLETTER OF THE VULCAN CORVAIR ENTHUSIASTS Vol 39, No. 6

SPECIAL EDITION

Corvairs

at BARBER

2017 VCE Officers

President:

John Cleveland
monzaiohn@charter.net
 205-834-3120

1st Vice President:

Richard Stolzmann
richey-rich_43@hotmail.com
 205-467-6444

2nd Vice President (communications):

Billy Cannon
qtochief@gmail.com
 C: 256-404-5998
 H: 256-839-1905

Secretary:

Steve Daniels
steve_d_daniels@bellsouth.net
 C: 205-213-5935
 H: 205-995-9474

Treasurer:

Howard Tutt
hftutt@yahoo.com
 936-524-7611

VCE Mailing Address

Vulcan Corvair Enthusiasts
 147 Crossbrook Dr.
 Chelsea, AL 35043



From the Prez:

Thanks to Billy and his crew for a great weekend car show! Their hard work and dedication to putting this event on showed through at every turn. For those of you who missed it, I don't know what to say. Good food, great company and a trip to Barber plus laps.

Words cannot describe the Barber museum. From the time you turn the corner to drive in until you walk in the door you know you are in for something special. And you are. I've had several people describe the museum and grounds to me and all the descriptions rang true. The grounds are beautiful and the museum is an almost overwhelming visual experience. From the back of the museum you have an excellent view of the track and can watch while drivers are practicing.

An added bonus for me was meeting the guy who was in line to buy my convertible ten years ago. He just happened to be at the museum when we drove in and spotted my car in the bunch. From the Chicago area, he had seen the car advertised for sale and had come down to McCalla, AL to look at it. When I looked at it the owner told me there was someone who was going to buy it and if I wanted it to make an offer fast. I came back the next day with a wad of bills and the deal was done. Things like that just don't happen every day. While we didn't have much time

June 2017

Next Meeting:

Date: Friday, 16 June

Time: 7:00 PM

Place: Fullness Christian Center

to talk, I came away with a little more history about my car and a new friend. It doesn't get much better than that.

If you didn't get a chance to attend this year, you may want to pencil in the date on your calendar for next year. I'm sure you won't be disappointed. Check our Facebook page for the pics and you'll see why.

Remember, the cruise-ins and car shows are up in full force so clean it up, crank it up and get that Vair out there!!!!!!!

John

VCE May Meeting Minutes

Call to Order

The meeting was called to order at 7:29 PM by President John Cleveland.

Participants

With 17 members in attendance, a quorum was present.

Minutes of the previous Meeting

Minutes of the April meeting were published in The Oil Drop. Copies were distributed and reviewed by the membership before the meeting started. A motion was made, seconded, and passed to approve the minutes as presented in The Oil Drop.

Financial Report

Financial report was presented by treasurer, Howard Tutt. Balances, Receipts and projected Barber expenses were provided to those in attendance. A motion was made, seconded, and passed to accept the financial report as read.

(Continued on page 2)

VCE Meeting Minutes (cont.)

Dues for 2017 are now due. To make a payment for dues or to register for Barber, please send your check to our Treasurer:

Howard Tutt
1945 Linden St.
Leeds, AL 35094

Committee Reports

Springfest

There was a solicitation for more people to work next year's Springfest. It will be the same weekend. It was reported that a couple of people had credit cards compromised at different locations in Helen this year.

Corvairs at Barber

This issue will explain the event in detail.

Membership

Mike Clark, who lives south of Atlanta, is joining the club. Chris Johnson from Hueytown is also joining. Welcome, Mike and Chris!

Old Business

The DAR needs as many Corvair convertibles as we can supply for the Birmingham Veterans Day Parade.

New Business

The Shelby County College/Career center show is tomorrow. Russ is taking 5 cars. At least 4 VCE members are going. Proceeds send students to a national competition for tech schools. Please see the upcoming events for other items.

Drawings

The \$30 gas money was won by Russ Thuleen.

Next Meeting

The next meeting will be Friday, June 16, at Fullness Christian Fellowship.

Adjourn

The meeting was adjourned at 8:38 PM.

Corvairs at Barber STATISTICS

50 Registrations with 5 no shows, 100 name dash plaques were made (sorry Danny).

5 clubs were represented from 6 states.

26 Corvairs in the parking lot at the Hotel.

20 cars participated in the Parade Laps with 1 to 4 people in the cars.

Old Corvair friends and new Corvair friends enjoyed great fellowship.

The weather was absolutely perfect on both days.

There were two \$200 gift certificates from Coker tire and three Corvair Floor mat sets given away along with many other nice door prizes.

Russ Thuleen won the 50/50 drawing.

Our guest speaker and awards presenter was TV and radio personality, Sam Memmolo from the Velocity Channel and Sam's Garage Radio Show. He and His wife Diana joined us Saturday afternoon.

Pictures of the awards presentations are on page 8.

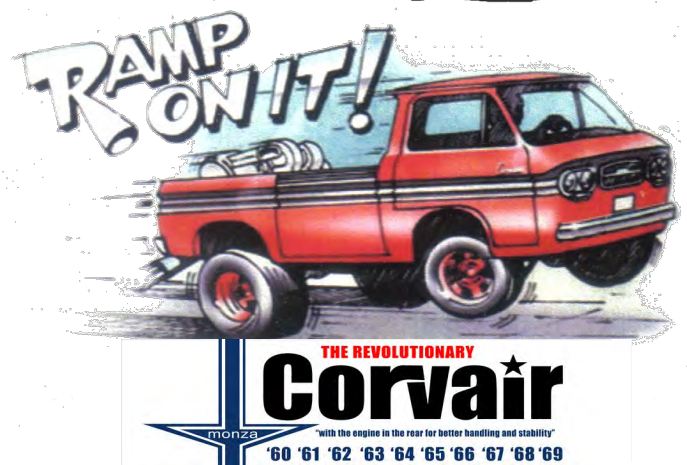
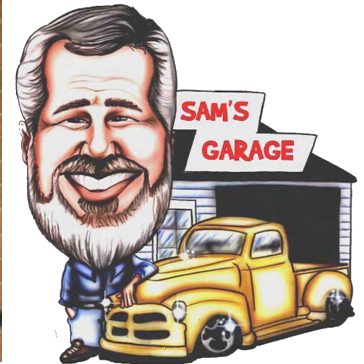

Happy Anniversary
Claudia & Howard Tutt –
June 1

Happy Birthday
Ed Lindsay – June 16



Send Oil Drop submissions to:

GTOChief@gmail.com

Office: 256-839-1905

Cell: 256-404-5998

NOTE: PLEASE SEND SUBMISSIONS NO LATER THAN THE 25TH OF THE MONTH.

VCE IS on Facebook...Click on the link:

[Vulcan Corvair Enthusiast FB Page](#)



FRIDAY



The Host Hotel provided ample parking and general public visibility for all the Corvairs



Heading out for 'familiarization run'.



CORSA is now on [Facebook](#)



SATURDAY

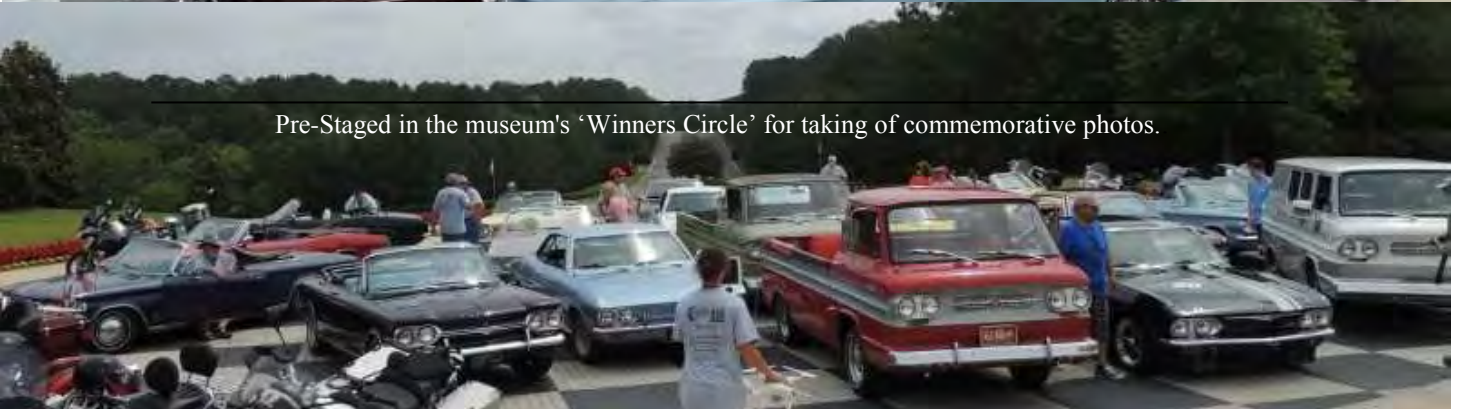

Pre-Stage in the museum's 'Winners Circle' for taking of commemorative photos.

PARADE LAPS



When Vulcan Corvair held their first mini-convention, we got to take a parade lap around the track at Talladega before the Winston 500 race. I was 16 years old, and my dad let me drive his Corsa. In those days, nobody drove that car but him, so it was a special treat that he let me take the wheel going around the track. 40+ years later, Vulcan Corvair finally did another parade lap, this time at Barber Motorsport Park. I planned to drive my Spyder around that track, but wasn't able to get it running in time. We still have that old Corsa, but it hasn't run in years and is patiently waiting its turn to be put back on the road. So, we took the trip in my sister's car, a '66 Monza coupe. I say it is my sister's car, actually it now belongs to my nephew Daniel. He is 14 years old, the same age I was when I got my Spyder all those years ago. It was a special treat for me to drive his car around the track, and have him ride along. The drive I made when I was 16 was a memory to last a lifetime, and I know this one will be as well remembered.

Phil Hartline, May 31 2017

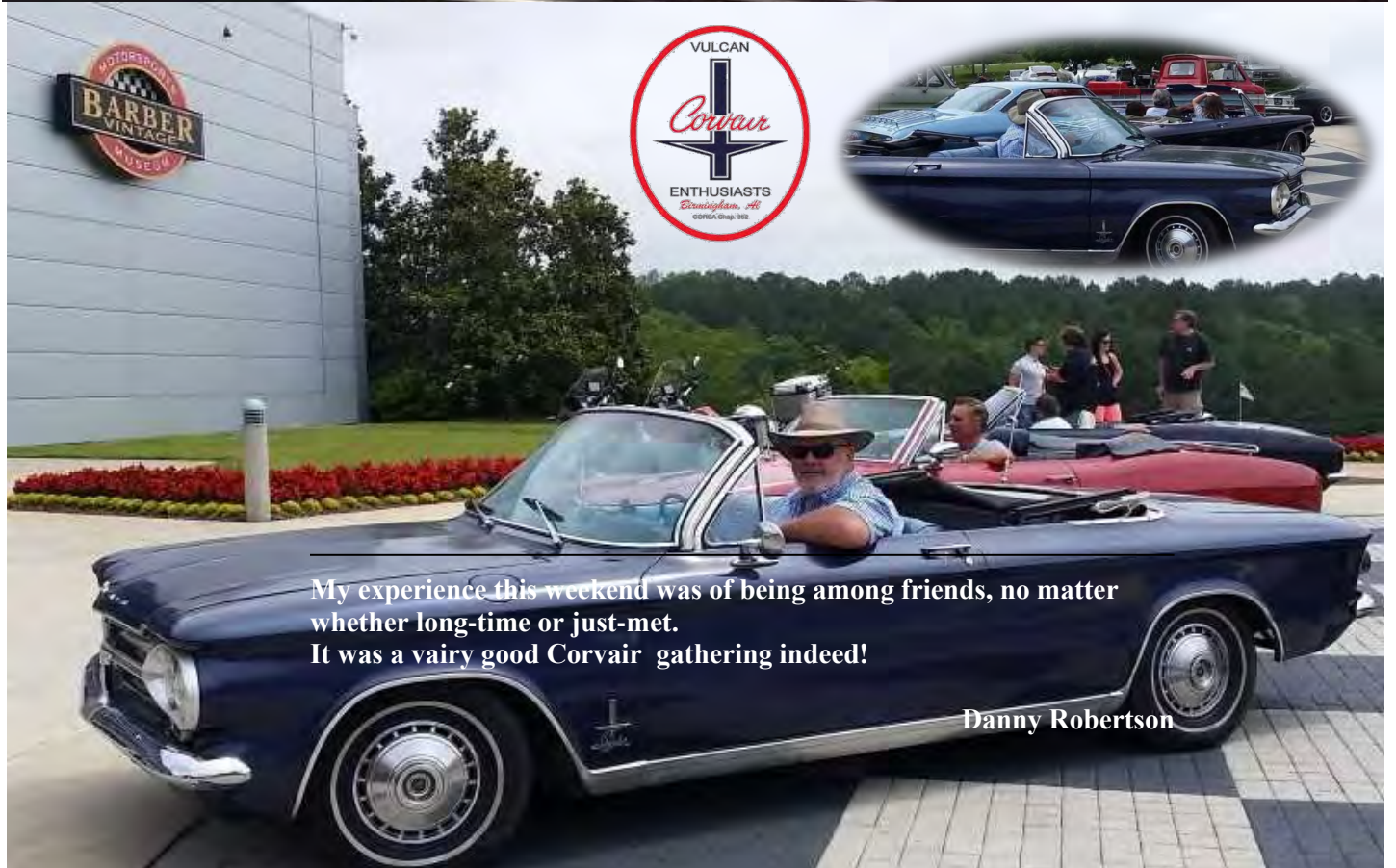

My experience this weekend was of being among friends, no matter whether long-time or just-met.

It was a vairy good Corvair gathering indeed!

Danny Robertson

THIS is what a successful event is all about:

Ed and Carol Keller, Harold, Robin & Louise Hartline, Eleanor & Billy Bruce, Sandra & Richard Sande, Richard Stolzman, Tyler Swearingen, Travis Lowery, Leslie & Russ Thuleen, and Olivia, Kayli & Lexi Williams.





BARBER MOTORSPORTS PARK:
PHOTOGRAPHY PROVIDED BY:



DashCam
Cindy Cannon and Brenda Epperson entering Barber Motorsports Park



First thing we see is a beautiful view of the on track waterfall.



DashCam
Middle straight view of the grandstands and VIP suites



Participants relax inside museum as we wait for track to clear



Phil Hartline and John Cleveland exit turn #8 in front of museum viewing area



Forward Control:

Billy Rudolph
Greg Blakeney
George Miljus



Late Closed:

Harold Hartline
Russ Thuleen
Scott Ham



Late Open:

Jim Guider
Travis Lowery

Early Open

Eleanor Bruce
Ed Keller



Specialty:

Paul Liewellyn





Leeds First Baptist Church

Provided their Fellowship Hall and Kitchen Services. Many thanks to John, Richard, Carol, and Brenda for volunteering to serve up the delicious food.



Harold met a new friend!



Hospitality Room:

ALWAYS A GOOD TIME AND PLACE TO CATCH UP WITH OLD FRIENDS AND MAKE NEW CORVAIR ACQUANTICES.



Russ won the 50/50.....



Have you ever 'Herded Cats'?



Kayli has her eye on you!

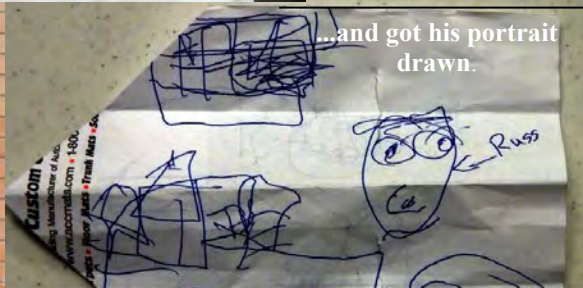

...and got his portrait drawn.

Vulcan Corvair Enthusiasts

Will see you for *Corvairs* at Barber Motorsports Park 2018

Advertising with Lisa

Phone: (229) 883-6677

E-Mail: adwithlisa@bellsouth.net





COMPUTERS

706.660.0430

BlackSheep Customs

Hydrographic Water Transfer Printing
&
Powder Coating
Childersburg, Al (256)378-3016



THE EXECUTIVE BOARD



Our 44th Year!

Get the 2013-2018 Catalog

If you did not get the catalog in 2015 or 2016, you can get one **FREE** on your first **\$50 order** during 2017. (Additional catalogs \$3 with an order)

Over 100 new repro parts in the past 3 years.

Clark's Corvair Parts®

400 Mohawk Trail

Shelburne Falls, MA 01370

(413) 625-9776 www.corvair.com



Vulcan Corvair Enthusiasts, a chapter of the Corvair Society of America, is a non-profit club dedicated to the preservation and restoration of the Corvair automobile.

VCE dues of \$20/year pay for a family membership and 12 issues of the Oil Drop Newsletter.



THE OFFICIAL NEWSLETTER OF THE VULCAN CORVAIR ENTHUSIASTS Vol 39, No. 7&8

In this Issue:

- * **SUMMER MINUTES**
- * **CHOO CHOO CLASSIC**
- * **VCE IDENTIFICATION**
- * **CORVAIR GRAPHICS**
- * **VCE Membership Application**
- * **Classifieds**

2017 VCE Officers

President:

John Cleveland
monzaiohn@charter.net
 205-834-3120

1st Vice President:

Richard Stolzmann
richey-rich_43@hotmail.com
 205-467-6444

2nd Vice President

(communications):

Billy Cannon
qtochief@gmail.com
 C: 256-743-0058
 H: 256-839-1905

Secretary:

Steve Daniels
steve_d_daniels@bellsouth.net
 C; 205-213-5935
 H: 205-995-9474

Treasurer:

Howard Tutt
hftutt@yahoo.com
 936-524-7611

VCE Mailing Address

Vulcan Corvaire Enthusiasts
 147 Crossbrook Dr.
 Chelsea, Al 35043

From the Prez:

First I'd like to welcome our newest members, Kris Johnson and his wife and Randy and Diane Stuart. Kris lives over in Hueytown and joined in June. Randy and Diane recently moved to Alabama and came to our last meeting from Aliceville. Welcome to all of you.

Next I'd like to bring your attention to the July meeting minutes, the part about getting together a new committee for our Barber event. Billy and his crew have done an excellent job laying the groundwork, making connections and learning along the way. All of them would be happy to assist with a new committee and their work will make future events a lot less difficult to put together. Please consider volunteering.

I had an interesting conversation with a fellow enthusiast who owns an early Ford station wagon. He drives the car a lot and our topic was the thrill of long trips in an old car. I've had my convertible on some 1000+ mile trips a few times and I have to agree there is something of a thrill; or it may be more of a 'Gonna make it?' feeling. Now that my car has over 75K miles on the overhaul I believe that may be replacing the 'thrill'. Also, my car is on the road almost every day and, as with most old cars, things do break. I've been very blessed that nothing serious has happened over 50 miles from home, if you don't count the oil spill at the Hardee's in Heflin...

But there are few feelings as good as getting out on the road, alone or with fellow enthusiasts, and going on a multi-day excursion. Many of you remember the trips that Pete put together for us. The Natchez Trace drive is one of my favorite Corvaire memories and the trip up through Tennessee was a close second. Maybe we can get a fall drive together, if you have some ideas send them to me. We need to start planning soon as August is almost here.

Just a few things to think about as we get ready for the fall and winter season. Remember Choo Choo is coming up soon (another chance for a long drive) and our August

Summer 2017

Next Meeting:

Date: Friday, 18 August

Time: 7:00 PM

Place: Fullness Christian Center

meeting on the 18th .

Remember, the cruise-ins and car shows are up in full force so clean it up, crank it up and get that Vair out there!!!!!!!!!!

John

VCE June Meeting Minutes

Call to Order

The meeting was called to order Friday, 6/16/17, at 7:30 PM by President John Cleveland.

Participants

With 15 members and 4 youngsters in attendance, a quorum was present.

Minutes of the previous Meeting

Minutes of the May meeting were published in The Oil Drop. Copies were distributed and reviewed by the membership before the meeting started.

Financial Report

Howard Tutt presented the financial report to those in attendance. The report was approved. To make a dues payment, please send your check to our Treasurer:

Howard Tutt
 1945 Linden St.
 Leeds, AL 35094

Committee Reports

Corvairs at Barber

Thanks to everyone who participated. It went very well. We would like larger numbers of people to be there. Due to the members from one club needing to leave early, the attendance at the Saturday dinner was less than the 50 projected. Howard presented a final expense tally of the event. A motion was made, seconded and passed to give \$100

(Continued on page 2)

VCE June Meeting Minutes (cont. from pg. 1)

to Choo Choo for their participation and assistance. The evaluation of the dinner was mixed. The chicken was good but the beef was tough. The food got a bit cool for those at the end of the line. Perhaps the decision not to start the steamer tables could be revisited for next year. Leeds Baptist Church was happy with how the event went. Some door prizes are available, as are many dash plaques. Due to a non-Corvair problem on the track, the track time was delayed. As a result, Barber gave a tremendous discount on museum admissions for everyone wearing a Corvairs@Barber name tag. ACC wants to sponsor again. It is unknown if Coker Tire wants to continue next year. Billy and Howard are meeting with Barber the week of 6/19 about scheduling for 2018. There was a discussion of purchasing a printer for the club for pictures on-site and printing for the event, which people did this year out of their own pockets. It was requested that more information be gathered before making a decision on that. John Cleveland will send thank you notes to our partners.

Membership

No changes this month.

Old Business

None

New Business

Billy Cannon suggested that we get new club shirts incorporating the Vulcan Corvair Enthusiasts logo. He was asked to get more info so the members could decide. The approximate cost would be \$20/shirt.

Tech Session

Russ Thuleen brought the 3 cylinder demonstration engine that belongs to Springfest. It started and ran nicely. Particularly interesting were the plexiglass covers for the cylinder bank that had been removed and the area over the crankcase. We then had a discussion of the 3 different alternator types and looked at some of those on our Corvairs.

Special Orders

Clyde Cork got with Danny Robertson and had plaques made for Billy Cannon, Russ Thuleen, and Howard Tutt. Their special efforts to make Corvairs@Barber a success are greatly appreciated.

Drawings

Huddle House Gift certificates: Howard Tutt, Billy Cannon, Russ Thuleen (2), Brenda Cork (2). The \$27 gas money was won by Judi Cannon.

Next Meeting

The next meeting will be Friday, July 21, at Fullness Christian

VCE July Meeting Minutes

Call to Order

The July 21, 2017, meeting was called to order at 7:30 PM by President John Cleveland.

Participants

With 15 members in attendance, a quorum was present.

Minutes of the Previous Meeting

The July edition of *The Oil Drop* was not published and secre-

tary Steve Daniels was not present so minutes of the June meeting were distributed and available to members present for review. A motion to accept the minutes was made by Richard Stolzmann, seconded by Danny Robertson, and passed unanimously.

Financial Report

The financial report from Treasurer Howard Tutt was given to those in attendance. He reported that, as of this date, all bills have been paid with nothing outstanding. A motion to accept the financial report was made by Clyde Cork, seconded by Billy Cannon, and passed unanimously.

To make a dues payment, please send your check to our Treasurer:

Howard Tutt
1945 Linden St.
Leeds, AL 35094

Committee Reports

Corvairs at Barber

Howard Tutt met with Michael DeSocio of the Barber Vintage Motorsports Museum concerning the 2018 event. He reported that everything will be much as it was this year except for the location to pre-stage the Corvairs and that every weekend in the month of May 2018 is available. Much discussion followed about choosing the proper weekend for the event and was eventually tabled until we have more facts before committing to a date. An offer of the opportunity to form a 2018 Barber committee within the next couple of months was mentioned and agreed upon. John Cleveland sent 'Thank You' cards to Barber Motorsports, Hampton Inn, and Leeds 1st Baptist church for their support of our event.

Old Business

John Cleveland reported that they visited the Coyote Drive-in in Leeds. It is nice and very big with a playground, miniature golf, and a restaurant/bar with pool tables quite a walk from the screen.

Billy Cannon announced that he, Howard Tutt, and Russ Thuleen brought the Springfest Grill from Georgia as we agreed to store and maintain it. Modifications are to be done prior to next year's event.

A \$100 check was sent to the Choo Choo club for their members participation during the Barber event.

Discussion about purchasing a photo color printer for award production convenience was tabled.

Billy provided a vendor catalogue for shirt selection as part of the request for further information on procuring new club apparel. Discussion of price and selection continued resulting in a price point of approximately \$20 per shirt for each member that would like to order. \$60 one-time three color screen set up fee with a minimum order of ten units is required by the vendor. (Next order of ten would not charge the set-up). An announcement will be placed in upcoming newsletters with shirt styles, color and availability for ordering.

Membership

New members Randy & Diane Stuart from Aliceville, AL, were welcomed and given the club patch and Barber Dash plaques. They drove to their first VCE meeting in their 1966 Monza Coupe. Kris Johnson, who was not in attendance, is also a new member. He has a '63 coupe. Russ Thuleen and

(Continued on page 3)

VCE July Meeting Minutes (cont.)

John Cleveland went over to his house and helped him with a few minor issues he is having with his car. Russ mentioned that he was going over to another new member's (Richard Broome's) home in Inverness, Saturday, July 22, to meet him and check out his Corvair.

Russell Noble brought up that having a stack of club fliers would be helpful at cruise-ins and car shows to hand out to folks. We once did this. Russ and John stated that they had several left over and would make them available. We will also scan one and reproduce as necessary.

New Business

John Cleveland received a proposal from Lillian Law to change concourse judging at Springfest to a "Presidents Choice" format. The proposal was accepted as written by membership vote.

Tech Session

None.

Drawings

The \$26 gas money drawing was won by Carol Keller.

Next Meeting

The next meeting will be August 18 at our regular location, Fullness Christian Fellowship.

Adjourn

The meeting was adjourned at 8:22 PM so that we could and see Randy & Diane's Corvair.

Events

Future Events

Date	Event	Place
8/11-12/2017	Choo Choo Classic	Chattanooga, TN
10/6-7/2017	Vairs at the Fair	Warner Robins, GA
10/13-14/2017	Vairs in the Valley	Maggie Valley, NC



Happy Anniversary

Denise & John Cleveland – July 29
June & Ed Lindsay – July 30
Louise & Harold Hartline – August 1

Happy Birthday

Ski Johnson – July
John Cleveland – July 26
Al Hilderbrand – July
Ed Keller – July 2
Marshall McDuffie – July 6
Russell Noble – July 17
Chris Brown – August 6



T shirts I have - 50

T shirts I wear - 5



T shirts I am willing to give away - ZERO



Send Oil Drop submissions to:

GTOChief@gmail.com

Office: 256-839-1905

Cell: 256-404-5998

VCE IS on Facebook...Click on the link:

[Vulcan Corvair Enthusiast FB Page](#)

CORSA is now on [Facebook](#)

NOTE: PLEASE SEND SUBMISSIONS NO LATER THAN THE 25TH OF THE MONTH.

2017 CHOO CHOO CORVAIR CLASSIC REGISTRATION FORM

Hosted by CHOO CHOO CORVAIR CLUB

August 11-13 2017

At the Historic Chattanooga Choo Choo, Chattanooga, TN

Name: _____ Spouse: _____
Address: _____
Phone: _____ City: _____
State: _____
Email: _____ Zip: _____
Club Affiliation: _____
Names of Children in your group: _____

YOU MUST BE REGISTERED TO TAKE PART IN ANY EVENT
REGISTRATION FEE: \$15.00 PER PERSON; \$30.00 PER FAMILY.....\$ _____
SATURDAY ONLY \$10.00 PER PERSON; \$20.00 PER FAMILY.....\$ _____
VENDOR FEE: 10.00 PER TABLE (OUTSIDE SPACE).....\$ _____
PEOPLES CHOICE: \$8.00 PER CAR.....\$ _____
AWARDS BANQUET & BUFFET: \$33 PER ADULT.....\$ _____

TOUR OF CHATTANOOGA FRI 2PM..... _Yes No_
Corvairs leave CHOO CHOO.....2PM for 45 minute tour of Chattanooga to the River Front for HOSPI-
TALITY WITH MUCH FOOD and DRINK!!!!
PEOPLES CHOICE REGISTRATION (ALL CARS WILL BE ON DISPLAY WILL BE JUDGED FOR PEO-
PLE'S CHOICE)
VEHICLE DESCRIPTION: year ___ color ___ model _____

___early open ___early closed
___late open ___late closed
___forward control ___specialty

Liability clause: Entrants and participants by execution of this form release and hold harmless Choo Choo Corvair Club, Inc., Choo Choo Corvair Club members and officers, Chattanooga Choo Choo, Inc. and anyone else connected with the management or presentation of this show from any and all known damages, injuries, losses, judgments, and /or claims from any causes whatsoever that may be suffered by any entrant or participants to his or her personal property (including family members and friends)

REGISTERED GUEST _____ INT _____ SIGN _____ INT _____
SIGN

HOTEL REGISTRATION: MENTION CHOO CHOO CORVAIR FOR DISCOUNT RATE CHOO CHOO HO-
TEL (423)266-5000
JIM GUIDER (423)242-8155.....MELVIN HOPKINS (706)217-5123



Vulcan *Corvaair* Enthusiasts



40th Anniversary 1974-2014



Vulcan Corvaair Enthusiasts



Birmingham, Alabama

Corsa Chapter. 352

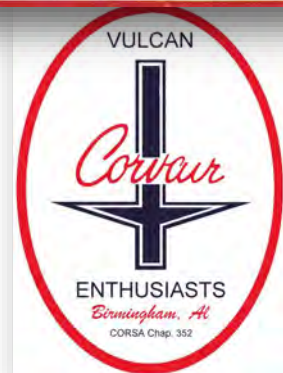

VCE Identification:

Our club has been in existence since 1974.

Above are a examples of the first and current patch, dash plaque, 40th anniversary t-shirt, banner and 'futuristic' logo.

Covair Vehicle Identification:

Line drawings, cartoons and graphic examples of Chevrolet's amazing design teams.



Cruisin'
USA





Please consider my application for membership in the Vulcan Corvair Enthusiasts
A Chartered Chapter of CORSA (Corvair Society of America), Chapter 352

Date of Application: _____

Submit application to:
Howard Tutt
1945 Linden St.
Leeds, AL 35094

Or better yet, come to a meeting the third Friday of each month at Fullness Christian Fellowship at 2575 Columbiana Rd., Birmingham, AL 35216.

Information About You			
First Name		Last Name	
Address			
City		State	
Zip		Phone	
Email address			
Family Member(s) to be listed with the Vulcan Corvair Enthusiasts Membership			
First Name		Last Name	Birthday (mm/dd/yyyy)
Anniversary			
Information about your Car			
Year		Color	Type
Horsepower		Other	Engine CI

MEMBERSHIP DUES ARE \$20.00 PER YEAR PER FAMILY, DUE JAN. 1

Initial Dues Pro-rated by Quarter (Jan-Mar: 100%, Apr-Jun: 75%, Jul-Sep: 50%, Oct-Dec: 25%)

Are you a member of Corsa? Y / N

Signature: _____

CLASSIFIEDS

1961 Corvair 47,000 actual miles. Engine has been disassembled to replace all gaskets and seals. Body-VG. No rust-outs. Interior-VG. Includes 2 complete parts cars and many NEW and USED parts. \$1,000. Talladega, AL (205) 266-7675 **PRICE DROP TO \$500**

Russ and I dropped by and talked with William and took these pictures back in late 2015. He asked that I repost. If they don't sell at this price he is going to SCRAP them! He has the p'work to prove the mileage on this car. A unique example...the original owner only wanted ONE option and she chose the PG.



William Browning
Talladega, AL (205) 266-7675 Email: corvair700@cloud.com

Our 42nd Year!

Get the 2013-2018 Catalog

If you did not get the catalog in 2015 or 2016, you can get one **FREE** on your first **\$50 order** during 2017. (Additional catalogs \$3 with an order)

Over 100 new repro parts in the past 3 years.

Clark's Corvair Parts[®]
400 Mohawk Trail
Shelburne Falls, MA 01370
(413) 625-9776 www.corvair.com

Vulcan Corvair Enthusiasts, a chapter of the Corvair Society of America, is a non-profit club dedicated to the preservation and restoration of the Corvair automobile.

VCE dues of \$20/year pay for a family membership and 12 issues of the Oil Drop Newsletter.



THE OFFICIAL NEWSLETTER OF THE VULCAN CORVAIRE ENTHUSIASTS Vol 39, No. 9

In this Issue:

- * **CHOO CHOO CLASSIC**
- * **HELENA Museum**
- * **1965 Greenbrier**
- * **1964 Corvan**
- * **VCE Membership Application**
- * **Classifieds**

2017 VCE Officers

President:

John Cleveland
monzaiohn@charter.net
 205-834-3120

1st Vice President:

Richard Stolzmann
richey-rich_43@Hotmail.com
 205-467-6444

2nd Vice President (communications):

Billy Cannon
qtochief@gmail.com
 C: 256-743-0058
 H: 256-839-1905

Secretary:

Steve Daniels
steve_d_daniels@bellsouth.net
 C: 205-213-5935
 H: 205-995-9474

Treasurer:

Howard Tutt
hftutt@yahoo.com
 936-524-7611

VCE Mailing Address

Vulcan Corvaire Enthusiasts
 147 Crossbrook Dr.
 Chelsea, Al 35043

From the Prez:

First a follow up from last month's letter. Pete Wood was at the August meeting so I asked him about information he gathered for the Natchez Trace trip the club took several years ago. I first hope was that he would give me all the details off the top of his head, which didn't happen. The second hope was that he would send me the information so I could see if I could pull this trip out of the hat in time for fall foliage. That didn't happen either. Seems Pete's vehicle was broken in to and the computer he had all the club trips stored on was one of the items taken. Worse still the backup drive was with the computer so there was no hope of retrieving all the work he put in to those trips. A huge loss for Pete and for the club. I'll repeat me request from last month; if anybody had an idea for a fall foliage tour let me know and we'll see if we can put something together. A day outing of overnight would be great.

Next an update from the garage. It's been carburetor rebuilding time at my house the last couple of weeks. I have been collecting carbs for a couple of years and had purchased kits for the ones I thought were savable. Several had bad mineral deposits in them from being exposed to the elements, to the point the small passages were completely clogged up and the choke and throttle shafts were frozen up. These I ended up salvaging what I could and tossing the bodies. There were a couple I've been working on drilling out the larger holes to try to salvage them. One is a 140 secondary and the other is a pre '65. I'd like to save the secondary and hope I can save the early for somebody who might need it. So far I have four late model primaries rebuilt and ready to go.

With September just around the corner start thinking about Warner Robins and Maggie Valley. Time does fly and those dates will be here before you know it. Billy has probably got those dates elsewhere in the newsletter. See you at the next meeting on Sept. 15. Remember, clean it up, crank it up and get that Vair out there!!!!!!!
 John

September 2017

Next Meeting:

Date: Friday, 15 September

Time: 7:00 PM

Place: Fullness Christian Center

Happy Anniversary

Teresa & Marshall McDuffie – Sept 1

Carol & Ed Keller – Sept 27

Happy Birthday

Judi Cannon – Sept 10

June Lindsay – Sept 2

Caroll Hartline – Sept 22



VCE August Meeting Minutes

Call to Order

After a delightful dinner, the August 18, 2017, meeting was called to order at 7:30 PM by President John Cleveland.

Participants

With 15 members in attendance, a quorum was present.

Minutes of the Previous Meeting

The *Oil Drop* containing the minutes of the last meeting was distributed to the members for review. A motion to accept the minutes was made by Sherri Daniels, seconded by Russ Thuleen, and passed.

Financial Report

The financial report from Treasurer Howard Tutt was given to those in attendance. He reported that CORSA is paid for the year. The only remaining bill is the 4th quarter meeting room rental for Fullness Christian Fellowship. A motion to approve the treasurer's report was made by Steve Daniels, seconded by Russ Thuleen, and passed.

To make a dues payment, please send your check to our Treasurer:

Howard Tutt
1945 Linden St.
Leeds, AL 35094

Events

Choo Choo Classic

Eight members went to Choo Choo. Congrats to both Danny Robertson and Kevin Fahy for winning awards for their Vairs! Russ successfully recovered from losing one brake hose on the way back. We reviewed slides from the show. A highlight was an unrestored 1965 8-door Greenbrier. Our thoughts go out to Choo Choo's Jim Guider, who is ill.

Committee Reports

Corvairs at Barber

The Barber committee was re-formed with Billy Cannon, Howard Tutt, Danny Robertson, and Russ Thuleen as initial members. Others will be recruited. After looking through the calendar and other events, the club gave direction to the committee to pursue May 18-20 for Corvairs at Barber 2018. That avoids the Barber Indycar race, the Talladega NASCAR race, Mother's Day, and Memorial Day.

We're looking into a Friday Drive-In movie night before the activities start Saturday at Barber. If you have a car or Corvair-themed movie you'd like to see, send your suggestion to a committee member.

Old Business

Club Shirts

The ladies chose the feather weight t-shirts with the Corvair graphic on the left front. The men chose the pocket T-shirt and the polo with pocket. Color can be chosen at time of ordering. There's a \$60 set up fee. The prices on the shirts would be about \$20/shirt once the setup fee is factored in. If the setup fee is paid by the club, the price per member drops to the price of the shirt, roughly \$10 - \$16.

A motion to have the club pay for the setup fee was made by Billy Cannon, seconded by Howard Tutt, and passed unanimously.

Billy Cannon will bring an order form to the next meeting. In the meantime, we can visit:

Future Events

Date	Event	Place
9/23/2017	Heartland Cruisers Car Show	Tannehill State Park, McCalla, AL
10/6-7/2017	Vairs at the Fair	Warner Robins, GA
10/13-14/2017	Vairs in the Valley	Maggie Valley, NC

<http://www.advertisingwithlisa.com/> to get more info.

Printer for the Club

There was a discussion of the utility of purchasing a photo printer for shows. A motion to purchase a Canon SELPHY CP1200 Wireless Color Compact Printer w/ink for approximately \$150 was made by Billy Cannon, seconded by Howard Tutt, and passed unanimously.

Membership

Copies of the membership roster were distributed.

Ken Barfield (205-265-8180 at 300 Pediatric Driver, Jasper, AL) is interested in joining the club. We look forward to hopefully seeing Ken at a meeting or event in the future.

New Business

CORSA President, Danny Davis contacted us about cataloging and assessing items donated to The Corvair Preservation Society (CPF) by the late Barry Taylor of Wetumpka, AL. According to the family, items included are a station wagon, a coupe, a convertible and many parts.

When arrangements are made with CPF, club members will go to Wetumpka to examine the inventory.

Tech Session

None.

Drawings

A copy of "Unsafe at Any Speed" was won by Russ Thuleen. The \$27 gas money drawing was won by Judi Cannon.

Next Meeting

The next meeting will be September 15 at our regular location, Fullness Christian Fellowship.

Adjourn

The meeting was adjourned at 8:25 PM.





Choo Choo Classic 2017



Howard's Monza



Richard's Corsa



Kevin's Monza



Danny's Spyder



Russ's Turbo Rampside



Bill's Corsa



Billy's 140 Rampside

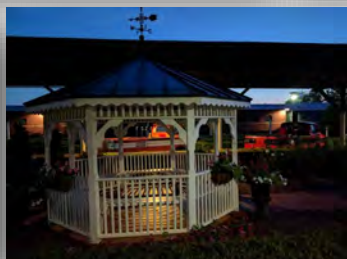

Helena Museum:

An article from Dixie Vintage Newsletter contributor, Gary Adams. Submitted to the Oil Drop by Russell Noble.

On my 2nd visit to the Helena Museum my guide was Rock McCulley. Rock had been telling me about the new Helena Drag Strip exhibit in the museum and I was anxious to see it. The exhibit includes old photos, trophies, and old articles about the famous drag strip. According to a February, 2016 article in the Helena Reporter by Graham Brooks, the drag strip was open in the 50s and 60s and the most famous racer to visit was probably Don Garlits. The article goes on to say that many of the artifacts in the exhibit were donated by Charles Griffin and Charles Portera. Included herein are a few photos of the exhibit photos. The Willis coupe shown below was owned and raced by Sully Sullivan who still lives in the area. The 1954 Ford was owned and raced by RE Smith. The Helena Museum, located at 5260 Helena Road, Old Town Helena, is open Saturdays and by reservation. Please call 205-369-1448 for information. Don't miss it.



The 1965 Greenbrier (and it's an 8 door too)!

(Much of the content here is from an original article in the January 1982 *Communiqué* written by Bill Borland, Valley CORSA)

The 2017 Choo Choo Classic produced some amazing firsts for those in attendance. The best of all (in my opinion) was the completely original 2 owner 1965 eight door Greenbrier owned by the Neal Menanno family from Brentwood, TN.

Neal, his wife, two toddlers and baby, drove the Greenbrier down and it was an immediate crowd pleaser for everyone. YES, it is an ORIGINAL '65 Greenbrier Deluxe and certainly an eight door. (I checked...several times!) The other amazing thing is that the van survived the original owner that had 13 kids. And it is a survivor: Original upholstery, floor mats, sunvisors, arm rests, EVERYTHING in very good condition. Neal reported that it ran and behaved in the 90 plus degree weather like a dream.

When was the last time you saw a baby's diaper changed on the engine cover with the back doors opened....perfect changing table.



'sports wagon' to compete with the Ford Falcon wagon. They were able to get the Chevy Van in production in time for the 1965 model run, but not their sports wagon at that time; so, to fill the gap until the sports wagon was available, Chevy continued the Greenbrier into the 1965 model run until December of '64. At which time the Chevrolet Sports wagon became available.

Total production of 1965 Greenbriers was 1,528.

Although the '65 Greenbrier was only a fill-in until the sports model became available, it still had a lot of features that were not available on the '64; among them were: a new ignition switch similar to the ones used in the '65 cars (except it didn't have an accessory position), a new turn signal switch (the same as used on the '65 cars), an alternator, new arm rests, a new horn ring, new body side emblems (these were placed in the area where the white stripe is), and the early model car 100-mph speedo was used.

The 1965 Greenbrier could be ordered with doors on the left (drivers) side, a deluxe interior, a gas heater, and any of the options previously offered. The 1965 Greenbrier owner's operating instructions were included in the 1965 passenger car manual.

Several years back, Vulcan Corvair Enthusiasts club members cleared the April 27th devastation on Bob and Wilma Siemens's property. Among many of the damaged Corvairs was a very rare 1965 Greenbrier which we pulled from under the aluminum shed where it was stored. The major damage was to the cab area, windshield, and buckled roof. Russ Thuleen, is in possession of the Greenbrier (also a Deluxe) and has it running and driving but we still need to help him with the damaged roof. Quite a few people do not realize that a Greenbrier was made in 1965. My first thought was that Chevy had a lot of 1964 bodies left and wanted to use them up. Actually, the real reason for the 1965 Greenbrier was that there happened to be an Iron Workers strike and Chevrolet was coming out with a new



The 1964 Corvan (and it's an 8 door too)!

(Many THANKS to Chris and Molly for trusting us with getting this one "Back on the Road") T2C

The 'More Door' van pictured here is a shared undertaking with lots of ideas on how to utilize it for the benefit of the Vulcan Club and Springfest. We will probably settle between a display for the 3 cylinder engine and/or a tow vehicle for the cooker.

Right now it is in the tear down and assessment phase and looks very promising. A 110 hp engine from inventory has been identified and will go in over the winter.

STAY TUNED



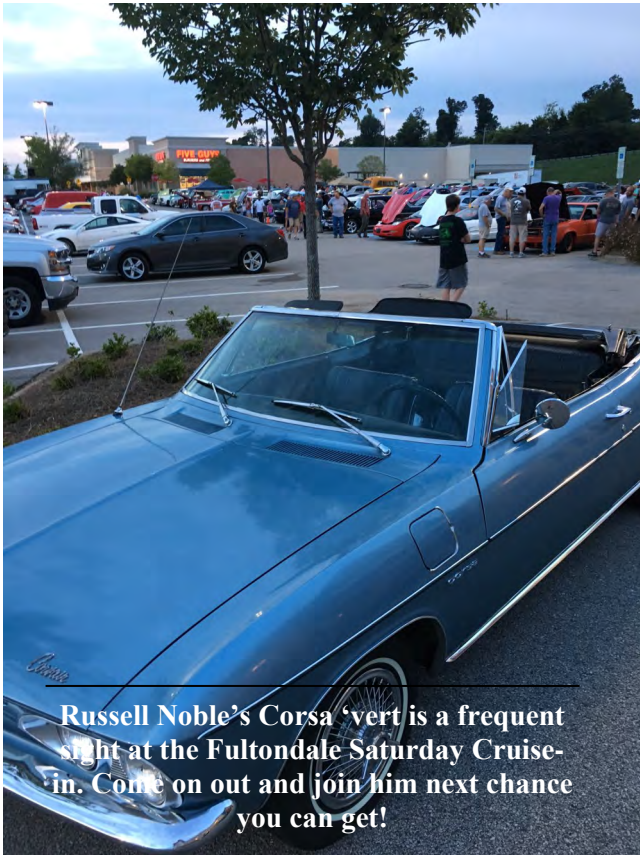

Russell Noble's Corsa 'vert is a frequent sight at the Fultondale Saturday Cruise-in. Come on out and join him next chance you can get!



Howard Tutt's Monza Coupe under the lights and in the garden at Choo Choo Classic 2017



1965 CHEVROLET CORVAIR GREENBRIER SPORTS WAGON

Vulcan Corvair Enthusiasts



Birmingham, Alabama

Corsa Chapter. 352



THE REVOLUTIONARY

Corvair

"with the engine in the rear for better handling and stability"

'60 '61 '62 '63 '64 '65 '66 '67 '68 '69

Send Oil Drop submissions to:

GTOChief@gmail.com

Office: 256-839-1905

Cell: 256-404-5998

VCE IS on Facebook...Click on the link:

[Vulcan Corvair Enthusiast FB Page](#)

CORSA is now on [Facebook](#)

NOTE: PLEASE SEND SUBMISSIONS NO LATER THAN THE 25TH OF THE MONTH.



Please consider my application for membership in the Vulcan Corvair Enthusiasts
A Chartered Chapter of CORSA (Corvair Society of America), Chapter 352

Date of Application: _____

Submit application to:
Howard Tutt
1945 Linden St.
Leeds, AL 35094

Or better yet, come to a meeting the third Friday of each month at Fullness Christian Fellowship at 2575 Columbiana Rd., Birmingham, AL 35216.

Information About You			
First Name		Last Name	
Address			
City		State	
Zip		Phone	
Email address			
Family Member(s) to be listed with the Vulcan Corvair Enthusiasts Membership			
First Name		Last Name	Birthday (mm/dd/yyyy)
Anniversary			
Information about your Car			
Year		Color	Type
Horsepower		Other	Engine CI

MEMBERSHIP DUES ARE \$20.00 PER YEAR PER FAMILY, DUE JAN. 1

Initial Dues Pro-rated by Quarter (Jan-Mar: 100%, Apr-Jun: 75%, Jul-Sep: 50%, Oct-Dec: 25%)

Are you a member of Corsair? Y / N

Signature: _____

HESCO'S HOBBY SHOP

Wood Crafts by Corvair Enthusiast, David Hausenfleck
David does Jewelry Boxes, Birds of Prey, Dragons, Classic Cars, Corvairs, Plaques and other
Wood Crafts Special Order.

256-525-5087

<http://www.facebook.com/hescoshobbyshop>

hesco@att.net



Our 42nd Year!

Get the 2013-2018 Catalog

If you did not get the catalog in 2015 or 2016, you can get one **FREE** on your first **\$50** order during 2017. (Additional catalogs \$3 with an order)

Over 100 new repro parts in the past 3 years.

Clark's Corvair Parts[®]
400 Mohawk Trail
Shelburne Falls, MA 01370
(413) 625-9776 www.corvair.com



Vulcan Corvair Enthusiasts, a chapter of the Corvair Society of America, is a non-profit club dedicated to the preservation and restoration of the Corvair automobile.

VCE dues of \$20/year pay for a family membership and 12 issues of the Oil Drop Newsletter.



THE OFFICIAL NEWSLETTER OF THE VULCAN CORVAIR ENTHUSIASTS Vol 39, No. 10

In this Issue:

- * **BARBER ANNOUNCEMENT & COMMITTEES CALL**
- * **Howard's Search**
- * **Vairs at the Fair**
- * **The Corvair Tractor**
- * **VCE Membership Application**
- * **Travelling BillBobbery**
- * **Classifieds**

2017 VCE Officers

President:

John Cleveland
monzajohn@charter.net
 205-834-3120

1st Vice President:

Richard Stolzmann
richey-rich_43@hotmail.com
 205-467-6444

2nd Vice President (communications):

Billy Cannon
qtochief@gmail.com
 C: 256-743-0058
 H: 256-839-1905

Secretary:

Steve Daniels
steve_d_daniels@bellsouth.net
 C: 205-213-5935
 H: 205-995-9474

Treasurer:

Howard Tutt
hftutt@yahoo.com
 936-524-7611

VCE Mailing Address

Vulcan Corvair Enthusiasts
 147 Crossbrook Dr.
 Chelsea, Al 35043

From the Prez:

Fall is in the air! It's darker when the convertible and I go to work in the morning and the afternoon sun definitely has that fall shimmer. It has also been cooler and a lot dryer than the summer which is great for putting the top down and enjoying owning a convertible!

As fall and the holidays approach the club has several things we need to be thinking about and acting on. Vairs at the fair is coming fast, Oct. 6 and 7 is next weekend. Information is on our facebook page and the CORSA web site. Maggie Valley is the following weekend so October is a busy month for some quality Corvair shows.

November brings the show at Lineville, AL the first Sunday in November. If you've never seen hundreds of classic cars gathered in one place I highly recommend this show. We have had a contingent going to this one for several years and it is definitely worth it. The money goes to the Shriner's and that's worth it too.

Also coming up in November is the Veteran's Day parades in Anniston and Birmingham on November 11, a Saturday. I have asked for some Corvair convertibles to support the Alabama Daughters of the American Revolution in the Birmingham parade and as always the club supports the veteran's organization in Anniston. There's still time left to sign up for Birmingham. Notify me with your car information including make, year, tag #, color, driver's name and license number. Because of the size of this parade officials are requesting this information for increased security. Notify Billy Cannon if you are planning on going to Anniston for that parade so he can have a head's up on the number attending. These are both great opportunities to support our veterans and to support our club and our cars.

With December comes our club Christmas party and election of officers. There was some discussion about the party at our last meeting. One suggestion that got a lot of support was having the party at a restaurant that has a banquet room. Since there wasn't

October 2017

Next Meeting:

Date: Friday, 20 October

Time: 7:00 PM

Place: Fullness Christian Center

enough attendance at the meeting to do any official business I assigned Russ and Howard to look in to a couple of venues by executive order. They will report back to the group at our October meeting on the 20th. Dues are due in December also and we usually take up donations for a charitable cause. The recipient of that donation will be on the agenda at our October meeting.

Last but certainly not least is our preparations for Barber 2018. Howard has sent out information and is asking for volunteers so he can start getting slots filled for everything that needs to be done. The committee is looking at alternate motels and banquet rooms in the area and any and all ideas. Remember, clean it up, crank it up and get that Vair out there!!!!!!!!!!

John

NO VCE Meeting Minutes were recorded for last month!

Happy Anniversary

- Emily & Pete Wood – October 17
- Sherri & Steve Daniels – October 18
- Judi & Billy Cannon – October 30

Happy Birthday

- Phil Hartline – October 8
- Rozelle Doughty – October 10
- Debbie Noble – October 14
- Howard Tutt – October 23
- Steve Daniels – October 24
- Harold Hartline – October 27

OLD CORVAIRS NEED LOVE TOO!

Let's Face It! Your Corvair is indeed a great car!

Did you know that there is a group of enthusiastic Corvair lovers in this area?

See other side for details. . .



PLACE
POSTAGE
HERE

To: _____

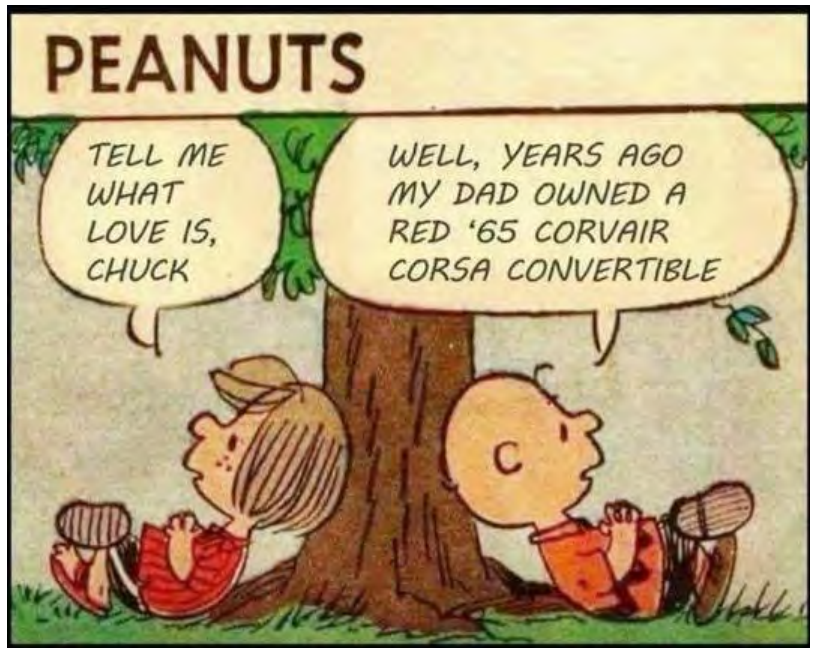

The Corvair Society of America (CORSAs), Inc. is a club formed in 1969 by and for those who still appreciate the Corvair automobile. The club has grown to include more than 6,000 members nationwide.

The Birmingham Chapter of CORSAs, the Vulcan Corvair Enthusiasts, has over 50 members who meet regularly to continue efforts to keep the Corvair alive.

For further information, detach the return mail card, fill in your name, etc., and mail it right away. Your response does not obligate you in any way to join our club (but we hope that you will!)

If you prefer, call _____ at _____

YES! I am interested in learning more about the Vulcan Corvair Enthusiasts club.

Name _____

Address _____

Phone _____

I own _____ Corvair (s).

THIS REPLY DOES NOT OBLIGATE ME IN ANY WAY.



Future Events

Date	Event	Place
10/6-7/2017	Vairs at the Fair	Warner Robins, GA
10/13-14/2017	Vairs in the Valley	Maggie Valley, NC
11/11/2017	Veterans Day Parades	Birmingham & Anniston, Al





Barber 2018 Committee Call

Please look over the committee list below and be prepared to add your name to our committee(s) at our October 20th meeting. So your talents can best be utilized, a brief description of each responsibility is shown below each committee.

Registration: B. Cannon, C.Tutt, L.Thuleen

Register and distribute information and T shirts

Advertising Sales: Banner/"T" shirt H.Tutt, _____, _____

Our budget needs approximately \$500 in advertisement sales in order to break even. We can target auto part dealers , oil change providers, etc... All necessary brochures and pricing data will be provided.

"T" shirt: B. Cannon, _____

"T" shirt design and advertisement placement on T shirt. Order T shirts.

Banner: D. Robertson, _____

Banner design and advertisement placement.

Movie: J. Cleveland, R.Thuleen, _____

Movie choice and coordination with drive in. Also car show coordination with theater.

Car Show: R. Thuleen, _____, _____

Develop car show for movie customers to vote on people choice awards (customers will not know Corvair terms i.e.: early, late, open, closed, FC)

Banquet dinner: H. Tutt, _____, _____

Determine caterer and negotiate pricing and setting up & serving of banquet dinner.

Trophies / photos D. Robertson, _____, _____

Taking, printing and placing pictures in plaques for awards and commemorative photos.

Hospitality: Saturday B. Cannon, L. Thuleen, _____

Procure and set up Saturday lunch including drinks and chips. Procure and ice down drinks and set up finger foods Saturday night.

Barber Motorsport / Hotel / Hospitality Room / Banquet Room H.Tutt, _____, _____

Procure best pricing for group rate at hotel. Negotiate hospitality room rate. Determine banquet room location and negotiate price. Co-ordinate with providers as necessary.

Corvairs at Barber 2018

The Barber Committee met Friday 9/15/2017 and the following items were discussed: This year we will be changing the format for Friday. We will be going to dinner and having a car show at the Coyote Drive-In here in Leeds and viewing a “car” type movie or any of the other movies that are playing at the theater. The movie / car show, dinner and movie snacks as well as a round of mini golf is included in our registration price. Saturday will begin with photos and will be followed by parade laps at Barber. Ending the day will include a catered banquet / Awards presentation followed by hospitality get together in the hospitality room at the hotel for those with the energy to partake. While the cost this year is a little higher (\$75 / person or \$125 / family) it is our hope a reduced hotel rate will more than offset the registration increase, not to mention the increased value of the entire event. With help from all the Vulcan members we can provide more smiles per gallon and create memories of a life time.

The Barber Committee members will chair the various subcommittees and other Vulcans will complete those committees. The subcommittees will be shown in the Oil Drop and we can volunteer at the next regular meeting. Hopefully the hands of many will make the load a lot lighter.

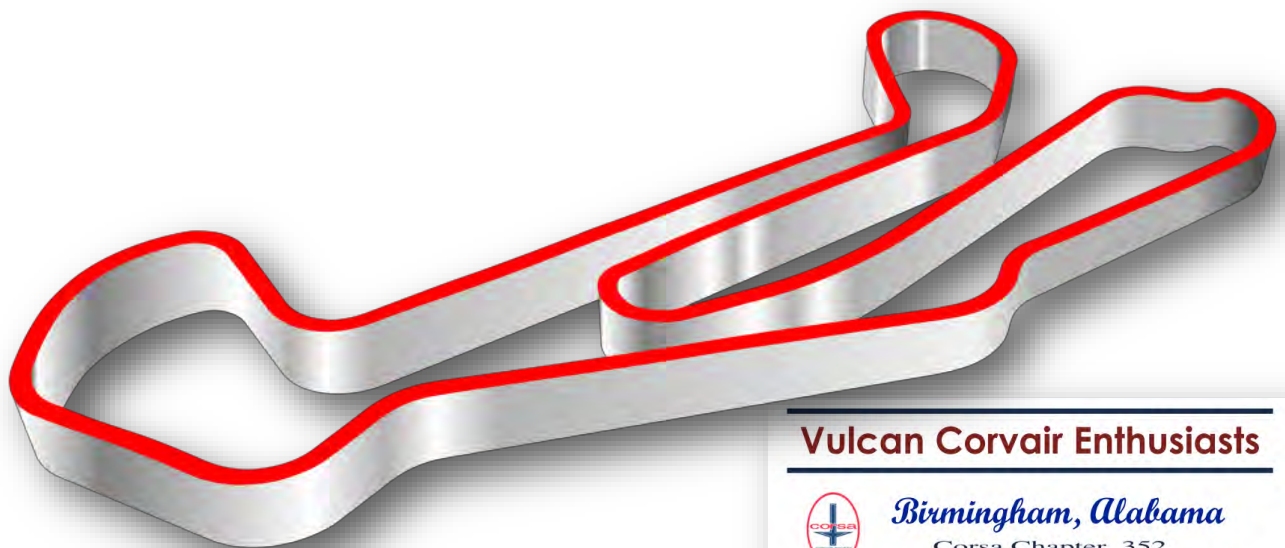

Send Oil Drop submissions to:

GTOChief@gmail.com

Office: 256-839-1905

Cell: 256-404-5998

VCE IS on Facebook...Click on the link:

[Vulcan Corvair Enthusiast FB Page](#)

CORSA is now on [Facebook](#)

NOTE: PLEASE SEND SUBMISSIONS NO LATER THAN THE 25TH OF THE MONTH.

Howard's search for a LM four door

0

The unfortunate turn of events resulting from hurricane Harvey has affected one of our own. As some of you know, Howard Tutt bought the four door that was in Richard Stolzman's barn. The car was taken to Texas where Howard's son was going to get it running and driving so that when a visit was in order, Howard would have an air conditioned Corvair to drive around in the Texas heat. Russ has been helping Howard with the rebuilding of the engine while the rest of the car was in his son's storage building in Houston.

Needless to say the flooding that so many in Houston suffered also got to the storage building and destroyed not only the four door, but also furniture and other items that his son had in the unit.

So now a freshly rebuilt motor has no where to go! Howard's current '66 Monza coupe was bought from Mr. Raffield's "Corvair Ranch Of The South" in Cookeville, TN. There also happens to be a '67 four door that is in pretty good shape available.

Howard, Russ and I recently took a day trip up to Cookeville to check it out. According to Howard, the car will be suitable for his new engine but it was just TOO HOT that day to load it up and bring it back to Leeds.



Meanwhile, the three of us enjoyed meeting with the proprietor and checking out all his cool Corvair Stuff:

A VERY low mileage '65 four door that he states that he will be buried in and another low mileage '64 coupe that is all original and is his 'daily driver'.

Ultravan #509 is there and is one of the best examples this writer has seen up close and personal.

An original 'Corvair by Chevrolet' working neon sign and lots and lots of cars and trucks in Tennessee's own Corvair Graveyard.

So as soon as the weather get a little cooler, another road trip (with the trailer) will be coming up after 'Vairs in the Valley'.

The leaves will be turning and looking good, so ya'll come and join us in the mountains of Tennessee for another Corvair adventure.



Heart of Georgia Corvairs

presents its 28th Annual
Dixie Corvair Classic
Vairs at the Fair

October 6-7 2017
In Perry, GA

Friday Night Southern Hospitality Party

Friday Swap Meet in the hotel parking lot

Saturday Parade and Display at the Georgia National Fair

Saturday Night Bar-B-Q Dinner, Raffle, 50/50.
No judging, just good fun with Corvair people.

Host Motel is the much improved Quality Inn & Suites located at
215 Margie Drive in Warner Robins, GA.
Phone 478-953-6866 for reservations.

Ask for Corvair Room rate of \$65.00 per night, or \$75.00 per
night for a suite. Rates good Oct. 5,6,7 2017
Reservations need to be made by September 1, 2017.

Come a day early and visit the Museum of Aviation
New and refurbished planes on display.

Contact:

Lillian Law (Show Chairperson) at 229-291-0567 or email at lawjandl@aol.com
163 Laurelbrook Drive
Leesburg GA 31763

The 'Corvair Tractor'

1940s-50s Allis Chalmers Model G enjoys relevance again with the debut of the CleBer LLC Oggun tractor

[Jim O'Clair](#) on Sep 18th, 2017 (Hemmings)

Six decades after the manufacture of the last Allis-Chalmers Model G small tractor in Gadsden, Alabama, a new company is beginning to produce a similarly designed tractor that could revolutionize small subsistence farming in the U.S. and abroad. CleBer LLC is now building the Oggun Iron Horse tractor in [Fyffe, Alabama](#), but the eye-opening fact that is stirring attention is that the tractor can be bought for less than \$13,000 and none of the parts are proprietary, meaning if the tractor breaks down in Chile, the owner doesn't have to wait weeks for replacement parts.

Several different engine options are available, and buyers can specify a 19-horsepower Honda or Kohler gas engine, while international customers can also specify a Kohler diesel engine. The Oggun, which has a 123-inch wheelbase and a five-gallon fuel tank, uses hydraulic steering and brakes and weighs less than 1,800 pounds.



CleBer LLC was founded by Horace Clemons and Saul Berenthal, a native of Cuba who thinks a small tractor like the Oggun would be welcome in his home country because of the affordability, size, and adaptability in the field. The width of both front and rear wheels gives the Oggun, like the Chalmers Model G, the ability to navigate narrow field rows, making it ideal for many crops including corn and ground vegetables. The front wheel track with 12-inch tires can be adjusted between 39 and



1948 Allis-Chalmers MODEL G. made in [Gadsden, Al](#)



58 inches, while the rear 24-inch wheels can be adjusted between 35 and 50 inches. The tractor offers 17 inches of ground clearance and the three-point hitch is compatible with all Category 1 attachments (front and rear cultivators, single and multiple seed planters, chisel and turning plow, grading blade, etc.), which CleBer also sells, but none of which are priced at more than \$400 per attachment.

While CleBer's main goal currently is to produce and sell these tractors to Cuban farmers, the Oggun has already been demonstrated at dozens of venues around the U.S. and in other foreign countries, and has been well received. Kudos to Mr. Clemons and Mr. Berenthal for thinking a 60-year-old tractor design can contribute to the sustainability of today's agricultural market, especially on farms where such a tractor is needed most, the small single-family homesteads that are producing just enough food for their needs and the needs of their local economy. Those are the same kind of farms America had 60 years ago when the A-C Model G proved successful.

More information on the Oggun is available on their website ThinkOggun.com.





Please consider my application for membership in the Vulcan Corvair Enthusiasts
A Chartered Chapter of CORSA (Corvair Society of America), Chapter 352

Date of Application: _____

Submit application to:
Howard Tutt
1945 Linden St.
Leeds, AL 35094

Or better yet, come to a meeting the third Friday of each month at Fullness Christian Fellowship at 2575 Columbiana Rd., Birmingham, AL 35216.

Information About You							
First Name				Last Name			
Address							
City				State			
Zip				Phone			
Email address							
Family Member(s) to be listed with the Vulcan Corvair Enthusiasts Membership							
First Name		Last Name			Birthday (mm/dd/yyyy)		
Anniversary							
Information about your Car							
Year		Color		Type		Engine CI	
Horsepower		Other					

MEMBERSHIP DUES ARE \$20.00 PER YEAR PER FAMILY, DUE JAN. 1

Initial Dues Pro-rated by Quarter (Jan-Mar: 100%, Apr-Jun: 75%, Jul-Sep: 50%, Oct-Dec: 25%)

Are you a member of Corsair? Y / N

Signature: _____

The Travelling BillBobbyery:

The escapades and ramblings of an official Corvair NUT!

This month's adventure found yours truly in our nation's capital and with an opportunity to meet a fine bunch of fellow Corvair 'nuts'. Group Corvair is the local club for The National Capital Area. They meet on every third Tuesday of the month and I was cordially invited (actually I invited myself and they accepted) to attend their 19 September meeting at Fratelli's Restaurant (The Old HoJo's) in Hyattsville, MD. The food was great and the camaraderie and fellowship was even better. I presented one of David Hausenfleck hand made Vulcan plaques to their club as a memento of the visit.



Gus & Barbara Torbert, Jim Govani, BillBobbyery, Jerry Yates, Jim & Marolyn Simpson, Bob Hall and Bob Lewis



Jerry Yates and Jim & Marolyn Simpson Corvairs



Group Corvair's president, Jim Govoni and I with the VCE plaque.

Whenever I am within a reasonable driving distance from The Corvair Ranch, I always try to make time to visit Jeff and Jeb even if I don't really need to get anything to bring back to Alabama. I was however, looking for a set of doors and headlight buckets for the current eight door project. But alas, I came back with an empty truck bed this time. You will see in the pictures that there are a couple of eight doors out on the lot but the doors were in no better condition than what we currently have. I did enjoy walking through the Corvair Graveyard once again and talking with Jeb about his wife's daily driver, an eight door Greenbrier. He has configured the doors and seats so that she can get the kids safely into their car seats by opening only one of the double doors. Pretty neat idea!



HESCO'S HOBBY SHOP

Wood Crafts by Corvair Enthusiast, David Hausenfleck
David does Jewelry Boxes, Birds of Prey, Dragons, Classic Cars,
Corvairs, Plaques and other Wood Crafts Special Order.

256-525-5087

<http://www.facebook.com/hescoshobbyshop>

hesco@att.net



FORMER VCE MEMBER, FRANK RANELLI HAS A '64 MONZA 'VERT FOR SALE;

<https://www.facebook.com/marketplace/permalink/1832922867017892>



Marketplace > Cars, Trucks & Motorcycles

1964 Corvair Monza Convertible
Birmingham, AL · 3 days ago

\$9,995 Viewed by 222 people

For sale 1964 Corvair Monza convertible. 110 HP 4 speed. New paint, new top, new interior in 2015... More

Seller information

Frank A Ranelli
Facebook member since 2008

Message Seller

ART & VICKI BOLTON HAVE A '64 COUPE FOR SALE

Monza with powerglide - very good driver with good interior & glass. It has been sitting for about 5 years and of course 'ran when parked'. Will need tires, brakes, fuel lines, etc. to get it safely back on the road.

\$3,000 OBO

CALL: 205-988-5356

THIS IS NOT THE WAY TO PLACE AN AD:

CORVAIR FOR SALE

I'm sending this message for someone who doesn't have a computer. But, he does have an old Corvair that he needs to sell because he has recently had to move into a small apartment. I think he's had the Corvair for a long time with the intention of restoring it, but is no longer able to do that due to age and poor sight. It is stored in a storage shed in Huntsville. You'll need to contact the owner for details.

If you are interested, or know someone who might be interested, please send me a name and telephone number...I will give it to him. Or, if you want to call him:

Andy Slayden

[256-316-9591](tel:256-316-9591)

FC Reproduction Standard Front Floor Mat

Thanks for purchasing this reproduction FC front floor mat. It has been cast from a used mat that required a variety of repairs. The repairs have left some surface imperfections, but these are not readily apparent when the mat is installed.

Steering column

1. Cut the seam to allow positioning the mat around the base of the steering column.

For standard transmission

2. You will need to cut the seam and remove the hole filler for the clutch pedal.

3. If you have a late style shifter (on the floor), you will need to cut a hole to fit around the square housing of the shifter assembly (see picture). You should use a single edge razor blade or sharp box cutter knife. Partially install the mat and position it correctly with the mat rolled up to the shifter to locate where the hole should be cut. Alternatively, remove the shifter assembly so that the mat can be laid flat to locate the cut out.

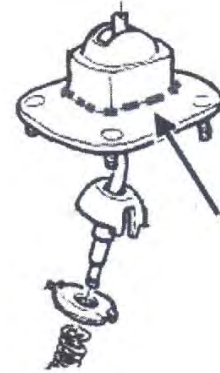

Carpet rear retainer holes

4. The mat does not have holes for mat retainers along the rear edge (see X's in diagram below) since these were not present in all the mats I've seen. You can cut holes there if appropriate for your FC.

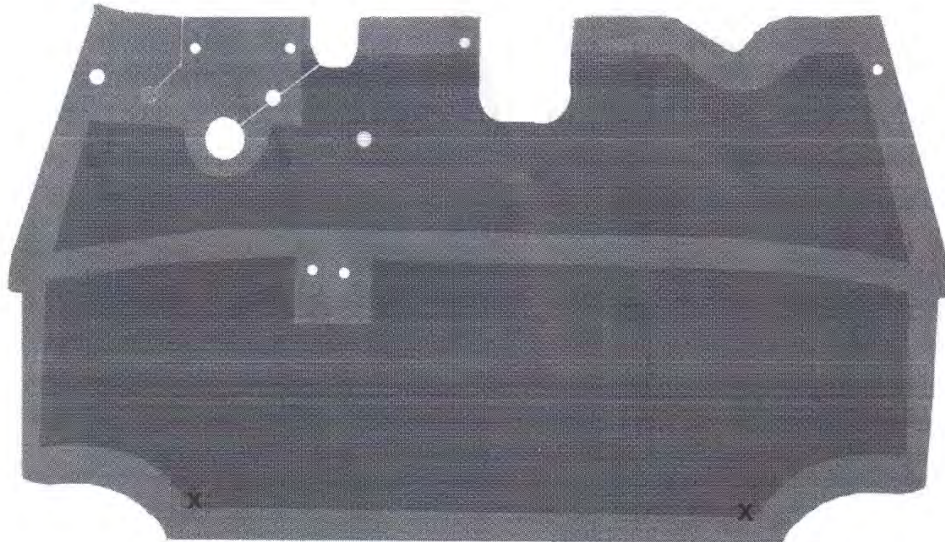

Originally below the FC front mat were a jute fiber pad (~1/4" thick), an asphalt impregnated fiber sheet (~1/8" thick), and fiber space filling blocks. Replacements for these are available from Clarks on page 282 of the catalog.

Money back guarantee – if you are dissatisfied with the mat, send it back unaltered for a full refund.

Steve Spilatro, 625 Fifth St., Marietta, OH 45750 spilatrs@marietta.edu

Our 44th Year!

Get the 2013-2018 Catalog

If you did not get the catalog in 2015 or 2016, you can get one **FREE** on your first **\$50** order during 2017. (Additional catalogs \$3 with an order)

Over 100 new repro parts in the past 3 years.

Clark's Corvair Parts®
400 Mohawk Trail
Shelburne Falls, MA 01370
(413) 625-9776 www.corvair.com



Vulcan Corvair Enthusiasts, a chapter of the Corvair Society of America, is a non-profit club dedicated to the preservation and restoration of the Corvair automobile.

VCE dues of \$20/year pay for a family membership and 12 issues of the Oil Drop Newsletter.



THE OFFICIAL NEWSLETTER OF THE VULCAN CORVAIR ENTHUSIASTS Vol 39, No. 11

In this Issue:

- * **VAIRS AT THE FAIR**
- * **CAR SHOWS**
- * **BARBER 2018**
- * **VETERANS PARADE**
- * **VCE Membership Application**
- * **Classifieds**

2017 VCE Officers

President:

John Cleveland
monzaiohn@charter.net
 205-834-3120

1st Vice President:

Richard Stolzmann
richey-rich_43@Hotmail.com
 205-467-6444

2nd Vice President (communications):

Billy Cannon
qtochief@gmail.com
 C: 256-743-0058
 H: 256-839-1905

Secretary:

Steve Daniels
steve_d_daniels@bellsouth.net
 C: 205-213-5935
 H: 205-995-9474

Treasurer:

Howard Tutt
hftutt@yahoo.com
 936-524-7611

VCE Mailing Address

Vulcan Corvaire Enthusiasts
 147 Crossbrook Dr.
 Chelsea, Al 35043

From the Prez:

As I write this one November has just begun (sorry for being so late Billy!) and thoughts are turning to cooler weather and the holidays. The show at Lineville, AL will be this coming Sunday, Nov. 5, which is also Daylight Saving Time, so remember to 'fall back' one hour Saturday night

The following week will be the Veteran's Day parade in Anniston; let's hope the weather cooperates and makes it a good parade day. We will also be getting information from some of our members about Christmas parades coming up. Last year the club was represented in Chelsea and Leeds (?). If you know about a parade in your area let one of the officers know and we'll see if we can't get some cars there.

See information in the newsletter about the date, time and location of the club's Christmas party. It should be a good time with the gift exchange we have planned. We will also take up a collection to donate to charity. One of the agenda items for our Christmas party will be the election of officers for the coming year. I have decided to step down as president and give someone else a turn at the wheel. After joining the club in 2008 I have been newsletter editor for 4 years and club president for 3 years. That represents a large percentage of the time I've been a member that I've been an officer in some capacity. I'm looking forward to being just a member again.

All positions are open for re-election though, and since I've been a member preference has been given to the incumbent if he or she wishes to remain at their post. My request to the current board is to give some thought to whether you want to remain in office and if not, let it be known at the November meeting so the membership can start considering if they would stand for election.

Also, after referring to the By-Laws, I want to make a correction about paying dues. Dues are due in January, not December, so you have another month to start saving your allowance.

With Daylight Saving Time coming we'll be

November 2017

Next Meeting:

Date: Friday, 20 October

Time: 7:00 PM

Place: Fullness Christian Center

driving our Vairs in the dark, so take the time in the next couple of weeks to make sure the lights are all working properly. Get your heater in order for the coming cooler weather and check that anti-freeze! I find a half pint under the seat works well!

Remember, clean it up, crank it up and get that Vair out there!!!!!!!

John

VCE October Meeting Minutes:

Call to Order

After dinner with more food than a football team could eat, the October 20, 2017, meeting was called to order at 7:31 PM by President John Cleveland. With 18 members in attendance, a quorum was present.

Minutes of the Previous Meeting

The Oil Drop containing the minutes of the last meeting was not available for review.

Financial Report

The financial report from Treasurer Howard Tutt was given to those in attendance. He reported that all bills are paid for the year, including the 4th

(Continued on page 2)

Happy Anniversary

Paula & Al Hilderbrand – November
Debbie & Russell Noble – November 29

Happy Birthday

Kevin Fahy – November 26
Roy Dutton – November 28

(Continued from page 1)

quarter meeting room rental for Fullness Christian Fellowship.

A motion to approve the treasurer's report was made, seconded, and passed.

Please plan to pay 2018 dues at the 2017 Christmas Party in December.

To make a dues payment, please send your check to our Treasurer:

Howard Tutt
1945 Linden St.
Leeds, AL 35094

Events

Vairs at the Fair

Several members went to Warner Robins. Overall attendance was down, and, the USAF Base Commander rode in a Mustang. Blasphemy!

Christmas Party

The Christmas party will be Friday, December 15, at Golden Corral, starting at 6:30PM. The club has reserved a private room there. The Golden Corral is behind the Cracker Barrel on Hwy 31 in Pelham at the I-65 interchange. As is customary, the club will take a collection to make a donation to charity. We'll also play Dirty Santa.

Committee Reports

Corvairs at Barber

Howard and Billy passed out info to the committee heads. More volunteers are needed.

Danny will need help with trophies. Registration is probably okay.

The budget was displayed to those in attendance. A few of the sponsors from last year have agreed to participate again.

The current plan is to not have a Saturday 'Peoples Choice' to allow time to visit the Barber Museum. An all-make, open car show Friday at the Coyote Drive-In was discussed. Insurance was an open item.

Committee	Lead	Volunteers from Tonight
Trophies	Danny Robertson	
Registration	Billy Cannon	
T-Shirts	Billy Cannon	Russell Noble
Hospitality	Judi Cannon	
Drive-In Movie	John Cleveland	
Car Show	Russ Thuleen	Marshall McDuffie

Old Business

Club Shirts

As has been previously discussed, we will purchase shirts through Lisa Garcia at:

<http://www.advertisingwithlisa.com/> More info to follow.

Membership

Russell Noble received the club's CORSA payment receipt via email. It was agreed to use Howard Tutt's name and email for CORSA. The club will continue to use Russ Thuleen's address as the physical address for the club. FYI, Steve Daniels sent the updates to CORSA on Saturday, 10/21.

The club may need to find a new meeting location for 2018. That is not definite at this time.

If anyone knows a good place to get a convertible top re-done, please contact Russell Noble.

New Business

A motion was made, seconded, and passed to play "Dirty Santa" at the Christmas party with gifts not to exceed \$20/person.

Tech Session

It was all about carbs night.

Drawings

Richard Stolzmann won a wood carving Corvaire etching from David Hausenfleck. The \$29 gas money drawing was won by Russ Thuleen.

Next Meeting

The next meeting will be November 17 at our regular location, Fullness Christian Fellowship.

Adjourn

The meeting was adjourned at 8:22 PM.



Vulcan Corvaire Enthusiasts

Birmingham, Alabama

Corsa Chapter. 352

Send Oil Drop submissions to:

GTOChief@gmail.com

Office: 256-839-1905

Cell: 256-404-5998

NOTE: PLEASE SEND SUBMISSIONS NO LATER THAN THE 25TH OF THE MONTH.

CORSA is now on [Facebook](#)

VCE IS on Facebook...Click on the link:

[Vulcan Corvaire Enthusiast FB Page](#)

Vairs at the Fair

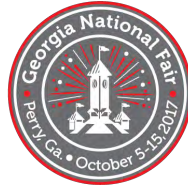

This year there was an urgent call from Lillian for convertibles. Vulcans stepped up to the plate and delivered three of the ten to accommodate the Ga. National Fair dignitaries. Richard Stolzmann drove his '65 Turbo Corsa, Russ Thuleen drove his '66 Monza and I trailered 'The Buck Mobile' ('64 Spyder that also belongs to Russ). Howard Tutt drove his '66 Monza Coupe and even had a little 'throwing' candy by the end of the parade. A good indication that the threatening weather had kept the crowd participation down. Also our Corvair attendance was



down this year but as always we had an amazing time and the weather held out just fine. Prior to Saturday's parade, VCE members continued the Friday tradition of attending the Warner Robins Air Museum and then 'buzzing' the local Chevrolet dealership. Phillip and his co-workers at FIVE STAR Chevy appreciated that we drove through and had some pictures taken. Many of the employees had never seen or even heard of our lit-



(Continued on page 4)

(Continued from page 3)

the beloved cars. FIVE STAR presented each of us with a couple of their key fobs.

Saturday included the usual visit to Joe Gleaton's club's air field and hanger where we enjoyed the great BBQ that his family members prepared. Door prizes were passed out and as is the usual case, Howard won the fifty/fifty money and graciously bought everyone's breakfast before our caravan home on Sunday.



Howard & Russ attend record number of Car Shows

The first of the month of October was of course Vairs at The Fair. The Saturday before that was the Heartland Cruisers Run to the Mill Open Car Show at Tannehill Ironworks Historical State Park September 23. The show benefits Grace House Ministries. Russ Thuleen's Turbo Charged Rumpy took home one of the top 25 trophies with overall more than 125 cars presenting.

The scheduled Bill Nichols Veterans Home Annual Car Show event unfortunately was called because of rain.

The October 21st event was at Vandiver Church of God with probably the best quality of vehicles that Howard reported ever attending and as usual, only the 2 Corvairs.

The leaves are looking good, and only a couple more weeks of opportunities so ya'll come and join us in Anniston for the Veterans Day Parade.



Bringing Back

the **Corvairs**

May 18-19 2018 to



BARBER
MOTORSPORTS PARK
BIRMINGHAM, ALABAMA

**OPEN CAR SHOW, DINNER & MOVIE FRIDAY AT THE DRIVE-IN *
MINIATURE GOLF * VINTAGE MOTORSPORTS MUSEUM ALL DAY
SATURDAY * CORVAIR PARADE LAPS ON THE TRACK * FREE T-
SHIRT * COMMEMORATIVE PHOTO * DOOR PRIZES * FIFTY-FIFTY
AND DRAWING FOR FREE BARBER WEEKEND PACKAGE (Over \$300 VALUE)**



FORT McCLELLAN
CREDIT UNION



www.CORVAIR.org



Host Hotel

**Holiday Inn Express & Suites, 811 Old Grants Mill Rd, Birmingham-Irondale
(East) Al 35210 * 205-957-0555**

**Mention CORVAIR for SPECIAL rate of \$79.00 (May 17-19)
Hotel reservations MUST be made by May 3rd or regular rates will apply**

**For more info contact: Vulcan Corvair Enthusiasts @ 936-524-7611 or 256-839-1905
Or visit: www.facebook.com/groups/VulcanCorvair/**



CCRA & VCE Veterans Parade 2017

Saturday November 11th at 2:00 PM

We will ALL meet at the old Winn Dixie Parking lot promptly at NOON for prestaging and setting up the vehicles.

President, Mike Lanphere and the bikes will be at front, Ramp-sides (with wheelchair VETS) immediately following behind with the CCRA and VCE banners on both driver and passenger sides.

All vehicles will fly the national flag on the (right) passenger side rear with the service flags flown on the (left) opposite side.

Ramp-sides:

- Billy Bruce
- James Law
- Billy Cannon

Following drivers will be in no particular order:

- Howard Tutt
- Danny Roberts
- Kevin Fahy
- Russ Thuleen



Service flags:
Still Serving USA, POW, USAF, USMC, USA, USN, USCG





Please consider my application for membership in the Vulcan Corvair Enthusiasts
 A Chartered Chapter of CORSA (Corvair Society of America), Chapter 352

Date of Application: _____

Submit application to:
 Howard Tutt
 1945 Linden St.
 Leeds, AL 35094

Or better yet, come to a meeting the third Friday of each month at Fullness Christian Fellowship at 2575 Columbiana Rd., Birmingham, AL 35216.

Information About You			
First Name		Last Name	
Address			
City		State	
Zip		Phone	
Email address			
Family Member(s) to be listed with the Vulcan Corvair Enthusiasts Membership			
First Name		Last Name	Birthday (mm/dd/yyyy)
Anniversary			
Information about your Car			
Year		Color	Type
Horsepower		Other	Engine CI

MEMBERSHIP DUES ARE \$20.00 PER YEAR PER FAMILY, DUE JAN. 1

Initial Dues Pro-rated by Quarter (Jan-Mar: 100%, Apr-Jun: 75%, Jul-Sep: 50%, Oct-Dec: 25%)

Are you a member of Corsair? Y / N

Signature: _____

HESCO'S HOBBY SHOP

Wood Crafts by Corvair Enthusiast, David Hausenfleck
David does Jewelry Boxes, Birds of Prey, Dragons, Classic Cars,
Corvairs, Plaques and other Wood Crafts Special Order.

256-525-5087

<http://www.facebook.com/hescoshobbyshop>

hesco@att.net



ART & VICKI BOLTON HAVE A '64 COUPE FOR SALE

Monza with powerglide - very good driver with good interior & glass. It has been sitting for about 5 years and of course 'ran when parked'. Will need tires, brakes, fuel lines, etc. to get it safely back on the road.

\$3,000 OBO

CALL: 205-988-5356

Clark's Corvair Parts®

Our catalog lists over 15,000 parts for your Corvair. We carry engine parts, body panels, upholstery and much more! There are 1,000's of reproduced items available, pages of technical information and lots of other helpful hints.

Check us out at www.corvair.com or call today to order a copy of our printed catalog. You will quickly see why we are the world's largest supplier of parts and all your other Corvair needs. Clark's - More than Parts!

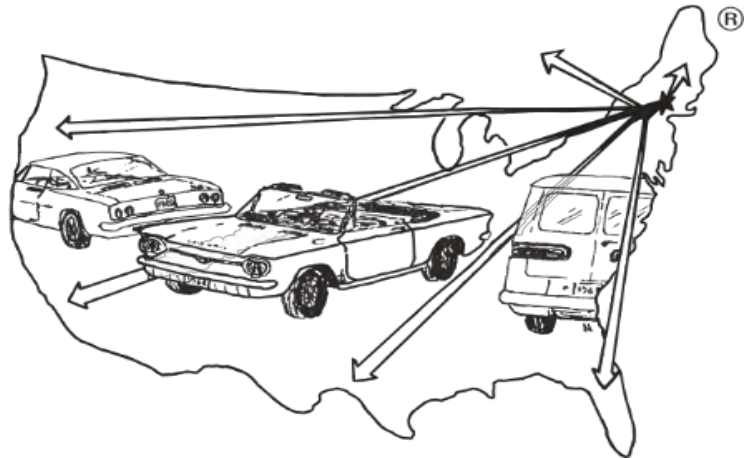

Clark's Corvair Parts® 400 Mohawk Trail, Shelburne Falls, MA 01370
(413)625-9776 www.corvair.com email: clarks@corvair.com

2018 RESTORATION PARTS CATALOG

ORIGINAL PARTS GROUP
INCORPORATED

1960-69

Corvair

WORLD'S LARGEST IN-STOCK SELECTION OF RESTORATION PARTS AND ACCESSORIES

FREE SHIPPING ON ORDERS OVER \$199
SEE INSIDE FOR COMPLETE DETAILS

ORDER ONLINE: **OPGI.COM** CALL TOLL FREE: **800.243.8355**

35 YEARS OF EXCELLENCE

Vulcan Corvair Enthusiasts, a chapter of the Corvair Society of America, is a non-profit club dedicated to the preservation and restoration of the Corvair automobile.

VCE dues of \$20/year pay for a family membership and 12 issues of the Oil Drop Newsletter.



THE OFFICIAL NEWSLETTER OF THE VULCAN CORVAIR ENTHUSIASTS Vol 39, No. 12

In this Issue:

- * **VETERANS PARADE**
- * **CHRISTMAS PARTY**
- * **CHRISTMAS 1980**
- * **BARBER 2018**
- * **VCE Membership Application**
- * **Corvair Lovers Holiday**
- * **Classifieds**

2017 VCE Officers

President:

John Cleveland
monzajohn@charter.net
 205-834-3120

1st Vice President:

Richard Stolzmann
richey-rich_43@hotmail.com
 205-467-6444

2nd Vice President (communications):

Billy Cannon
qtochief@gmail.com
 C: 256-743-0058
 H: 256-839-1905

Secretary:

Steve Daniels
steve_d_daniels@bellsouth.net
 C: 205-213-5935
 H: 205-995-9474

Treasurer:

Howard Tutt
hftutt@yahoo.com
 936-524-7611

VCE Mailing Address

Vulcan Corvair Enthusiasts
 147 Crossbrook Dr.
 Chelsea, Al 35043

From the Prez:

Denise and I hope all of you had a great Thanksgiving and at least one of your teams won a game on Saturday. We had a quiet weekend with our grandson; he's 5 so quiet is a relative term here. Several of us went Corvair treasure hunting a few weeks ago so I spent some time sorting and cataloging a large selection of carburetor parts I purchased. If you accidentally drop a screw and can't find it or flip a spring across the garage, give me a call and I'll probably have what you need.

Our club Christmas party is coming up so make sure and come. Information is located in the newsletter about the date, time, and location. This is the first time since I've been in the club where we have had a meeting 'off site' at a restaurant. I have been approached several times since I've been president about trying out this arrangement. With a large selection of food, great company, a dirty Santa gift exchange it promises to be a fun time.

Club elections will also be held; another good reason to attend. Even if you don't desire to run for an office your vote counts in selecting the officers who will run our club for the next year. The office of president and secretary will be available as Steve and I will be stepping down.

Looking forward to seeing you all at the party!

Remember, clean it up, crank it up and get that Vair out there!!!!!!!

John

VCE November Meeting Minutes:

Call to Order

After dinner the November 17, 2017, meeting was called to order at 7:29 by President John Cleveland. With 14 members in attendance, a quorum was present.

Minutes of the Previous Meeting

The Oil Drop containing the minutes of the last meeting was available for review by the members present. A motion to accept the minutes was made, seconded, and passed.

Financial Report

The financial report from Treasurer Howard

December 2017

Next Meeting:

Date: Friday, December 15

Time: 6:30 PM

Place: Golden Corral

Tutt was given to those in attendance. A motion to approve the treasurer's report was made, seconded, and passed.

John Cleveland suggested we pay the church for 1st quarter 2018 in December so we have time to make adjustments if the church wishes not to renew our arrangement to meet there.

While due in January, it's okay to pay 2018 dues at the Christmas party in December. To make a dues payment, please send your check to our Treasurer:

Howard Tutt
 1945 Linden St.
 Leeds, AL 35094

Events

Anniston Veterans Day Parade

Eight Corvairs participated in the Anniston Veterans Day Parade. They all made a photo in the Anniston paper. Joining us were our friends from GA. We had riders from the CCRA veterans group. Bill Wilkins, a 93-year old veteran from WWII rode in Shorty with Russ Thuleen driving. We enjoyed viewing the slides from the parade.

Birmingham Veterans Day Parade

John Cleveland had 2 cars, his Dad's Model A and his 'daily driver' Corvair convertible, in the Birmingham parade. John and his son Michael were behind the Daughters of the American Revolution (DAR) band and provided rides to DAR members. We enjoyed slides from the parade.

(Continued on page 2)

Happy Birthday

Paula Hilderbrand – December

Carol Keller – December 18

(Continued from page 1)

Clay County Car Show and Swap Meet

Russ, Howard, and Billy participated in the Lineville, Ala. event where \$30,000 was raised for Shriners Children Hospitals.

Christmas Party

The Christmas party will be Friday, December 15, at Golden Corral, starting at 6:30PM. The club has reserved a private room there. The Golden Corral is behind the Cracker Barrel on Hwy 31 in Pelham at the I-65 interchange. As is customary, the club will take a collection to make a donation to charity. We'll also play Dirty Santa. Please keep the gifts clean and tasteful. Please think about the organization you would like to give the donation to. That decision will be made at the party.

Committee Reports

Corvairs at Barber

Three of the Major sponsors from last year --Auto Custom Carpets (ACC), IHS Computers, and Ft. McClellan Credit Union,—have agreed to sponsor the event at the same or higher level. Coyote Drive In will also sponsor the event and let us use their logo.

The proposed design from the t-shirt committee was presented. It is Gildan Heavy Cotton Gold. The event logo is across the whole chest; the VCE logo is above it on the left. The ladies shirt won't have a pocket.

For the open car show at Coyote Drive In, people saying they are in the car show will get free admission. We pick 3 movies and the Drive In will show the one they can acquire. The club is being asked for suggestions for the movies.

The host hotel, Holiday Inn Express in Irondale, has been approved and locked in at \$79/night. You must register by 5/3 and say you're with "Corvair" to get the good rate. The hospitality room is large and free. After 25 rented nights, the club gets a free room for 2 nights; at 50 rented nights, we get a second free room. We'll give away a free room as an early sign-up prize.

Club members are being asked to stay there to be more hospitable to our out-

of-town guests.

We will request front page advertising on the Communiqué.

Old Business

There was no old business.

Membership

John Bredehoft from Helena has expressed high interest in joining the club. He and his wife have a 1960 Monza 900.

Club Officer Elections

Elections will be at the Christmas Party in December. The President and Secretary positions are open.

New Business

There was no new business.

Tech Session

We examined some trim pieces that had recently been powder coated by Danny Joe.

Drawings

John Cleveland won a wood carving VCE etching from David Hausenfleck. The \$25 gas money drawing was won by Carol Keller.

Next Meeting

The next meeting will be December 15 at Golden Corral, Pelham, during the Christmas Party.

Adjourn

The meeting was adjourned at 8:25 PM.

Date	Event	Place
12/1/2017	Christmas Parade	Rockford, AL
12/7/2017	Christmas Parade	Goodwater, AL
12/8/2017	Christmas Parade	Leeds, AL
12/16/2017	Christmas Parade	Chelsea, Al
2/23-24/2018	Corvair Lover's Holiday	Pensacola Beach, FL
4/28-29/2018	Springfest	Helen, GA



Ian Jones Corvair drawing...Click on the link: [Hot Rod Pencil](#)

VCE IS on Facebook...Click on the link: [Vulcan Corvair Enthusiast FB Page](#)

CORSA is also on [Facebook](#)



Send Oil Drop submissions to:

GTOChief@gmail.com

Office: 256-839-1905

Cell: 256-743-0082

NOTE: PLEASE SEND SUBMISSIONS NO LATER THAN THE 25TH OF THE MONTH.

Veterans groups coordinate with Corvair for November celebration

The Vulcan Corvair Enthusiasts along with Heart of Georgia Corvair teamed with MG Gerald Watson Chapter of the Chemical Corps Regimental Association (CCRA) to participate in the annual Veterans Day Parade in Anniston, Ala., Nov. 11, 2017.



Each Corvair vehicle is flying our National Colors on the passenger side rear and individual Military Service flags on the Drivers rear bumper.

Alabama, home to the oldest Veterans Day celebration – in Birmingham since 1947 – is also home to a large Veteran community as well as many Corvair lovers. Five members of Heart of Georgia Corvair came to Anniston for no less than three reasons. To once again assist their sister club with providing Rampsides and Convertibles in providing rides for Veterans, the camaraderie and connection of fellow Corvair owners and Veterans and additionally, the opportunity to take a pleasant road trip through the spectacle of fall colors .

The Anniston area is still home to an active



Lillian Law driving her husband James, 1963 Rampside.

group of CCRA members. Several of them, along with the former Chemical Corps commandant, Retired Maj.Gen. Gerald G. Watson, road in a total of eight classic Chevrolet Corvair vehicles.



Mike Gassman is displaying the USCG flag at the Calhoun County (Ala.) Parade in Anniston, Alabama .

(Continued on page 4)

(Continued from page 3)

The vehicles, all registered with the Corvair Society of America, was one of more than 55 entries in a large parade for a small community. Thousands of local residents lined Anniston's Noble Street as nearly 1,000 people marched or rode in the one-hour-long parade.



Col. Joel Warhurst, commander of Anniston Army Depot, rides in the commander's hatch of a Stryker vehicle during the Parade in Anniston

Other elements in the parade included Col. Joel Warhurst, commander of Anniston Army Depot, four high school marching bands, the Talladega (Ala.) College Marching Tornadoes Band, the Alabama Corvette Club, Veterans of the U.S. Army Women's Army Corps (WAC), and a variety of other organizations, clubs, and businesses, as well as the Calhoun County (Ala.) Sheriff Honor Guard.

"Like in years past, our committee has worked hard to organize an excellent Veterans Day Parade the entire community can be proud of as a public demonstration of our love, honor, and respect for the men and women who have served our nation as members of the Armed Forces of the United States of America," said Linda Peters, parade coordinating committee chair per-

son.

The committee selected Retired Command Sgt.Maj. Helen Johnston to be the parade Grand Marshal. She joined the WAC in 1952 and retired more than 28 years later at Fort McClellan.

For three years the Vulcan club has had to split forces in order to grant requests from parade officials on two fronts.



Russ Thuleen's shortened Loadside (Shorty), is a crowd favorite wherever it may be. This year Shorty provided parade riding comfort to Army Air Corps Veteran, Bill Wilkens who flew 30 missions in a B17 aircraft during WWII.

The Birmingham parade where Daughters of the American Revolution (DAR) have asked VCE President John Cleveland to provide Corvair convertibles for DAR dignitaries.

The Calhoun County parade committee preferred the Corvair Rampsides because of the unique ability to provide wheelchair bound veterans easy access into the bed of the truck for riding in the parade without hassle.

And finally, fellow Forward Control aficionados, we come to this authors truck which is a '62 with '64 four speed running

(Continued on page 5)

(Continued from page 4)

gear and a 140 horse power plant. It serves as the 'Parade Support' vehicle that carries all the flags, banners, mounting hardware and anything else that is needed to help this operation move as smoothly as possible. Some like to use the term 'Patina'. others tell me to keep it "just like it is" and then there are those that ask; "When ya gonna paint that thing?" I tell all these folks that right now I am having too much fun driving it and will someday, eventually, finish it as a tribute to my own Retired Navy Veteran heritage of which I am proud to say..."I Served!"



MMC (SW) Billy B. Cannon Jr. USN (Ret.)



Danny Joe Robertson ('64 Spyder)



Howard Tutt ('66 Monza)



Richard Stolzmann ('65 Corsa)



Vulcan Corvair Enthusiasts Annual Christmas Party

This year Santa's Elves, Russ and Howard, were sent out to find a suitable location for VCE's final meeting of 2017 and Christmas Party.

They settled on the closest central location feasible for all club members.



Golden Corral
101 CAHABA VALLEY PKWY E
PELHAM, AL 35124
(205) 682-0150



The Party will be **Friday, December 15, starting at 6:30 PM**. The club has reserved a private room. The restaurant is behind the Cracker Barrel on Hwy 31 in Pelham at the I-65 interchange exit 246. As is customary, the club will take a collection to make a donation to charity. We will also play 'Dirty Santa'. Please keep the gifts clean and tasteful and don't spend over \$20. Please think about the organization you would like to give the donation to. That decision will be made at the party.

Here is a Satellite view of the location:

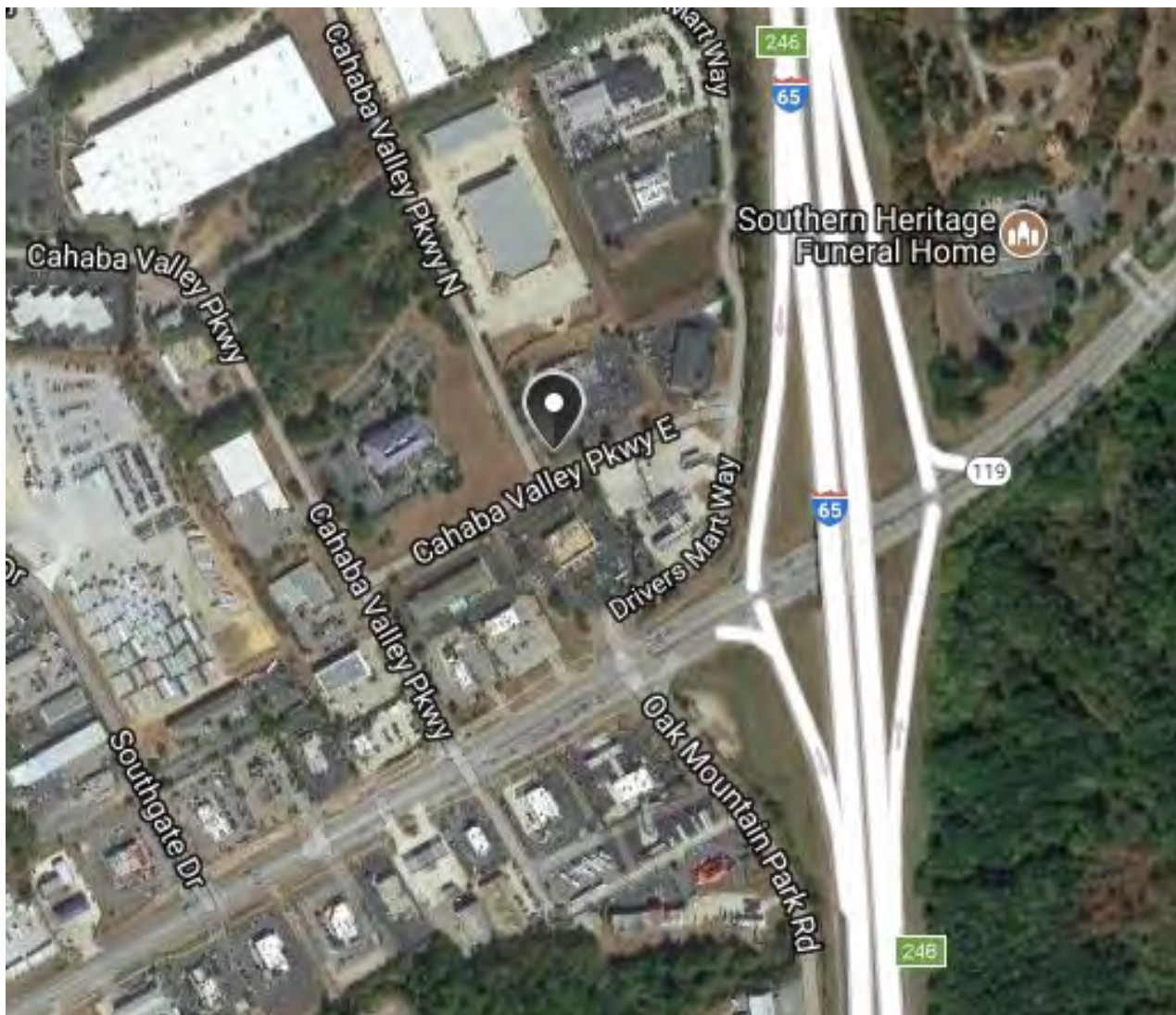



Vulcan Corvair Enthusiasts

P. O. Box 5771 • Birmingham, Alabama 35209

December 3, 1980

Please Address Reply To:

CHRISTMAS PARTY

All members and their families
are cordially invited to attend
The Annual Christmas Party
at the

Sheraton Downtown
300 10th Ave. No. Birmingham
Wednesday, December 10, 1980
Social Hour at 7:00 P.M.
Dinner at 8:00 P.M.

Come early and enjoy the fellowship with friends before dinner. Set-ups will be furnished but you will have to bring anything else you want for the happy hour. There will be an exchange of gag gifts so bring one if you wish to participate.

-MENU .-

Steak and Accompaniments

\$9.50 per person

Reservations; Contact Bobbie Floyd 923-7968 at your earliest convenience. She has to give the Sheraton a count.

1981 OFFICERS

President-----John Hathaway
Activities Vice President-----Gil Langswager
Membership Vice President-----Bill Thurman
Secretary-----Chris Rothe
Treasurer-----Terry Wilkins
News Letter Editor-----Dan Brock

Corvairs

on the track

BARBER

MOTORSPORTS PARK
BIRMINGHAM, ALABAMA

May 18-19 2018



**OPEN CAR SHOW, DINNER & MOVIE FRIDAY AT THE DRIVE-IN *
MINIATURE GOLF * VINTAGE MOTORSPORTS MUSEUM ALL DAY
SATURDAY * CORVAIR PARADE LAPS ON THE TRACK * FREE T-
SHIRT * COMMEMORATIVE PHOTO * DOOR PRIZES * FIFTY-FIFTY
AND DRAWING FOR FREE BARBER WEEKEND PACKAGE (Over \$300 VALUE)**

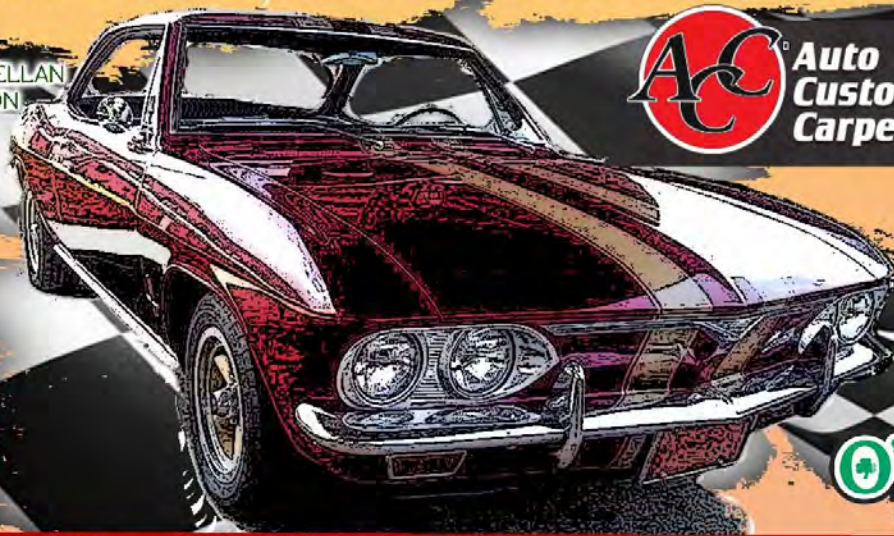

Host Hotel

**Holiday Inn Express & Suites, 811 Old Grants Mill Rd, Birmingham-Irondale
(East) Al 35210 * 205-957-0555**

**Mention CORVAIR for SPECIAL rate of \$79.00 (May 17-19)
Hotel reservations MUST be made by May 3rd or regular rates will apply**

**For more info contact: Vulcan Corvair Enthusiasts @ 936-524-7611 or 256-839-1905
Or visit: www.facebook.com/groups/VulcanCorvair/**



Please consider my application for membership in the Vulcan Corvair Enthusiasts
 A Chartered Chapter of CORSA (Corvair Society of America), Chapter 352

Date of Application: _____

Submit application to:
 Howard Tutt
 1945 Linden St.
 Leeds, AL 35094

Or better yet, come to a meeting the third Friday of each month at Fullness Christian Fellowship at 2575 Columbiana Rd., Birmingham, AL 35216.

Information About You							
First Name				Last Name			
Address							
City				State			
Zip				Phone			
Email address							
Family Member(s) to be listed with the Vulcan Corvair Enthusiasts Membership							
First Name		Last Name			Birthday (mm/dd/yyyy)		
Anniversary							
Information about your Car							
Year		Color		Type		Engine CI	
Horsepower		Other					

MEMBERSHIP DUES ARE \$20.00 PER YEAR PER FAMILY, DUE JAN. 1

Initial Dues Pro-rated by Quarter (Jan-Mar: 100%, Apr-Jun: 75%, Jul-Sep: 50%, Oct-Dec: 25%)

Are you a member of Corsair? Y / N

Signature: _____

**The 33rd Annual
Corvair Lovers Holiday & Car Show
February 23 & 24, 2018**

Host Hotel: Days Inn Pensacola Beachfront

www.daysinn.com/hotel/21564

16 Via De Luna Drive

Pensacola Beach, FL 32561

850-934-3300 or 800-934-3301

Mention the "Corvair" for the special rate

\$79 Inland, \$89 Sound Side (Parking Lot) and \$109 Gulf Front

**Pet Friendly: Paradise Inn
21 Via De Luna Drive
Pensacola Beach, FL 32561
850-932-2319**

**Pensacola Beach RV Resort
17 Via De Luna Drive
Pensacola Beach, FL 32561
850-932-4670**

Proud Sponsor of Dog and Cat Animal Rescue

Hospitality Dinner Friday Night! Out to Dinner Saturday Night! Door Prizes! 50/50!

Vendors welcome outside and must register for the show! Peoples Choice "Top Three!"

Awards Given Out on Saturday Afternoon! Special awards: Best of Show!

Sarah White Ladies Choice Award! Longest Distance! Hard Luck!

Registration begins at 4:00 pm on Friday Afternoon!

(Schedule of Events and trophies are subject to change)

For information contact June Lindsay at 5670 San Vair Street, Milton FL or Call 994-2161.

HESCO'S HOBBY SHOP

Wood Crafts by Corvair Enthusiast, David Hausenfleck
David does Jewelry Boxes, Birds of Prey, Dragons, Classic Cars,
Corvairs, Plaques and other Wood Crafts Special Order.

256-525-5087

<http://www.facebook.com/hescoshobbyshop>

hesco@att.net



ART & VICKI BOLTON HAVE A '64 COUPE FOR SALE

Monza with powerglide - very good driver with good interior & glass. It has been sitting for about 5 years and of course 'ran when parked'. Will need tires, brakes, fuel lines, etc. to get it safely back on the road.

\$3,000 OBO

CALL: 205-988-5356

Clark's Corvair Parts®

Our catalog lists over 15,000 parts for your Corvair. We carry engine parts, body panels, upholstery and much more! There are 1,000's of reproduced items available, pages of technical information and lots of other helpful hints.

Check us out at www.corvair.com or call today to order a copy of our printed catalog. You will quickly see why we are the world's largest supplier of parts and all your other Corvair needs. Clark's - More than Parts!

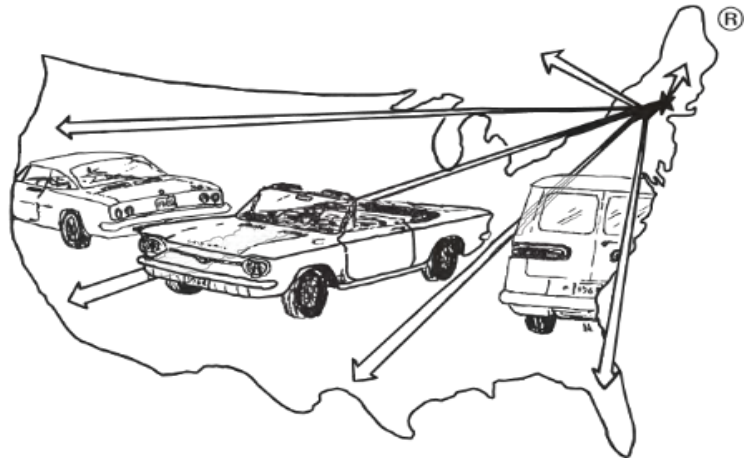

Clark's Corvair Parts® 400 Mohawk Trail, Shelburne Falls, MA 01370
(413)625-9776 www.corvair.com email: clarks@corvair.com

Vulcan Corvair Enthusiasts, a chapter of the Corvair Society of America, is a non-profit club dedicated to the preservation and restoration of the Corvair automobile.

VCE dues of \$20/year pay for a family membership and 12 issues of the Oil Drop Newsletter.