

Swagelok VCR  
 Gland: 6LV-4-VCR-3-4TB7  
 Nut: SS-4-HVCR-4SR

Lesker  
 2.75 CF Blank  
 F0275X000N

SECTION A-A  
 SCALE 3 : 1

DETAIL B  
 SCALE 6 : 1

$.313 \pm 005$

TIG weld, fillerless  
 Weld bead not to  
 extend above surface

Drill, tap #10-32  
 full length thread

TIG weld, fillerless  
 Weld bead not to  
 extend above surface

$.375 \pm 005$

$.438 \pm 005$

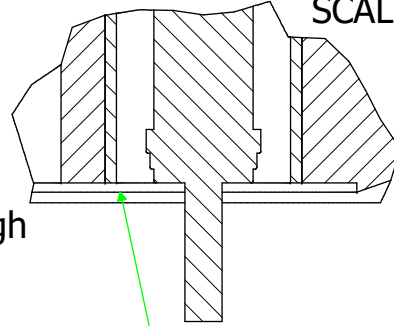
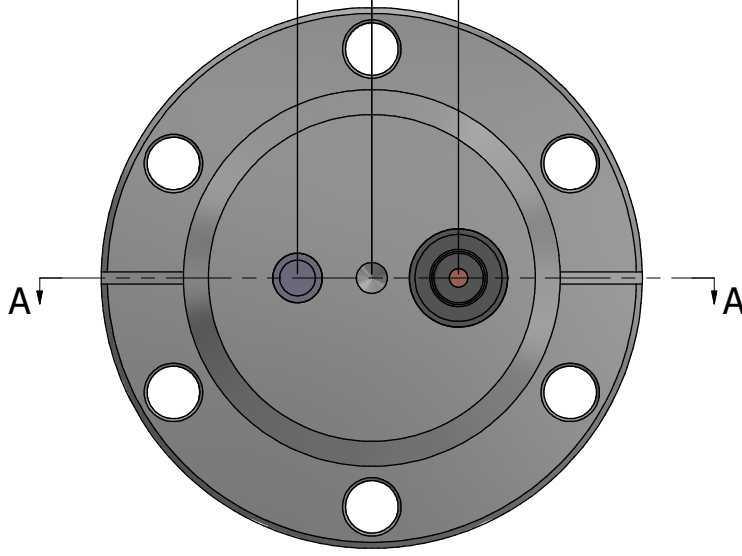
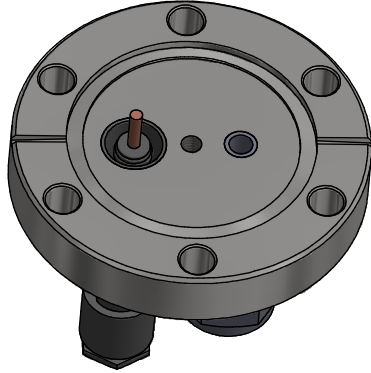
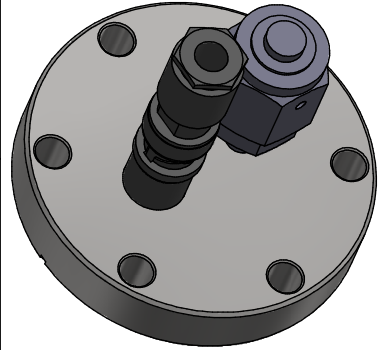

DRAWN	seltzman	3/28/2017		
CHECKED			TITLE	
QA				
MFG				
APPROVED				
	SIZE	DWG NO	REV	
	D	baseplate_custom_offset		
	SCALE	3 : 1	SHEET 1 OF 1	