



United States Phone: (715) 953-2417

Europe Phone: (44) 1225 700 476

Australia Phone: (61) 263 727 203

# POWER DOSER™

2 ml, 10 ml, 30 ml & 60 ml

## Instruction Manual



## **INTRODUCTION**

Power Doser™ dispensers are a group of instruments used for delivery of medicants using compressed carbon dioxide from a tank, air from a compressor or other compressed gasses. The system is designed for use with large numbers of animals, providing high repeatability of dosage levels.

In the past, medicant delivery was performed using manual draw-off dosing instruments. With large numbers of animals to be treated with antiparasitics, vaccines and other drug products, hand fatigue is a problem. The fatigue can cause the operator to under-dose the prescribed volume or cause uneven delivery of medicant to the delivery site in the case of topicals with a hand-operated instrument. The potential for the operator's personal injury via Carpal Tunnel Syndrome is apparent due to the repetitive motion of dosing and force exerted to deliver medicant which can vary in viscosity and volume.

Using the Power Doser™, medicants are delivered by merely pressing the trigger button. The Power Doser™ actuates, delivering the product and reloading the barrel with medicant in seconds. This same operation with a manual instrument could take 3-5 times longer on initial delivery. As time passes and fatigue sets in, the delivery can be slowed even further, increasing the potential for improper volume of medicant to be delivered.

Another advantage of the Power Doser™ is the repeatability of medicant delivered once the dosage is set and proven. No manual delivery system can deliver the same volume at dose one and continue to deliver the same amount at dose one thousand without interruption. Immediate delivery upon refilling of the barrel is the key to rapid animal processing. No manual system can deliver the volume consistently in the time frame the Power Doser™ supplies.

Regarding the power source, compressors and generators are available at most farm operations around the world that are involved with intensive animal raising. Remarkably, the Power Doser™ functions readily at a consistent 80 pounds per square inch (PSI). Lower settings down to 40 PSI will only cause the system to actuate and fill more slowly, but still function more dependably than manual systems. Simple pressure settings regulate the speed at which the operator wishes to dispense the product.

Since most livestock processing is completed via races and chutes, the Power Doser™ lends itself to systematic processing techniques. A CO<sub>2</sub> kit is available for mobility if needed.

## **CONNECTION TO AIR POWER SOURCE AND MEDICANTS**

Connection is made using a spring-loaded quick connect/disconnect coupling onto the handle coupler. A length of hose is required between the Power Doser™ and the reservoir tank or CO<sub>2</sub> cylinder.

- More mobility requires more hose.
- Stationary position with coiled tubing may be effective.
- Liquid Petroleum Gas use requires specialized components approved for this use. Please contact Genesis Instruments for this information.

Connect medicant utilizing specific draw-off cap and length of hose correlating to mobility desired. The draw-off system is directly affected by medicant being used.

- Topicals and orals are generally in pails or large drums so threaded vented caps are required.
- Injectable and anthelmintics are generally in stoppered bottles which will require draw-off tube (DOT):
  - Vented spiked DOT's are used with rigid bottles.
  - Non-vented spiked DOT's are used with flexible pouches and flexi-paks.
  - Vented spiked DOT's have a piercing tip that penetrates the stopper of a bottle.
  - Both vented and non-vented DOT's are sold as accessory items for the instrument.

Bleed line by rapid actuation of Power Doser™:

- Creates the vacuum to draw medicant up the tube and into the barrel.
- Set desired dosage volume.
- Empty air in barrel by actuating system attached to medicant so barrel fills 100% with medicant.

## **VERIFICATION OF DOSAGE DELIVERY**

Dispense one dose into a graduated cylinder. If the correct volume dispenses, actuate a second time to re-verify. If the correct volume dispenses, the system is ready for use.

If volume dispensed is incorrect:

- Adjust nut up or down as needed to correct inaccuracy.
- Repeat delivery into graduated cylinder.
- If correct, proceed.

Delivery and repeatability are critically important.

## DELIVERY METHODS / NOZZLES

Three major types:

### **INJECTABLE**

- Use of needles for intramuscular and subcutaneous injection.
- Needle is placed onto the luer lock tip.
- Made in either nylon or stainless steel.

### **TOPICAL**

- Volume is sprayed onto animal's back.
- Tips are custom manufactured to fit regiments of the client.

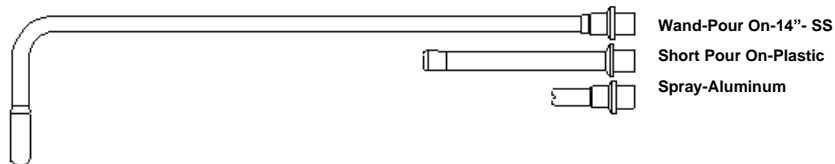

### **ORAL**

- Volume is delivered into the animal via the mouth.
- Custom manufacturing of nozzle with or without valves.

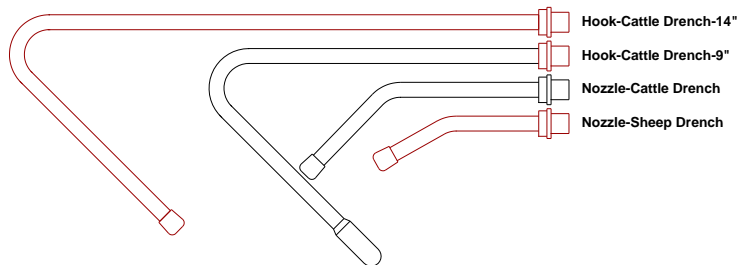

All delivery nozzles have a specific base that is machined or molded to critical dimensions. The base of the nozzle interfaces intimately with the interior of the barrel valve assembly contour. The valve assembly is retained inside the nozzle's base which forces the ball valve against the barrel outlet channel.

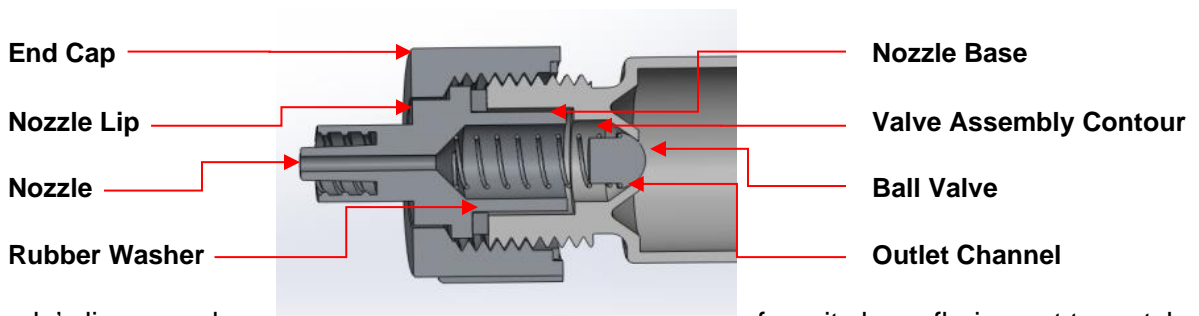

The nozzle's lip expands from its base flaring out to match with the barrel's valve assembly contour and uses a rubber washer to create a tight seal between the nozzle and barrel. The end cap surrounds the nozzle's lip and threads directly onto the outside diameter of the barrel's valve assembly contour.

- Nozzle is secured.
- Seal is absolute once secured.

## **TROUBLESHOOTING TIPS**

The following tips for correcting simple problems will reference component part descriptions that can be cross-referenced with the enclosed Power Doser™ drawings which identify all components.

**Problem #1:** Barrel will not fill with liquid.

**Possible solutions:**

- Ensure the Outlet Check is correctly in place and not blocked. Also check that the valve is not worn and needs replacing.
- Ensure the Inlet Check Ball is correctly in place and not blocked.
- Ensure the liquid hose from the container to the gun is not crimped or bent, preventing flow of liquid.
- Check that the liquid hose end is completely submerged into the liquid so that it does not draw air into the hose.
- Check that the Piston O-Ring 1" x 1 ¼" is lubricated. Replace if worn or cracked.
- Check that the Spring Piston is functioning.

**Problem #2:** Barrel partially fills with air.

**Possible solutions:**

- Ensure the Outlet Check is correctly in place and not blocked. Also check that the valve is not worn and needs replacing.
- Ensure the Inlet Check Ball is correctly in place and not blocked.
- Check that the Piston O-Ring 1" x 1 ¼" is lubricated. Replace if worn or cracked.
- Check that the liquid hose end is completely submerged into the liquid so that it does not draw air into the hose.

**Problem #3:** Liquid dispenses too slowly.

**Possible solutions:**

- Increase the PSI setting on the regulator, maximum of 80 PSI.
- Lubricate the Piston O-Ring 1" x 1 ¼". Replace if worn or cracked.

**Problem #4:** Instrument is not dispensing the correct dose.

**Possible solutions:**

- Set the front of the plunger with the calibration marks on the barrel and verify with a graduated cylinder for accurate dose setting.
- Ensure the Inlet Valve assembly is correctly in place and not blocked.
- Ensure the Inlet Valve assembly is not worn, cracked or chipped. Replace if problem persists.

**Note:** "Inlet Valve assembly" consists of Spring .010 Diameter, Inlet Check Ball and Inlet Fitting.



## CONTACT INFORMATION

Country	Phone	Email and Website
<b>United States</b>	<b>(715) 953-2417</b>	<b>sales@genesisinstruments.com</b>
		<b>www.genesisinstruments.com</b>
<b>Europe</b>	<b>(44) 1225 700 476</b>	<b>sales@genesisindustries.co.uk</b>
		<b>www.genesisindustriesinc.com</b>
<b>Australia</b>	<b>(61) 263 727 203</b>	<b>genesis@genind.com.au</b>
		<b>www.genesisindustries.com.au</b>