



Cavagna group

Advanced solutions for gas control



LPG Bulk Storage and Truck Equipment





cavagna group

Advanced solutions for gas control

Divisions



LPG REGULATORS



LPG VALVES AND TANK EQUIPMENT



HIGH PRESSURE EQUIPMENT



NATURAL GAS AND METERING DIVISION



ALTERNATIVE FUEL SYSTEMS



ENGINEERING AND SERVICES

reca
ITALY



omeca
ITALY



omeca
ITALY



reca
ITALY



omeca
ITALY



cavimatic
ITALY



Kosangas
PORTUGAL



cavagna group asia
THAILAND



pergola
ITALY



MESURA
FRANCE



bigas
ITALY



cavagna group engineering
ITALY



zhongshan cavagna
CHINA



Kosan
INTERNATIONAL
ITALY



MESURA
TUNISIA



CONGRIF
VENEZUELA



MESURA Nimal INDIA
Gas Controls



n.p. ITALY



cemco kosangas
CHILE



cavagna group sudamericana ltda
COLOMBIA



TABLE OF CONTENTS

LPG Bulk Storage and Truck Equipment

Threaded Internal Valve	4
Flanged Internal Valve 3"	7
Flanged Internal Valve 4"	8
Flanged Internal Valve	9
Threaded and Flanged Internal Valve Accessories	10
Rotary Cams Actuators	12
Latch/Remote Release Mechanisms	14
Accu-Max Float Gauges	15
Rotary Gauge System	16
Excess Flow Valves for Liquid or Vapor	17
Excess Flow Valves for Liquid or Vapor withdrawal	17
Flanged Excess Flow Valves	18
Flanged Back Check Valves	18
Wafer Excess Flow Valves	18
Back Pressure Valves for Container or Line Applications	19
LPG Filling Head for Tank Filler Valves Manually Operated	19
Hose end Swivel Connectors	20
I - Empty EZ Unloading adapter for Container Evacuation	20
Quick Acting Dispensing Valves	21
Hose End Fill Check Adapters	21
High Flow Globe & Angle Valves	22
Full Internal Relief Valves	23
Flanged Full Internal Relief Valves	23
Combination Valves	24
Container Thermometers	24
Liquid Transfer Valves & Adapters	25
ACME Adapters	26
Filler and Vapor	26
ACME Caps	26
ACME Adapters	26
Manifold for Safety Relief Valves 2 Places For Lpg Tanks	27
External Pressure Relief Valves	28
Hydrostatic Pressure Relief Valves	29
Fixed Liquid Level Gauges	29
Liquid Withdrawal & Transfer Valves	30
Self-Cleaning Y-Strainers	31
Pull-away Couplings	31
Heavy Duty Acme Spanner Wrench	31
Extractable Level Rod For Tanks	32
Thermodensimeter with Aerometer	32

Ball Valves and Actuators

Ball Valves Construction Details	34
Pneumatic Actuator	35
Spring retur pneumatic actuator "SR" type	36
Carbon Steel Wafer	37
Stainless Steel Wafer	37
Wafer Serie Construction Details	38
PN 16-40 Wafer Serie Spring Return Pneumatic Actuator	40
ANSI 150-300 Wafer Serie Spring Return Pneumatic Actuator	40
Carbon Steel Split Wafer	41
Stainless Steel Split Wafer	41
Split Wafer Series Construction Details	42
Carbon Steel Split Body	43
Stainless Steel Split Body	43
Split Body Series Construction Details	44
PN 16-40 Split Body Series Spring Return Pneumatic Actuator	47
ANSI 150-300 Split Body Series Spring Return Pneumatic Actuator	47
Certifications	48
Warranty	49

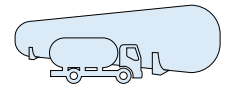

Threaded Internal Valves

These valves, designed as primary shut-offs to control product discharge in LP-Gas service, are predominantly used in the liquid and vapour openings of bobtail and other transport vehicles. All valves satisfy the requirements of NFPA 58 and can also be used in stationary storage tank applications. All Cavagna internal valves have a robust, one piece body design and an incorporated excess flow function. Each valve has a weak section that allows the pump or piping to “shear” in the event of an accident, thereby leaving the valve mechanism intact. Cavagna threaded valves are compact and can be operated either manually or remotely via cable or pneumatic control. Valves contain spring-loaded, PTFE packing providing excellent leakage protection and the standard disc material provided is Nitrile.



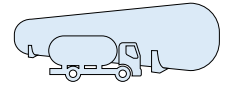

Threaded Internal Valves



Part Number		Material	Inlet Connection	Outlet Connection	Closing Flow GPM Propane		LPG Vapour Capacity (SCFH/Propane)		Closing Flow GPM Ammonia NH ₃ + LPG
One Way	Two ways				Half Coupling	Full Coupling	25 PSIG	100 PSIG	
6902900101	-----	steel	1-1/4" M NPT	1-1/4" F NPT	30	-----	5.800	9.100	27
6902900102	-----	steel	1-1/4" M NPT	1-1/4" F NPT	50	35	7.650	12.900	45
6902900103	-----	steel	1-1/4" M NPT	1-1/4" F NPT	80	65	10.950	18.800	72
6902900104	6902900130	steel	2" M NPT	2" F NPT	100	60	21.550	36.800	90
6902900105	6902900131	steel	2" M NPT	2" F NPT	150	90	33.600	57.200	135
6902900106	6902900132	steel	2" M NPT	2" F NPT	250	130	-----	-----	225
6902900107	6902900112	steel	3" M NPT	3" F NPT	150	100	28.600	48.700	135
6902900108	6902900113	steel	3" M NPT	3" F NPT	200	125	43.500	73.900	180
6902900109	6902900114	steel	3" M NPT	3" F NPT	250	165	51.500	87.600	225
6902900110	6902900115	steel	3" M NPT	3" F NPT	400	235	80.100	139.000	360
6902900111	6902900116	steel	3" M NPT	3" F NPT	500	325	-----	-----	450



Part Number		Material	Inlet Connection	Outlet Connection	Closing Flow GPM Propane		LPG Vapour Capacity (SCFH/Propane)	
One Way	Two ways				Half Coupling	Full Coupling	25 PSIG	100 PSIG
6902900150	-----	steel	1-1/4" M NPT	1-1/4" F NPT	30	-----	5.800	9.100
6902900151	-----	steel	1-1/4" M NPT	1-1/4" F NPT	50	35	7.650	12.900
6902900152	-----	steel	1-1/4" M NPT	1-1/4" F NPT	80	65	10.950	18.800
6902900147	-----	steel	1-1/2" M NPT	1-1/2" F NPT	30	-----	5.800	9.100
6902900148	-----	steel	1-1/2" M NPT	1-1/2" F NPT	50	35	7.650	12.900
6902900149	-----	steel	1-1/2" M NPT	1-1/2" F NPT	80	65	10.950	18.800
6902900153	6902900176	steel	2" M NPT	2" F NPT	100	60	21.550	36.800
6902900154	6902900177	steel	2" M NPT	2" F NPT	150	90	33.600	57.200
6902900155	6902900178	steel	2" M NPT	2" F NPT	250	130	-----	-----
6902900156	6902900161	steel	3" M NPT	3" F NPT	150	100	28.600	48.700
6902900157	6902900162	steel	3" M NPT	3" F NPT	200	125	43.500	73.900
6902900158	6902900163	steel	3" M NPT	3" F NPT	250	165	51.500	87.600
6902900159	6902900164	steel	3" M NPT	3" F NPT	400	235	80.100	139.000
6902900160	6902900165	steel	3" M NPT	3" F NPT	500	325	-----	-----

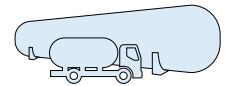

Threaded Internal Valves

1-1/2" ONE WAY

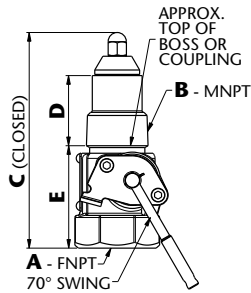

1-1/4" ONE WAY

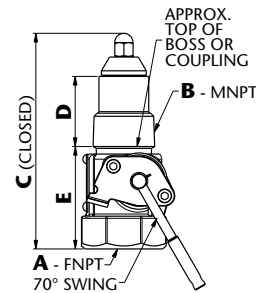

2" ONE WAY

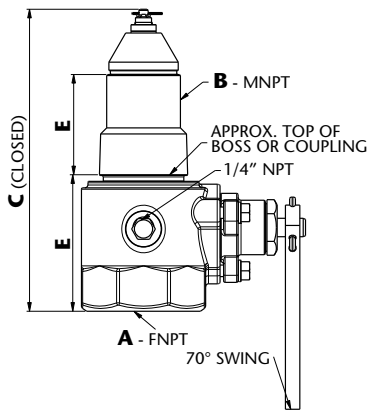

2" TWO WAY

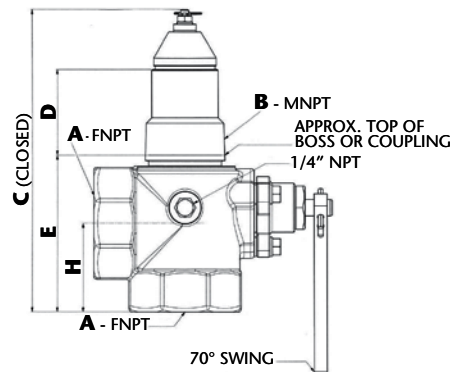

3" ONE WAY

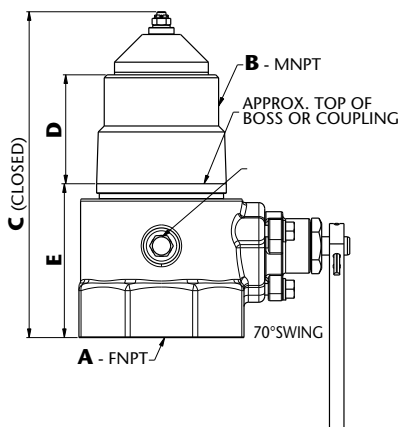

3" TWO WAY

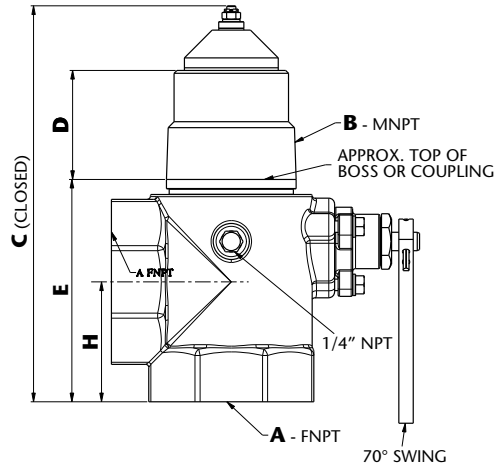

Threaded Valves specification:
 Pressure Rating: 400 PSI (27.58 bar) WOG
 Temperature: Up to 150°F (66°C)
 Body: Hot forged steel
 Packing: PTFE
 Seat disk: Synthetic rubber
 Stub, Shaft & Stem: stainless steel

DIMENSIONS					
A	B	C	D	E	H
1-1/4" NPT	1-1/4" NPT	5,90" (150 mm)	1,86" (47 mm)	2,88" (73 mm)	-----
1-1/2" NPT	1-1/2" NPT	5,90" (150 mm)	1,86" (47 mm)	2,88" (73 mm)	-----
2" NPT	2" NPT	8,26" (210 mm)	2,40" (61 mm)	4,05" (103 mm)	-----
3" NPT	3" NPT	8,85" (225 mm) ONE WAY	2,56" (65 mm) ONE WAY AND TWO WAY	4,54" (115,3 mm) ONE WAY	3,26" (83 mm)
		10,82" (275 mm) TWO WAY		6,50" (165,3 mm) TWO WAY	

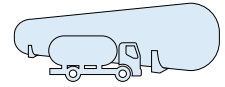

Flanged Internal Valve 3"



Cavagna flanged valves, equipped with a built-in excess flow valve to prevent uncontrolled product release, are perfect for mounting a pump or other similar piping connections. Mounting bolts weakened section, provided, allow the pump or piping to "shear" in the event of an accident, thereby leaving the valve intact.

Cavagna flanged valves have a protection filter to avoid pump contamination from dirt and particles, easily removable when the valve is installed on the filling piping line. Cavagna flanged valves contain PTFE packing providing excellent leakage protection and the standard disc material provided is Nitrile, they can be operated manually or remotely via cable or pneumatic control.



Part Number		Material	Inlet Connection	Outlet Connection	Closing Flow GPM Propane	LPG Vapor Capacity (SCFH/Propane)		Closing Flow GPM Ammonia NH ₃ + LPG
Single	Double					25 PSIG Inlet	100 PSIG Inlet	
6902900117	6902900122	steel	3"300lb ANSI RF Modified (4 7/8" dia bore)	3" 300 lb. ANSI RF	150	25.100	42.700	135
6902900118	6902900123	steel	3"300lb ANSI RF Modified (4 7/8" dia bore)	3" 300 lb. ANSI RF	200	36.900	62.800	180
6902900119	6902900124	steel	3"300lb ANSI RF Modified (4 7/8" dia bore)	3" 300 lb. ANSI RF	250	42.200	71.800	225
6902900120	6902900125	steel	3"300lb ANSI RF Modified (4 7/8" dia bore)	3" 300 lb. ANSI RF	400	59.400	100.900	360
6902900121	6902900126	steel	3"300lb ANSI RF Modified (4 7/8" dia bore)	3" 300 lb. ANSI RF	500	-----	-----	450



Part Number		Material	Inlet Connection	Outlet Connection	Closing Flow GPM Propane	LPG Vapor Capacity (SCFH/Propane)	
Single	Double					25 PSIG Inlet	100 PSIG Inlet
6902900166	6902900171	steel	3"300lb ANSI RF Modified (4 7/8" dia bore)	3" 300 lb. ANSI RF	150	25.100	42.700
6902900167	6902900172	steel	3"300lb ANSI RF Modified (4 7/8" dia bore)	3" 300 lb. ANSI RF	200	36.900	62.800
6902900168	6902900173	steel	3"300lb ANSI RF Modified (4 7/8" dia bore)	3" 300 lb. ANSI RF	250	42.200	71.800
6902900169	6902900174	steel	3"300lb ANSI RF Modified (4 7/8" dia bore)	3" 300 lb. ANSI RF	400	59.400	100.900
6902900170	6902900175	steel	3"300lb ANSI RF Modified (4 7/8" dia bore)	3" 300 lb. ANSI RF	500	-----	-----

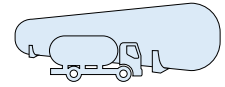

Flanged Internal Valve 4"



Cavagna flanged valves, equipped with a built-in excess flow valve to prevent uncontrolled product release, are perfect for mounting a pump or other similar piping connections. Mounting bolts weakened section, provided, allow the pump or piping to “shear” in the event of an accident, thereby leaving the valve intact. Cavagna flanged valves have a protection filter to avoid pump contamination from dirt and particles, easily removable when the valve is installed on the filling piping line. Cavagna flanged valves contain PTFE packing providing excellent leakage protection and the standard disc material provided is Nitrile, they can be operated manually or remotely via cable or pneumatic control.



Part Number	Material	Inlet Connection	Outlet Connection	Closing Flow GPM Propane
6902900141	steel	4"300lb ANSI RF Modified (4 7/8" dia bore)	4" 300 lb. ANSI RF	340
6902900142	steel	4"300lb ANSI RF Modified (4 7/8" dia bore)	4" 300 lb. ANSI RF	440
6902900143	steel	4"300lb ANSI RF Modified (4 7/8" dia bore)	4" 300 lb. ANSI RF	600
6902900144	steel	4"300lb ANSI RF Modified (4 7/8" dia bore)	4" 300 lb. ANSI RF	800
6902900145	steel	4"300lb ANSI RF Modified (4 7/8" dia bore)	4" 300 lb. ANSI RF	1.000



Part Number	Material	Inlet Connection	Outlet Connection	Closing Flow GPM Propane
6902900181	steel	4"300lb ANSI RF Modified (4 7/8" dia bore)	4" 300 lb. ANSI RF	340
6902900182	steel	4"300lb ANSI RF Modified (4 7/8" dia bore)	4" 300 lb. ANSI RF	440
6902900183	steel	4"300lb ANSI RF Modified (4 7/8" dia bore)	4" 300 lb. ANSI RF	600
6902900184	steel	4"300lb ANSI RF Modified (4 7/8" dia bore)	4" 300 lb. ANSI RF	800
6902900185	steel	4"300lb ANSI RF Modified (4 7/8" dia bore)	4" 300 lb. ANSI RF	1.000

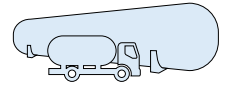

Flanged Internal Valve

3" Single/Double Flanged Internal Valve

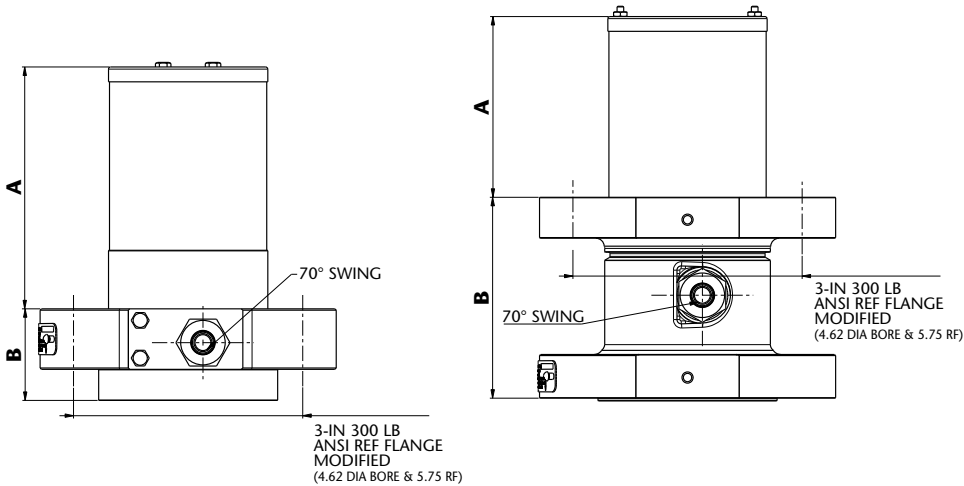

Flanged Valves specification:
 Pressure Rating: 400 PSI (27.58 bar) WOG
 Temperature: Up to 150°F (66°C)
 Body: hot forged steel
 Packing: PTFE
 Seat disk: Synthetic rubber
 Stub, Shaft & Stem: stainless steel
 Gaskets: Non asbestos spiral wound graphite

Part Number		DIMENSIONS		DIMENSIONS	
		A	B	A	B
Single	Double	Single	Single	Double	Double
6902900117	6902900122	6,75" (171 mm)	2,56" (65 mm)	5,33" (133 mm)	5,62" (143 mm)
6902900118	6902900123				
6902900119	6902900124				
6902900120	6902900125				
6902900121	6902900126				

4" Single Flanged Internal Valve

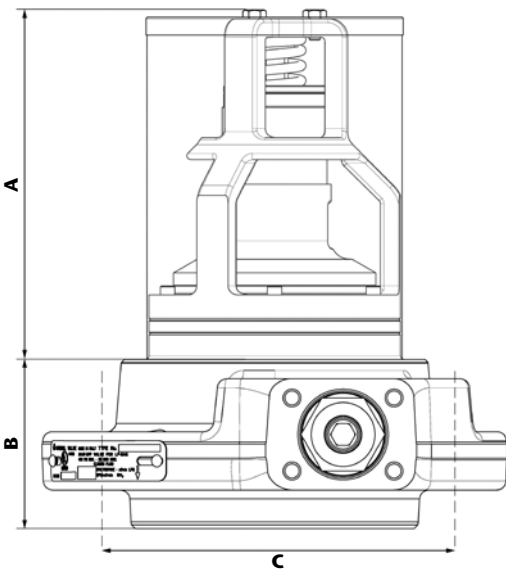

Flanged Valves specification:
 Pressure Rating: 400 PSI (27.58 bar) WOG
 Temperature: Up to 150°F (66°C)
 Body: hot forged steel
 Packing: PTFE
 Seat disk: Synthetic rubber
 Stub, Shaft & Stem: stainless steel
 Gaskets: Non asbestos spiral wound graphite

DIMENSIONS		
A	B	C
Single	Single	Single
7,55" (192 mm)	3,66" (93 mm)	7,88" (200 mm)

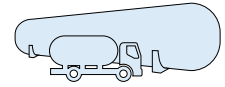

Threaded and Flanged Internal Valve Accessories

3" Single Flanged Valve

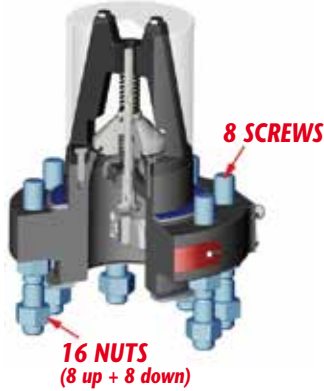

Product Code	Description
680390020	3/4"-10 UNC studs kit (8 pcs)
680390019	3/4"-10 UNC nuts kit (16 pcs)
0401105575	Upper spiral gasket (1 pcs)
0401105576	Lower spiral gasket (1 pcs)
680390021	M20x2,5 studs kit (8 pcs)
680390022	M20x2,5 nuts kit (16 pcs)

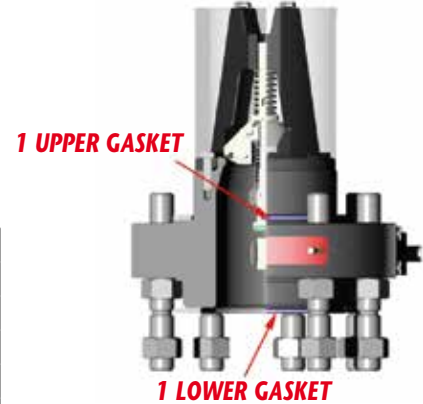

3" Double Flanged Valve

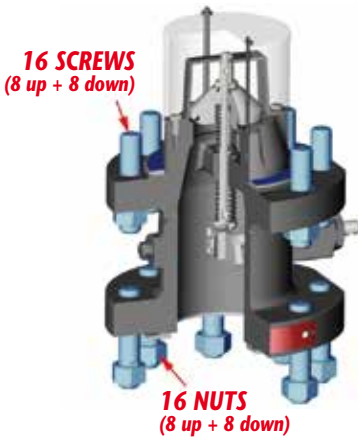

Product Code	Description
680390018	3/4"-10 UNC studs kit (16 pcs)
680390019	3/4"-10 UNC nuts kit (16 pcs)
0401105575	Upper spiral gasket (1 pcs)
0401105576	Lower spiral gasket (1 pcs)

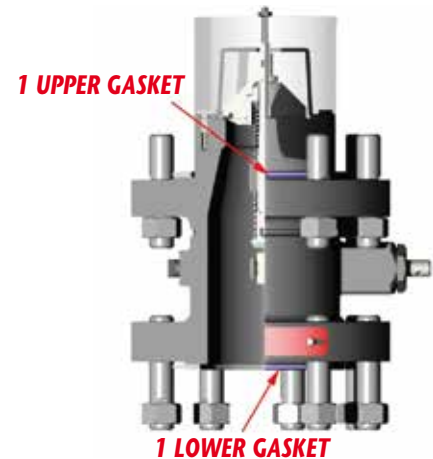

4" Single Flanged Valve

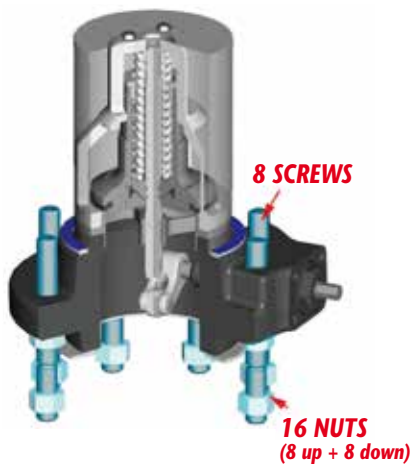

Product Code	Description
680390023	3/4"-10 UNC studs kit (8 pcs)
680390019	3/4"-10 UNC nuts kit (16 pcs)
0401105595	Upper spiral gasket (1 pcs)
0401105596	Lower spiral gasket (1 pcs)

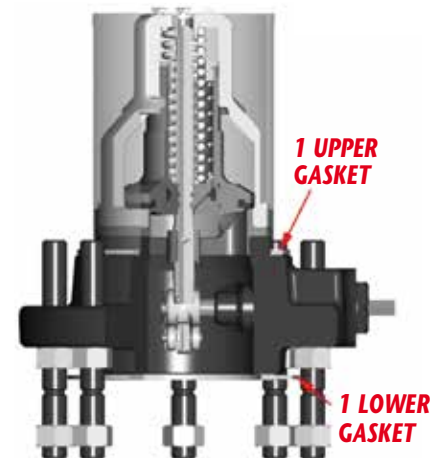

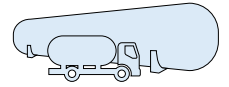

Threaded and Flanged Internal Valve Accessories

Spiral Gaskets

Product Code	Description
0401105575	Upper Spiral Gasket 3" Flanged Valve (Single and Double)
0401105576	Lower Spiral Gasket 3" Flanged Valve (Single and Double)
0401105595	Upper Spiral Gasket 4" Single Flanged Valve
0401105596	Lower Spiral Gasket 4" Single Flanged Valve

Main Spindle Assembled Kit

Product Code	Description
6803900024	Dedicated for Internal Valve 1-1/4" and 1-1/2" - 1 pcs
6803900025	Dedicated for Internal Valve 2" (1 way and 2 ways) - 1 pcs
6803900026	Dedicated for Internal Valve 3" (1 way and 2 ways) - 1 pcs
6803900027	Dedicated for 3" Single Flanged Valve - 1 pcs
6803900028	Dedicated for 3" Double Flanged Valve - 1 pcs

Assembled Opening System Kit

Product Code	Description
6803900032	Dedicated for Internal Valve 1-1/4" and 1-1/2" - 1 pcs
6803900033	Dedicated for Internal Valve 2" (1 way and 2 ways) - 1 pcs
6803900034	Dedicated for Internal Valve 3" (1 way and 2 ways) - 1 pcs
6803900035	Dedicated for 4" Single Flanged Valve - 1 pcs

Complete soft sealings kit (all the or and gaskets)

Product Code	Description
6803900040	Dedicated for Internal Valve 1-1/4" and 1-1/2" - 1 pcs
6803900041	Dedicated for Internal Valve 2" (1 way and 2 ways) - 1 pcs
6803900042	Dedicated for Internal Valve 3" (1 way and 2 ways) - 1 pcs
6803900043	Dedicated for 3" Single Flanged Valve - 1 pcs
6803900044	Dedicated for 3" Double Flanged Valve - 1 pcs
6803900045	Dedicated for 4" Single Flanged Valve - 1 pcs

Studs and Nuts

Product Code	Description
6803900018	3/4"-10 UNC studs kit (16 pcs)
6803900019	3/4"-10 UNC nuts kit (16 pcs)
6803900020	3/4"-10 UNC studs kit (8 pcs)
6803900021	M20x2,5 studs kit (8 pcs)
6803900022	M20x2,5 nuts kit (16 pcs)
6803900023	3/4"-10 UNC studs kit (8 pcs)

Assembled Cone Kit

Product Code	Description
6803900029	Dedicated for Internal Valve 1-1/4" and 1-1/2" - 1 pcs
6803900030	Dedicated for Internal Valve 2" (1 way and 2 ways) - 1 pcs
6803900031	Dedicated for Internal Valve 3" (1 way and 2 ways) and 3" Flanged Valve (Single and Double) - 1 pcs

Soft sealings kit only for assembled opening system

Product Code	Description
6803900036	Dedicated for Internal Valve 1-1/4" and 1-1/2" - 1 pcs
6803900037	Dedicated for Internal Valve 2" and 3" (1 way and 2 ways) - 1 pcs
6803900038	Dedicated for 3" Single and Double Flanged Valve - 1 pcs
6803900039	Dedicated for 4" Single Flanged Valve - 1 pcs

Excess Flow Spring

Product Code	Description
6803900046	Dedicated for 30 GPM - Internal Valve 1-1/4" and 1-1/2"
6803900047	Dedicated for 50 GPM - Internal Valve 1-1/4" and 1-1/3"
6803900048	Dedicated for 80 GPM - Internal Valve 1-1/4" and 1-1/4"
6803900049	Dedicated for 100 GPM - Internal Valve 2"
6803900050	Dedicated for 150 GPM - Internal Valve 2"
6803900051	Dedicated for 250 GPM - Internal Valve 2"
6803900052	Dedicated for 150 GPM - Internal Valve 3" and 3" Flanged (Single and Double)
6803900053	Dedicated for 200 GPM - Internal Valve 3" and 3" Flanged (Single and Double)
6803900054	Dedicated for 250 GPM - Internal Valve 3" and 3" Flanged (Single and Double)
6803900055	Dedicated for 400 GPM - Internal Valve 3" and 3" Flanged (Single and Double)
6803900056	Dedicated for 500 GPM - Internal Valve 3" and 3" Flanged (Single and Double)
6803900057	Dedicated for 340 GPM - 4" Single Flanged Valve
6803900058	Dedicated for 440 GPM - 4" Single Flanged Valve
6803900059	Dedicated for 600 GPM - 4" Single Flanged Valve
6803900060	Dedicated for 800 GPM - 4" Single Flanged Valve
6803900061	Dedicated for 1000 GPM - 4" Single Flanged Valve

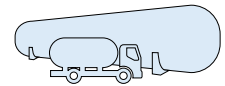

Rotary Cams Actuators



Features:

- The actuator is preassembled and ready to install.
- Compared to current devices which require adjustments the installment is quick and easy (3 screws and 1 split pin).
- The actuator can be fitted to the valve in four separate positions allowing optimization of space on the vehicle.
- Direct drive design does not apply side load to internal valve stem packing for maximum valve life.
- The actuator uses an internal cam mechanism, which guarantees higher performance optimizing the opening torque.
- Torque moment: The return torque moment relies only on the spring and is independent from the supply pressure.
- Immediate and automatic closing in absence of air (no need for additional rapid discharge accessories).
- OPEN/CLOSE indicator.
- Compact design and lightweight.
- Aluminum body, components in stainless steel and aluminum.
- Valve anchoring bracket made in stainless steel.
- The actuator is self-lubricating with PTFE carbon-graphite seals.
- The actuator guarantees complete opening of the valve and is equipped with limit switch.
- Operating media: compressed filtered air, not necessarily lubricated.
- 500.000 opening cycles guaranteed.

Actuator 1-1/4" and 1-1/2"

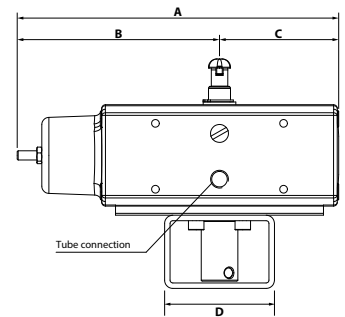
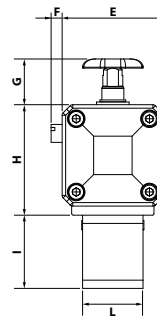
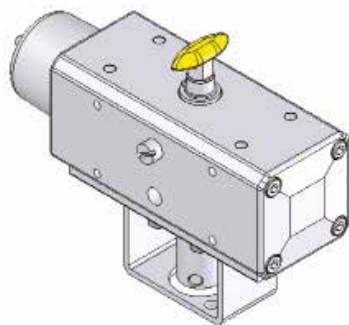

Actuator 2" and 3"

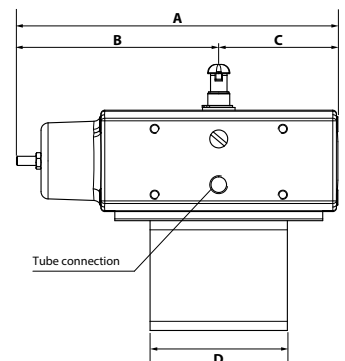
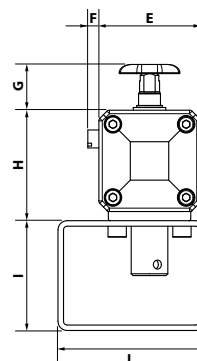
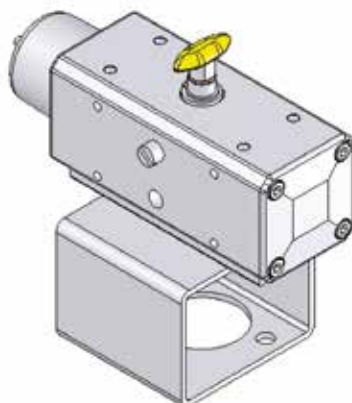

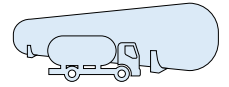

Rotary Cams Actuators

Actuator 3" SINGLE FLANGED

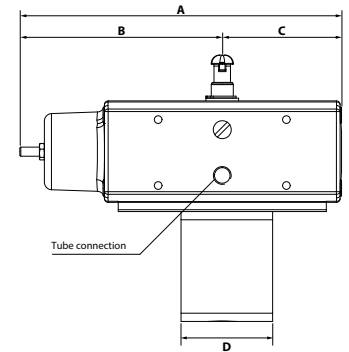
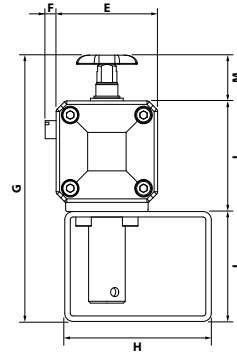
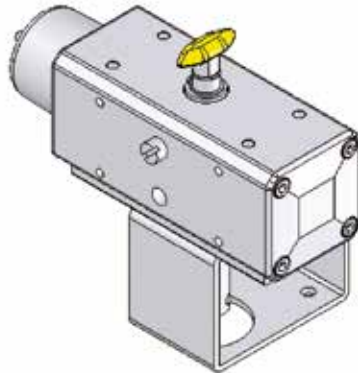

Actuator 3" DOUBLE FLANGED

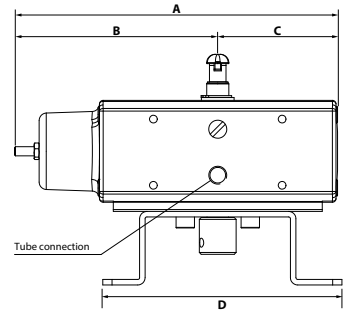
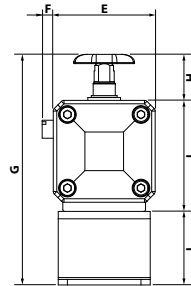
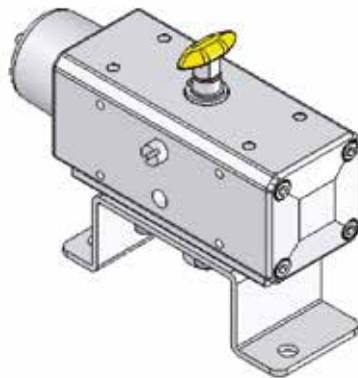

Actuator 4" SINGLE FLANGED

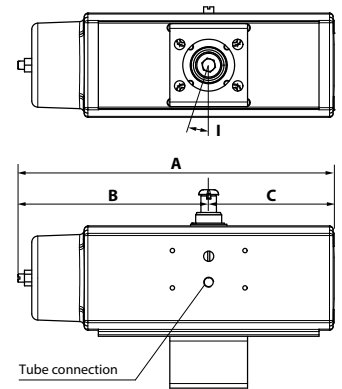
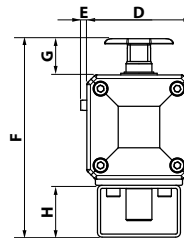
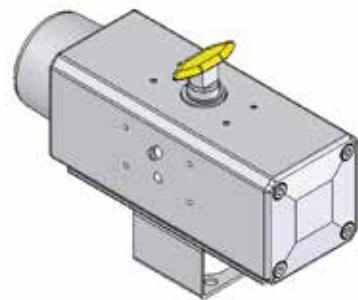

Rotary Cams Actuators Dimensions (mm)													
		A	B	C	D	E	F	G	H	I	L	M	Ø tube connection
3000900000	O-205 Actuator 1-1/4" and 1-1/2"	175,6	110,5	65,1	60	55,4	6	25	60,4	40	33	-	1/4"
3000900001	O-206 Actuator 2" and 3"	175,6	110,5	65,1	75	55,4	6	25	60,4	60	80	-	1/4"
3000900002	O-207 SF Actuator 3" Single Flanged	175,6	110,5	65,1	50	55,4	6	145,4	80	60	60,4	25	1/4"
3000900003	O-207 Actuator 3" Double Flanged	175,6	110,5	65,1	130	55,4	6	125,4	25	60,4	40	-	1/4"
3000900004	O-208 SF Actuator 4" Single Flanged	305	184,1	120,9	100,4	6	191,4	35	50	17,5°	-	-	1/4"
3000900014	O-205 Actuator 1-1/4" and 1-1/2" tube Ø6 mm	175,6	110,5	65,1	60	55,4	6	25	60,4	40	33	-	6 mm
3000900015	O-206 Actuator 2" and 3" tube Ø6 mm	175,6	110,5	65,1	75	55,4	6	25	60,4	60	80	-	6 mm
3000900016	O-207 SF Actuator 3" Single Flanged tube Ø6 mm	175,6	110,5	65,1	50	55,4	6	145,4	80	60	60,4	25	6 mm
3000900017	O-207 Actuator 3" Double Flanged tube Ø6 mm	175,6	110,5	65,1	130	55,4	6	125,4	25	60,4	40	-	6 mm
3000900018	O-208 SF Actuator 4" Single Flanged tube Ø6 mm	305	184,1	120,9	100,4	6	191,4	35	50	17,5°	-	-	6 mm
3000900019	O-205 Actuator 1-1/4" and 1-1/2" tube Ø8 mm	175,6	110,5	65,1	60	55,4	6	60,4	60,4	40	33	-	8 mm
3000900020	O-206 Actuator 2" and 3" tube Ø8 mm	175,6	110,5	65,1	75	55,4	6	60,4	60,4	60	80	-	8 mm
3000900021	O-207 SF Actuator 3" Single Flanged tube Ø8 mm	175,6	110,5	65,1	50	55,4	6	80	80	60	60,4	25	8 mm
3000900022	O-207 Actuator 3" Double Flanged tube Ø8 mm	175,6	110,5	65,1	130	55,4	6	25	25	60,4	40	-	8 mm
3000900023	O-208 SF Actuator 4" Single Flanged tube Ø8 mm	305	184,1	120,9	100,4	6	191,4	50	50	17,5°	-	-	8 mm

High Performace actuator available upon request

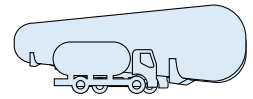

Latch/Remote Release Mechanisms

All Cavagna brand Internal Valves can be fitted with a manual Latch/remote release mechanism. When the Internal valve's operating lever is manually moved to the open position, the lever can be latched in the open position. The lever can be release from a remote location by pulling on the cable attached to a pull ring, thus closing the internal valve. A built-in fusible element in the latch release melt if exposed to fire allowing the operating lever to return to the closed position. (for the temperature 212°F/100°C)



Cod. **1309500142**



Cod. **1309500143**



Cod. **1309500144**



Cod. **1309500147**

Cod.	Description
1309500142	Fuse latch threaded Internal valve 2" and 3"
1309500143	Fuse latch threaded Internal valve 1-1/4" and 1-1/2"
1309500144	Dual Latch/ remote release for Internal valve 1-1/4" and 1-1/2"
1309500147	Manual lever and release on for 4"

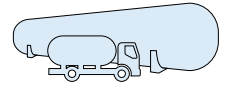

Accu-Max Float Gauges



Application:

Measure liquid levels within horizontal DOT and Stationary ASME Tanks with fluid capacities above 2,300 gallons. Suitable for use in bobtail, transport, railcar and bulk storage applications.

Features:

- All stainless steel construction for use with LPG & NH₃ applications
- Welded tube to coupling design for maximum strength and durability
- Integral spring loaded shock absorber for arduous over-the-road application
- Exclusive easy to read "glow in the dark" dial face perfect for low light situations Dial face 100% sealed and argon filled to prevent moisture build-up & fogging Factory set and precision tuned for superb accuracy Dial face and mounting hardware universal with other industry standard gauges Mounts to all standard 8 bolt tank flange adapters

DOT Float Gauges			
Part No.	Description	Dial Face	Tank Diameter
ME930-72	Accu-Max DOT Float Gauge Assembly	Glow / Black	Available in different sizes
ME930-79	Accu-Max DOT Float Gauge Assembly	Glow / Black	
ME930-84	Accu-Max DOT Float Gauge Assembly	Glow / Black	
ME930C-72	Accu-Max DOT Float Gauge Assembly (Classic)	Silver / Black	72"
ME930C-79	Accu-Max DOT Float Gauge Assembly (Classic)	Silver / Black	79"
ME930C-84	Accu-Max DOT Float Gauge Assembly (Classic)	Silver / Black	84"

ASME Stationary Float Gauges			
Part No.	Description	Dial Face	Tank Diameter
ME940-108	Accu-Max Stationary Float Gauge Assembly	Glow / Black	108"
ME940-130	Accu-Max Stationary Float Gauge Assembly	Glow / Black	130"
ME940C-108	Accu-Max Stationary Float Gauge Assembly (Classic)	Silver / Black	108"
ME940C-130	Accu-Max Stationary Float Gauge Assembly (Classic)	Silver / Black	130"

Accessories and Replacement Parts	
Part No.	Description
ME930-805	Replacement Accu-Max DOT Float Gauge Dial - Glow / Black
ME930C-905	Replacement Accu-Max DOT Float Gauge Dial - Silver / Black (Classic)
ME940-905	Replacement Accu-Max Stationary Float Gauge Dial - Glow / Black
ME940C-905	Replacement Accu-Max Stationary Float Gauge Dial - Silver / Black (Classic)
ME931	8 Bolt Mounting Flange Adapter 2-1/2" MNPT - Steel
ME932	8 Bolt Mounting Flange Adapter - Weld Type - Steel

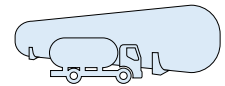

Rotary Gauge System



Cavagna Group rotary gauges can be used on stationary or mobile tanks to visually indicate the amount of LP-Gas in the container. They are also used in filling the tank to the proper liquid level. On mobile applications and some large stationary storage tanks, hangers are recommended to support the horizontal length of the dip tube.

The gauge is operated by opening the small bleed orifice when the tube is in the vapor space of the tank. Moving the pointer on the dial causes the end of the tube to move until it contacts liquid in the container. At that point, discharge from the bleed orifice turns from vapor to liquid and the rotary gauges dial gives the volume percentage of liquid in the tank.

Gauges fit 1" coupling container connections. All gauges have stem and dip tubes with an extra large inside diameter. This assures that the correct liquid level can be obtained quickly.

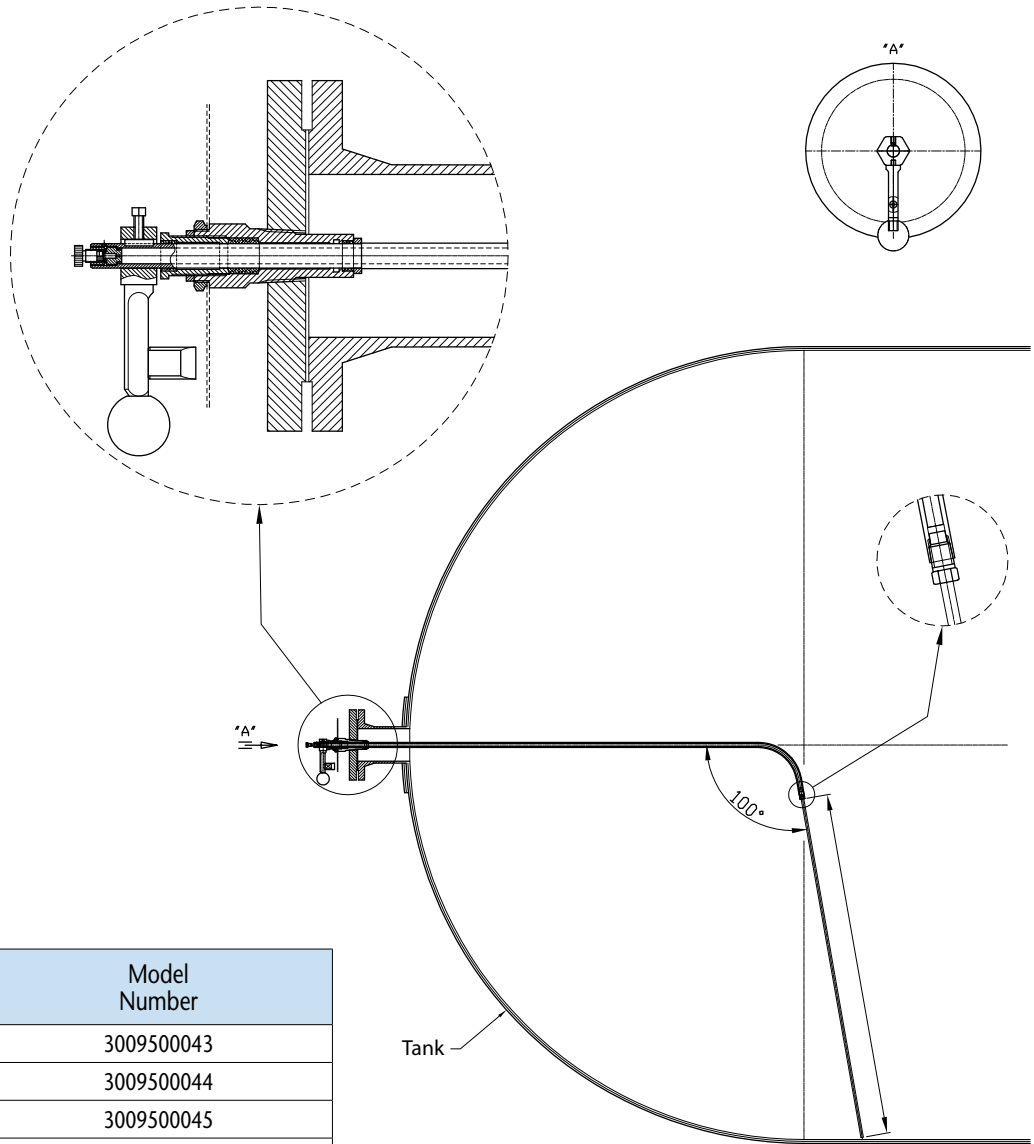

Length in Inches (Diameter of Tank)	Model Number
68	3009500043
69-92	3009500044
93-108	3009500045
109-140	3009500046
Dial only LP	3001102709

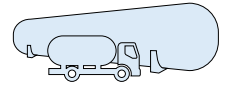

Excess Flow Valves for Liquid or Vapor

Valves are designed for Liquid or Vapor fill / withdrawal and for vapor equalization in containers or line applications. They are intended to close when the liquid or vapor passing through the hose or the piping system exceeds the prescribed flow rate. Valves are available in different sizes and body configurations.

VALVE'S FUNCTIONING.

Once the flow exceeds the valve's setting, the valve closes and will remain closed until the system equalizes. Once the pressure on both sides of the poppet is equal, a built in equalizing passage automatically opens the valve.



Part Number	Material	Inlet Connection	Outlet Connection	Wrench Hex Flats	Length	Approximate Closing Flows		
						Liquid (GPM Propane)	25 PSIG Inlet	100 PSIG Inlet
6902900127	Steel	1-1/4"	1-1/4"	2"	1 5/16"	30	5750	9800
6902900128	Steel	1-1/4"	1-1/4"	2"	1 5/16"	40	7500	13330
6902900129	Steel	1-1/4"	1-1/4"	2"	1 5/16"	50	8800	15970

Excess Flow Valves for Liquid or Vapor withdrawal

Valves are designed to be mounted on the bottom of customer storage tanks for liquid service. They may also be mounted on the top for vapour service.



Part Number	Material	Inlet Connection	Outlet Connection	Wrench Hex Flats	Approximate Closing Flows
					Liquid (GPM Propane)
6901900036	Steel	1-1/4"	1-1/4"	1 7/8"	55
6901900037	Steel	1-1/4"	1-1/4"	1 7/8"	70



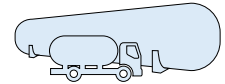

Flanged Excess Flow Valves



Features:

- Galvanized Steel Body
- PN 40 Flanges
- Stainless steel Spring
- Stainless steel Stem

Other flanges rating on request.

Part Number	DN Ø
VEF 2	DN 20
VEF 4	DN 25
VEF 32	DN 32
VEF 34/1.0	DN 40
VEF 38/1.0	DN 50
VEF 42	DN 65
VEF 46	DN 80

Flanged Back Check valves



Features:

- Galvanized Steel Body
- PN 40 Flanges
- Stainless steel Spring
- Stainless steel Stem

Part Number	DN Ø
VNR 2	DN 20
VNR 3	DN 25
VNR 15	DN 32
VNR 17	DN 40
VNR 18/1.0	DN 50
VNR 19	DN 65
VNR 20	DN 80

Wafer Excess Flow Valves

The VEF-W25 is a new excess flow valve useful to reduce costs and space of the installation.

Features:

- Design temperature: -40/+60 °C
- Connection: UNI PN40
- Max pressure: 25 bar
- Body material: A350 LF2
- Surface treatment: galvanized
- Stainless steel spring
- Stainless steel stem
- Closure of gas phase at: 180kg/h if 1,72 bar; 300 kg/h if 6,9 bar

Part Number	Description	DN
VEF-W25	Excess flow valve DN25 PN 40	25



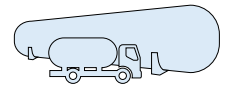

Back Pressure Valves for Container or Line Applications



Valves are intended to prevent liquid discharge when the desired flow is directed into the vessel thereby allowing the flow in only one direction.

When coupled with the appropriate single check filler valve, the combination forms a double check filler valve suitable for use in filling of bulk storage tanks.

Part Number	Material	Inlet Connection	Outlet Connection	Wrench Hex Flats	Length	Propane Liquid Capacity at different Δ Pressure		
						5 PSIG	10 PSIG	25 PSIG
7100900051	Steel	3/4" F NPT	3/4" M NPT	1 3/8"	1 15/16" (49,2 mm)	10,75	15,7	24,5
7100900050	Steel	1-1/4" F NPT	1-1/4" M NPT	2"	2-1/2" (63,5 mm)	27,5	39,2	61,75
7100900049	Steel	2" F NPT	2" M NPT	3"	3 3/8" (83,5 mm)	121,5	171,5	270,5
7100900109	Brass	1-1/4" F NPT	1-1/4" M NPT	2"	2-1/2" (63,5 mm)	27,5	39,2	61,75

LPG Filling Head for Manually Operated Tank Filler Valves

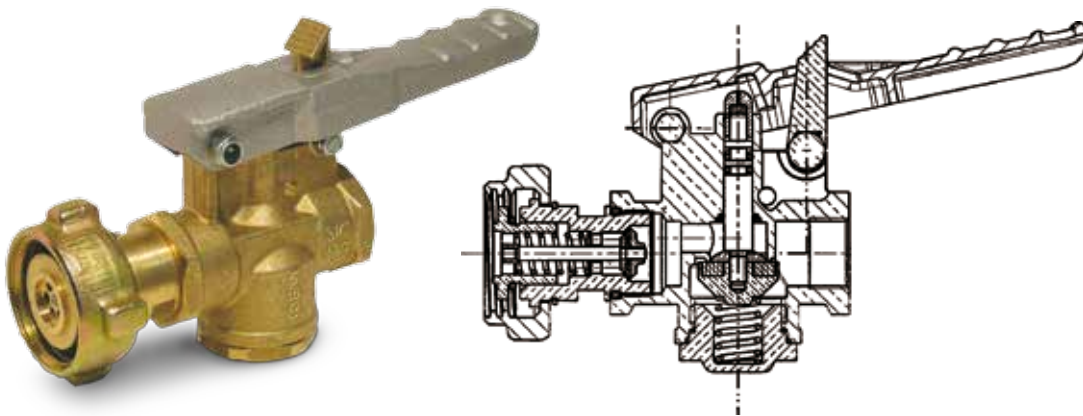

Materials and standards

The Filling Head is made of corrosion-resistant materials such as stainless steel, brass, aluminium and special polymers. The rubber materials used are developed and manufactured according to the requirements of EN 549.

Features

1. Easy and safe to connect and disconnect. Filling is initiated by operating the manual handle.
2. Slim design makes it easy to handle and it fits easily inside any shroud.
3. Safety lock for disconnection.
4. The safe valve connection assures that the LPG can only flow when the filling head is leak tight connected to a filler valve.
5. **Automatic vent valve incorporated.**

Part No.	Inlet connection	Outlet connection	Supply pressures
6882900057	3/4" NPT	1-3/4" x 6 ACME - 2g connects to Cavagna filler valves like 66.0.290.1043, 6602901122	The Filling Head is designed to operate within the normal LPG supply pressures. Liquid filling product: 1-15 bar.

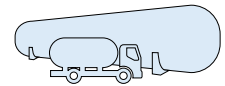

Hose end Swivel Connectors

The hose end swivel connector allows the hose end valve to rotate 360° creating an easier connection to the tank filler valve while under pressure. It also promotes hose life by preventing twisting and kinking during reeling and unreeling from hose reel.



Hose End Swivel Connector Features

- All stainless steel construction for maximum durability and corrosion resistance
- Large bearing surface for increased strength and durability
- 360° rotation under maximum working pressure of 400 psig
- Our UL listed seal pack design allows for extremely long life with no maintenance required
- Straight through bore for unobstructed flow characteristics
- See low emission hose end valves for factory installed E-ZTurn

Part No.	Inlet (FNPT)	Outlet (MNPT)
ME850SS-6	3/4"	3/4"
ME8850SS-6/8	3/4"	1"
ME850SS-8	1"	1"
ME850SS-8/6	1"	3/4"



I - Empty EZ Unloading adapter for Container Evacuation

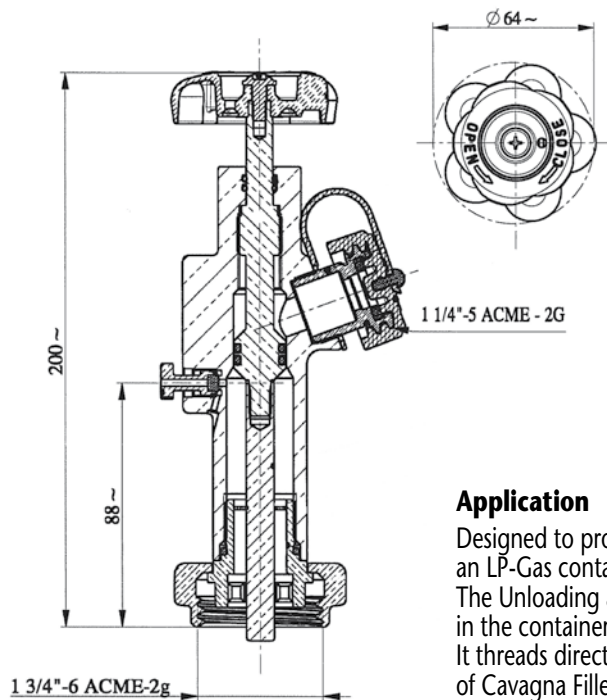

Application

Designed to provide an efficient means of evacuating an LP-Gas container for relocation or repair. The Unloading adapter can be used to withdraw liquid provided in the container and withdraw the remaining Vapor phase. It threads directly onto 1-3/4" ACME male hose connection of Cavagna Filler Valve series VRN.

Caratteristiche Material

- Brass:** UNI EN 12164
- Handwheel:** Aluminium UNI EN 1706
- Rubber seals:** UNI EN 549
- Working Temperature:** -20C° : +60C° (-4°F : 140°F)

Part Number	Style	Filler Valve Connection	Hose Connection
68 0 290 0211	In-Line	1-3/4" ACME	1-3/4" ACME

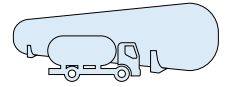

Quick Acting Dispensing Valves

Dispensing valves are designed to be used at the end of a filling hose on a bobtail, dispensing system or nurse tank filling operations. These valves have instant full-on flow with the added protection of a quick closing, self-locking handle to prevent accidental opening of the valve during transport.

Quick Acting Dispensing Valve Features

- All stainless steel internal components
- Self-locking toggle handle prevents accidental operation
- Durable ductile iron valve body with automotive grade powder coat finish
- Toggle handle and stem assembly rotates 360°
- Stainless steel factory installed vent valve



ME820



Hose End Fill Check Adapters

These adapters are intended to be attached to the LP-Gas delivery truck hose outlets. They feature minimal flow restriction which allows for fast delivery while providing an integral check valve to prevent further product loss if the tank fill valve fails to close. In the event the tank fill valve should fail, leave the fill adapter connected to the fill valve and disconnect the filler hose end valve. Then place the filler valve cap onto the fill adapter. The tank fill valve should be repaired immediately.

Hose End Fill Adapter Features

- Integral breakaway feature in the event of truck roll away leaving check intact on tank
- 1009500280 shortest overall height in the industry allowing adapters to fit inside tank hood
- 1009500281 has a floating internal seat design which allows check to swivel freely when installed on hose end valve



1009500280



1009500281

Part No.	Filler Valve F. Acme Connection	Hose End M. Acme Connection	Handle Style	Handle Material	Swivels	Factory Installed Vent Valve	Extended Version	Additional Keys
1009500280	1-3/4"	1-3/4"	Standard	Brass	No	No	No	-
1009500281	1-3/4"	1-3/4"	Standard	Brass	Yes*	No	No	-

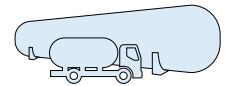

High Flow Globe & Angle Valves

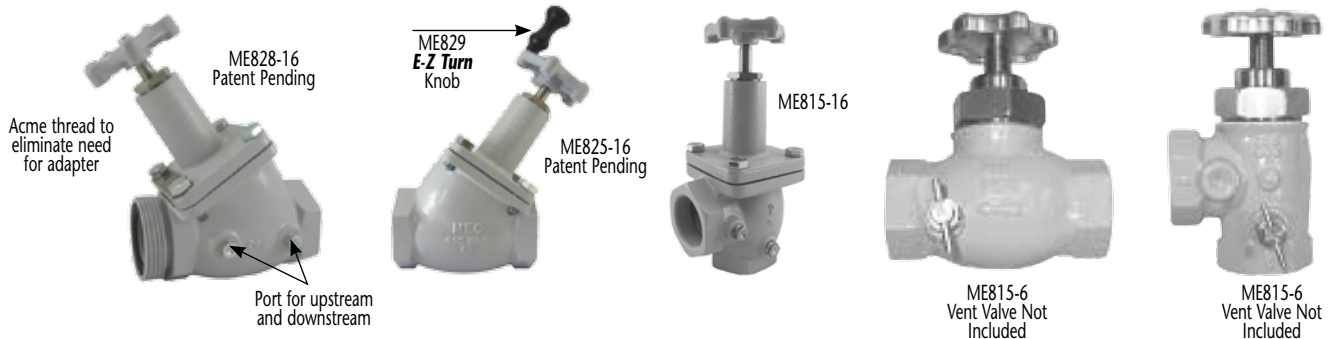

High Flow Globe and Angle Valve Features

- All stainless steel internal components with rotating seat disc design & V-cup Teflon® packing stem seals
- Double stem seal design ensures leak free operation
- Double lead stem thread ensures quick and efficient operation
- Durable ductile iron valve body with automotive grade powder coat finish
- 1-1/4" & larger globe valves have 35° seat angle for maximum product flow
- 1-1/4" & larger globe valve designed ergonomically correct for bobtail transport and bulk plant applications
- 1-3/4", 2-1/4" & 3-1/4" Acme threads available on globe valves
- Rated for 400 WOG
- Operating temperature -40° to +212° Fahrenheit

Part No.		Inlet (FNPT)	Outlet	Side Port (FNPT)	No. of Side Ports	Flange Style Bonnet	Accessories			
Angle	Globe						E-Z Turn Knob	Hydrostatic Relief Valves	Vent Valves	
ME815-4	ME825-4	1/2"	1/2" FNPT	1/4"	1	No	-	MEH225 MEH225SS MEH25/450	MEJ400 MEJ402S	
ME815-6	ME825-6	3/4"	3/4" FNPT	1/4"	1	No	-			
ME815-8	ME825-8	1"	1" FNPT	1/4"	1	No	-			
ME815-10	ME825-10	1-1/4"	1-1/4" FNPT	1/4"	2	Yes	ME829			
-	ME826-10	1-1/4"	1-3/4" M. Acme	1/4"	2	Yes	ME829			
-	ME827-10	1-1/4"	2-1/4" M. Acme	1/4"	2	Yes	ME829			
ME815-12	ME825-12	1-1/2"	1-1/2" FNPT	1/4"	2	Yes	ME829			
ME815-16	ME825-16	2"	2" FNPT	1/4"	2	Yes	ME829			
-	ME824-16	2"	2" FNPT	1/2"	2	Yes	ME829			
-	ME828-16	2"	3-1/4" M. Acme	1/4"	2	Yes	ME829			
ME815-24	ME825-24	3"	3" FNPT	1/4"	2	Yes	included	MEH50/460	-	
									MEH225 MEH225SS MEH25/450	MEJ400 MEJ402S

To order Teflon® or Viton® Seal add "T" for Teflon® and "V" for Viton® after the prefix part number i.e. ME815T-10 or ME815V-10

Teflon® is a trademark of DuPont Company and Viton® is a trademark of DuPont Performance Elastomers.

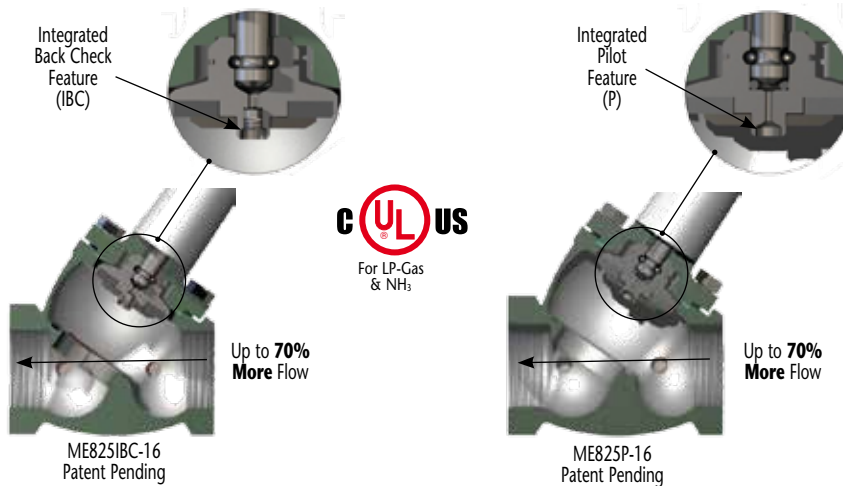

Part No.		Inlet (FNPT)	Outlet	Side Port (FNPT)	No. of Side Ports	Flange Style Bonnet	Accessories		
Angle	Globe						E-Z Turn Knob	Hydrostatic Relief Valves	Vent Valves
ME815IBC-16	ME815P-16	2"	2" FNPT	1/4"	2	Yes	ME829	MEH225 MEH225SS MEH25/450	MEJ400 MEJ402S
-	-	2"	3-1/4" M. Acme	1/4"	2	Yes	ME829		
-	-	2"	2" FNPT	1/2"	2	Yes	ME829		



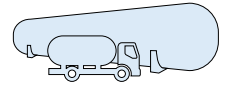

Full Internal Relief Valves



Application:

Designed for use in mobile LPG & NH₃ containers as a primary pressure relief valve for bobtail and transport trailer installations. All working components are internal to the container connection preventing damage to the valve should a roll-over incident occur.

Features:

- Durable stainless steel body construction.
- All stainless steel internal components for maximum corrosion resistance.
- Available with Nitrile valve seals.
- Large seating surface for superior seal performance & reliability.
- Available with 250 & 265 PSI set pressures.

Part Number	STD / PSIG	Container Connection	Installation Hex	Service		Seat Material
				LPG	NH ₃	
6602901295	250	2" MNPT	1-1/2"	Yes	Yes	Nitrile
6602901300	265	2" MNPT	1-1/2"	Yes	Yes	Nitrile
6602901296	250	3" MNPT	2-1/2"	Yes	Yes	Nitrile
6602901301	265	3" MNPT	2-1/2"	Yes	Yes	Nitrile



Flanged Full Internal Relief Valves



Application:

Designed for use in mobile LPG & NH₃ containers as a primary pressure relief valve for bobtail and transport trailer installations. All working components are internal to the container connection preventing damage to the valve should a roll-over incident occur. Our unique design incorporates a standard 3" - 300LB. raised face flange connection to assure a 100% leak free connection for rugged over the road applications. This eliminates problems associated with NPT threaded connections and/or tank coupling wear providing maximum tank and relief valve service life.

Features:

- Durable single piece stainless steel body construction.
- All stainless steel internal components for maximum corrosion resistance.
- Available with Nitrile.
- Large seating surface for superior seal performance & reliability.
- Available with 250 & 265 PSI set pressures.

Part Number	STD / PSIG	Container Connection	Installation Hex	Service		Seat Material
				LPG	NH ₃	
6602901325	250	3" 300 LB Flange	2-1/2"	Yes	Yes	Nitrile
6602901326	265	3" 300 LB Flange	2-1/2"	Yes	Yes	Nitrile

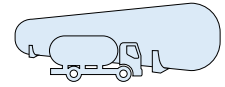

Combination Valves



MEJ415G

Developed to mount a pressure gauge and fixed tube liquid level gauge all in one valve. The shutoff portion of the valve increases the pressure gauge's life and accuracy by eliminating constant gauge pressure and allows for easy gauge replacement. To replace a gauge simply close the valve and open the vent valve to relieve pressure before disassembling pressure gauge.

The valve can be installed at the maximum fill level or an 1/8" MNPT dip tube can be installed on the container connection side to set any liquid level desired. For use in ASME bulk storage containers and DOT transport tank installations.

Combination Valve Features

- All steel and stainless steel component construction
- Integral #54 orifice provides gauge dampening protection
- Durable ductile iron body with automotive grade powder coat finish or plated steel body



MEJ415

Part No.	Material	Container Connection MNPT	Two Service Connections FNPT	Dip Tube Connection FNPT	Accessories	
					Stainless Steel Vent Valve	Stainless Steel 0-400 PSIG Pressure Gauge
MEJ415	Steel	3/4" MNPT	1/4" FNPT	1/8"	MEJ402S	MEJ542
MEJ415G	Steel	3/4" MNPT	1/4" FNPT	1/8"	Included	Included

Container Thermometers



Designed for use in LP-Gas or NH₃ storage tanks, nurse tanks, bobtails and transports. These stainless steel, dust and water proof thermometers have 1/2" MNPT connection with a temperature range from -40° to +120° Fahrenheit.

Part No.	Dial Diameter	Probe Length
MEJ700	2"	4"
MEJ701	2"	6"
MEJ702	3"	4"
MEJ703	3"	6"

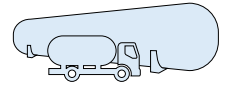

Liquid Transfer Valves & Adapters

Designed to provide a safe means by which to transfer liquid from a tank during an emergency or container relocation. These valves can be equipped with an integral excess flow device for direct product transfer or without when used in conjunction with liquid withdrawal adapter (ME458 Series) and tank valve (ME460 & ME462 Series).

Warning: An excess flow valve will not activate if there is a break or leak downstream of the valve that does not equal or exceed the closing flow of the valve or if the excess flow valve installed exceeds the flow capacity of the system. See the Excess Flow Warning page for more information regarding the use of excess flow.

Liquid Transfer Valve Features

- Double O-ring stem seal design ensures leak free operation
- Double lead stem thread ensures quick and efficient operation
- 3/4" MNPT inlet x 3/4" FNPT outlet
- Additional features for steel transfer valves
- All stainless steel internal components
- Durable ductile iron valve body with automotive grade powder coat finish
- Equipped with convenient upstream and downstream 1/4" FNPT plugged ports for optional accessories



Tank Valve Features

- Provides excess flow protection in the event of a downstream connection or line failure
- Safety breakaway feature leaves valve seals intact in the event of truck roll-away
- 6-14 psig closing flow pressure differential for maximum product transfer
- Fully interchangeable with all existing valve models and adapters
- Additional features for steel and stainless steel tank valves
 - Meets requirements for installation into DOT storage containers like bobtails and transports
 - Steel model features a rust inhibitor compound between the cap and threads to prevent corrosion



Part No.	Material	Excess Flow	Closing Flow/GPM	Accessories							Hydrostatic Relief Valve	Vent Valve
				Liquid Withdrawal Adapter 3/4" FNPT x 1-5/8" UNF		Liquid Withdrawal Tank Valve 1-5/8" UNF Male						
				Brass	Steel*	3/4" MNPT	1-1/4" MNPT					
				Brass	Steel*	Stainless Steel*						
ME449	Brass	No	-	ME458	ME458S	ME460	ME462	-	-	MEH225 MEH25/450	MEJ400 MEJ400SC MEJ400/72 MEJ402S	
ME449H	Brass	No	-	ME458	ME458S	-	-	-	-	Factory Installed MEH225		
ME449S	Ductile Iron*	No	-	-	ME458S	-	-	ME462S	ME462SS	MEH225SS/300 MEH225SS/400 MEH225SS/440		
ME449EXS/22	Ductile Iron*	Yes	22	-	-	-	-	-	-			
ME449EXS/28	Ductile Iron*	Yes	28	-	-	-	-	-	-			

* Rated for LP-Gas & NH3

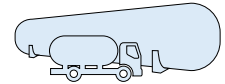

ACME Adapters



1009500248



1009500247

Part No.	INLET	OUTLET (M.NPT)
1009500246	1-3/4" M. Acme	1-1/4"
1009500248	1-3/4" M. Acme	3/4"
1009500249	1-3/4" M. Acme	1"
1009500263	3-1/4" M. Acme	3"
1009500264	3-1/4" M. Acme	2"
1009500247	1-3/4" M. Acme	1-3/4" M. Acme

Filler and Vapor



1009500257



1009500253

Part No.	INLET	OUTLET (M.NPT)
1009500251	1-3/4" F. Acme	3/4" M.NPT
1009500252	1-3/4" F. Acme	1" M.NPT
1009500253	1-3/4" F. Acme	1/2" M.NPT
1009500257	2-1/4" F. Acme	1-1/4"

ACME Cap



1009500254



1009500258



1009500262

Part No.	F. Acme (cap)
1009500254	1-3/4" F. Acme Cap Plug with Knob
1009500258	2-1/4" F. Acme Cap Plug with Knob
1009500262	3-1/4" F. Acme Cap Plug with Knob

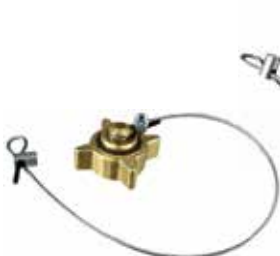

1009500277



1009500278



1009500279

Part No.	F. Acme (cap)
1009500277	1-3/4" F. Acme Cap Plug with Knob and metallic cable
1009500278	2-1/4" F. Acme Cap Plug with Knob and metallic cable
1009500279	3-1/4" F. Acme Cap Plug with Knob and metallic cable

ACME Adapters



1009500256



1009500259

Part No.	M. Acme	F.NPT	M.NPT
1009500255	1-1/4"	1/4"	1/2"
1009500256	1-1/4"	3/8"	3/4"
1009500259	2-1/4"	1"	1-1/2"
1009500260	2-1/4"	1-1/4"	2"
1009500261	2-1/4"	1-1/2"	2"

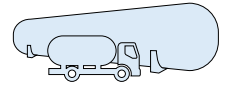

Manifold for Safety Relief Valves 2 Places For Lpg Tanks



For external spring safety relief valve

Each manifold can have 2 relief valves, both in service; it's possible to replace just one relief valve, while the remaining provides protection for the container.

Features:

- Execution body in steel A350 LF2 - WPL6
- Test pressure: 40 bar
- Leak test: 23 bar
- Design temperature: -40 + 50°C

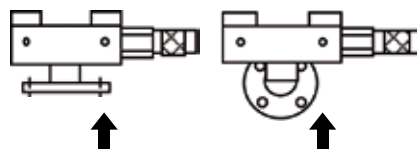
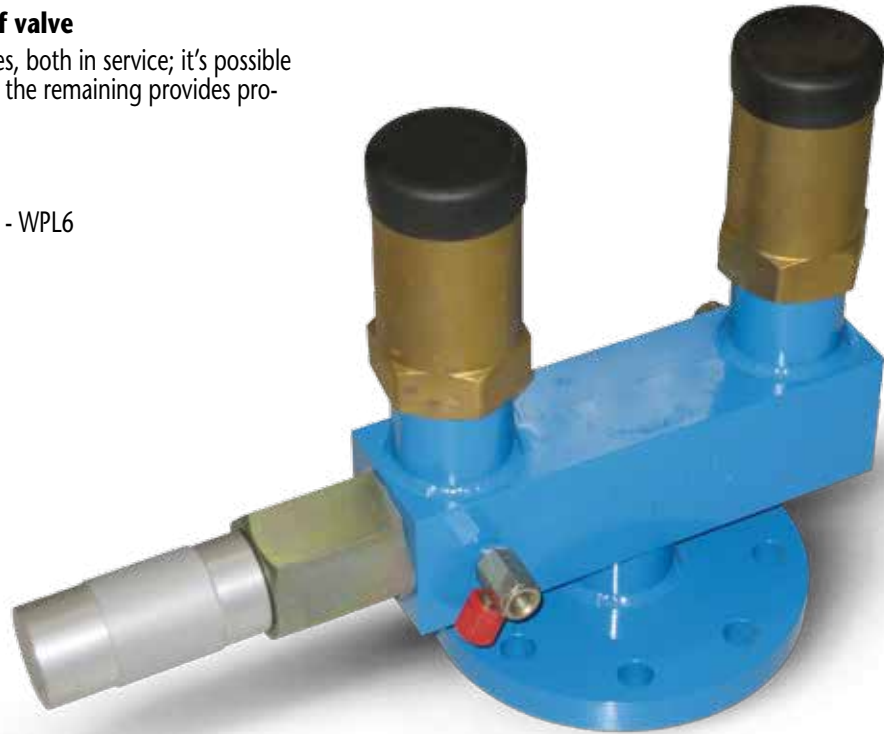

Connection for safety relief valve	Flanged connection to the tank	Vertical outlet code	Horizontal outlet code	Vent pipe code
F. Ø 1-1/4" NPSM	UNI PN40 DN50	CV-50-V-1	CV-50-O-1	TS-1-1/4"
	Ø 2" ANSI 300 RF	CV-2"-V-1	CV-2"-O-1	TS-1-1/4"
F. Ø 1-1/4" NPT	UNI PN40 DN50	CV-50-V-2	CV-50-O-2	TS-1-1/4"
	Ø 2" ANSI 300 RF	CV-2"-V-2	CV-2"-O-2	TS-1-1/4"
F. Ø 1-1/2" NPT	UNI PN40 DN50	CV-50-V-3	CV-50-O-3	TS-1-1/2"
	Ø 2" ANSI 300 RF	CV-2"-V-3	CV-2"-O-3	TS-1-1/2"
	UNI PN40 DN65	CV-65-V-3	CV-65-O-3	TS-1-1/2"
	Ø 2" 1/2 ANSI 300 RF	CV-2"1/2-V-3	CV-2"1/2-O-3	TS-1-1/2"
	UNI PN40 DN80	CV-80-V-3	CV-80-O-3	TS-1-1/2"
	Ø 3" ANSI 300 RF	CV-3"-V-3	CV-3"-O-3	TS-1-1/2"
F. Ø 2"1/2 NPT	UNI PN40 DN65	CV-65-V-4	CV-65-O-4	TS-2"1/2
	UNI PN40 DN100	CV-100-V-4	CV-100-O-4	TS-2"1/2
	Ø 3" ANSI 300 RF	CV-3"-V-4	CV-3"-O-4	TS-2"1/2

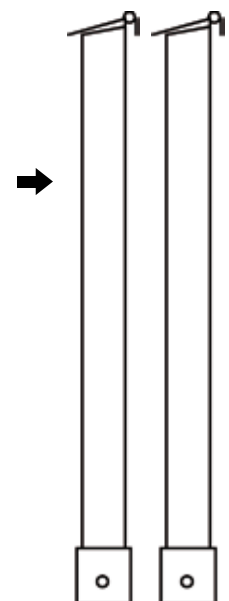

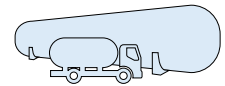

External Pressure Relief Valve

Designed for installation in stationary ASME applications such as bulk plant, skid tanks, underground and above ground containers, as the primary pressure relief valve.



VS 60
70.0.090.0080
Safety relief valve with big capacity. Designed for installation on ASME containers such as bulk plant, skid tanks, underground and above ground containers, as the primary pressure relief valve.



EU 30
70.0004
Pressure relief valve with cylindric thread to be used in connection with the lower check valve. Tightness assured by bonded seal.
Setting point: 17,65 bar.

PV 30
70.0.190.0208



EU 25
70.0205
Safety relief valve with cylindric thread to be used in connection with the lower check valve. Tightness assured by bonded seal.
Setting point: 17,65 bar.

PV 25
70.0.190.0205



Part Number*	Bottom Male Connection	Wrench grip hexagon (mm)	Thread type		Configuration suitable for this tank capacity:	PRV Start to Discharge Setting (bar)	PRV-OVERPRESSURE 10%	Approval	PRV Orifice (mm)
			taper	parallel			CAPACITY Nm ³ /min. (if not specified otherwise)		
70.0.090.0080 (VS 60) - PRV	2-1/2" NPT	110	x		10000 lt.	basic 17,65**	260,00	CE***	45,00
XX.X.XXX.XXXX (PV 60) - PRV									
70.0.190.0004 (EU 30) - PRV	1-1/4" NPSM	60		x	3000/5000 lt		107,00		29,50
70.0.190.0208 (PV 30) - PRV									
70.0.190.0207 (EU 25) - PRV									
70.0.190.0205 (PV 25) - PRV									



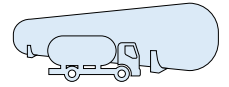

External Pressure Relief Valve



PRV 250
66.0.290.1139

Pressure relief valve for small containers and on-line pipe installations.
Setting point: 17,24 bar.



PRV 375
66.0.290.1140

Pressure relief valve for small containers and on-line pipe installations.
Setting point: 25,85 bar.

Designed for small containers and online pipe installation, to protect piping and shutoff valves from over pressure situations where LPG has the potential to be trapped. These relief valves provide pressure relief at or in excess of the stated pressure setting, protecting against line or plumbing system failures.

Part Number*	Bottom Male Connection	Wrench grip hexagon (mm)	Thread type	Configuration suitable for this tank capacity:	PRV - Start to Discharge Setting (bar)	PRV-OVERPRESSURE 10%	Approval	PRV Orifice (mm)
			Taper			CAPACITY Nm ³ /min. (If not specified otherwise)		
66.1139 - PRV	1/4-18 NPT	22	x	-	17,24	18,41 (at 120%O.P. SCFM-AIR)	UL/ASME	19,00
66.1140 - PRV	1/4-18 NPT	22	x	-	25,85	33,52 (at 120%O.P. AIR)	UL	19,00

Hydrostatic Pressure Relief Valves

Designed to protect piping and shutoff valves from over pressure situations where liquid LP-Gas or has the potential to be trapped. These relief valves provide pressure relief at or in excess of the stated pressure setting, protecting against line or plumbing system failures.

Hydrostatic Relief Valve Features

- Compact design to fit any application
- Non-adjustable, tamper resistant design
- Specially designed internal components to increase flow at discharge



Part Number	Bottom Male Connection	Wrench grip hexagon (mm)	Thread type	PRV - Start to Discharge Setting (PSIG)	Approval	PRV Orifice (mm)
66.1311	1/4-18 NPT	14	X	440	UL	19,00



VS3818VPED4	Pressure Relief Valve 18 bar ø 3/8"
VS3803VPED4	Pressure Relief Valve 3 bar ø 3/8"
VS1418VPED4	Pressure Relief Valve 18 bar ø 1/4"
VS1218VPED4	Pressure Relief Valve 18 bar ø 1/2"
VS1203VPED4	Pressure Relief Valve 3 bar ø 1/2"



Fixed Liquid Level Gauges



66.1072
66.0.290.1072

Special DT length can be ordered apart. An optional instruction plate may be ordered for use with these valves. All these valves incorporate a No. 54 drill size orifice.



66.1161
66.0.290.1161

Remote outgauge



Part Number	Container Connection	Outlet Connection	DT Length
66.1072	1/4" M.NPT	-	12"
66.1116	1/4" M.NPT	-	5.4"
66.1117	1/4" M.NPT	-	6.6"
66.1118	1/4" M.NPT	-	3.8"
66.1119	1/4" M.NPT	-	4.1"
66.1120	1/4" M.NPT	-	5.6"
66.1121	1/4" M.NPT	-	6.9"
66.1204	1/4" M.NPT	-	Without
66.1125	1/4" M.NPT	-	5.2"
66.1161	1/4" NPTF	1/4" SAE Flare	Without

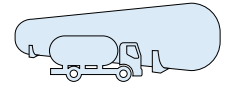

Liquid Withdrawal & Transfer Valves



VL 13
69.0.290.0008
Liquid withdrawal valve.



VL 25
69.0.290.0005
Liquid withdrawal valve to be used with our RL 25 Liquid Withdrawal Valve.



LF 25C
Liquid withdrawal Excess Flow Valve.
Performance: excess flow closes
4.5÷5.5 m³/h (water);
residual flow ≤ 0.050 m³/h (water)
with ΔP +1 bar



RL 15
72.0.090.0004
Liquid Transfer Valve to be used with our VL 13 and VLT 18. It incorporates an excess flow limiter.



RL 25
72.0.090.0025
Liquid Transfer Valve to be used with our VL 25. It incorporates an excess flow limiter.



RRL 16 A-P
Liquid withdrawal valve complete with protection cap.

Part number	Container Connection	Outlet Connection	Wrenching Grip (mm)
69.0008 (VL 13)	3/4" – 14 NPT	3/4" – 14 NPT (plugged)	35
69.0005 (VL 25)	1-1/4" – 14 NPT	M 25x1.5 (plugged)	46
72.0004 (RL 15)	3/4" – 14 NPT	M 30x1.5	28 (square)
72.0025 (RL 25)	M 25x1.5	M 30x1.5	32 (square)
67.0793 (RRL 16)	3/4" – 14 NPT (with*/without* tube threading 3/4" 28UN-2B for dipping)	3/4" – 14 NPT (with plug cap)	34 (square)
69.0040 (LF 25C)	1-1/4" – 14 NPT	3/4" – 14 NPT	46

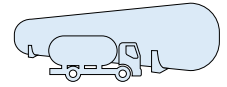

Self-Cleaning Y-Strainers



Designed for flow in one direction to guard against debris in pipelines that could cause damage to pumps, valves or other equipment. Can be installed horizontally or vertically. They are available in three stainless steel mesh sizes. The mesh size equals the number of holes per square inch i.e. the smaller the number the larger the holes.

A shutoff valve installed on the filter basket outlet allows for convenient blow-off cleaning of y-strainer while under pressure.

Self-Cleaning Y-Strainer Features

- Durable ductile iron body with automotive grade powder coat finish
- Rated 600 WOG
- Optional factory installed plug
- Designed for LP-Gas or NH3

Part No.			Blow-Off Plug Size	Inlet & Outlet F8PT
20 Mesh Screen	40 Mesh Screen	80 Mesh Screen		
ME650S/20	ME650S	ME650S/80	1/2"	1/2"
ME651S/20	ME651S	ME651S/80	1/2"	3/4"
ME652S/20	ME652S	ME652S/80	3/4"	1"
ME653S/20	ME653S	ME653S/80	3/4"	1-1/4"
-	ME654S	-	1"	1-1/2"
ME655S/20	ME655S	ME655S/80	1"	2"
-	ME656S	ME656S/80	1-1/4"	3"

To add a factory installed plug use a "P" after the prefix number i.e. ME650SP/20

Pull-away Couplings

Designed to provide a safe way to transfer LP-Gas and NH3 without sacrificing flow. The Flo Kill pull-away Coupling flows both directions and protects against expensive loss of product or equipment damage if a pull-away occurs during a transfer operation. One end of the pull-away coupling should be attached to a fixed or sturdy point. In the event of an excessive amount of pull force, the pull-away coupling will separate and immediately shutoff product flow in both directions.

To reconnect the valve, pressure needs to be relieved from both ends of the line, therefore it is recommended that a safe way to bleed down the line is provided upstream and downstream. After the lines have been depressurized use Marshall Excelsior's re-installation tool (MEP128-6) for 3/4" or slide the male end into the female side and pull the collar back until they lock. After reconnection the line must be tested using Marshall Excelsior Leak Detector to check for leaks before any product is transferred. The pull-away coupling may be used on vapor or liquid lines on transports, delivery trucks, motor fuel containers, fill cabinets and other miscellaneous filling operations.

Note: It is recommended that pull-away couplings be safety tested monthly to confirm that proper separation occurs in the event of a pull-away. Dry air is suggested for a source of pressure during testing.

FloKill pull-away Coupling Features

- Nitrile soft seat provides positive shutoff both upstream and downstream of source
- 100 - 300 lbs of force required for disconnect
- Approximately 100 lbs of force to reconnect
- Large internal bore for increased flow
- Durable plated steel construction
- Rated for LP-Gas & NH3



Part No.		Connection FNPT	OAL Length	Accessory Reassembly Tool
Bracket Style	Lanyard Style			
ME860S-6	ME861S-6	3/4"	6"	MEP128-6
ME860S-8	ME861S-8	1"	6-3/4"	-
ME860S-10	ME861S-10	1-1/4"	7-3/4"	-

Heavy Duty Acme Spanner Wrench



Acme caps sold separately

Aluminum Acme spanner wrench for 1-3/4", 2-1/4", 3-1/4" and 4-1/4" female Acme caps.

Part No.	Length
MEP120B	17-1/2"

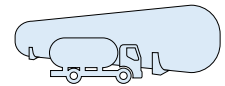

Extractable Level Rod For Tanks

Applications

The extractable level rod for tanks is used to measure the real liquid level inside LPG tanks and other non-toxic liquefied gases.

Installation

This tool must be installed on the top of the tank.
(if the tank has a diameter higher than 1.800 mm it's better to use a level rod for the bottom half of the tank and another one for the upper half).

Characteristics:

- Complete of ball valve DN 25 PN 40
- Head and tube in stainless steel
- Aluminium cap
- Viton gaskets



Part Number	Description
AMN-1.0	Extractable level rod for tanks flanged UNI DN25 PN40 o 1" ANSI 300 RF

Thermodensimeter with Aerometer



PORTABLE DISPOSITIVO TO DETERMINE THE VAPOR TENSION AND GAS WEIGHT OF LIQUEFIED L.P.G.

This type of apparatus enables to determine the vapor tension and the weight of the liquid with one reading thermometric-manometric-densimetric

Components:

- Pressure gauge
- Purging valve
- Safety relief valve 18 bar
- Transparent plastic tube
- N. 6 stainless steel tie rods
- Specific gravity aerometer
- Inlet/outlet valves
- Flexible hose for connection

Part Number	Description
TER-CK/1.0	Thermodensimeter complete of aerometer
AER-CK/1.0	Aerometer for replacement



cavagna group

Advanced solutions for gas control



Ball Valves and Actuators



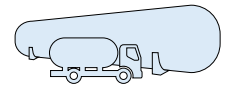

Ball Valves Construction Details

Designed in compliance with ASME/API/EN, Omal ball valves are meant to operated with actuators. For this reason valves are provided with actuator connections and their sealing elements are specifically engineered for a very high number of cycles. OMAL wafer, split wafer and split body ball valves are designed with all the details which set them above many competitors. The "fire safe" version built in compliance with recent, very strict standards and provided with antistatic devices, a complex stem sealing system and all relevant fugitive emission, ATEX and fire safe certifications guarantees best performance and total reliability.

FIRE SAFE: API 6 FA – UNI EN ISO 10497

TA LUFT/FUGITIVE EMISSION Thanks to the special stem double sealing system consisting of a V-pack loaded with Omal springs washer. OMAL valves are certified in compliance with very strict emission standards TA LUFT Tal – 194058 – 001.

ATEX: The body-stem and ball-stem connections are provided with antistatic devices which guarantee power continuity. The valve is in compliance with Directive 94/9 EC – ATEX.

STEM: Being assembled inside, the stem is completely anti blow-out. A double anti-friction washer in PTFE allows the stem to rotate with low friction and the valve to perform flawlessly for a very high number of cycles.

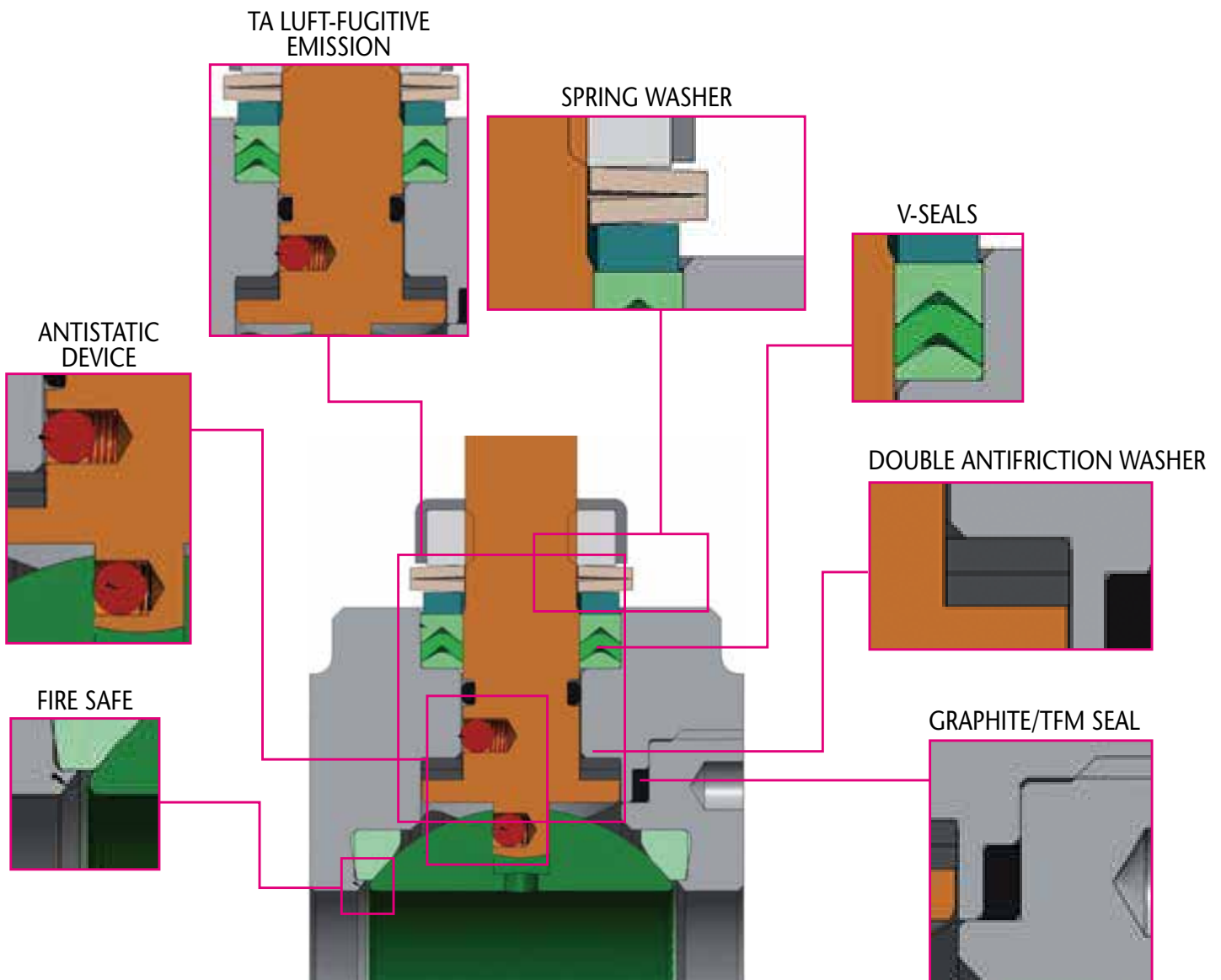

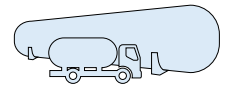

Pneumatic Actuator

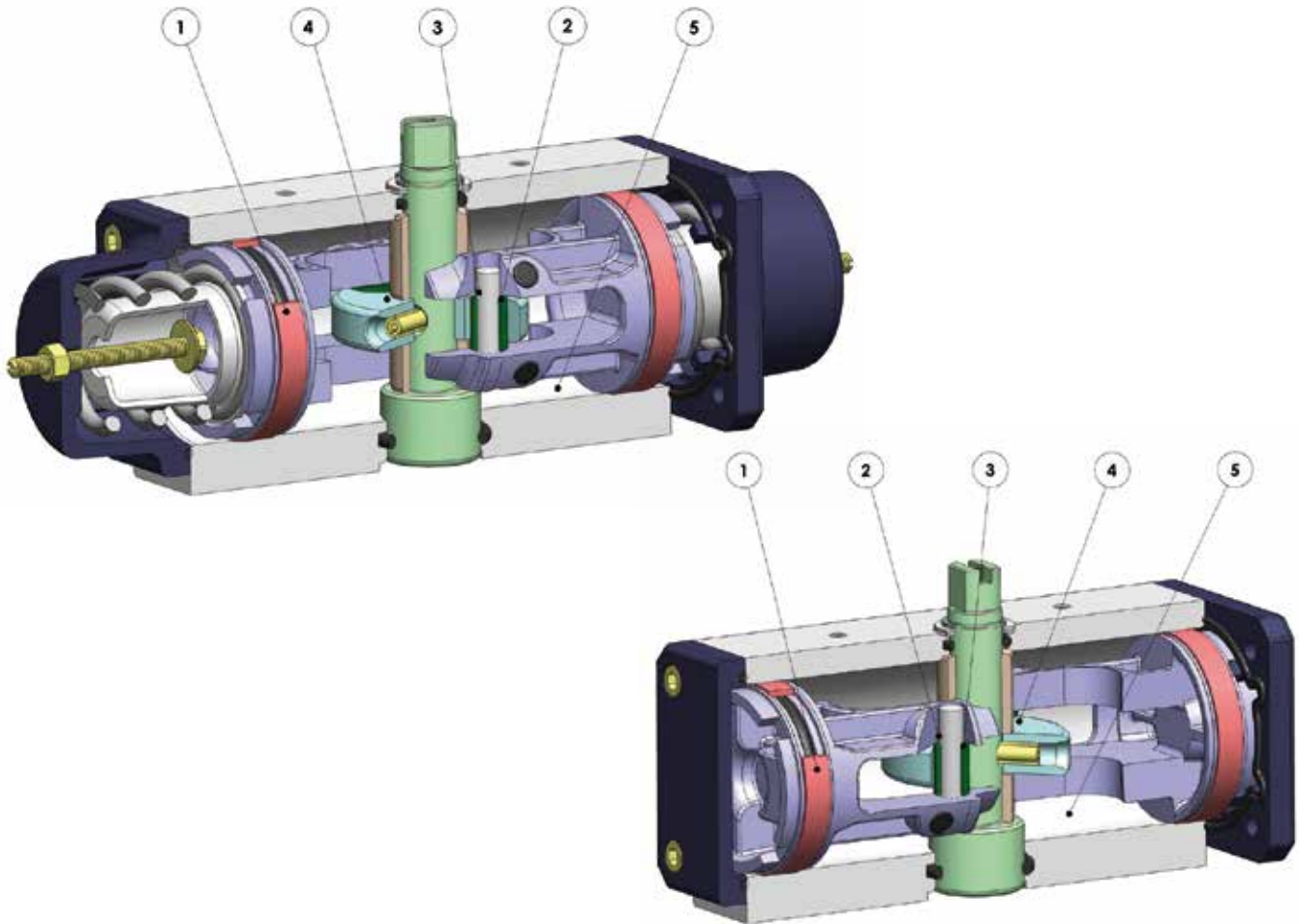

Features and benefits		
1	Energized and self-lubricated strips	Less friction between piston and cylinder It prevents the bonding of the seal to the cylinder even after long periods of inactivity
2	Slots, bushes and pins made by steel with hardness higher than 50 HRC	Higher resistance to the forces inside the actuator
3	Rolling friction between piston and slot	Less friction
4	Scotch joke with rolling friction (transforming rotary motion into linear motion using piston and shaft without teeth/gears)	Reduced friction between piston and shaft with consequently less wear on the relevant parts Empowered Break Away Torque (BTO & BTC) Smaller volume/size than rack and pinion actuators (with the same torque) therefore less space required for installation Less weight than the rack and pinion (-30% kg / Nm), with consequent savings on the construction sizing of the plant/equipment Lower air consumption compared to the rack and pinion (-40% air cm ³ /Nm for Double Acting and -20% air cm ³ /Nm for Spring Return) therefore less load on the compressor or the possibility of using a smaller compressor's size.
5	Rolled cylinder	Less wear of the energized ties thanks to the low roughness of the surface (0.15 micron Ra)
	100% in- house manufacturing process technology	Maximum control and accuracy in all the stages of the manufacturing process
	ATEX Certificate	Installation is allowed in a potential explosive environment
	SIL 3 Certified	Guarantee of the high level of functional safety.

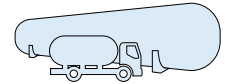

Spring return pneumatic actuator "SR" type



Technical features

Torque from 15 Nm to 4000 Nm. Mounting flange according to DIN/ISO 5211 DIN 3337

F03 - F04 - F05 - F07 - F10 - F12 - F14 - F16.

NAMUR connection for accessories.

Rotation angle 90°

Torque: the return torque depends on spring action only notwithstanding the air supply. The spring is provided in four different sizes (see table).

The code numbers after the letters SR, always correspond to the breakaway torque in Nm by 5,6 bar air supply. The actuator automatic closing takes place in clockwise direction by means of its springs. ATEX version in conformity with directive 94/9/EC. Please add YX at the end of the code for ATEX version.

Working condition

Temperature: from 0°C to +80°C; from -20°C to +80°C with dry air only. (Special versions: high temperature: -20°C +150°C; low temperature: -50°C +60°)

Air supply: 5,6 bar; maximum 8,4 bar.

Operating media: compressed filtered air, not necessarily lubricated.

In case of lubricated air, either non detergent oil or NBR compatible oil, must be used.

Output torque diagram related to rotation angle

OUTPUT TORQUE TABLE (N) - α° = ROTATION ANGLE									
SIZE	α°	2,8 bar ÷ 40 PSI air - spring		3,5 bar ÷ 50 PSI air - spring		4,2 bar ÷ 60 PSI air - spring		5,6 bar ÷ 80 PSI air - spring	
		SR 15	0°	7,5	5,0	9,3	6,3	11,3	7,5
	50°	3,7	3,7	4,7	4,7	5,6	5,6	7,5	7,5
	90°	5,0	7,5	6,3	9,3	7,5	11,3	10,0	15,0
SR 30	0°	15	10	18,8	12,5	22,5	15	30	20
	50°	7,5	7,5	9,4	9,4	11,3	11,3	15	15
	90°	10	15	12,5	18,8	15	22,5	20	30
SR 45	0°	22,5	15	28,1	18,8	33,9	22,5	45	30
	50°	11,1	11,1	13,9	13,9	16,8	16,8	22,5	22,5
	90°	15	22,5	18,8	28,1	22,5	33,9	30	45
SR 60	0°	30	20	37,5	25	45	30	60	40
	50°	15	15	18,8	18,8	22,5	22,5	30	30
	90°	20	30	25	37,5	30	45	40	60
SR 90	0°	45	30	56,4	37,5	67,5	45	90	60
	50°	22,5	22,5	28,2	28,2	33,9	33,9	45	45
	90°	30	45	37,5	56,4	45	67,5	60	90
SR 120	0°	60	40	75	50	90	60	120	80
	50°	30	30	37,5	37,5	45	45	60	60
	90°	40	60	50	75	60	90	80	120
SR 180	0°	90	60	112,5	75	135	90	180	120
	50°	45	45	56,2	56,2	67,5	67,5	90	90
	90°	60	90	75	50	90	135	120	180
SR 240	0°	120	80	150	100	180	120	240	160
	50°	60	60	75	75	90	90	120	120
	90°	80	120	100	150	120	180	160	240
SR 360	0°	180	120	225	150	270	180	360	240
	50°	90	90	112,5	112,5	135	135	180	180
	90°	120	180	150	225	180	270	240	360
SR 480	0°	240	160	300	200	360	240	480	320
	50°	120	120	150	150	180	180	240	240
	90°	160	240	200	300	240	360	320	480
SRN 720	0°	360	240	450	300	540	360	720	480
	50°	180	180	225	225	270	270	360	360
	90°	240	360	300	450	360	540	480	720
SRN 960	0°	480	320	600	400	720	480	960	640
	50°	240	240	300	600	360	360	480	480
	90°	320	480	400	600	480	720	640	960
SR 1440	0°			900	675			1440	180
	50°			450	450			720	720
	90°			675	900			1080	1440
SR 1920	0°	960	640	1200	800	1440	960	1920	1280
	50°	480	480	600	600	720	720	960	960
	90°	640	960	800	1200	960	1440	1280	1920
SR 2880	0°	1440	960	1800	1200	2160	1440	2880	1920
	50°	720	720	900	900	1080	1080	1440	1440
	90°	960	1440	1200	1800	1440	2160	1920	2880
SR 4000	0°	2000	1340	2500	1675	3000	2010	4000	2680
	50°	1000	1000	1250	1250	1500	1500	2000	2000
	90°	1340	2000	1675	2500	2010	3000	2680	4000

Carbon Steel Wafer



STANDARD FEATURES

- No protruding flange ball
- Soft-seat seal (TFM 1600)
- Standard for connecting flanges: EN 1092-1 ed. 2008; ANSI; B16.5
- Operating temperature: from -10°C to +200°C (see temperature pressure diagram)
- Operating pressure: PN16-40; ANSI 150-300
- Intercepted fluid: air, water, gas, petroleum and petrochemical products.
- Antistatic device
- Stem seal: TFM 1600 V-pack
- Additional seal on stem with FKM O-ring
- Anti Blow-out stem
- Actuator connection as per standard ISO 5211
- Closing angle >7°
- Superficial treatment: bluing

SPECIAL FEATURES ON REQUEST

- LF2 carbon steel for low temperature execution (-40 °C)
- For other flange types please contact our sales department
- Heating jacket
- Sealing in: PTFE reinforced with glass (RPTFE), PTFE reinforced with carbon-graphite (CTFE). For other types of materials please contact our sales department
- Cavity filler seat in PTFE
- Mono-directional version with pressure-compensating hole in the ball
- Stainless steel lever
- For special versions in materials different from the standard (body, ball, stem), please contact our sales department.
- Stainless steel Stem nuts and springs
- Superficial treatment: white zinc coating, epoxy coating
- For other coating please contact our sales department

CERTIFICATIONS

- In compliance with European Directive 97/23 EC PED
- In compliance with ATEX 94/9/CE Directive (on request)
- Fugitive Emission UNI EN ISO 15848 (2006)
- TA-LUFT VDI 2440 (2000)
- FIRE SAFE DESIGN: certification on process

ENGINEERING STANDARDS EMPLOYED

- Body thickness in compliance with: ASME B16.34, ASME VIII div.1, EN 12516.
- Materials and rating in compliance with ASME B16.34 for ANSI valves and EN 12516 for PN valves

Stainless Steel Wafer



STANDARD FEATURES

- No protruding flange ball
- Soft-seat seal (TFM 1600)
- Standard for connecting flanges: EN 1092-1 ed. 2008; ANSI B16.5
- Operating temperature: from -40°C to +200°C (see temperature pressure diagram)
- Operating pressure: PN16-40 - ANSI 150-300
- Intercepted fluid: air, water, gas, petroleum and petrochemical products, aggressive fluids
- Antistatic device
- Stem seal: TFM 1600 V-pack
- Additional seal on stem with FKM O-ring
- Anti Blow-out stem
- Actuator connection as per standard ISO 5211
- Closing angle >7°

SPECIAL FEATURES ON REQUEST

- For other flange types please contact our sales department
- Heating jacket
- Sealing in: PTFE reinforced with glass (RPTFE), PTFE reinforced with carbon-graphite (CTFE). For other types of materials please contact our sales department
- PTFE cavity filler seat
- Mono-directional version with pressure-compensating hole in the ball
- Stainless steel lever
- Stainless steel Stem nuts and springs
- For special versions in materials different from the standard (body, ball, stem), please contact our sales department.

CERTIFICATIONS

- In compliance with European Directive 97/23 EC PED
- In compliance with ATEX 94/9/CE Directive (on request)
- Fugitive Emission UNI EN ISO 15848 (2006)
- TA-LUFT VDI 2440 (2000)
- FIRE SAFE DESIGN: certification on process

ENGINEERING STANDARDS EMPLOYED

- Body thickness in compliance with: ASME B16.34, ASME VIII div.1, EN 12516.
- Materials and rating in compliance with ASME B16.34 for ANSI valves and EN 12516 for PN valves

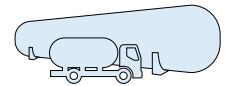

Wafer Series Construction Details

MATERIAL TABLE			Body Stainless Steel	Body Carbon Steel
			V480 / V481	V580 / V581
1	Body	up to DN 40	ASTM A182 F316 / A479 TP.316 (x) (1.4401 / x5CrNiMo17-12-2)	ASTM A105 (*)
		over DN 40	ASTM A351 CF8M (1.4408 / Gx5CrNiMo19-12-2)	
2	Ring nut	up to DN 50	ASTM A182 F316 / A479 TP.316 (1.4401 / x5CrNiMo17-12-2)	ASTM A105 (*)
		over DN 50	ASTM A351 CF8M (1.4408 / Gx5CrNiMo19-12-2)	
3	Ball		ASTM A351 CF8M (1.4408 / Gx5CrNiMo19-12-2)	ASTM A351 CF8(**) (1.4308 / Gx5CrNiMo19-10)
4	Stem		ASTM A182 F316 / A479 TP.316 (1.4401 / x5CrNiMo17-12-2)	ASTM A182 F6A / A479 TP.410 (***) (1.4006 / X12Cr13)
5	Seats			TFM 1600
6	Ring nut gasket			TFM 1600
7	Bottom sealing			TFM 1600
8	Chevron rings			TFM 1600
9	Stem o'ring			FKM
10	Gland nut ring		ASTM A182 F304 / A479 TP.304 (1.4301 / X5CrNi18-10)	Carbon Steel ZINCATO-galvanized (x)
11	Nut holder			AISI 304
12	Stem nut (x)			UNI 3740-1 6S ZINCATO-galvanized (x)
13	Spring washer (xx)			50CrV4 ZINCATO - galvanized (xx)
14	Antistatic device			ASTM A182 F316 / A479 TP.316
15	Lock nut			UNI 3740-1 6S ZINCATO-galvanized
16	Holder screw			A2 UNI EN ISO 3506-1
17	Holder			Carbon Steel ZINCATO-galvanized
18	Lever			Fe 37 ZINCATO galvanized

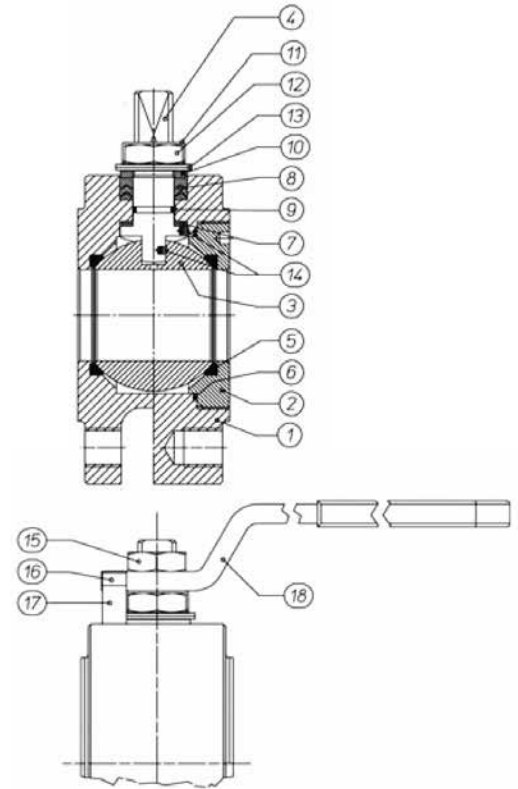
AVAILABLE ON REQUEST:

(*) A350LF2 (**) A351 CF8M (***) 316 S.S. (x) 304 s.s. (xx) 301 s.s.

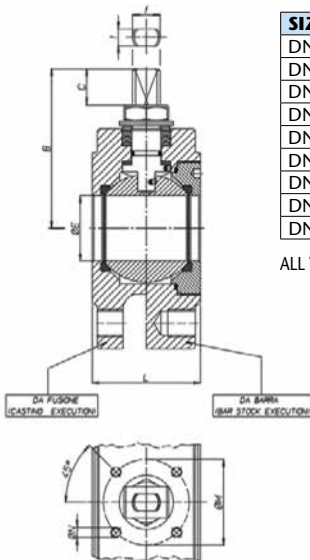

SIZE	ØE	L	B	C	ATT.ISO	ØM	ØN	F/T
DN15	13	36	52	10	F03	36	M5	10/6
DN20	19	39	55	10	F03	36	M5	10/6
DN25	25	43	68	15	F04	42	M5	12/8
DN32	32	51 o 54	73	15	F04	42	M5	12/8
DN40	38	63	93	21	F05	50	M6	16/10
DN50	51	83	102	21	F05	50	M6	16/10
DN65	64	107	130,5	28	F07	70	M8	22/14
DN80	76	120	137,5	28	F07	70	M8	22/14
DN100	95	152	166	35	F10	102	M10	30/18

ALL VALVES HAVE NO PROTRUDING BALL EXCEPT DN32 (FACE TO FACE 51 mm)

	DN15	DN20	DN25	DN32	DN40	DN50	DN65	DN80	DN100
H	70	73	86	91	108	117	142	149	191
Y	140	140	150	150	275	275	350	350	450

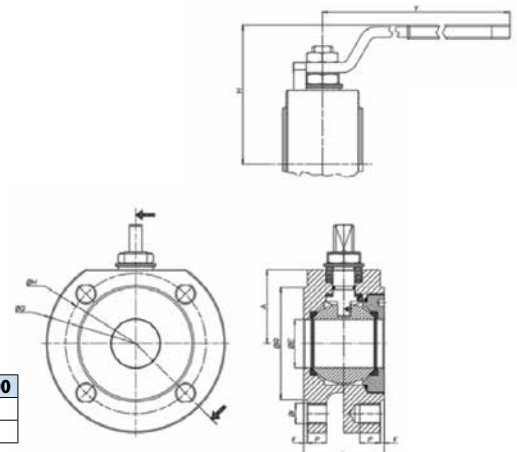

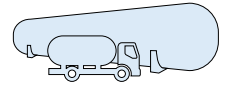

Wafer Series Construction Details

BARE SHAFT VALVE CODE (V _ _)
LEVER OPERATED VALVE CODE (L _ _)

	Body Stainless steel	Body Carbon steel	SIZE	PN	A	ØG	ØR	F	ØH	N°FORI	ØI	P	KG.	L
BAR STOCK EXECUTION	L/V480B0604	L/V580A0604	DN15	PN16-40	32	90	45	1	65	4	M12	14	1,4	36
	L/V480BC604	L/V580AC604	DN15	ANSI 150	32	90	45	1	60,5	4	1/2"UNC	14	1,4	36
	L/V481BC604	L/V581C0604	DN15	ANSI 300	34	90	45	1	66,7	4	1/2"UNC	14	1,4	36
	L/V480B0605	L/V580A0605	DN20	PN16-40	35	100	58	2	75	4	M12	14	1,8	39
	L/V480BC605	L/V580AC605	DN20	ANSI 150	35	100	52	1,6	69,8	4	1/2"UNC	14	1,8	39
	L/V481BC605	L/V581AC605	DN20	ANSI 300	39	110	52	1,6	82,5	4	5/8"UNC	14	2,1	39
	L/V480B0606	L/V580A0606	DN25	PN16-40	42	110	68	2	85	4	M12	16	2,5	43
	L/V480BC606	L/V580AC606	DN25	ANSI 150	42	110	60	1,6	79,4	4	1/2"UNC	16	2,5	43
	L/V481BC606	L/V581AC606	DN25	ANSI 300	45	120	60	1,6	88,9	4	5/8"UNC	16	2,9	43
	L/V480B0607	L/V580A0607	DN32	PN16-40	47	130	78	2	100	4	M16	20	4,0	51
	L/V480B0607S	L/V580A0607S	DN32	PN16-40	47	130	78	2	100	4	M16	20	4,3	54
	L/V480BC607	L/V580AC607	DN32	ANSI 150	47	118	72	1,6	88,9	4	1/2"UNC	20	3,8	54
	L/V481BC607	L/V581AC607	DN32	ANSI 300	47	130	72	1,6	98,4	4	5/8"UNC	20	4,3	54
	L/V480B0608	L/V580A0608	DN40	PN16-40	58	140	88	3	110	4	M16	20	5,9	63
	L/V480BC608	L/V580AC608	DN40	ANSI 150	58	127	82	1,6	98,4	4	1/2"UNC	20	5,1	63
	L/V481BC608	L/V581AC608	DN40	ANSI 300	58	150	82	1,6	114,3	4	3/4"UNC	25	7,0	63
	L/V480B0609	L/V580A0609	DN50	PN16-40	67	150	102	3	125	4	M16	20	8,9	83
	L/V480BC609	L/V580AC609	DN50	ANSI 150	67	150	102	1,6	120,6	4	5/8"UNC	20	9,1	83
	L/V481BC609	L/V581AC609	DN50	ANSI 300	67	160	102	1,6	127,0	8	5/8"UNC	20	10,4	83
	L/V480B0610	L/V580A0610	DN65	PN16	83	178	122	3	145	4	M16	20	16,2	107
	L/V481B0610	L/V581A0610	DN65	PN25-40	83	178	122	3	145	8	M16	20	16,1	107
	L/V480BC610	L/V580AC610	DN65	ANSI 150	83	178	122	1,6	139,7	4	5/8"UNC	20	16,4	107
	L/V481BC610	L/V581AC610	DN65	ANSI 300	89	190	122	1,6	149,2	8	3/4"UNC	25	18,6	107
	L/V480B0611	L/V580A0611	DN80	PN16-40	90	190	138	3	160	8	M16	20	20,0	120
	L/V480BC611	L/V580AC611	DN80	ANSI 150	90	190	135	1,6	152,5	4	5/8"UNC	20	20,4	120
	L/V481BC611	L/V581AC611	DN80	ANSI 300	96	205	138	1,6	168,3	8	3/4"UNC	25	24,0	120
	L/V480B0612	L/V580A0612	DN100	PN16	101	220	160	3	180	8	M16	20	34,0	152
	L/V481B0612	L/V581A0612	DN100	PN25-40	105	235	162	3	190	8	M20	25	39,1	152
	L/V480BC612	L/V580AC612	DN100	ANSI 150	101	220	160	1,6	190,5	8	5/8"UNC	20	34,0	152
	L/V481BC612	L/V581AC612	DN100	ANSI 300	115	250	160	1,6	200,0	8	3/4"UNC	25	46,4	152
CASTED	L/V480E0609		DN50	PN16	67	165	102	3	125	4	M16	15	6,3	83
	L/V480EC609		DN50	ANSI 150	67	150	102	1,6	120,6	4	5/8"UNC	17,4	5,9	83
	L/V481E0610		DN65	PN16	83	185	122	3	145	4	M16	15	9,9	107
	L/V480EC610		DN65	ANSI 150	83	178	122	1,6	139,7	4	5/8"UNC	20,6	10,6	107
	L/V480E0611		DN80	PN16	90	200	138	3	160	8	M16	17	12,6	120
	L/V480EC611		DN80	ANSI 150	90	190	135	1,6	152,5	4	5/8"UNC	22,2	13,1	120
	L/V480E0612		DN100	PN16	101	220	160	3	180	8	M16	17	20,0	152
	L/V480EC612		DN100	ANSI 150	101	228	160	1,6	190,5	8	5/8"UNC	22,2	21,5	152



All valves have no protruding ball except DN32 (Face to face 51 mm)

PN 16-40 Wafer Series Spring Return Pneumatic Actuator

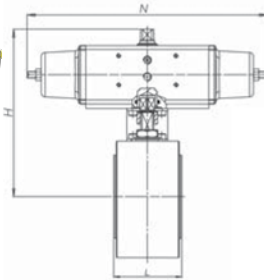

EXECUTION FROM SOLID BAR

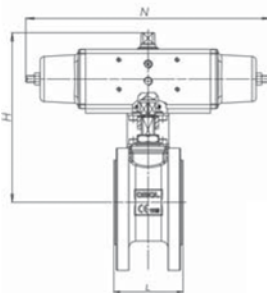

EXECUTION FROM CASTING

PN 16-40 Wafer Serie Spring Return Pneumatic Actuator									
Body Stainless Steel	Body/Carbon Steel	Actuator	Connecting Kit	SIZE	PN	N	H	Kg	L
S480BH064	S580AH064	SR015401S	KCF033761	DN15	16	221	152,4	3,0	36
S481BH064	S581AH064	SR003401S	KCF043767		25-40	240	162,4	3,4	
S480BH065	S580AH065	SR030402S	KCF043767	DN20	16-40	240	165,4	4,2	39
S480BH066	S580AH066	SR030402S	KCF043807	DN25	16-40	240	172,4	4,8	43
S480BH067	S580AH067	SR045401S	KCF053768	DN32	16-40	294	184,5	7,0	51
S480BH067S	S580AH067S							7,3	
S480BH068	S580AH068	SR060401S	KCF053764	DN40	16-40	320	224,4	11,1	63
S480BH069	S580AH069	SR090401S	KCF073769	DN50	16	357	243	13,5	83
S481BH069	S581AH069	SR120401S	KCF073765		25-40	372	253,4	15,7	
S480BH070	S580AH070	SR120401S	KCF073765	DN65	16	372	279,4	22,7	107
S481BH070	S581AH070	SR180401S	KCF103770		25-40	436	291	25,3	
S480BH071	S580AH071	SR180401S	KCF103770	DN80	16	436	298	30,0	120
S481BH071	S581AH071	SR240401S	KCF103770		25-40	456	310	30,8	
S480BH072	S580AH072	SR360401S	KCF123778	DN100	16	566	359	51,8	152
S481BH072	S581AH072	SR480401S	KCF123771		25-40	602	371,2	58,2	
S480EH069	-	SR090401S	KCF073769	DN50	16	357	243	10,9	83
S480EH070	-	SR120401S	KCF073765	DN65	16	372	279,4	16,4	107
S480EH071	-	SR180401S	KCF103770	DN80	16	436	298	22,6	120
S480EH072	-	SR360401S	KCF123778	DN100	16	566	359	37,8	152

BAR STOCK EXECUTION

CASTED

ANSI 150-300 Wafer Series Spring Return Pneumatic Actuator

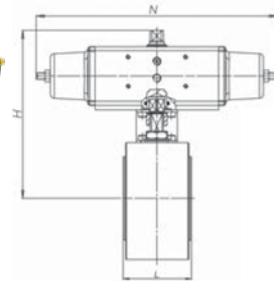

EXECUTION FROM SOLID BAR

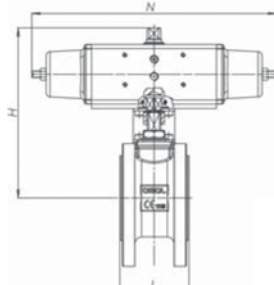

EXECUTION FROM CASTING

ANSI 150-300 Wafer Serie Spring Return Pneumatic Actuator									
Body Stainless Steel	Body/Carbon Steel	Actuator	Connecting Kit	SIZE	CL	N	H	Kg	L
S480BHC64	S580AHC64	SR015401S	KCF033761	DN15	Ansi 150	221	152,4	3,0	36
S481BHC64	S581AHC64	SR003401S	KCF043888		Ansi 300	240	164,4	3,4	
S480BHC65	S580AHC65	SR030402S	KCF043767	DN20	Ansi 150	240	165,4	4,2	39
S481BHC65	S581AHC65				Ansi 300	240	169,4	4,5	
S480BHC66	S580AHC66	SR030402S	KCF043807	DN25	Ansi 150	240	172,4	4,8	43
S481BHC66	S581AHC66				Ansi 300	240	175,4	5,2	
S480BHC67	S580AHC67	SR045401S	KCF053768	DN32	Ansi 150	294	184,5	6,8	54
S481BHC67	S581AHC67				Ansi 300	294	184,5	7,3	
S480BHC68	S580AHC68	SR060401S	KCF053764	DN40	Ansi 150	320	224,4	10,9	63
S481BHC68	S581AHC68				Ansi 300	320	224,4	12,3	
S480BHC69	S580AHC69	SR090401S	KCF073769	DN50	Ansi 150	357	243	13,7	83
S481BHC69	S581AHC69	SR120401S	KCF073891		Ansi 300	372	259,4	17,1	
S480BHC70	S580AHC70	SR120401S	KCF073765	DN65	Ansi 150	372	279,4	22,9	107
S481BHC70	S581AHC70	SR180401S	KCF103892		Ansi 300	436	297	27,7	
S480BHC71	S580AHC71	SR180401S	KCF103770	DN80	Ansi 150	436	298	30,4	120
S481BHC71	S581AHC71	SR240401S	KCF103892		Ansi 300	456	316	34,8	
S480BHC72	S580AHC72	SR360401S	KCF123778	DN100	Ansi 150	566	359	52,2	152
S481BHC72	S581AHC72	SR480401S	KCF123893		Ansi 300	602	381,2	65,2	
S480EHC69	-	SR090401S	KCF073769	DN50	Ansi 150	357	243	10,4	83
S480EHC70	-	SR120401S	KCF073765	DN65	Ansi 150	372	279,4	17,1	107
S480EHC71	-	SR180401S	KCF103770	DN80	Ansi 150	436	298	23,1	120
S480EHC72	-	SR360401S	KCF123778	DN100	Ansi 150	566	359	39,3	152

BAR STOCK EXECUTION

CASTED

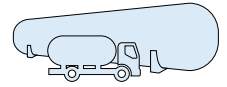

Carbon Steel Split Wafer



STANDARD FEATURES

- No protruding flange ball
- Soft-seat seal (TFM 1600)
- Standard for connecting flanges: EN 1092-1 ed. 2008; ANSI; B16.5
- Operating temperature: from -10°C to +200°C (see temperature pressure diagram)
- Operating pressure: PN16-40; ANSI 150-300
- Intercepted fluid: air, water, gas, petroleum and petrochemical products.
- Antistatic device
- Stem seal: TFM 1600 V-pack
- Additional seal on stem with FKM O-ring
- Anti Blow-out stem
- Actuator connection as per standard ISO 5211
- Closing angle >7°
- Superficial treatment: blueing

SPECIAL FEATURES ON REQUEST

- LF2 carbon steel for low temperature execution (-40 °C)
- For other flange types please contact our sales department
- Heating sleeve
- Sealing in: PTFE reinforced with glass (RPTFE), PTFE reinforced with carbon-graphite (CTFE). For other types of materials please contact our sales department
- Cavity filler seat in PTFE
- Mono-directional version with pressure-compensating hole in the ball
- Stainless steel lever
- For special versions in materials different from the standard (body, ball, stem), please contact our sales department.
- Stainless steel Stem nuts and springs
- Superficial treatment: white zinc coating ,epoxy coating
- For other coating please contact our sales department

CERTIFICATIONS

- In compliance with European Directive 97/23 EC PED
- In compliance with ATEX 94/9/CE Directive (on request)
- Fugitive Emission UNI EN ISO 15848 (2006)
- TA-LUFT VDI 2440 (2000)
- FIRE SAFE DESIGN: in the process of certification

ENGINEERING STANDARDS EMPLOYED

- Body thickness in compliance with: ASME B16.34, ASME VIII div.1, EN 12516.
- Materials and rating in compliance with ASME B16.34 for
- ANSI valves and EN 12516 for PN valves

Stainless Steel Split Wafer



STANDARD FEATURES

- No protruding flange ball
- Soft-seat seal (TFM 1600)
- Standard for connecting flanges: EN 1092-1 ed. 2008; ANSI; B16.5
- Operating temperature: from -40°C to +200°C (see temperature pressure diagram)
- Operating pressure: PN16-40 - ANSI 150-300
- Intercepted fluid: air, water, gas, petroleum and petrochemical products, aggressive fluids
- Antistatic device
- Stem seal: TFM 1600 V-pack
- Additional seal on stem with FKM O-ring
- Anti Blow-out stem
- Actuator connection as per standard ISO 5211
- Closing angle >7°

SPECIAL FEATURES ON REQUEST

- For other flange types please contact our sales department
- Heating jacket
- Sealing in: PTFE reinforced with glass (RPTFE), PTFE reinforced with carbon-graphite (CTFE). For other types of materials please contact our sales department
- PTFE cavity filler seat
- Mono-directional version with pressure-compensating hole in the ball
- Stainless steel lever
- Stainless steel Stem nuts and springs
- For special versions in materials different from the standard (body, ball, stem), please contact our sales department.

CERTIFICATIONS

- In compliance with European Directive 97/23 EC PED
- In compliance with ATEX 94/9/CE Directive (on request)
- Fugitive Emission UNI EN ISO 15848 (2006)
- TA-LUFT VDI 2440 (2000)
- FIRE SAFE DESIGN: certification on process

ENGINEERING STANDARDS EMPLOYED

- Body thickness in compliance with: ASME B16.34, ASME VIII div.1, EN 12516.
- Materials and rating in compliance with ASME B16.34 for
- ANSI valves and EN 12516 for PN valves

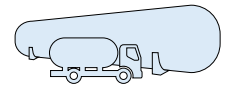

Split Wafer Series Construction Details

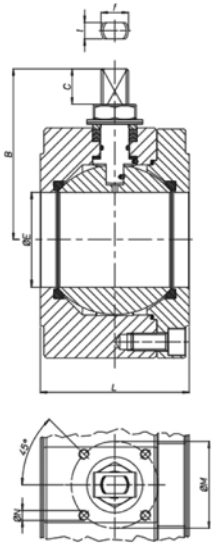

SIZE	ØE	L	B	C	ATT.ISO	ØM	ØN	f/t
DN50	51	90	102	21	F05	50	M6	10/6
DN65	64	107	130,5	28	F07	70	M8	22/14
DN80	76	120	68	28	F07	70	M8	22/14
DN100	102	167	73	35	F10	102	M8	30/18
DN125	118	180	93	35	F10	102	M10	30/18
DN150	152	240	102	40,5	F14	140	M10	45/30
DN200	203	314	130,5	44,8	F14	140	M16	52/35

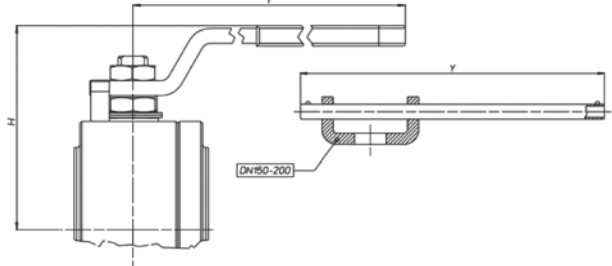
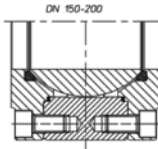

	DN50	DN65	DN80	DN100	DN125	DN150	DN200
H	117	142	149	198	208	215	295
Y	275	350	350	450	450	800	800

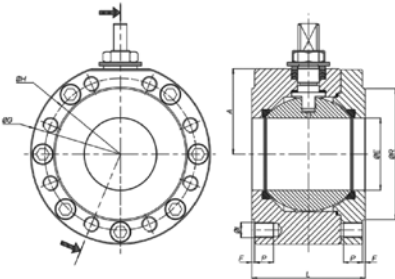

BARE SHAFT VALVE CODE (V_) / LEVER OPERATED VALVE CODE (L_)

Body Stainless steel	Body Carbon steel	SIZE	PN/ANSI	A	ØG	ØR	F	ØH	N° FORI	ØI	P	KG.	L
L/V485B0609	L/V585A0609	DN50	PN16-40	67	150	102	3	125	4	M16	20	9,7	90
L/V485BC609	L/V585AC609	DN50	ANSI 150	67	150	92	1,6	120,6	4	5/8"UNC	20	9,7	90
L/V486BC609	L/V586AC609	DN50	ANSI 300	73	150	92	1,6	127,0	8	5/8"UNC	20	9,7	90
L/V485B0610	L/V585A0610	DN65	PN16	83	178	122	3	145	4	M16	20	16,4	107
L/V486B0610	L/V586A0610	DN65	PN25-40	83	178	122	3	145	8	M16	20	16,1	107
L/V485BC610	L/V585AC610	DN65	ANSI 150	83	178	104,7	1,6	139,7	4	5/8"UNC	20	16,5	107
L/V486B0610	L/V586A0610	DN65	ANSI 300	89	190	104,7	1,6	149,2	8	3/4"UNC	25	18,7	107
L/V485B0611	L/V585A0611	DN80	PN16-40	90	190	138	3	160	8	M16	20	20,2	120
L/V485BC611	L/V585AC611	DN80	ANSI 150	90	190	127	1,6	152,4	4	5/8"UNC	20	20,7	120
L/V486BC611	L/V586AC611	DN80	ANSI 300	90	205	127	1,6	168,3	8	3/4"UNC	25	24,0	120
L/V485B0612	L/V585A0612	DN100	PN16	107	235	158	3	180	8	M16	20	40,4	167
L/V486B0612	L/V586A0612	DN100	PN25-40	107	235	162	3	190	8	M20	25	40,5	167
L/V485BC612	L/V585AC612	DN100	ANSI 150	107	235	157,2	1,6	190,5	8	5/8"UNC	20	40,7	167
L/V486BC612	L/V586AC612	DN100	ANSI 300	115	250	157,2	1,6	200,0	8	3/4"UNC	25	48,2	167
L/V485B0613	L/V585A0613	DN125	PN16	117	250	188	3	210	8	M16	25	48,2	180
L/V486B0613	L/V586A0613	DN125	PN25-40	125	270	188	3	220	8	M24	30	57,9	180
L/V485BC613	L/V585AC613	DN125	ANSI 150	117	250	185,2	1,6	216	8	3/4"UNC	25	48,3	180
L/V485B0614	L/V585A0614	DN150	PN16	154	332	212	3	240	8	M20	25	109,3	240
L/V485BC614	L/V585AC614	DN150	ANSI 150	154	332	216	1,6	241,3	8	3/4"UNC	25	110,3	240
L/V485B0615	L/V585A0615	DN200	PN16	188	396	268	3	295	12	M20	30	191,8	314
L/V485BC615	L/V585AC615	DN200	ANSI 150	188	396	269,8	1,6	298,4	8	3/4"UNC	25	193,7	314

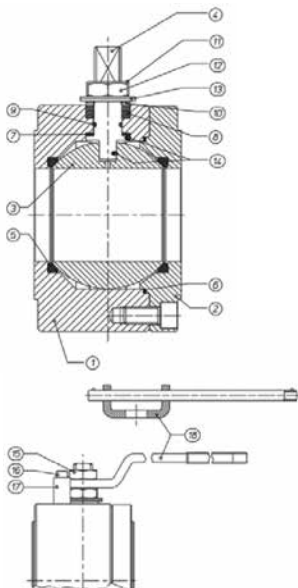

MATERIAL TABLE	Body Stainless Steel	Body Carbon Steel
	V485 / V486	V585 / V586
1 Body	ASTM A182 F316 / A479 TP.316 (x) (1.4401 / X5CrNiMo17-12-2)	ASTM A105 (*)
2 Ring nut		ASTM A105 (*)
3 Ball	ASTM A351 CF8M (1.4408 / GX5CrNiMo19-12-2)	ASTM A351 CF8(**) (1) (1.4308 / GX5CrNiMo19-10)
4 Stem	ASTM A182 F316 / A479 TP.316 (1.4401 / X5CrNiMo17-12-2)	
5 Seats	TFM 1600	
6 Ring nut gasket	GRAFITE / GRAPHITE	
7 Bottom sealing	TFM 1600	
8 Chevron rings	TFM 1600	
9 Stem o'ring	TFM 1600	
10 Gland nut ring	ASTM A182 F304 / A479 TP.304 (1.4301 / X5CrNi18-10)	Carbon Steel ZINCATO galvanized (x) (3)
11 Nut holder	AISI 304	
12 Stem nut	UNI 3740-1 6S ZINCATO-galvanized (x)	
13 Spring washer	50CrV4 ZINCATO - galvanized (xx)	
14 Antistatic device	ASTM A182 F316 / A479 TP.316	
19 Body ring nut screw	A2-70 UNI 3740	8,8 uni 3740 - galvanized
15 Lock nut (x)	UNI 3740-1 6S ZINCATO-galvanized	
16 Holder screw	A2 UNI EN ISO 3506-1	
17 Holder	Carbon Steel ZINCATO-galvanized	
18 Lever (x)	Fe 37 ZINCATO galvanized	

AVAILABLE ON REQUEST:

- (*) A350LF2
- (**) A351 CF8M
- (***) 316 S.S.
- (x) 304 s.s.
- (xx) 301 s.s.
- (1) for DN 100-125-150-200 only A351-CF8M
- (2) for DN 150-200 only 316 s.s.
- (3) for DN 150-200 only 304 s.s.

Carbon Steel Split Body



STANDARD FEATURES

- Floating ball, full bore
- Soft-seat seal TFM 1600
- Standard for connecting flanges: EN 1092-1 ed. 2008; ANSI B16.5
- Operating temperature see temperature pressure diagram
- Pressure class: PN16-40; ANSI 150-300
- Intercepted fluid: air, water, gas, petroleum and petrochemical products.
- Antistatic device EN12662-2
- Stem seal: TFM 1600 V-ring packing
- Additional seal on stem with FKM O-ring
- Anti Blow-out stem
- Actuator connection as per standard ISO 5211
- Closing angle >7°
- Superficial treatment: blueing

SPECIAL FEATURES ON REQUEST

- LF2 carbon steel for low temperature execution (-40 C°)
- For other flange types please contact our sales department.
- Sealing in: PTFE reinforced with glass (RPTFE-GF), PTFE reinforced with carbon-graphite (RPTFE-CF). For other types of materials please contact our sales department
- Cavity filler seatin PTFE
- Mono-directional version with pressure-compensating hole in the ball
- Stainless steel lever
- For special versions in materials different from the standard (body, ball, stem), please contact our sales department.
- Stainless steel Stem nuts and springs
- Superficial treatment: white zinc coating ,epoxy coating
- For other coating please contact our sales department

CERTIFICATIONS

- In compliance with European Directive 97/23 EC PED
- In compliance with ATEX 94/9/CE Directive (on request)
- Fugitive Emission UNI EN ISO 15848 (2006)
- TA-LUFT VDI 2440 (2000)
- FIRE SAFE: API 607:2005/ISO 10497:2010 - API6FA:1999
- API 6D: certificato n°6D-1007 only for valves with ANSI face to face

ENGINEERING STANDARDS

- Body thickness in compliance with: ASME B16.34, ASME VIII div.1, EN 12516.
- **API 6D**
- Materials and rating in compliance with ASME B16.34 for ANSI valves and EN 12516 for PN valves

Stainless Steel Split Body



STANDARD FEATURES

- Floating ball, full bore
- Soft-seat seal TFM 1600
- Standard for connecting flanges: EN 1092-1 ed. 2008; ANSI B16.5
- Operating temperature see temperature pressure diagram
- Pressure class: PN16-40 - ANSI 150-300
- Intercepted fluid: air, water, gas, petroleum and petrochemical products, aggressive fluids
- Antistatic device EN12662-2
- Stem seal: TFM 1600 V-ring packing
- Additional seal on stem with FKM O-ring
- Anti Blow-out stem
- Actuator connection as per standard ISO 5211
- Closing angle >7°

SPECIAL FEATURES ON REQUEST

- For other flange types please contact our sales department.
- Sealing in: PTFE reinforced with glass (RPTFE-GF), PTFE reinforced with carbon-graphite (RPTFE-CF). For other types of materials please contact our sales department
- PTFE cavity filler seat
- Mono-directional version with pressure-relief hole in the ball
- Stainless steel lever
- Stainless steel Stem nuts and springs
- For special versions in materials different from the standard (body, ball, stem), please contact our sales department.

CERTIFICATIONS

- In compliance with European Directive 97/23 EC PED
- In compliance with ATEX 94/9/CE Directive (on request)
- Fugitive Emission UNI EN ISO 15848:2006
- TA-LUFT VDI 2440:2000
- FIRE SAFE: API 607:2005/ISO 10497:2010 - API6FA:1999
- API 6D: certificate no 6D-1007 only for valves with ANSI face to face

ENGINEERING STANDARDS

- Body thickness in compliance with: ASME B16.34, ASME VIII div.1, EN 12516
- **API 6D**
- Materials and rating in compliance with ASME B16.34 for ANSI valves and EN 12516 for PN valves

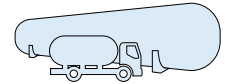

Split Body Series Construction Details

MATERIALS	Stainless steel body	Carbon steel body
DESCRIPTION	V470 / V471	V570 / V471
1 Body	ASTM A182 F316 / A479 TP.316 (x)	ASTM A105 (*)
2 Connector	(1.4401 / X5CrNiMo17-12-2)	
3 Ball	ASTM A351 CF8M (1.4408 / Gx5CrNiMo19-12-2)	ASTM A351 CF8 (**) (1.4308 / GX5CrNi19-10)
4 Stem	ASTM A182 F316/A479 TP.316/A564-TP.630 (17-4 PH) (1.4401 / X5CrNiMo17-12-2)	ASTM A182 F6A / A479 TP.410 (***) (1.4006 / X12Cr13)
5 Seats		TFM 1600 (•)
6 Body gasket		GRAFOIL
7 Bottom sealing		TFM 1600 (•)
8 Chevron rings		TFM 1600 (•)
9 Stem o'ring		FKM (•)
10 Gland nut ring	ASTM A182 F304 / A479 TP.304 (1.4301 / X5CrNi18-10) / 174 PH (AISI 630)	Zinc coated carbon steel (x) (1)
11 Nut holder		AISI 304
12 Stem nut		UNI 3740-1 6S ZINCATO - galvanized (x)
13 Spring washer		50CrV4 ZINCATO - galvanized (xx)
14 Antistatic device		ASTM A182 F316 / A479 TP.316
15 Stud bolt	ASTM A193-B8	ASTM A193-B7
16 Nut	ASTM A194-Gr.8	ASTM A194-2H
17 Lock nut (x)		UNI 3740-1 6S ZINCATO - galvanized (x)
18 Holder screw		A2 UNI EN ISO 3506-1
19 Holder		Zinc coated carbon steel (x)
20 Lever (x)		Fe 37 ZINCATO - galvanized

AVAILABLE ON REQUEST:

- (*) A350LF2 (x) 304 s.s.
- (**) A351 CF8M (xx) 301 s.s.
- (***) 316 S.S./17-4PH
- (•) Other materials available on request

- (1): per DN150-200 disponibile solo on 304 s.s.
- (1): for DN150-200 only 304 s.s.

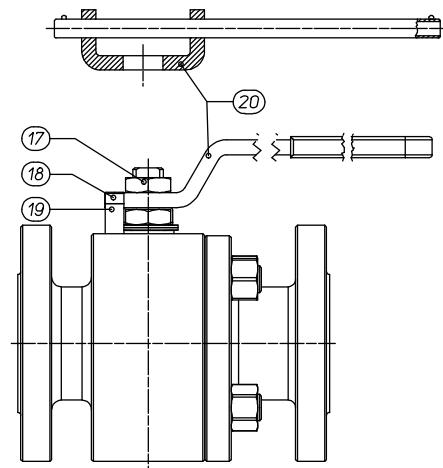
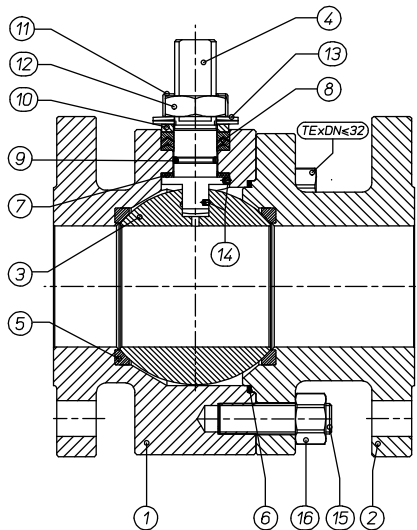

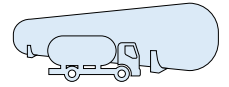

Split Body Series Construction Details

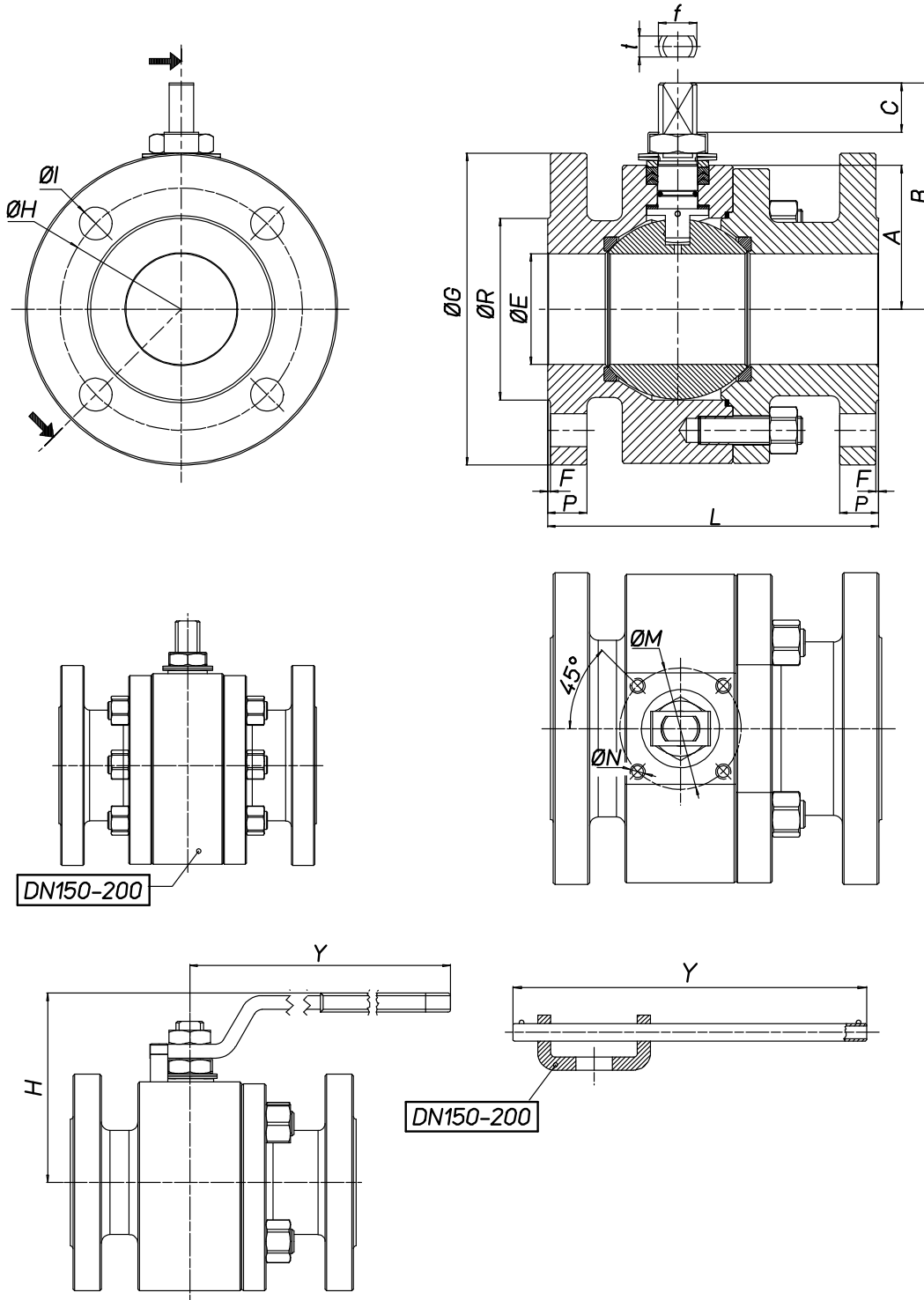

	DN15	DN20	DN25	DN32	DN40	DN50	DN65	DN80	DN100	DN125	DN150	DN200
H	70	73	86	91	108	117	142	149	198	208	274	321
Y	140	140	150	150	275	275	350	350	450	450	800	800

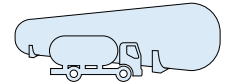

Split Body Series Construction Details

BARE SHAFT VALVE CODE (V_)
LEVER OPERATED VALVE CODE (L_)

Body Stainless steel	Body Carbon steel	SIZE	ØE	PN/ANSI	A	B	C	ATT. ISO	ØM	ØN	f/t	ØG	ØR	F	P	ØH	N° FORI	ØI	KG.	L
L/V470B0604	L/V570A0604	DN15	13	PN16-40	32	52	10	F03	36	M5	10/6	95	45	2	16	65	4	14	2,8	115 (1)
L/V470BD604	L/V570AD604	DN15	13	ansi150	32	52	10	F03	36	M5	10/6	90	35	1,6	11,2	60,3	4	16	2,4	108 (3)
L/V471BD604	L/V571AD604	DN15	13	ansi300	32	52	10	F03	36	M5	10/6	95	35	1,6	14,5	66,7	4	16	2,7	140 (3)
L/V470B0605	L/V570A0605	DN20	19	PN16-40	35	55	10	F03	36	M5	10/6	105	58	2	18	75	4	14	3,6	120 (1)
L/V470BD605	L/V570AD605	DN20	19	ansi150	35	55	10	F03	36	M5	10/6	100	43	1,6	13	69,9	4	16	2,9	117 (3)
L/V471BD605	L/V571AD605	DN20	19	ansi300	35	55	10	F03	36	M5	10/6	115	43	1,6	16,6	82,6	4	19	3,9	152 (3)
L/V470B0606	L/V570A0606	DN25	25	PN16-40	42	68	15	F04	42	M5	12/8	115	68	2	18	85	4	14	5,2	125 (1)
L/V470BD606	L/V570AD606	DN25	25	ansi150	42	68	15	F04	42	M5	12/8	110	51	1,6	14,5	79,4	4	16	6,6	127 (3)
L/V471BD606	L/V571AD606	DN25	25	ansi300	42	68	15	F04	42	M5	12/8	125	51	1,6	18	88,9	4	19	5,9	165 (3)
L/V470B0607	L/V570A0607	DN32	32	PN16-40	47	73	15	F04	42	M5	12/8	140	78	2	18	100	4	18	7,6	130 (1)
L/V470BD607	L/V570AD607	DN32	32	ansi150	47	73	15	F04	42	M5	12/8	115	63,5	1,6	16	89	4	16	6,2	140 (3)
L/V471BD607	L/V571AD607	DN32	32	ansi300	47	73	15	F04	42	M5	12/8	135	63,5	1,6	19,5	98,4	4	19	8,7	178 (3)
L/V470B0608	L/V570A0608	DN40	38	PN16-40	58	93	21	F05	50	M6	16/10	150	88	3	18	110	4	18	10	140 (1)
L/V470BD608	L/V570AD608	DN40	38	ansi150	58	93	21	F05	50	M6	16/10	125	73	1,6	18	98,4	4	16	9,4	165 (3)
L/V471BD608	L/V571AD608	DN40	38	ansi300	58	93	21	F05	50	M6	16/10	155	73	1,6	21	114,3	4	22	12	190 (3)
L/V470B0609	L/V570A0609	DN50	51	PN16-40	67	102	21	F05	50	M6	16/10	165	102	3	20	125	4	18	14,3	150 (1)
L/V470BD609	L/V570AD609	DN50	51	ansi150	67	102	21	F05	50	M6	16/10	150	92	1,6	18	120,6	4	19	14,4	178 (4)
L/V471BD609	L/V571AD609	DN50	51	ansi300	67	102	21	F05	50	M6	16/10	165	92	1,6	21	127,0	8	19	17,2	216 (4)
L/V470B0610	L/V570A0610	DN65	64	PN16	83	130,5	28	F07	70	M8	22/14	185	122	3	18	145	4	18	20,2	170 (1)
L/V471B0610	L/V571A0610	DN65	64	PN25-40	83	130,5	28	F07	70	M8	22/14	185	122	3	22	145	8	18	28,2	270 (2)
L/V470BD610	L/V570AD610	DN65	64	ansi150	83	130,5	28	F07	70	M8	22/14	180	104,8	1,6	22,6	139,7	4	19	23,1	191 (4)
L/V471BD610	L/V571AD610	DN65	64	ansi300	83	130,5	28	F07	70	M8	22/14	190	104,8	1,6	26,1	149,2	8	22	27,3	241 (4)
L/V470B0611	L/V570A0611	DN80	76	PN16-40	90	137,5	28	F07	70	M8	22/14	200	138	3	24	160	8	18	25,4	180 (1)
L/V470BD611	L/V570AD611	DN80	76	ansi150	90	137,5	28	F07	70	M8	22/14	190	127	1,6	24	152,4	4	19	27	203 (4)
L/V471BD611	L/V571AD611	DN80	76	ansi300	96	137,5	28	F07	70	M8	22/14	210	127	1,6	29	168,3	8	22	28,6	282 (4)
L/V470B0612	L/V570A0612	DN100	102	PN16	111	172	35	F10	102	M10	30/18	220	158	3	20	180	8	18	38	190 (1)
L/V471B0612	L/V571A0612	DN100	102	PN25-40	111	172	35	F10	102	M10	30/18	235	162	3	22	190	8	22	57,8	300 (2)
L/V470BD612	L/V570AD612	DN100	102	ansi150	111	172	35	F10	102	M10	30/18	230	157,2	1,6	24,6	190,5	8	18	46	229 (4)
L/V471BD612	L/V571AD612	DN100	102	ansi300	111	172	35	F10	102	M10	30/18	255	157,2	1,6	32,6	200,0	8	22	67,7	305 (4)
L/V470B0613	L/V570A0613	DN125	118	PN16	117	182	35	F10	102	M10	30/18	250	188	3	22	210	8	18	68	325 (2)
L/V470BD613	L/V570AD613	DN125	118	ansi150	117	182	35	F10	102	M10	30/18	255	185,7	1,6	24	215,9	8	22	62	254 (3)
L/V471BD613	L/V571AD613	DN125	118	ansi300	125	182	35	F10	102	M10	30/18	280	185,7	1,6	36,6	235	8	22	89	381 (3)
L/V470B0614	L/V570A0614	DN150	152	PN16	154	227,5	40,5	F14	140	M16	45/30	285	212	3	22	240	8	22	121	350 (2)
L/V470BD614	L/V570AD614	DN150	152	ansi150	154	227,5	40,5	F14	140	M16	45/30	280	216	1,6	25,6	241,3	8	22	126	394 (4)
L/V470B0615	L/V570A0615	DN200	203	PN16	188	274	44,8	F14	140	M16	52/35	340	268	3	24	295	12	22	198	400 (2)
L/V470BD615	L/V570AD615	DN200	203	ansi150	188	274	44,8	F14	140	M16	52/35	345	269,9	1,6	29	298,4	8	22	210	457 (4)

(1) EN558 TAB. 2 COL. 14 / DIN 3202-1 F4

(2) EN558 TAB. 2 COL. 15 / DIN 3202-1 F5

(3) ANSI B16.10

(4) B16.10 / API6D

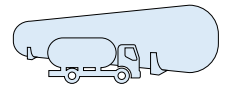

**SPRING RETURN
PNEUMATIC
ACTUATOR PN 16-40**

**PN 16-40 Split Body Series
Spring Return Pneumatic Actuator**

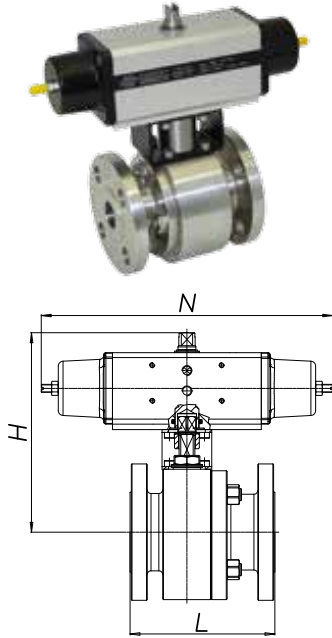

PN 16-40 Wafer Serie Spring Return Pneumatic Actuator									
Body Stainless Steel	Body/ Carbon Steel	Actuator	Connecting Kit	SIZE	PN	N	H	Kg	L
S470BH064	S570AH064	SR015401S	KCF033761	DN 15	16	221	152,4	4,5	115
S471BH064	S571AH064	SR030402S	KCF043767		25-40	240	162,4	4,8	
S470BH065	S570AH065	SR030402S	KCF043767	DN 20	16-40	240	165,4	6,0	120
S470BH066	S570AH066	SR030402S	KCF043807	DN 25	16-40	240	172,4	7,6	125
S470BH067	S570AH067	SR045401S	KCF053768	DN 32	16-40	294	184,5	10,8	130
S470BH068	S570AH068	SR060401S	KCF053764	DN 40	16-40	320	224,4	13,2	140
S470BH069	S570AH069	SR090401S	KCF073769	DN 50	16	375	243	18,8	150
S471BH069	S571AH069	SR120401S	KCF073769		25-40	372	253,4	20,7	
S470BH070	S570AH070	SR120401S	KCF073765	DN 65	16	372	279,4	26,7	170
S471BH070	S571AH070	SR180401S	KCF103770		25-40	436	291	37,2	
S470BH071	S570AH071	SR180401S	KCF103770	DN 80	16	436	298	35,4	180
S471BH071	S571AH071	SR240401S			25-40	456	310	36,2	
S470BH072	S570AH072	SR360401S	KCF104150	DN 100	16	566	369	56,0	190
S471BH072	S571AH072	SR480401S	KCF123771		25-40	602	381,2	76,8	
S470BH073	S570AH073	SR480401S	KCF123778	DN 125	16	602	384,2	87,1	325
S470BH074	S570AH074	SR720401S	KCF163901	DN 150	16	834	613	178	350
S470BH075	S570AH075	SR1440E16D8A	KCF163903	DN 200	16	975	622,5	282	400

**SPRING RETURN
PNEUMATIC
ACTUATOR ANSI 150-300**

**ANSI 150-300 Split Body Series
Spring Return Pneumatic Actuator**

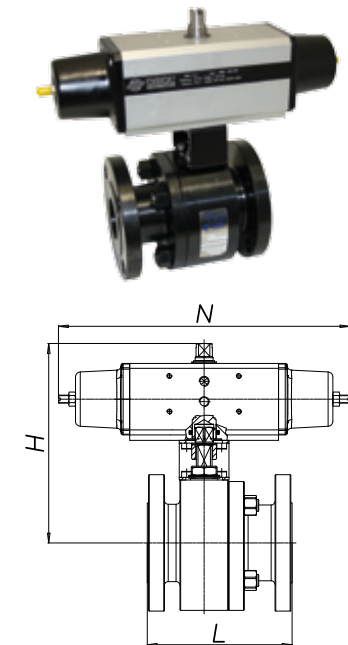

PN 16-40 Wafer Serie Spring Return Pneumatic Actuator									
Body Stainless Steel	Body/ Carbon Steel	Actuator	Connecting Kit	SIZE	ANSI	N	H	Kg	L
S470BHD64	S570AHD64	SR015401S	KCF033761	DN 15	Ansi 150	221	152,4	4,0	108
S471BHD64	S571AHD64	SR030402S	KCF043767		Ansi 300	240	162,4	4,7	140
S470BHD65	S570AHD65	SR030402S	KCF043767	DN 20	Ansi 150	240	165,4	5,3	117
S471BHD65	S571AHD65				Ansi 300	240	164,4	6,3	152
S470BHD66	S570AHD66	SR030402S	KCF043807	DN 25	Ansi 150	240	172,4	6,9	127
S471BHD66	S571AHD66				Ansi 300	240	172,4	8,3	165
S470BHD67	S570AHD67	SR045401S	KCF053768	DN 32	Ansi 150	294	184,5	7,2	140
S471BHD67	S571AHD67				Ansi 300	294	184,5	11,8	178
S470BHD68	S570AHD68	SR060401S	KCF053764	DN 40	Ansi 150	320	224,4	15,2	165
S471BHD68	S571AHD68				Ansi 300	320	224,4	17,8	190
S470BHD69	S570AHD69	SR090401S	KCF073769	DN 50	Ansi 150	357	243	18,8	178
S471BHD69	S571AHD69	SR120401S			Ansi 300	372	254,4	24,1	216
S470BHD70	S570AHD70	SR120401S	KCF073765	DN 65	Ansi 150	372	279,4	29,6	191
S471BHD70	S571AHD70	SR180401S	KCF103770		Ansi 300	436	291	36,5	241
S470BHD71	S570AHD71	SR180401S	KCF103770	DN 80	Ansi 150	436	298	37,0	203
S471BHD71	S571AHD71	SR240401S	KCF103892		Ansi 300	456	310	49,4	282
S470BHD72	S570AHD72	SR360401S	KCF104150	DN 100	Ansi 150	566	369	62,8	229
S471BHD72	S571AHD72	SR480401S	KCF123771		Ansi 300	602	381,2	86,8	305
S470BHD73	S570AHD73	SR480401S	KCF123778	DN 125	Ansi 150	602	387,2	81,8	254
S471BHD73	S571AHD73	SR720401S	KCF143899		Ansi 300	712	421	117	381
S470BHD74	S570AHD74	SR720401S	KCF163901	DN 150	Ansi 150	834	613	190	394
S470BHD75	S570AHD75	SR1440E16D8A	KCF163903	DN 200	Ansi 150	975	622,5	283	457



CAVAGNA group

Advanced solutions for gas control



Quality Management System to ISO 9001 standard

Quality: our prerogative!

Registration to ISO 9001 standards is for us not only a certificate. Our policy is to achieve the outmost customer satisfaction, through the effectiveness of our Quality Management Systems and through continuous improvement to suit the dynamic Customers' expectations.

Personnel involvement, training and motivation are few of the elements that we rely on to achieve quality from each person and from each process.

Quality: our "must"

LPG **5** YEARS LIMITED WARRANTY

1 - Compliance of the products

Subject to the provisions of this article, the seller guarantees the compliance of the products supplied; by the term "compliance of the products" is meant that they correspond in quantity, quality, and type with what was agreed in the contract and that they are without defects that could render them unfit for the use to which they are intended to be put.

2 - Extent of the guarantee

The guarantee against defects is limited only to product defects due to defects in planning, materials or construction that can be attributed to the seller, and does not apply in the case where the buyer is unable to prove a correct preservation of the products, and neither that he has modified them without the agreement of the seller.

Furthermore, the seller is not liable for defects in product compliance due to the normal wear of those parts, which by their nature, are subject to rapid and continuous wear and tear (for example: lining, etc.).

In general, in no case is the seller liable for defects in compliance, whose cause lies in a fact subsequent to the transfer of risk to the buyer.

The present guarantee is valid only when the products are installed, used and maintained in conformity with the instructions furnished by the seller (inserted in the Warning Paper) and with the requests and dispositions of the voluntary or mandatory laws and regulations existing in the country where the products are used or, where there's no laws, in conformity with the good technical work rules of the sector.

3 - Claims

The buyer is required to control the compliance of the products and the absence of flaws. The buyer should report any flaws or defects in product compliance, in the following ways:

- Claims for shortage or damages apparent from exterior examination of package contents must be expedited as soon as the products arrived at their place of destination or risk forfeiture;
- claims relevant to quantity, colour, quality flaws or defects or non-compliance that the buyer would be able to point out as soon as he takes possession of the goods, must be made shortly after the time when the products arrived at their place of destination and, in any event, on lapse of the guarantee not later than 15 days after that time;
- hidden flaws, defects or non-compliance (that is, those not identifiable according to the inspection imposed by law and by the preceding subparagraph on the buyer) must be reported shortly after the discovery and in any event, on lapse of the guarantee, not later than 5 years from the delivery date.

Claims must be made by registered letter, addressed to the head office of the seller and must describe in detail the flaws or disputed non-compliance.

In order to preserve this warranty, the buyer will not execute any intervention on the product (disassembling, repair, modification, etc.) without the seller prior written agreement.

The buyer forfeits his guarantee rights if he does not consent to every reasonable control requested by the seller, or if after the seller has requested the return of the defective products at his own expenses, the buyer omits to return them within 5 working days from the request.

In the event that the claim turns out to be unfounded, the buyer will be required to reimburse the seller for all the expenses sustained by him in verifying the claim (travel, expert valuations, transport expenses etc..).

4 - Remedies

Following a report by the buyer duly made in accordance with the previous point 3, the seller, within a reasonable period having regard to the context of the claim, may, at his discretion:

- supply ex factory to the buyer products of the same kind and quantity as those that have been proved to be defective or not in compliance with what was

agreed; in such a case the seller can require the return of the defective products, which become his property.

b) declare in writing the cancellation of the contract, offering the restitution of the sum paid against the restitution of the supplied products.

No other cost (such as disassembling and/or reassembling of the products, transportation from/to the premises of buyer's customers, etc.) shall be charged to the seller.

5 - Limit of seller's liability

The guarantee contained in the previous points supersedes all legal warranty for defects and compliance, and excludes any other possible liability of the seller, however originating, from the products supplied. In particular, the buyer can not put forward another claim for compensation in respect of any further damages, reduction of the price or cancellation of the contract. Once the period of the guarantee has expired no valid claim can be made against the seller.

In no event shall seller be liable to buyer for any direct, incidental, indirect, consequential or exemplary damages, including without limitation any claim for damages based on lost revenues or profits, however caused.

No exceptions to the provisions of the present point and to the previous ones will be considered valid unless expressly and specifically defined and accepted by the parties in writing.

6 - Technical regulations

Whereas for that which concerns the product characteristics the seller complies with the legislation and the technical regulations prevailing in Italy and the European Directives, and that will be furnished on request, the buyer assumes the whole risk of any difference between the European Directives plus the Italian regulations and those of the country of destination of the products, and indemnifies the seller in respect of it, unless if they have been previously communicated to him.

The seller guarantees the performance of products of his manufacture only and exclusively in relation to uses, destinations, applications, tolerances, capacities, etc.. that have been expressly indicated by him, with the sole exception of uses, destinations and applications that, to the common knowledge acquired by normal users, are clearly and unequivocally attributable to the products in question.

The buyer is not authorised to dispose of the products supplied to him by the seller in a way which does not conform to the indications described in the previous sub-paragraph and in the instruction given by seller.

Where the buyer intends the said products to be resold, it shall be his responsibility:

- informing his purchasers of the indications in question;
- any further periods of guarantee he decides to grant to his purchasers exceeding the ones granted to him by Seller according to paragraph 3

7 - Personal injuries and property damages

Seller shall indemnify buyer from and against any and all claims, demands, losses, liabilities alleged by third parties relating to personal injuries and property damages suffered as a result of a defective product. In such event, seller will exclusively be responsible within the limits, terms and conditions of the product liability insurance policy held by it (a copy of the current policy is available upon request).

In case of potential damages to third parties that may arise from a defective product, the parties shall work together in good faith to determine the nature and extent of the appropriate measures to be taken, including recall operations. It is understood that the costs and expenses associated with the recall or other measures shall be paid by seller within the limits, the terms and the conditions set forth in its liability insurance policy, with the exclusion of the costs connected to the finding of the Products in the market, that will be supported by the Buyer.

Our Global Product Brands



CAVAGNA group

Advanced solutions for gas control



The Cavagna Group logo is a registered trademark of Cavagna Group SPA.

All other marks are the property of their respective owners.

RECA, KOSAN +, KOSANGAS , CEMCO KOSANGAS, O.A.R.A., OMECA, N.P. and BIGAS, are marks of the Cavagna Group of Companies LPG Division.

The contents and pictures of this publication are presented for informational purposes only, and while every effort has been made to ensure their accuracy, they are not to be construed as warranties or guarantees, regarding the products or services described herein or their use or applicability. We reserve the right to modify or improve the designs or specifications of such products at any time without notice.

Manufacturing Facilities



cavagna group
Advanced solutions for gas control

pergola
ITALY

omeca
ITALY

bigas
ITALY

MESURA
FRANCE

MESURA
TUNISIA

Kosangas
PORTUGAL

Zhongshan cavagna
CHINA

cavagna group asia
THAILAND

cemco kosangas
CHILE

concrip
VENEZUELA

recq|a.a.a.
ITALY

cavimatic
ITALY

cori
ITALY

Kosan INTERNATIONAL
ITALY

n.p.
ITALY

MESURA Nimal
Gas Control
INDIA

cavagna group sudamericana ltda
COLOMBIA





cavagna group

Advanced solutions for gas control

CAVAGNA GROUP SPA

Via Statale 11/13 - Frazione Ponte San Marco

25011 Calcinato - Brescia (Italy)

Tel. 0039 030 9663111 - Fax 0039 030 9969014

info@cavagnagroup.com

www.cavagnagroup.com