



TRANS-VALVE
— SPECIALTY VALVES FOR INDUSTRY —

Fig. 115 B

150# Flanged Wafer Style Stainless Steel Transmitter Isolation Ball Valve

Installation, Operation and Maintenance Instructions

INTRODUCTION

This Instruction manual includes installation, operation, maintenance and engineering information for Trans-Valve Fig. 115 B Stainless Steel Transmitter Isolation Ball Valves.

STORAGE

Valves are shipped in individual plastic bags with added flange area protection. Valves should be stored in a clean, dry, sheltered area to prevent any possible contamination from weather or foreign materials. The valve seats and seals (soft goods) have an unlimited shelf life when properly stored.

PRE-INSTALLATION

It is the responsibility of the end user to ensure the valve materials, including soft goods, are compatible with the process media. All applicable valve/piping standards and best practices regarding valve installation procedures must be understood and followed. The following should be read and understood prior to the installation of the valve.

WARNING: To avoid personal injury to yourself, fellow workers, or possible damage to property from accidental release of process media, the following steps should always be taken prior to valve installation:

- A. Shut off all operating lines to the valve installation location and isolate the area completely from the process.
- B. Release the process pressure.
- C. Vent and drain the process fluid or media from the valve location.
- D. Cycle the valve to release any trapped pressure.

INSTALLATION

The Fig. 115 B has a tank side flange drilled and tapped to accommodate a 25° to 27° offset (Knife Gate) flange pattern. When used as a direct replacement for a Knife Gate Valve, the valve must be mounted with the handle located in the bottom quadrant to utilize the offset bolt pattern at the top of the tank flange.

Trans-Valve offers complete stainless-steel fastener kits for applicable flange mounting patterns. Contact your distributor for pricing.

Instructions for mounting Fig. 115 B to Knife Gate Valve pattern tank flange

1. Install two 5/8-11 x 2-1/2" threaded studs into the tapped offset holes at the top of the tank flange and two 5/8-11 x 4-3/4" threaded studs into the tapped holes in the bottom of the tank flange.
2. Install a gasket between the tank flange and tank side of the valve body.
3. Push the tank side of the valve (handle in the bottom quadrant) up against the tank flange, allowing the center protrusion of the valve to enter the bore of the tank flange. The four studs will pass through the mating holes of the valve body.
4. Install 5/8-11 hex nuts and lock washers on the four threaded studs and tighten in a staggered sequence to compress the gasket between the tank flange and the valve until a leak-tight seal is accomplished.
5. Install a gasket between the instrument side of the valve and the transmitter flange.
6. Push the transmitter flange up against the instrument side of the valve body, allowing the two bottom studs to pass through the holes at the bottom of the transmitter flange.
7. Install two 5/8-11 x 2-3/4" hex head cap screws and lock washers into the top of the transmitter flange holes and install two 5/8-11 hex nuts and lock washers onto the studs on the bottom of the transmitter flange and tighten all four in a staggered sequence until the gasket is compressed enough to form a leak-tight seal.
8. Connect purge ports as needed (see section on purge port use and connection below).

Purge Port Use and Connection

The Fig. 115 B valve is unique in design compared to our standard models 105 B and 105 BD. The valve has special SS-TFE seats made of 50% 316 powder combined with 50% TFE which combines the strength of metal with the lubricity of TFE. ***The abrasion resistance of metal with higher pressure and temperature ratings (-20°F to 550°F / Steam rating 250 SWP), along with a milled flat on the bottom of the ball, allows purging to the exterior without any back flow into the tank. This makes this model suitable for use in tougher applications, allowing the use of steam as the purge media. Steam purge to be momentary and intermittent using steam rated 250 SWP or less.***

The Fig. 115 B Transmitter Isolation Ball Valve has (3) ¼" FNPT purge ports plugged with 316 stainless steel MNPT plugs. The calibration port (marked with letter "C" on body) is used for relieving pressure, some discharge and then calibration of the instrument. Calibrate with the ball closed. One purge port is located opposite the calibration port (C) and the second purge port is located at the top of the valve body opposite the handle. With the ball closed, one port can be used for the purge inlet and the other for purge exhaust. The purge media will flush and clean the instrument side of the valve and then exhaust externally. *For safety, we suggest containing all purged materials to avoid slips, falls and other environmental hazards.*

OPERATION

The Fig. 115 B is designed for service in level transmitter isolation applications that meet the pressure/temperature limits of the valve materials (*see chart below*).

All valves are supplied with lever handles for quarter-turn manual operation. The sliding latch device locks the handle in the closed position and prevents accidental lever operation. Also, the valve can be padlocked in the closed position, if needed.

To manually operate the valve, slide the latch device and turn the handle 90° clockwise to open. Turning the handle 90° counter - clockwise will close the valve. Valve position can be determined by the position of the handle in relation to the instrument. The handle will be parallel to the instrument when open and perpendicular to the instrument when closed.

Avoid operating and/or purging the valve with the ball in a partially open/closed position. Critical pressure drops and high flow rates can damage the seats, making the valve inoperable.

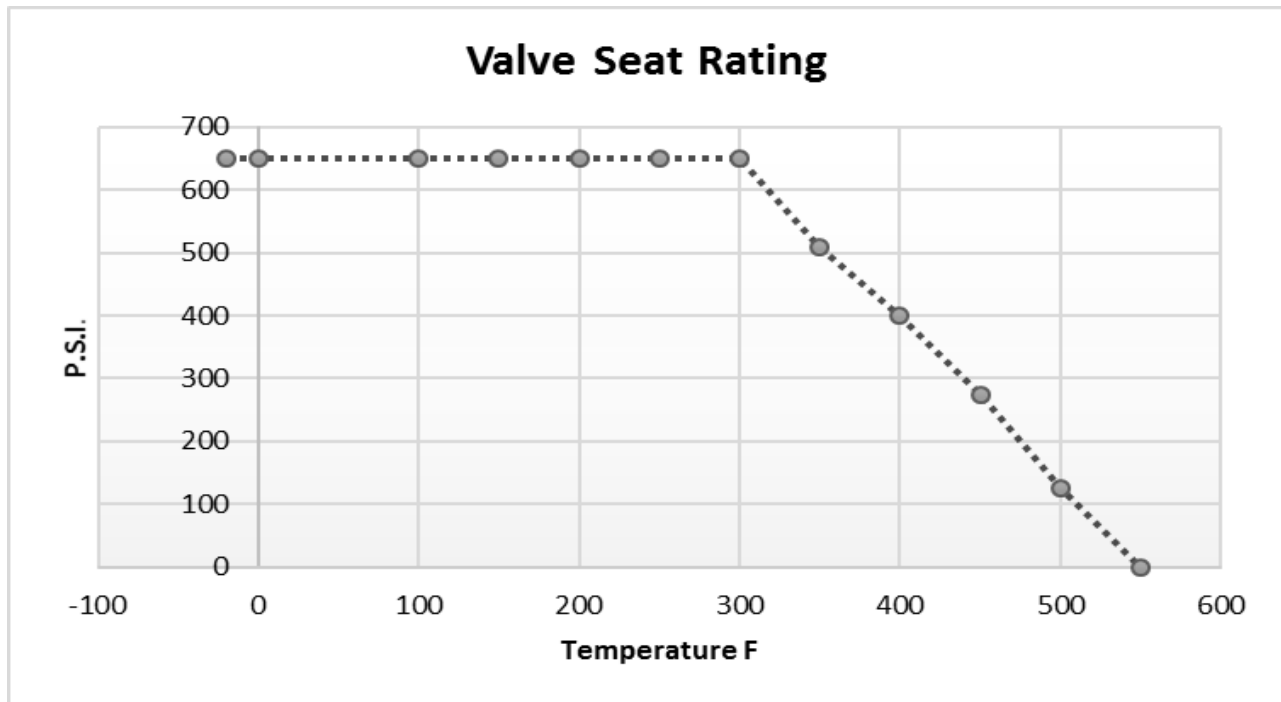

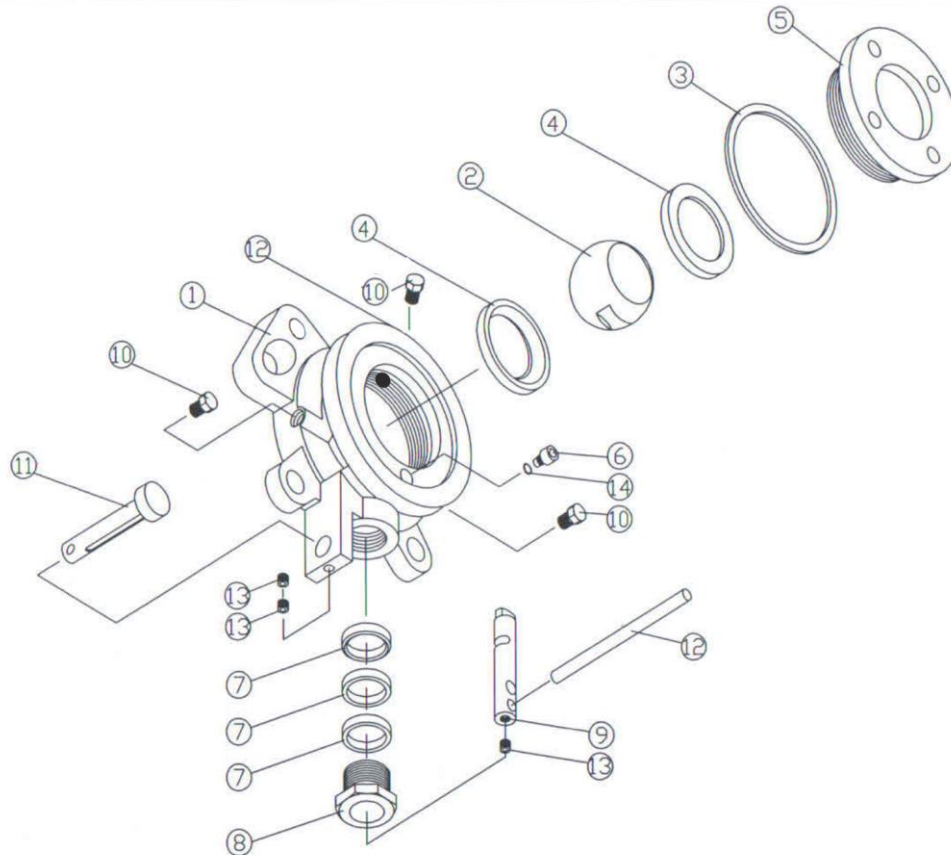

ITEM	DESCRIPTION	MATERIAL	QTY
1	BODY	ASTM A351 CF8M	1
2	BALL	ASTM A351 CF8M	1
3	RETAINER GASKET	TEFLON	1
4	SEAT	50 SS / 50TFE	2
5	RETAINER	ASTM A351 CF8M	1
6	STOP PIN	SUS 304	1
7	PACKING	TEFLON	1
8	GLAND NUT	SUS 304	1
9	STEM	SUS 304	1
10	1/4 NPT PLUG	SUS 316	3
11	LOCKOUT PIN	SUS 304	1
12	HANDLE	SUS 304	1
13	SET BOLT	SUS 304	3
14	SEAL	PTFE	1

MAINTENANCE

Valve parts are subject to normal wear and should be periodically inspected and replaced, as necessary. The type and frequency of repair depends on the service conditions. Due to the nature of the application for the Fig. 115 B, soft goods replacement should not be necessary. The only area that may occasionally require adjustment to compensate for stem movement and packing fatigue caused by pressure changes is the live loaded stem packing.

If leakage is detected at the stem, the packing can be adjusted by tightening the packing nut in $\frac{1}{4}$ turn intervals until the leak stops. If the nut cannot be tightened any further and the packing continues to leak, the valve should be replaced.