



**TRANS-VALVE**  
—SPECIALTY VALVES FOR INDUSTRY—

**Figure 105 BD**  
**Transmitter Isolation**  
**Ball Valve**

**Features:**

- Quarter turn
- 316 Stainless Steel
- Bubble tight shutoff as defined by exceeding both ANSI/FCI 70-2-1976 Class VI and API 598 standards
- 1 calibration and 1 purge port
- Full 3" diameter diaphragm sensing area
- Integral closed position locking device
- Mounts to standard ANSI 150# 4 bolt tank flange pattern

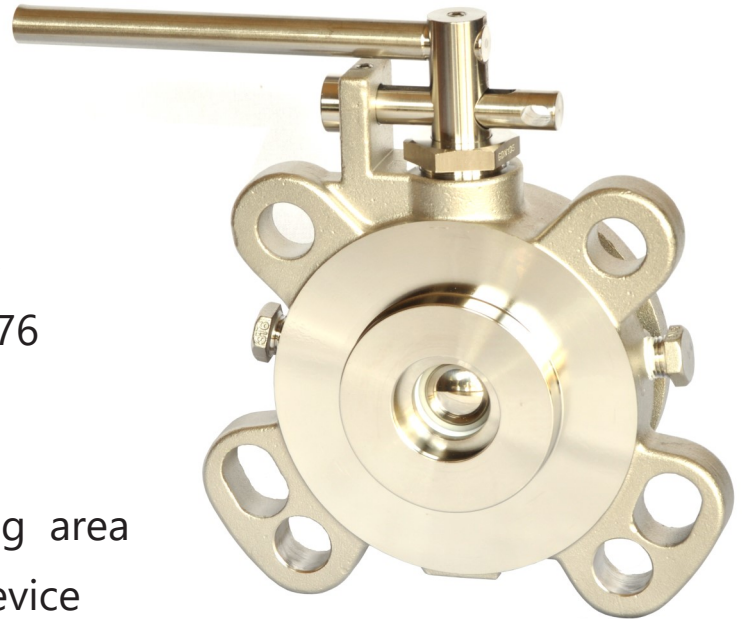

**Description:**

The Figure 105 BD is a quarter turn ball valve of transmitter isolation design that has a thin profile and mounts to an ANSI 150 # 4 bolt tank flange pattern. It is an all stainless steel valve with RTFE seats and PTFE seals. The quarter turn handle allows for quick operation and the multiple purge ports provide easy body as well as instrument side cleaning and calibration in place. Bubble tight shutoff as valve exceeds both the Class VI ANSI/FCI 70-2-1976 and API 598 standards.

[www.trans-valve.com](http://www.trans-valve.com)



**TRANS-VALVE**  
—SPECIALTY VALVES FOR INDUSTRY—



**TRANS-VALVE**  
—SPECIALTY VALVES FOR INDUSTRY—

## Figure 105 BD Transmitter Isolation Ball Valve

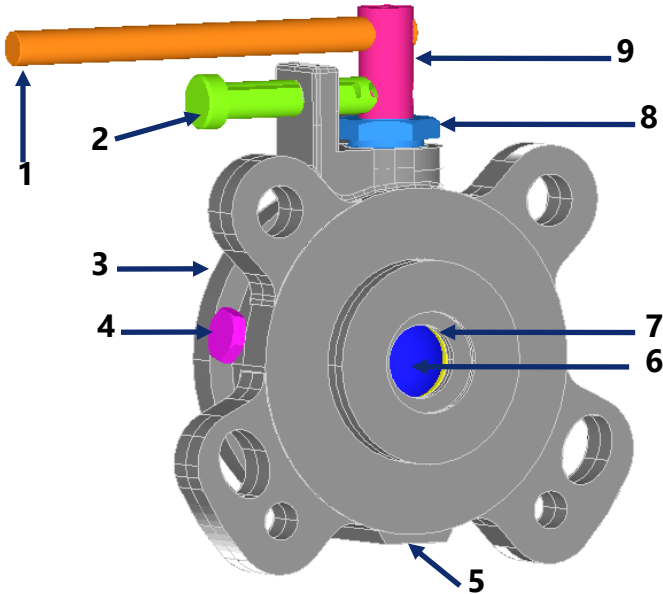

<u>Number</u>	<u>Part</u>	<u>Material</u>	<u>Quantity</u>
1	Handle	304 SS	1
2	Lockout Pin	304 SS	1
3	Body	ASTM A351 CF8M	1
4	1/4" NPT Plug	304 SS	2
5	Name Plate	ASTM A351 CF8M	1
6	Ball	ASTM A351 CF8M	1
7	Seat	RTFE	2
8	Gland Nut	304 SS	1
9	Stem	ASTM A351 CF8M	1

### Specification:

Valve shall be a ball valve of transmitter isolation design with a 316 stainless steel body, a 3" sensing area and a 1" port. It is to have a tank side flange drilled to accommodate a standard ANSI 150# 4 bolt flange pattern. Valve shall have a stainless steel locking closed handle. Valve to have (1) one purge port in cavity behind the ball and (1) calibration / purge port, 1/4" NPT using a MNPT plug made of 316 stainless steel. One purge port to purge body through (3) holes in the body of the valve. Calibration / purge port is to be clearly marked on valve body. Seats to be made of RTFE; seals to be made of PTFE; retainer gasket and packing in Teflon. Valve to use standard 5/8-11 hex head cap screws for easy installation. Valve tested to exceed both the API 598 and ANSI / FCI 70-2-1976 Class VI standards.

