



**TRANS-VALVE**  
—SPECIALTY VALVES FOR INDUSTRY—

**Figure 15 B**  
Sampling Valve

## **Features:**

- 1 ½" MNPT Inlet X 1 ½" Outlet
- All wetted parts in 316 Stainless Steel (CF8M)
- Resilient Nitrile seat Standard; Optional seats available in: Viton, PEEK and UHMWPE.
- Integral pail hook
- Lever handle operated for ease of use
- Industry best warranty (2 year)
- Spring returns valve to closed position for safety
- Rated 150 PSI



## **Description:**

The Figure 15 B is a spring-closed, plunger type sampling valve designed for taking occasional samples from pipes or tanks. It is cast in stainless steel for corrosion resistance. The resilient Nitrile seat provides a tight shutoff. Depending on application, other seat materials are available in: Viton, PEEK and UHMWPE. Note the convenient pail hook included in the design.

[www.trans-valve.com](http://www.trans-valve.com)



**TRANS-VALVE**  
—SPECIALTY VALVES FOR INDUSTRY—



**TRANS-VALVE**  
—SPECIALTY VALVES FOR INDUSTRY—

**Figure 15 B**  
Sampling Valve

Number	Part	Material	Quantity
1	Seat	Buna-N	1
2	Disc	316 SS	1
3	Retaining Ring	304 SS	1
4	Body	CF8M	1
5	Rod	316 SS	1
6	O-Ring Seal	Viton	1
7	Gland	304 SS	1
8	Spring	304 SS	1
9	Gland Nut	304 SS	1
10	Handle Nut	304 SS	2
11	Handle Bolt	304 SS	2
12	Lever	304 SS	1
13	Handle Grip	Vinyl	1

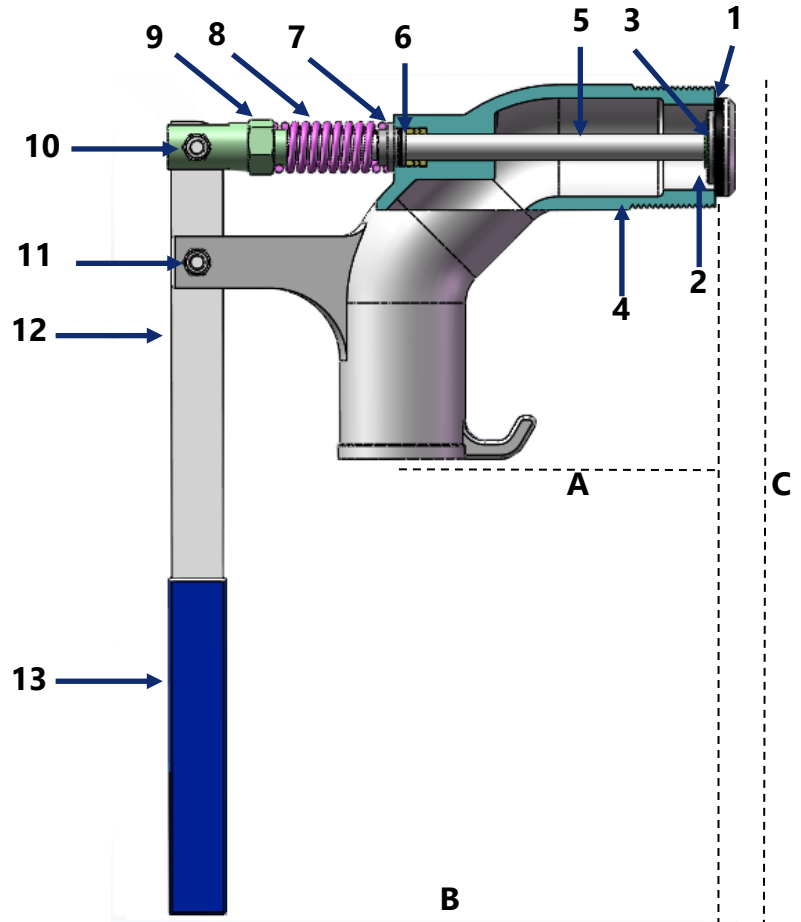

**Physical Data**

**A = 4.75" B = 8.30" C = 11.25"**

**Weight = 5 lbs.**

**Technical Specification:**

Valve shall be a lever handle operated, plunger type, spring closed sampling valve. Valve body to be cast in 316 stainless steel and to include integral pail hook. Inlet to be 1 1/2" MNPT and outlet 1 1/2". All wetted parts to be of 316 stainless steel. Standard offering resilient seat to be of Nitrile BUNA-N material with optional seats available in: Viton, PEEK and UHMWPE. Valve shall be rated to 150 PSI.

[www.trans-valve.com](http://www.trans-valve.com)

Rev.3 11.20.19



**TRANS-VALVE**  
—SPECIALTY VALVES FOR INDUSTRY—