



TRANS-VALVE
—SPECIALTY VALVES FOR INDUSTRY—

Figure 305 AT Transmitter Isolation Ball Valve

Features:

- ASTM B367 C5 titanium body, Gr. 5 titanium ball, stem and MNPT plug. For use with concentrated chlorinated media.
- True, 3" Full port
- Quarter turn open / close
- Bubble tight shutoff as defined by exceeding both API 598 and ANSI/FCI 70-2-1976 Class VI standards
- 45° Handle for fitting in tank recess insulation
- Body Purge, Diaphragm Wash and Instrument Calibration performed through one port
- Instrument calibration in place
- Integral padlock locking device either open or closed
- Uses standard hex head cap screws for easy installation

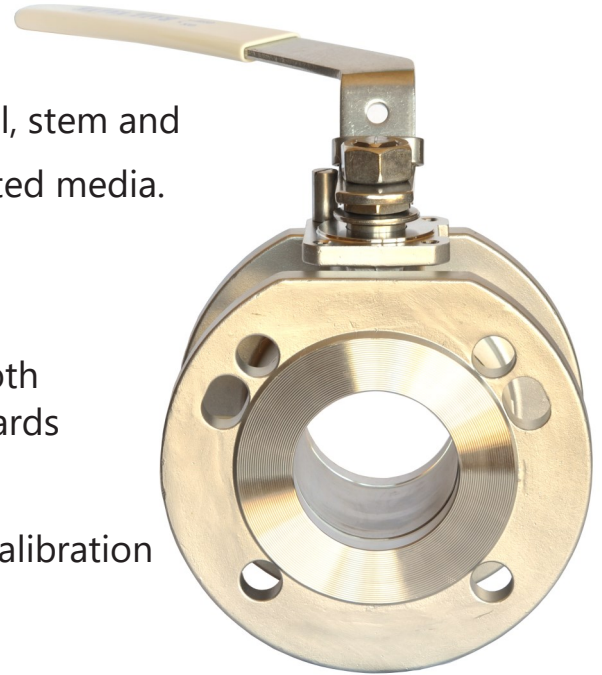

Description:

The Figure 305 AT is built on the successful, patented design of the Figure 305 B, with specific material modifications to work with concentrated chlorinated media. The body of the Figure 305 AT is Grade 5 titanium and the ball, stem and 1/4" MNPT plug are also made of Grade 5 titanium. This valve is corrosion resistant, bubble tight and easily installed as a replacement for knife gate valves or in 3" ANSI 150 # 4 bolt flange patterns. Bubble tight shutoff as valve exceeds both the API 598 and ANSI/FCI 70-2-1976 Class VI standards.

www.trans-valve.com



TRANS-VALVE
—SPECIALTY VALVES FOR INDUSTRY—



TRANS-VALVE
—SPECIALTY VALVES FOR INDUSTRY—

Figure 305 AT Transmitter Isolation Ball Valve

Number	Part	Material	Quantity
1	Handle	304 SS	1
2	Latch Lock	304 SS	1
3	Stop Pin	304 SS	1
4	Body	Titanium GR5	1
5	1/4" NPT Plug	Titanium GR5	1
6	Ball	Titanium GR5	1
*	Stem	Titanium GR5	1
7	Seats	RPTFE	2
8	Mount Pad	Titanium GR5	1
9	Spring Washers	304 SS	2
10	Nut	304 SS	1
11	Handle Nut	304 SS	1

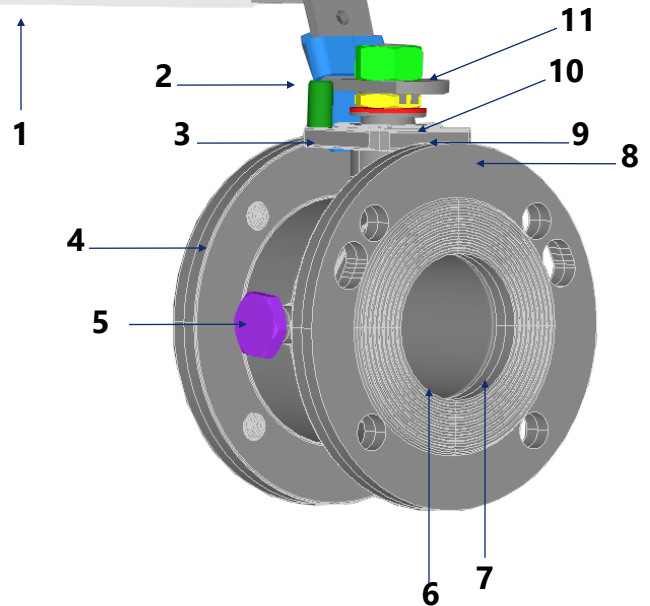

Technical Specification:

Valve shall be a ball valve transmitter isolation design with a Titanium GR5 body and a true, full 3" port. It is to have a tank side flange to accommodate both: standard 3" ANSI 150 # 4 bolt flange pattern and a 26° to 28° offset (knife gate) flange pattern. The instrument end flange is to be drilled and tapped to accommodate a standard 3" ANSI 150 # 4 bolt flange pattern. Valve shall have a 45° offset stainless steel lockable handle. Valve includes an integral actuator mounting pad. Valve to have single purge / calibration port, 1/4" NPT using a MNPT plug made of the same material as the ball and stem: Grade 5 titanium. Single port flushes body cavity and diaphragm face when valve is open and allows pressure release, removal or in place calibration of transmitter when valve is closed. Seats to be made of RPTFE; retainer plate gasket and thrust washer in PTFE. Valve to use standard 5/8-11 hex head cap screws for easy installation. Valve tested to exceed both the API 598 and ANSI / FCI 70-2-1976 Class VI standards.

www.trans-valve.com

Rev. 1 10.26.2023



TRANS-VALVE
—SPECIALTY VALVES FOR INDUSTRY—