

# WILLIAM FRANKI

WITHIN IN AN AGILE FRAMEWORK: TEAM LEADERSHIP | TECHNICAL WRITING | TRAINING DESIGN  
DATA ANALYSIS | INFORMATION ARCHITECTURE | PROCESS ENGINEERING | MEDIA DEVELOPMENT

## SAMPLE DELIVERABLES

### SECTION 1

#### MAINTENANCE DOCUMENTATION

---

This section illustrated the improvement of Piping and Instrumentation Diagrams (P&ID) requiring significant data research and organization. It begins with a legacy diagram modified by me to ultimately include component identifiers, as well as material contents and directional flow information. The identifiers tied back to Liquefied Petroleum Gas (LPG) maintenance procedures I developed allowing an operator/technician to see components in context while following the procedure. I also created a master "roll-up" data sheet containing all identified components for each of three LPG plants with uniquely developed procedures for. This was a massive data discovery and analysis activity that involved auditing three LPG plant record sets (hardcopy and electronic) and 12 SMEs, as well as on-site visits for validation.

Applications: Excel, Photoshop, Word, Acrobat, Teams.

### SECTION 2

#### DIRECTIVE DOCUMENTATION

---

Contains Field Service Bulletins allowing installation personnel to make required updates to their iPad or Android tablet.

Applications: FrameMaker, Photoshop, Acrobat, Google Docs, Teams.

### SECTION 3

#### INSTALLATION GUIDES

---

Comprises Three Field Installer Procedures Manuals. These were distributed via the IBM MaaS360 Mobile Device Management (MDM) system I implemented supporting over 250 tablets in the field.

Applications: FrameMaker, MS Word, Photoshop, Acrobat, Google Docs.

### SECTION 4

#### PROPOSAL

---

A proposal sample: Block Schematic Diagram (BSD) Training For Xerox Service Personnel and Dealers  
Develop training for Xerox Service Personnel and Dealers

Applications: MS Word, Visio, Acrobat.

### SECTION 5

#### ONLINE SAMPLES

---

A selection of various online samples.

Applications: FrameMaker, MS Word, Photoshop, Acrobat, Corel VideoStudio Pro, Audacity, WavePad, Google Docs.

**NOTICE:**  
 THIS DRAWING IS SUPPLIED BY STANDBY SYSTEMS, INC. (SSI) ON A CONFIDENTIAL BASIS TO THE PARTY OR PARTIES NAMED HEREIN SOLELY TO CLARIFY WORK PROPOSED OR CONTRACTED BY SSI. RELEASE TO ANOTHER PARTY OR ANY OTHER USE OF INFORMATION CONTAINED OR REFERENCED HEREIN IS NOT AUTHORIZED BY SSI. THIS DRAWING CONTAINS PROPRIETARY INFORMATION WHICH IS PROTECTED BY COPYRIGHT. ALL RIGHTS ARE RESERVED. REPRODUCTION BY ANY MEANS IS PROHIBITED.  
 © STANDBY SYSTEMS, INC. 2012

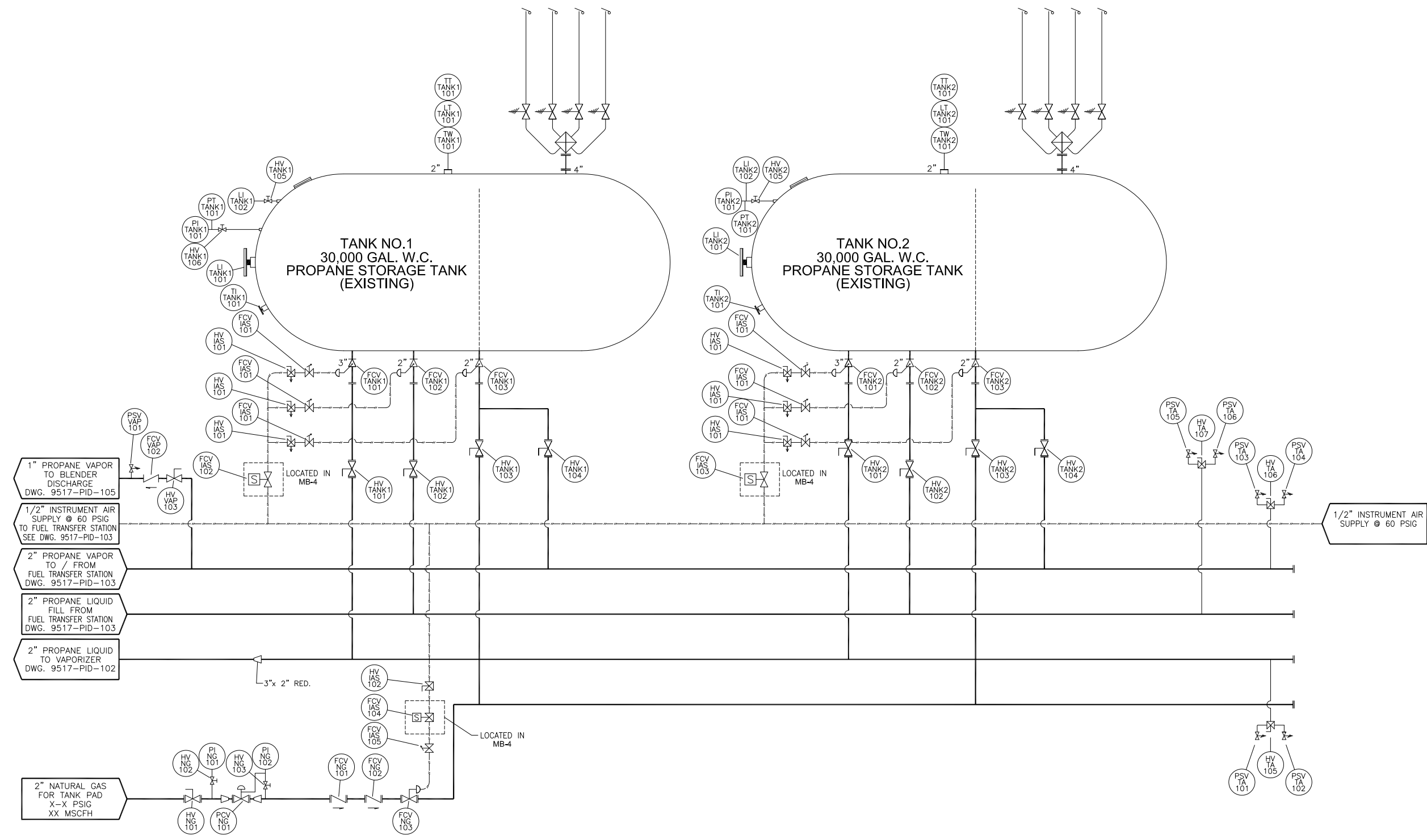

7	AS BUILT	1-3-13
6	DELETED VALVES, REVISED TAG NO.'S	9-19-12
5	ADDED HYDROSTATIC RELIEF VALVE	8-3-12
4	ADDED TANKS VAPOR TO BLENDER	7-19-12
3	ADDED TANK1 OPENING	6-29-12
2	REVISED LIQUID LINE SIZE	6-27-12
1	ADDED LIQUID LINE	5-9-12
0	PRELIMINARY	4-26-12
No.	Revision/Issue	Date



1313 Plymouth Avenue North  
 Minneapolis, Minnesota 55411-4065  
 Phone: 612-724-4473  
 Fax: 612-724-9434

Title FLOW DIAGRAM, NG PAD & TANKS	
Drawn By TEL	Date 4-17-12
Approved By -	Date -

Project No. 9517	Drawing No. 9517-PID-101
Date Plotted 1-3-13	Sheet 1 of 1
Scale NONE	

**NOTICE:**  
 THIS DRAWING IS SUPPLIED BY STANDBY SYSTEMS, INC. (SSI) ON A CONFIDENTIAL BASIS TO THE PARTY OR PARTIES NAMED HEREIN SOLELY TO CLARIFY WORK PROPOSED OR CONTRACTED BY SSI. RELEASE TO ANOTHER PARTY OR ANY OTHER USE OF INFORMATION CONTAINED OR REFERENCED HEREIN IS NOT AUTHORIZED BY SSI. THIS DRAWING CONTAINS PROPRIETARY INFORMATION WHICH IS PROTECTED BY COPYRIGHT. ALL RIGHTS ARE RESERVED. REPRODUCTION BY ANY MEANS IS PROHIBITED.  
 © STANDBY SYSTEMS, INC. 2012



**Legend:**

- █ Propane Vapor
- █ Instrument Air
- - - Propane Liquid
- █ Natural Gas

No.	Revision/Issue	Date
7	AS BUILT	1-3-13
6	DELETED VALVES, REVISED TAG NO.'S	9-19-12
5	ADDED HYDROSTATIC RELIEF VALVE	8-3-12
4	ADDED TANKS VAPOR TO BLENDER	7-19-12
3	ADDED TANK1 OPENING	6-29-12
2	REVISED LIQUID LINE SIZE	6-27-12
1	ADDED LIQUID LINE	5-9-12
0	PRELIMINARY	4-26-12



Title FLOW DIAGRAM, NG PAD & TANKS	
Drawn By TEL	Date 4-17-12
Approved By -	Date -

Project No. 9517	Drawing No. 9517-PID-101
Date Plotted 1-3-13	Sheet 1 of 1
Scale NONE	

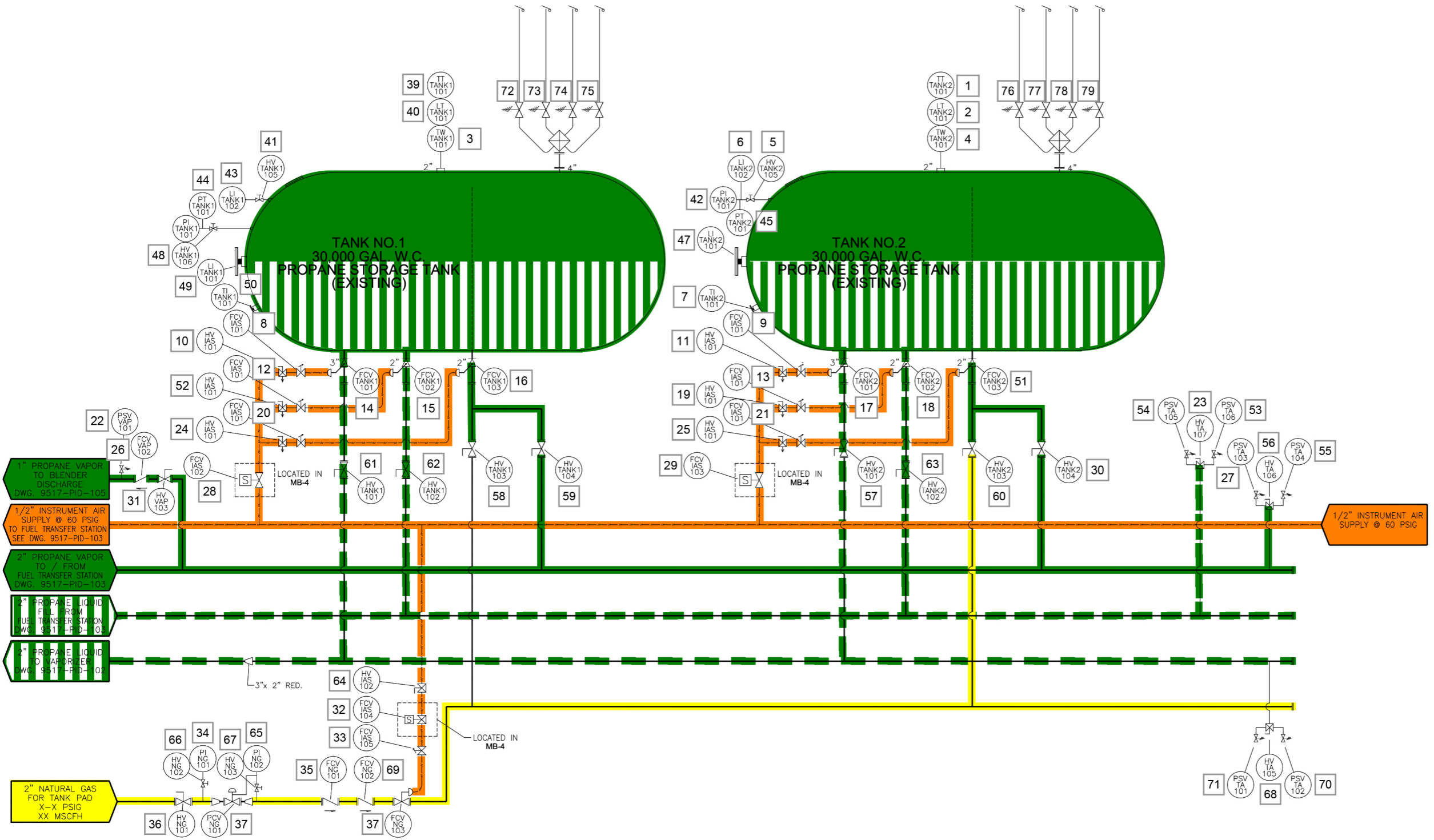

	<b>LPG MAINTENANCE PROCEDURE</b>	Procedure No: <b>GF-MP-006</b>
	<b>INSPECTING AND REPLACING PRESSURE SAFETY RELIEF VALVES</b>	Published Date: <b>01/18/2022</b>
		Superseded Date: <b>02/01/2022</b>
		Approved By: <b>T. Kennedy</b>

## I. OBJECTIVE

To ensure the safety of personnel and equipment by maintaining the safety relief valves as intended. This guideline applies to all Operating, Maintenance, and Contractor personnel.

## II. CODE REFERENCES

- A. All liquefied petroleum gas plants in Massachusetts shall be constructed, operated, and maintained according to the requirements of National Fire Protection Association 59 Utility LP-Gas Plant Code (2004) (NAPA 59), and,
- B. Applicable provisions of 220 CMR 101.00: Massachusetts Natural Gas Pipeline Safety Code, and,
- C. Applicable provisions of 49 CFR Parts 40, 192, and 199.

## III. FREQUENCY

Every 5 years.

## IV. SPECIAL TOOLS OR EQUIPMENT

PRV Socket.

## V. PPE

Hard hat, safety glasses, safety shoes, FR clothing and gloves. Hearing protection is required for rooms with running equipment.

## VI. LPG DOCUMENTATION

Replacement Log.

## VII. INSTRUMENT TAG DETAIL

<u>INSTRUMENT TAG #</u>	<u>DRAWING</u>	<u>ID #</u>	<u>FUNCTIONAL DESCRIPTION</u>	<u>MFG. NAME</u>	<u>MODEL / CATALOG #</u>
PA-VAP-101	9517-PID-102	11	Vaporizer Relief Stack Cap	Anthes Weather Cap	WC 5
PA-VAP-102	9517-PID-102	12	Vaporizer Relief Valve Pipe Away Adapter	Rego	3135-10
PRV-T1-1	9517-PID-101	72	Tank 1 Primary Relief Valve 1		
PRV-T1-2	9517-PID-101	73	Tank 1 Primary Relief Valve 2		
PRV-T1-3	9517-PID-101	74	Tank 1 Primary Relief Valve 3		
PRV-T1-4	9517-PID-101	75	Tank 1 Primary Relief Valve 4		
PRV-T2-1	9517-PID-101	76	Tank 2 Primary Relief Valve 1		
PRV-T2-2	9517-PID-101	77	Tank 2 Primary Relief Valve 2		
PRV-T2-3	9517-PID-101	78	Tank 2 Primary Relief Valve 3		
PRV-T2-4	9517-PID-101	79	Tank 2 Primary Relief Valve 4		



	<b>LPG MAINTENANCE PROCEDURE</b>	Procedure No: <b>GF-MP-006</b>
	<b>INSPECTING AND REPLACING PRESSURE SAFETY RELIEF VALVES</b>	Published Date: <b>01/18/2022</b>
		Superseded Date: <b>02/01/2022</b>
		Approved By: <b>T. Kennedy</b>

<u>INSTRUMENT TAG #</u>	<u>DRAWING</u>	<u>ID #</u>	<u>FUNCTIONAL DESCRIPTION</u>	<u>MFG. NAME</u>	<u>MODEL / CATALOG #</u>
PSV-TA-101	9517-PID-101	71	Natural Gas Hydrostatic Relief Valve # 1	Rego	3129U w/ 3129-10
PSV-TA-102	9517-PID-101	70	Natural Gas Hydrostatic Relief Valve # 2	Rego	3129U w/ 3129-10
PSV-TA-103	9517-PID-101	27	Propane Vapor Line Hydrostatic Relief Valve # 1	Rego	3129U w/ 3129-10
PSV-TA-104	9517-PID-101	55	Propane Vapor Line Hydrostatic Relief Valve # 2	Rego	3129U w/ 3129-10
PSV-TA-105	9517-PID-101	54	Propane Liquid Line Hydrostatic Relief Valve # 1	Rego	3129U w/ 3129-10
PSV-TA-106	9517-PID-101	53	Propane Liquid Line Hydrostatic Relief Valve # 2	Rego	3129U w/ 3129-10
PSV-VAP-101	9517-PID-101	22	Propane Vapor to Blender Hydrostatic Relief Valve	Rego	3129U w/ 3129-10
PSV-AIR-101	9517-PID-102	2	Process Air Tank Relief Valve	Kunkle	6283FEV01
PSV-FTS-101	9517-PID-103	4	Hydrostatic Relief Valve (FTS Liquid Line)	Rego	3125L
PSV-FTS-103	9517-PID-103	13	Hydrostatic Relief Valve (FTS Vapor Line)	Rego	3125L
PSV-MIX-101	9517-PID-105	70	QT Inlet Relief Valve	Fisher	H120-60

### VIII. PRE-WORK PROCEDURE

- A. Start a job brief and discuss potential concerns.
- B. Walk down valves to be removed, and document on job brief hazards to prepare for.
- C. Notify gas control that relief valve replacement is ready to begin.
- D. Record valve replacement and date below.
- E. Begin at the first valve listed, replacing individual valves in sequence. Ensure slide valve is on relief valve 1 blow down chamber between slide valve and relief valve.
- F. Once pressure is at 0, replace relief valve.
- G. Replace only one valve at a time.
- H. Record valve replacement and date below.

<u>INSTRUMENT TAG #</u>	<u>DRAWING</u>	<u>ID #</u>	<u>LOCATION / FUNCTIONAL DESCRIPTION</u>	<u>REPLACED</u>	<u>DATE</u>
PA-VAP-101	9517-PID-102	11	Vaporizer Relief Stack Cap	Y <input type="checkbox"/> N <input type="checkbox"/>	
PA-VAP-102	9517-PID-102	12	Vaporizer Relief Valve Pipe Away Adapter	Y <input type="checkbox"/> N <input type="checkbox"/>	



**LPG MAINTENANCE PROCEDURE**

**INSPECTING AND REPLACING PRESSURE SAFETY RELIEF VALVES**

Procedure No: **GF-MP-006**

Published Date: **01/18/2022**

Superseded Date: **02/01/2022**

Approved By: **T. Kennedy**

INSTRUMENT TAG #	DRAWING	ID #	LOCATION / FUNCTIONAL DESCRIPTION	REPLACED	DATE
PRV-T1-1	9517-PID-101	72	Tank #1 - 1	Y <input type="checkbox"/> N <input type="checkbox"/>	
PRV-T1-2	9517-PID-101	73	Tank #1 - 2	Y <input type="checkbox"/> N <input type="checkbox"/>	
PRV-T1-3	9517-PID-101	74	Tank #1 - 3	Y <input type="checkbox"/> N <input type="checkbox"/>	
PRV-T1-4	9517-PID-101	75	Tank #1 - 4	Y <input type="checkbox"/> N <input type="checkbox"/>	
PRV-T2-1	9517-PID-101	76	Tank #2 - 1	Y <input type="checkbox"/> N <input type="checkbox"/>	
PRV-T2-2	9517-PID-101	77	Tank #2 - 2	Y <input type="checkbox"/> N <input type="checkbox"/>	
PRV-T2-3	9517-PID-101	78	Tank #2 - 3	Y <input type="checkbox"/> N <input type="checkbox"/>	
PRV-T2-4	9517-PID-101	79	Tank #2 - 4	Y <input type="checkbox"/> N <input type="checkbox"/>	
PSV-TA-101	9517-PID-101	71	Natural Gas Hydrostatic Relief Valve # 1	Y <input type="checkbox"/> N <input type="checkbox"/>	
PSV-TA-102	9517-PID-101	70	Natural Gas Hydrostatic Relief Valve # 2	Y <input type="checkbox"/> N <input type="checkbox"/>	
PSV-TA-103	9517-PID-101	27	Propane Vapor Line Hydrostatic Relief Valve # 1	Y <input type="checkbox"/> N <input type="checkbox"/>	
PSV-TA-104	9517-PID-101	55	Propane Vapor Line Hydrostatic Relief Valve # 2	Y <input type="checkbox"/> N <input type="checkbox"/>	
PSV-TA-105	9517-PID-101	54	Propane Liquid Line Hydrostatic Relief Valve # 1	Y <input type="checkbox"/> N <input type="checkbox"/>	
PSV-TA-106	9517-PID-101	53	Propane Liquid Line Hydrostatic Relief Valve # 2	Y <input type="checkbox"/> N <input type="checkbox"/>	
PSV-VAP-101	9517-PID-101	22	Propane Vapor to Blender Hydrostatic Relief Valve	Y <input type="checkbox"/> N <input type="checkbox"/>	
PSV-AIR-101	9517-PID-102	2	Process Air Tank Relief Valve	Y <input type="checkbox"/> N <input type="checkbox"/>	
PSV-FTS-101	9517-PID-103	4	Hydrostatic Relief Valve (FTS Liquid Line)	Y <input type="checkbox"/> N <input type="checkbox"/>	
PSV-FTS-103	9517-PID-103	13	Hydrostatic Relief Valve (FTS Vapor Line)	Y <input type="checkbox"/> N <input type="checkbox"/>	
PSV-MIX-101	9517-PID-105	70	QT Inlet Relief Valve	Y <input type="checkbox"/> N <input type="checkbox"/>	

Corrective action notes: \_\_\_\_\_

\_\_\_\_\_

Check Performed By: \_\_\_\_\_ Date: \_\_\_\_\_

Reviewed By: \_\_\_\_\_ Date: \_\_\_\_\_

MP #	DEVICE CODE	EQUIP. CODE	ID CODE	INSTRUMENT TAG #	REFERENCE DRAWING No.	DRAWING ID #	FUNCTIONAL DESCRIPTION	MANUFACTURER NAME	MODEL / CATALOG NUMBER	CONNECT SIZE IN	CONNECT SIZE OUT	CONNECT TYPE
GF-MP-026	ESV	FTS	101	ESV-FTS-101	9517-PID-103	11	Emergency Shutoff Valve	Fisher	N550 w/ P327D	1.25	1.25	FNPT
GF-MP-017	FCV	FTS	101	FCV-FTS-101	9517-PID-103	7	Flow Control Valve (FTS Liquid Line)	Wheatley	822-023072-131	2	2	FNPT
GF-MP-017	FCV	FTS	102	FCV-FTS-102	9517-PID-103	15	Flow Control Valve (FTS Vapor Line)	Fisher	F105	1.25	1.25	FNPT
GF-MP-017	FCV	IAS	101	FCV-IAS-101	9517-PID-101	8	Flow Control Valve for (FCV-TANK1-101)	Schraeder-Bellows	SPF200B	0.125	0.125	FNPT
GF-MP-019	FCV	IAS	101	FCV-IAS-101	9517-PID-101	9	Flow Control Valve for (FCV-TANK2-101)	Schraeder-Bellows	SPF200B	0.125	0.125	FNPT
GF-MP-017	FCV	IAS	101	FCV-IAS-101	9517-PID-101	12	Flow Control Valve for (FCV-TANK1-102)	Schraeder-Bellows	SPF200B	0.125	0.125	FNPT
GF-MP-017	FCV	IAS	101	FCV-IAS-101	9517-PID-101	13	Flow Control Valve for (FCV-TANK2-102)	Schraeder-Bellows	SPF200B	0.125	0.125	FNPT
GF-MP-018	FCV	IAS	101	FCV-IAS-101	9517-PID-101	20	Flow Control Valve for (FCV-TANK1-103)	Schraeder-Bellows	SPF200B	0.125	0.125	FNPT
GF-MP-017	FCV	IAS	101	FCV-IAS-101	9517-PID-101	21	Flow Control Valve for (FCV-TANK2-103)	Schraeder-Bellows	SPF200B	0.125	0.125	FNPT
GF-MP-017	FCV	IAS	102	FCV-IAS-102	9517-PID-101	28	IAS Solenoid Valve for Tank #1	Parker Skinner	71315SN2MNJ1N0H111C2	0.25	0.25	FNPT
GF-MP-053	FCV	IAS	102	FCV-IAS-102	9517-PID-101	28	IAS Solenoid Valve for Tank #1	Parker Skinner	71315SN2MNJ1N0H111C2	0.25	0.25	FNPT
GF-MP-017	FCV	IAS	103	FCV-IAS-103	9517-PID-101	29	IAS Solenoid Valve for Tank #2	Parker Skinner	71315SN2MNJ1N0H111C2	0.25	0.25	FNPT
GF-MP-053	FCV	IAS	103	FCV-IAS-103	9517-PID-101	29	IAS Solenoid Valve for Tank #2	Parker Skinner	71315SN2MNJ1N0H111C2	0.25	0.25	FNPT
GF-MP-053	FCV	IAS	119	FCV-IAS-103	9517-PID-104a	1	Instrument Air Main Solenoid Valve	Parker Skinner	71315SN2MNJ1N0H111C2	0.5	0.5	FNPT
GF-MP-017	FCV	IAS	104	FCV-IAS-104	9517-PID-101	32	IAS Solenoid Valve for (FCV-NG-103)	Parker Skinner	71315SN2MNJ1N0H111C2	0.25	0.25	FNPT
GF-MP-017	FCV	IAS	105	FCV-IAS-105	9517-PID-101	33	Flow Control Valve for (FCV-NG-103)	Schraeder-Bellows	SPF200B	0.125	0.125	FNPT
GF-MP-017	FCV	IAS	106	FCV-IAS-106	12023-PID-102-R03	27	IAS Solenoid Valve for (FCV-VAP-102)	Parker Skinner	71315SN2MNJ1N0H111C2	0.25	0.25	FNPT
GF-MP-017	FCV	IAS	107	FCV-IAS-107	12023-PID-102-R03	28	IAS Flow Control Valve for (FCV-VAP-102)	Schraeder-Bellows	SPF200B	0.125	0.125	FNPT
GF-MP-017	FCV	IAS	108	FCV-IAS-108	9517-PID-105	7	Control Air Solenoid Valve for (FCV-MIX-121)	Parker Skinner	71315SN2MNJ1N0H111C2	0.25	0.25	FNPT
GF-MP-017	FCV	IAS	109	FCV-IAS-109	9517-PID-105	9	Control Air Flow Control Valve for (FCV-MIX-101)	Schrader-Bellows	SPF400B	0.25	0.25	FNPT
GF-MP-017	FCV	IAS	110	FCV-IAS-110	9517-PID-105	8	Control Air Solenoid Valve for (FCV-MIX-101)	Parker Skinner	71315SN2MNJ1N0H111C2	0.25	0.25	FNPT
GF-MP-017	FCV	IAS	111	FCV-IAS-111	9517-PID-105	32	Control Air Solenoid Valve for (FCV-MIX-111)	Parker Skinner	71315SN2MNJ1N0H111C2	0.25	0.25	FNPT
GF-MP-017	FCV	IAS	112	FCV-IAS-112	9517-PID-105	50	Control Air Flow Control Valve for (FCV-MIX-106)	Schrader-Bellows	SPF400B	0.25	0.25	FNPT
GF-MP-017	FCV	IAS	113	FCV-IAS-113	9517-PID-105	49	Control Air Solenoid Valve for (FCV-MIX-106)	Parker Skinner	71315SN2MNJ1N0H111C2	0.25	0.25	FNPT
GF-MP-017	FCV	IAS	114	FCV-IAS-114	9517-PID-105	56	Control Air Flow Control Valve for (FCV-MIX-108)	Schrader-Bellows	SPF400B	0.25	0.25	FNPT
GF-MP-017	FCV	IAS	115	FCV-IAS-115	9517-PID-105	55	Control Air Solenoid Valve for (FCV-MIX-108)	Parker Skinner	71315SN2MNJ1N0H111C2	0.25	0.25	FNPT
GF-MP-017	FCV	IAS	116	FCV-IAS-116	9517-PID-105	61	Control Air Flow Control Valve for (FCV-MIX-104)	Schrader-Bellows	SPF400B	0.25	0.25	FNPT
GF-MP-017	FCV	IAS	117	FCV-IAS-117	9517-PID-105	59	Control Air Solenoid Valve for (FCV-MIX-104)	Parker Skinner	71315SN2MNJ1N0H111C2	0.25	0.25	FNPT
GF-MP-017	FCV	IAS	118	FCV-IAS-118	9517-PID-105	5	Control Air Solenoid Valve for (FCV-MIX-121)	Parker Skinner	71315SN2MNJ1N0H111C2	0.25	0.25	FNPT
GF-MP-017	FCV	IAS	119	FCV-IAS-119	9517-PID-104	1	Instrument Air Main Solenoid Valve	Parker Skinner	71315SN2MNJ1N0H111C2	0.5	0.5	FNPT
GF-MP-017	FCV	IAS	120	FCV-IAS-120	9517-PID-105	3	Control Air Solenoid Valve for (FCV-MIX-123)	Parker Skinner	71315SN2MNJ1N0H111C2	0.25	0.25	FNPT
GF-MP-017	FCV	IAS	121	FCV-IAS-121	9517-PID-105	2	Control Air Flow Control Valve for (FCV-MIX-123)	Schrader-Bellows	SPF400B	0.25	0.25	FNPT

MP #	DEVICE CODE	EQUIP. CODE	ID CODE	INSTRUMENT TAG #	REFERENCE DRAWING No.	DRAWING ID #	FUNCTIONAL DESCRIPTION	MANUFACTURER NAME	MODEL / CATALOG NUMBER	CONNECT SIZE IN	CONNECT SIZE OUT	CONNECT TYPE
GF-MP-017	FCV	IAS	122	FCV-IAS-122	12023-PID-102-R03	20	IAS Solenoid Valve for (FCV-VAP-101)	Parker Skinner	71315SN2MNJ1N0H111C2	0.25	0.25	FNPT
GF-MP-017	FCV	IAS	123	FCV-IAS-123	12023-PID-102-R03	21	IAS Flow Control Valve for (FCV-VAP-101)	Schraeder-Bellows	SPF200B	0.125	0.125	FNPT
GF-MP-017	FCV	MIX	101	FCV-MIX-101	9517-PID-105	17	Blender Propane Vapor Inlet Actuated Ball Valve	Kuka/Triac	CBA15BGLN/2R200SR--LT	2	2	ANSI 150#
GF-MP-053	FCV	MIX	101	FCV-MIX-101	9517-PID-105a	17	Blender Propane Vapor Inlet Actuated Ball Valve	Kuka/Triac	CBA15BGLN/2R200SR--LT	2	2	ANSI 150#
GF-MP-017	FCV	MIX	102	FCV-MIX-102	9517-PID-105	20	Blender Propane Vapor Pressure Control Valve #2	Fisher	V150 - V Ball	2	2	ANSI 150#
GF-MP-017	FCV	MIX	103	FCV-MIX-103	9517-PID-105	29	Propane Vapor Check Valve	Wheatley	510-025027-121	2	2	ANSI 150#
GF-MP-017	FCV	MIX	104	FCV-MIX-104	9517-PID-105	76	Process Air Inlet Actuated Ball Valve #1	Kuka/Triac	CBA15BGLN/2R200SR--LT	2	2	ANSI 150#
GF-MP-053	FCV	MIX	104	FCV-MIX-104	9517-PID-105b	76	Process Air Inlet Actuated Ball Valve #1	Kuka/Triac	CBA15BGLN/2R200SR--LT	2	2	ANSI 150#
GF-MP-017	FCV	MIX	106	FCV-MIX-106	9517-PID-105	77	Process Air Inlet Actuated Ball Valve # 2	Kuka/Triac	CBA15BGLN/2R200SR--LT	2	2	ANSI 150#
GF-MP-053	FCV	MIX	106	FCV-MIX-106	9517-PID-105c	77	Process Air Inlet Actuated Ball Valve # 2	Kuka/Triac	CBA15BGLN/2R200SR--LT	2	2	ANSI 150#
GF-MP-017	FCV	MIX	108	FCV-MIX-108	9517-PID-105	93	Blender Air Supply Vent Valve (Double Block - Normally Open)	Jamesbury/Triac	9FB223600XT/2R200SR--LT	1	1	FNPT
GF-MP-053	FCV	MIX	108	FCV-MIX-108	9517-PID-105c	93	Blender Air Supply Vent Valve (Double Block - Normally Open)	Jamesbury/Triac	Full Port, Fire Rated, Carbon Steel Body, Stainless Steel Trim	1	1	FNPT
GF-MP-017	FCV	MIX	110	FCV-MIX-110	9517-PID-105	89	Process Air Back Check Valve	Wheatley	510-025027-121	2	2	ANSI 150#
GF-MP-017	FCV	MIX	111	FCV-MIX-111	9517-PID-105	78	Process Air Pressure Control Valve	Fisher	V150 - V Ball	1.5	1.5	ANSI 150#
GF-MP-017	FCV	MIX	121	FCV-MIX-121	9517-PID-105	45	Mixed Gas Outlet Actuated Flow Control Valve	Kuka/Triac	CBA15BGLN/2R300SR--LT	3	3	ANSI 150#
GF-MP-053	FCV	MIX	121	FCV-MIX-121	9517-PID-105b	45	Mixed Gas Outlet Actuated Flow Control Valve	Kuka/Triac	CBA15BGLN/2R300SR--LT	3	3	ANSI 150#
GF-MP-017	FCV	MIX	122	FCV-MIX-122	9517-PID-105	38	Propane Vapor from Tanks Header Check Valve	Wheatley	822-013072-131	1	1	FNPT
GF-MP-017	FCV	MIX	123	FCV-MIX-123	9517-PID-105	31	Propane Vapor from Tanks Vapor Header Ball Valve	Jamesbury	9FB3600XT	1	1	FNPT
GF-MP-053	FCV	MIX	123	FCV-MIX-123	9517-PID-105a	31	Propane Vapor from Tanks Vapor Header Ball Valve	Jamesbury	9FB3600XT	1	1	FNPT
GF-MP-017	FCV	NG	101	FCV-NG-101	9517-PID-101	35	Natural Gas Pad Check Valve #1	Wheatley	510-025027-121	2	2	ANSI 150#
GF-MP-017	FCV	NG	102	FCV-NG-102	9517-PID-101	69	Natural Gas Pad Check Valve #2	Wheatley	510-025027-121	2	2	ANSI 150#
GF-MP-017	FCV	NG	103	FCV-NG-103	9517-PID-101	38	Natural Gas Pad Actuated Ball Valve	Kuka/Triac	CBA15BGLN/2R200SR--LT	2	2	ANSI 150#
GF-MP-053	FCV	NG	103	FCV-NG-103	9517-PID-101b	38	Natural Gas Pad Actuated Ball Valve	Kuka/Triac	CBA15BGLN/2R200SR--LT	2	2	ANSI 150#
GF-MP-017	FCV	QT	101	FCV-QT-101	9517-PID-105	66	Solenoid Valve Mixed Gas to S.G. Transducer	Parker Skinner	71216SN2FU00N0H111C2	0.25	0.25	FNPT
GF-MP-017	FCV	TANK1	101	FCV-TANK1-101	9517-PID-101	14	Actuated Internal Valve - Propane Liquid Out Line, Propane Storage Tank No. 1	Rego	A3213R300 w/ A3213PA	3	3	MNPT/FNPT
GF-MP-017	FCV	TANK1	102	FCV-TANK1-102	9517-PID-101	15	Actuated Internal Valve - Propane Liquid Fill Line, Propane Storage Tank No. 1	Rego	A3212R250 w/A3213PA	2	2	MNPT/FNPT
GF-MP-017	FCV	TANK1	103	FCV-TANK1-103	9517-PID-101	16	Actuated Internal Valve - Propane Vapor Line, Propane Storage Tank No. 1	Rego	A3212R250 w/A3213PA	2	2	MNPT/FNPT
GF-MP-017	FCV	TANK2	101	FCV-TANK2-101	9517-PID-101	17	Actuated Internal Valve - Propane Liquid Out Line, Propane Storage Tank No. 2	Rego	A3213R300 w/ A3213PA	3	3	MNPT/FNPT
GF-MP-017	FCV	TANK2	102	FCV-TANK2-102	9517-PID-101	18	Actuated Internal Valve - Propane Liquid Fill Line, Propane Storage Tank No. 2	Rego	A3212R250 w/A3213PA	2	2	MNPT/FNPT
GF-MP-017	FCV	TANK2	103	FCV-TANK2-103	9517-PID-101	51	Actuated Internal Valve - Propane Vapor Line, Propane Storage Tank No. 2	Rego	A3212R250 w/A3213PA	2	2	MNPT/FNPT
GF-MP-017	FCV	VAP	101	FCV-VAP-101	12023-PID-102-R03	19	Vaporizer Discharge Actuated Ball Valve	Kuka/Triac	CBA30BGLN/2R300SR--LT	3	3	ANSI 300#
GF-MP-053	FCV	VAP	101	FCV-VAP-101	12023-PID-102-R03	19	Vaporizer Discharge Actuated Ball Valve	Kuka/Triac	CBA30BGLN/2R300SR--LT	3	3	ANSI 300#

MP #	DEVICE CODE	EQUIP. CODE	ID CODE	INSTRUMENT TAG #	REFERENCE DRAWING No.	DRAWING ID #	FUNCTIONAL DESCRIPTION	MANUFACTURER NAME	MODEL / CATALOG NUMBER	CONNECT SIZE IN	CONNECT SIZE OUT	CONNECT TYPE
GF-MP-017	FCV	VAP	102	FCV-VAP-102	12023-PID-102-R03	36	Vaporizer Discharge Actuated Ball Valve	Kuka/Triac	CBA30BGLN/2R300SR--LT	3	3	ANSI 300#
GF-MP-017	FCV	VAP	102	FCV-VAP-102	9517-PID-101	26	Propane Vapor to Blender Discharge Check Valve	Wheatley	822-013072-131	1	1	FNPT
GF-MP-053	FCV	VAP	102	FCV-VAP-102	12023-PID-102-R03	36	Vaporizer Discharge Actuated Ball Valve	Kuka/Triac	CBA30BGLN/2R300SR--LT	3	3	ANSI 300#
GF-MP-002	FT	MIX	101	FT-MIX-101	9517-PID-105	21	Blender Propane Vapor Flow Transmitter	Hoffer	HO2X2-15-CB-1MC3PAX-F1SS-X / CAT1-3/O-7-D-X	2	2	ANSI 150#
GF-MP-002	FT	MIX	102	FT-MIX-102	9517-PID-105	79	Blender Process Air Supply Flow Transmitter	Hoffer	HO2X2-15-CB-1MC3PAX-F1SS-X / CAT3-2-1-1-DC-X-2/O-x	2	2	ANSI 150#
GF-MP-032	HV	AIR	101	HV AIR 101	12023-PID-102-R03	10	Process Air Compressor Discharge Isolation Valve	Kuka	CBA15BGLN	3	3	ANSI 150#
GF-MP-032	HV	AIR	102	HV AIR 102	12023-PID-102-R03	7	Process Air Tank Drain Valve	RUB	S92EB8	1	1	FNPT
GF-MP-032	HV	AIR	103	HV AIR 103	12023-PID-102-R03	5	Process Air Tank Instrument Isolation Valve	Dragon	10M517G	0.5	0.5	MXFNPT
GF-MP-032	HV	AIR	104	HV AIR 104	12023-PID-102-R03	2	Process Air Compressor Discharge Isolation Valve	Kuka	CBA15BGLN	3	3	ANSI 150#
GF-MP-032	HV	AIR	105	HV AIR 105	12023-PID-102-R03	1	Process Air Compressor Discharge Isolation Valve	Kuka	CBA15BGLN	3	3	ANSI 150#
GF-MP-032	HV	IAS	104	HV IAS 104	12023-PID-102-R03	29	IAS Vented Ball Valve for (FCV-VAP-102)	RUB	S93B41	0.25	0.25	FNPT
GF-MP-032	HV	IAS	118	HV IAS 118	12023-PID-102-R03	22	IAS Vented Ball Valve for (FCV-VAP-101)	RUB	S93B41	0.25	0.25	FNPT
GF-MP-032	HV	VAP	101	HV VAP 101	12023-PID-102-R03	26	Vaporizer Inlet Isolation Ball Valve	Kuka	CBA30BGLN	2	2	ANSI 300#
GF-MP-032	HV	VAP	102	HV VAP 102	12023-PID-102-R03	16	Instrument Isolation Ball Valve	Dragon	10M517G	0.5	0.5	MNPT x FNPT
GF-MP-032	HV	VAP	103	HV VAP 103	12023-PID-102-R03	24	Vaporizer 1 Inlet Isolation Ball Valve	Titan	YS-62-CS	2	2	ANSI 300#
GF-MP-032	HV	VAP	104	HV VAP 104	12023-PID-102-R03	38	Vaporizer 2 Inlet Isolation Ball Valve	Kuka	CBA30BGLN	2	2	ANSI 300#
GF-MP-032	HV	VAP	105	HV VAP 105	12023-PID-102-R03	33	Instrument Isolation Ball Valve	Dragon	10M517G	0.5	0.5	MNPT x FNPT
GF-MP-032	HV	FTS	101	HV-FTS-101	9517-PID-103	2	Angle Valve (FTS Liquid Line)	Squib-Taylor	AL317P	2	2	FNPT
GF-MP-032	HV	FTS	102	HV-FTS-102	9517-PID-103	8	Strainer Blow Down Valve	Jamesbury	9FB3600XT	1	1	FNPT
GF-MP-032	HV	FTS	103	HV-FTS-103	9517-PID-103	3	Isolation Ball Valve (FTS Liquid Line)	Jamesbury	9FB3600XT	2	2	FNPT
GF-MP-032	HV	FTS	104	HV-FTS-104	9517-PID-103	10	Angle Valve (FTS Vapor Line)	Squibb-Taylor	AL313P	1.25	1.25	FNPT
GF-MP-032	HV	FTS	105	HV-FTS-105	9517-PID-103	12	Isolation Ball Valve (FTS Vapor Line)	Jamesbury	9FB3600XT	2	2	FNPT
GF-MP-032	HV	IAS	101	HV-IAS-101	9517-PID-101	10	Vented Ball Valve for (FCV-TANK1-101)	Apollo	7K-101-27	0.25	0.25	FNPT
GF-MP-032	HV	IAS	101	HV-IAS-101	9517-PID-101	11	Vented Ball Valve for (FCV-TANK2-101)	Apollo	7K-101-27	0.25	0.25	FNPT
GF-MP-032	HV	IAS	101	HV-IAS-101	9517-PID-101	19	Vented Ball Valve for (FCV-TANK2-102)	Apollo	7K-101-27	0.25	0.25	FNPT
GF-MP-032	HV	IAS	101	HV-IAS-101	9517-PID-101	24	Vented Ball Valve for (FCV-TANK1-103)	Apollo	7K-101-27	0.25	0.25	FNPT
GF-MP-032	HV	IAS	101	HV-IAS-101	9517-PID-101	25	Vented Ball Valve for (FCV-TANK2-103)	Apollo	7K-101-27	0.25	0.25	FNPT
GF-MP-032	HV	IAS	101	HV-IAS-101	9517-PID-101	52	Vented Ball Valve for (FCV-TANK1-102)	Apollo	7K-101-27	0.25	0.25	FNPT
GF-MP-032	HV	IAS	102	HV-IAS-102	9517-PID-101	64	Vented Ball Valve for (FCV-NG-103)	RUB	S93B41	0.25	0.25	FNPT
GF-MP-032	HV	IAS	105	HV-IAS-105	9517-PID-103	16	Pneumatic Isolation for ESV Valve	Rub	S93B41	0.25	0.25	FNPT
GF-MP-032	HV	IAS	108	HV-IAS-108	9517-PID-105	6	Control Air Hand Valve for (FCV-MIX-121)	Rub	S93B41	0.25	0.25	FNPT
GF-MP-032	HV	IAS	109	HV-IAS-109	9517-PID-105	10	Control Air Hand Valve for (FCV-MIX-101)	Rub	S93B41	0.25	0.25	FNPT

MP #	DEVICE CODE	EQUIP. CODE	ID CODE	INSTRUMENT TAG #	REFERENCE DRAWING No.	DRAWING ID #	FUNCTIONAL DESCRIPTION	MANUFACTURER NAME	MODEL / CATALOG NUMBER	CONNECT SIZE IN	CONNECT SIZE OUT	CONNECT TYPE
GF-MP-032	HV	IAS	110	HV-IAS-110	9517-PID-105	33	Control Air Hand Valve for (FCV-MIX-111)	Rub	S93B41	0.25	0.25	FNPT
GF-MP-032	HV	IAS	111	HV-IAS-111	9517-PID-105	51	Control Air Hand Valve for (FCV-MIX-106)	Rub	S93B41	0.25	0.25	FNPT
GF-MP-032	HV	IAS	112	HV-IAS-112	9517-PID-105	54	Control Air Hand Valve for (FCV-MIX-108)	Rub	S93B41	0.25	0.25	FNPT
GF-MP-032	HV	IAS	113	HV-IAS-113	9517-PID-105	60	Control Air Hand Valve for (FCV-MIX-104)	Rub	S93B41	0.25	0.25	FNPT
GF-MP-032	HV	IAS	114	HV-IAS-114	9517-PID-105	4	Control Air Hand Valve for (FCV-MIX-121)	Rub	S93B41	0.25	0.25	FNPT
GF-MP-032	HV	IAS	115	HV-IAS-115	9517-PID-104	6	Instrument Air Compressor Discharge Valve	RUB	S92DB8	0.5	0.5	FNPT
GF-MP-032	HV	IAS	116	HV-IAS-116	9517-PID-104	7	Instrument Air Isolation Ball Valve	RUB	S92DB8	0.5	0.5	FNPT
GF-MP-032	HV	IAS	117	HV-IAS-117	9517-PID-105	1	Control Air Hand Valve for (FCV-MIX-123)	Rub	S93B41	0.25	0.25	FNPT
GF-MP-032	HV	MIX	101	HV-MIX-101	9517-PID-105	12	Blender Propane Supply Blowdown Valve	Jamesbury	9FB3600XT	0.5	0.5	FNPT
GF-MP-032	HV	MIX	102	HV-MIX-102	9517-PID-105	85	Insturment Hand Valve for PT & PI-MIX-103	Dragon	10M517G	0.5	0.5	MNPT/FNPT
GF-MP-032	HV	MIX	103	HV-MIX-103	9517-PID-105	18	Blender Propane Vapor Insturment Hand Valve for PI-MIX & PT-MIX 102	Dragon	10M517G	0.5	0.5	MNPT/FNPT
GF-MP-032	HV	MIX	105	HV-MIX-105	9517-PID-105	26	Blender Air Supply Insturment Hand Valve for PI-MIX & PT-MIX-105	Dragon	10M517G	0.5	0.5	MNPT/FNPT
GF-MP-032	HV	MIX	106	HV-MIX-106	9517-PID-105	92	Blender Strainer Blowdown Valve Process Air (ST-MIX-102)	Jamesbury	9FB3600XT	0.5	0.5	FNPT
GF-MP-032	HV	MIX	108	HV-MIX-108	9517-PID-105	86	Blender Air Supply Insturment Hand Valve for PT & PI-MIX-104	Dragon	10M517G	0.5	0.5	MNPT/FNPT
GF-MP-032	HV	MIX	109	HV-MIX-109	9517-PID-105	65	Blender Air Supply Blowdown Valve	Jamesbury	9FB3600XT	0.5	0.5	FNPT
GF-MP-032	HV	MIX	110	HV-MIX-110	9517-PID-105	44	Mixer Instrument Hand Valve for PT & PI-MIX-106	Dragon	10M517G	0.5	0.5	MNPT/FNPT
GF-MP-032	HV	MIX	111	HV-MIX-111	9517-PID-105	57	Hand Valve (Mixed Gas to Densitometer)	Dragon	10M517G	0.5	0.5	MNPT/FNPT
GF-MP-032	HV	MIX	112	HV-MIX-112	9517-PID-105	47	Blender Instrument Hand Valve for PT -MIX-107	Dragon	10M517G	0.5	0.5	MNPT/FNPT
GF-MP-032	HV	MIX	119	HV-MIX-119	9517-PID-105	28	Blowdown valve for (ST MIX 101)	Jamesbury	9FB3600XT	0.5	0.5	FNPT
GF-MP-032	HV	NG	101	HV-NG-101	9517-PID-101	36	Natural Gas Pad Inlet Ball Valve	Kuka	CBA15BGLN	2	2	ANSI 150#
GF-MP-032	HV	NG	102	HV-NG-102	9517-PID-101	66	Natural Gas Pad Gauge Isolation Valve # 1	Dragon	10M517G	0.5	0.5	MNPT x FNPT
GF-MP-032	HV	NG	103	HV-NG-103	9517-PID-101	67	Natural Gas Pad Gauge Isolation Valve # 2	Dragon	10M517G	0.5	0.5	MNPT x FNPT
GF-MP-032	HV	QT	101	HV-QT-101	9517-PID-105	62	Hand Valve Test Port for Air Supply to S.G. Transducer	Jamesbury	9FB3600XT	0.25	0.25	FNPT
GF-MP-032	HV	TA	105	HV-TA-105	9517-PID-101	68	Propane Vapor Line 3-Way Ball Valve for Hydrostatic Relief Valves	Apollo	76-603	0.5	0.5	FNPT
GF-MP-032	HV	TA	106	HV-TA-106	9517-PID-101	56	Propane Vapor Line 3-Way Ball Valve for Hydrostatic Relief Valves	Apollo	76-603	0.5	0.5	FNPT
GF-MP-032	HV	TA	107	HV-TA-107	9517-PID-101	23	Propane Liquid Line 3-Way Ball Valve for Hydrostatic Relief Valves	Apollo	76-603	0.5	0.5	FNPT
GF-MP-032	HV	TANK1	101	HV-TANK1-101	9517-PID-101	61	Isolation Ball Valve - Liquid Out Line, Propane Storage Tank No. 1	Kuka	CBA30BG	3	3	ANSI 300#
GF-MP-032	HV	TANK1	102	HV-TANK1-102	9517-PID-101	62	Isolation Ball Valve - Liquid Fill Line Propane, Storage Tank No. 1	Kuka	CBA30BG	2	2	ANSI 300#
GF-MP-032	HV	TANK1	103	HV-TANK1-103	9517-PID-101	58	Isolation Ball Valve - Natural Gas Line, Propane Storage Tank No. 1	Kuka	CBA30BG	2	2	ANSI 300#
GF-MP-032	HV	TANK1	104	HV-TANK1-104	9517-PID-101	59	Isolation Ball Valve - Propane Vapor Line Propane Storage Tank No. 1	Kuka	CBA30BG	2	2	ANSI 300#
GF-MP-032	HV	TANK1	105	HV-TANK1-105	9517-PID-101	41	Instrument Isolation Valve for LI TANK1 102, Propane Storage Tank No. 1	Anderson Greenwood	H5VIS22A	0.25	0.25	MNPT x FNPT
GF-MP-032	HV	TANK1	106	HV-TANK1-106	9517-PID-101	48	Instrument Isolation Valve for PI & PT TANK1 101, Propane Storage Tank No. 1	Anderson Greenwood	H5VIS22A	0.25	0.25	MNPT x FNPT



MP #	DEVICE CODE	EQUIP. CODE	ID CODE	INSTRUMENT TAG #	REFERENCE DRAWING No.	DRAWING ID #	FUNCTIONAL DESCRIPTION	MANUFACTURER NAME	MODEL / CATALOG NUMBER	CONNECT SIZE IN	CONNECT SIZE OUT	CONNECT TYPE
GF-MP-032	HV	TANK2	101	HV-TANK2-101	9517-PID-101	57	Isolation Ball Valve - Liquid Out Line, Propane Storage Tank No. 2	Kuka	CBA30BG	3	3	ANSI 300#
GF-MP-032	HV	TANK2	102	HV-TANK2-102	9517-PID-101	63	Isolation Ball Valve - Liquid Fill Line Propane, Storage Tank No. 2	Kuka	CBA30BG	2	2	ANSI 300#
GF-MP-032	HV	TANK2	103	HV-TANK2-103	9517-PID-101	60	Isolation Ball Valve - Natural Gas Line, Propane Storage Tank No. 2	Kuka	CBA30BG	2	2	ANSI 300#
GF-MP-032	HV	TANK2	104	HV-TANK2-104	9517-PID-101	30	Isolation Ball Valve - Propane Vapor Line Propane Storage Tank No. 2	Kuka	CBA30BG	2	2	ANSI 300#
GF-MP-032	HV	TANK2	105	HV-TANK2-105	9517-PID-101	5	Combo Valve for Propane Storage Tank No. 2	Marshall Excelsior	MEJ415	0.75	0.25	MNPT x FNPT
GF-MP-032	HV	VAP	103	HV-VAP-103	9517-PID-101	31	Propane Vapor to Blender Discharge Isolation Ball Valve	Jamesbury	9FB3600XT	1	1	FNPT
GF-MP-017	I/Z	MIX	101	I/Z-MIX-101	9517-PID-105	63	Current to Position Transmitter for (FCV-MIX-111)	Fisher	DVC 6200	NA	NA	NA
GF-MP-017	I/Z	MIX	103	I/Z-MIX-103	9517-PID-105	11	Current to Position Transmitter for (FCV-MIX-102)	Fisher	DVC 6200	NA	NA	NA
	LI	TANK1	101	LI-TANK1-101	9517-PID-101	49	Level Indicator for Propane Storage Tank No. 1	Taylor	ME3862B / 5331 Adapter	2.5	NA	MNPT
	LI	TANK1	102	LI-TANK1-102	9517-PID-101	43	85% Spit Valve to be Installed on (HV-TANK1-105)	Marshall Excelsior	MEJ402S	0.25	NA	MNPT
	LI	TANK2	101	LI-TANK2-101	9517-PID-101	47	Level Indicator for Propane Storage Tank No. 2	Taylor	ME3862B / 5331 Adapter	2.5	NA	MNPT
	LI	TANK2	102	LI-TANK2-102	9517-PID-101	6	85% Spit Valve to be Installed on (HV-TANK2-105)	Marshall Excelsior	MEJ402S	0.25	NA	MNPT
	LT	TANK1	101	LT-TANK1-101	9517-PID-101	40	Liquid Level Transmitter for Propane Storage Tank No. 1	MTS	MRA2B1B11A1U110.00S	0.75	NA	MNPT
	LT	TANK2	101	LT-TANK2-101	9517-PID-101	2	Liquid Level Transmitter for Propane Storage Tank No. 2	MTS	MRA2B1B11A1U110.00S	0.75	NA	MNPT
GF-MP-032	PA	VAP	101	PA VAP 101	12023-PID-102-R03	13	Vaporizer Relief Stack Cap	Anthes Weather Cap	WC 5	2	NA	NA
GF-MP-033	PA	VAP	102	PA VAP 102	12023-PID-102-R03	14	Vaporizer Relief Valve Pipe Away Adapter	Rego	3135-10	1.25	2	NPT
GF-MP-034	PA	VAP	103	PA VAP 103	12023-PID-102-R03	30	Vaporizer Relief Stack Cap	Anthes Weather Cap	WC 5	2	NA	NA
GF-MP-035	PA	VAP	104	PA VAP 104	12023-PID-102-R03	31	Vaporizer Relief Valve Pipe Away Adapter	Rego	3135-10	1.25	2	NPT
GF-MP-049	PCV	IAS	101	PCV-IAS-101	9517-PID-104	8	Instrument Air Regulator	Control-Air	300-BC	0.25	0.25	NPT
GF-MP-049	PCV	IAS	102	PCV-IAS-102	9517-PID-104	10	Instrument Air Regulator	Control-Air	300-BC	0.25	0.25	NPT
GF-MP-049	PCV	MIX	101	PCV-MIX-101	9517-PID-105	19	Blender Propane Vapor Pressure Control Valve #1	Fisher	1098-EGR	2	2	ANSI 150#
GF-MP-049	PCV	MIX	103	PCV-MIX-103	9517-PID-105	74	Propane-Air to QT Pressure Control Valve	Swagelok	KPR1DRC412A20000	0.5	0.5	FNPT
GF-MP-049	PCV	MIX	109	PCV-MIX-109	9517-PID-105	82	Air Pressure Control Valve	Fisher	1098-EGR	2	2	ANSI 150#
GF-MP-049	PCV	NG	101	PCV-NG-101	9517-PID-101	37	Natural Gas Pad Pressure Regulator	Fisher	627	1	1	FNPT
GF-MP-049	PCV	QT	101	PCV-QT-101	9517-PID-105	72	Pressure Regulator Supply Gas to S.G. Transducer	Fisher	R622-BCF	0.25	0.25	FNPT
GF-MP-036	PE	AIR	101	PE AIR 101	12023-PID-102-R03	11	Process Air Compressor No. 1	Atlas Copco	GA110-6.9-60	NA	3	FNPT
GF-MP-038	PE	AIR	102	PE AIR 102	12023-PID-102-R03	8	Process Air Compressor	Sylvin Tank	TBD	3	3	ANSI 150#
GF-MP-037	PE	AIR	102	PE AIR 102	12023-PID-102-R03	3	Process Air Compressor No. 2	Atlas Copco	GA110-6.9-60	NA	3	FNPT
	PE	VAP	101	PE VAP 101	12023-PID-102-R03	23	Q1650V Vertical Waterbath Vaporizer 1	Algas-SDI	Q1650V	1	2	FNPT
	PE	VAP	102	PE VAP 102	12023-PID-102-R03	37	Q1650V Vertical Waterbath Vaporizer 2	Algas-SDI	Q1650V	1	2	FNPT
	PE	FTS	101	PE-FTS-101	9517-PID-103	6	FTS Bulkhead	Standby Systems	SSI Drawing	1.25	2	FNPT
	PE	FTS	101	PE-FTS-101	9517-PID-103	14	FTS Bulkhead	Standby Systems	SSI Drawing	1.25	2	FNPT

MP #	DEVICE CODE	EQUIP. CODE	ID CODE	INSTRUMENT TAG #	REFERENCE DRAWING No.	DRAWING ID #	FUNCTIONAL DESCRIPTION	MANUFACTURER NAME	MODEL / CATALOG NUMBER	CONNECT SIZE IN	CONNECT SIZE OUT	CONNECT TYPE
	PE	FTS	102	PE-FTS-102	9517-PID-103	1	Liquid Acme Fill Adapter (FTS Liquid Line)	Fisher	ME503-16, ME441F-1	2	3.25	MNPT/ACME
	PE	FTS	104	PE-FTS-104	9517-PID-103	9	Vapor Acme Fill Adapter (FTS Vapor Line)	Fisher	ME233, ME431F-1	1.25	2.25	MNPT/ACME
GF-MP-004	PE	IAS	101	PE-IAS-101	9517-PID-104	4	Instrument Air Compressor	Atlas Copco	GX2-150	NA	NA	NA
	PE	IAS	102	PE-IAS-102	9517-PID-104	5	IAS Dryer and Filter	Stylair	H12N	0.25	0.25	FNPT
	PE	MIX	101	PE-MIX-101	9517-PID-105	53	Static Mixer	Custom	59571	4	4	WELD
	PE	MIX	102	PE-MIX-102	9517-PID-105	58	Inlet Filter for QT	Balston	91S6	0.125	0.125	FNPT
	PE	QT	101	PE-QT-101	9517-PID-105	73	Specific Gravity Transducer	Yokogawa	GD402G-A-E-E/U & GD40T/EJAF3	0.375	0.25	Swagelok
GF-MP-014	PI	AIR	101	PI AIR 101	12023-PID-102-R03	4	Process Air Tank Pressure Indicator	US Gauge	1981 # 150027DM	0.5	0.5	MNPT
GF-MP-014	PI	IAS	101	PI-IAS-101	9517-PID-104	2	Instrument Air Pressure Indicator	Trerice	D83SS2502LA110	0.25	NA	FNPT
GF-MP-014	PI	IAS	102	PI-IAS-102	9517-PID-104	9	Instrument Air Pressure Indicator	Trerice	D83SS2502LA110	0.25	NA	FNPT
GF-MP-014	PI	MIX	102	PI-MIX-102	9517-PID-105	22	Blender Propane Vapor Inlet Pressure Indicator #2	US Gauge	1981 # 150027DM	0.5	NA	MNPT
GF-MP-014	PI	MIX	103	PI-MIX-103	9517-PID-105	75	Blender Air Supply Inlet Pressure Indicator #1	US Gauge	1981 # 150027DM	0.5	NA	MNPT
GF-MP-014	PI	MIX	104	PI-MIX-104	9517-PID-105	80	Blender Air Supply Inlet Pressure Indicator #2	US Gauge	1981 # 150027DM	0.5	NA	MNPT
GF-MP-014	PI	MIX	105	PI-MIX-105	9517-PID-105	23	Blender Propane Vapor Inlet Pressure Indicator #1	US Gauge	1981 # 150027DM	0.5	NA	MNPT
GF-MP-014	PI	MIX	106	PI-MIX-106	9517-PID-105	43	Mixed Gas Pressure Indicator	US Gauge	1981 # 150027DM	0.5	NA	MNPT
GF-MP-014	PI	MIX	107	PI-MIX-107	9517-PID-105	71	Propane-Air to QT Pressure Indicator	Trerice	D83SS2502LA110	0.25	NA	MNPT
GF-MP-014	PI	MIX	108	PI-MIX-108	9517-PID-105	46	Mixed Gas Pressure Indicator #2	US Gauge	1981 # 150027DM	0.5	NA	MNPT
GF-MP-014	PI	NG	101	PI-NG-101	9517-PID-101	34	Natural Gas Pad Pressure Indicator	US Gauge	1981 # 150027DM	0.5	NA	MNPT
GF-MP-014	PI	NG	102	PI-NG-102	9517-PID-101	65	Natural Gas Pad Pressure Indicator	US Gauge	1981 # 150027DM	0.5	NA	MNPT
GF-MP-014	PI	QT	101	PI-QT-101	9517-PID-105	87	Pressure Indicator to S.G. Transducer	Trerice	760B2502LT660	0.25	NA	MNPT
GF-MP-014	PI	TANK1	101	PI-TANK1-101	9517-PID-101	46	Pressure Indicator for Propane Storage Tank No. 1	Trerice	450SS4502LA140	0.25	NA	MNPT
GF-MP-014	PI	TANK2	101	PI-TANK2-101	9517-PID-101	42	Pressure Indicator for Propane Storage Tank No. 2	Trerice	450SS4502LA140	0.25	NA	MNPT
GF-MP-006	PRV	T1	1	PRV-T1-1	9517-PID-101	72	Tank 001 Primary Relief Valve #1					
GF-MP-006	PRV	T1	2	PRV-T1-2	9517-PID-101	73	Tank 001 Primary Relief Valve #2					
GF-MP-006	PRV	T1	3	PRV-T1-3	9517-PID-101	74	Tank 001 Primary Relief Valve #3					
GF-MP-006	PRV	T1	4	PRV-T1-4	9517-PID-101	75	Tank 001 Primary Relief Valve #4					
GF-MP-006	PRV	T2	1	PRV-T2-1	9517-PID-101	76	Tank 002 Primary Relief Valve #1					
GF-MP-006	PRV	T2	2	PRV-T2-2	9517-PID-101	77	Tank 002 Primary Relief Valve #2					
GF-MP-006	PRV	T2	3	PRV-T2-3	9517-PID-101	78	Tank 002 Primary Relief Valve #3					
GF-MP-006	PRV	T2	4	PRV-T2-4	9517-PID-101	79	Tank 002 Primary Relief Valve #4					
GF-MP-048	PSH	MIX	101	PSH-MIX-101	9517-PID-105	41	Mixed Gas High Pressure Switch	Solon	6PSX-1-2	0.5	NA	MNPT
GF-MP-005	PSL	IAS	101	PSL-IAS-101	9517-PID-104	3	Instrument Air Pressure Switch	Solon	2PSW-12	0.25	0.25	FNPT

PROJECT: Berkshire Gas Co.  
 JOB NUMBER: 9517  
 REF. DRAWING: 9517-PID-101

FILE DATE: 5/4/2012  
 REVISION DATE: 9/10/2012  
 PRINT DATE: 1/29/2013 10:55

The information contained in this document and/or electronic file(s) is proprietary and/or confidential property Standby Systems, Inc. and shall not be used, reproduced or disclosed to others without the express written consent of the respective owner(s). If consent for reproduction or disclosure in whole or in part is given, this notice shall be set forth on each document page and/or in each electronic reproduction so authorized.

Entry #	Drawing #	DEVICE TAG NAME			REFERENCE DRAWING No.	FUNCTIONAL DESCRIPTION	CONNECT SIZE IN	CONNECT SIZE OUT	CONNECT TYPE	MANUFACTURER NAME	MODEL / CATALOG NUMBER	CONSTRUCTION NOTES
		DEVICE CODE	EQUIP. CODE	ID CODE								
1	8	FCV	IAS	101	9517-PID-101a	Flow Control Valve for (FCV-TANK1-101)	0.125	0.125	FNPT	Schraeder-Bellows	SPF200B	Flow Control Valve 1/8"
2	12	FCV	IAS	101	9517-PID-101a	Flow Control Valve for (FCV-TANK1-102)	0.125	0.125	FNPT	Schraeder-Bellows	SPF200B	Flow Control Valve 1/8"
3	20	FCV	IAS	101	9517-PID-101a	Flow Control Valve for (FCV-TANK1-103)	0.125	0.125	FNPT	Schraeder-Bellows	SPF200B	Flow Control Valve 1/8"
4	9	FCV	IAS	101	9517-PID-101a	Flow Control Valve for (FCV-TANK2-101)	0.125	0.125	FNPT	Schraeder-Bellows	SPF200B	Flow Control Valve 1/8"
5	13	FCV	IAS	101	9517-PID-101a	Flow Control Valve for (FCV-TANK2-102)	0.125	0.125	FNPT	Schraeder-Bellows	SPF200B	Flow Control Valve 1/8"
6	21	FCV	IAS	101	9517-PID-101a	Flow Control Valve for (FCV-TANK2-103)	0.125	0.125	FNPT	Schraeder-Bellows	SPF200B	Flow Control Valve 1/8"
7	28	FCV	IAS	102	9517-PID-101a	IAS Solenoid Valve for Tank #1	0.25	0.25	FNPT	Parker Skinner	71315SN2MNJ1N0H111C2	3-way, SS body, 24 VDC, Class F, 10W
8	29	FCV	IAS	103	9517-PID-101a	IAS Solenoid Valve for Tank #2	0.25	0.25	FNPT	Parker Skinner	71315SN2MNJ1N0H111C2	3-way, SS body, 24 VDC, Class F, 10W
9	32	FCV	IAS	104	9517-PID-101a	IAS Solenoid Valve for (FCV-NG-103)	0.25	0.25	FNPT	Parker Skinner	71315SN2MNJ1N0H111C2	3-way, SS body, 24 VDC, Class F, 10W
10	33	FCV	IAS	105	9517-PID-101b	Flow Control Valve for (FCV-NG-103)	0.125	0.125	FNPT	Schraeder-Bellows	SPF200B	Flow Control Valve 1/8"
11	10	HV	IAS	101	9517-PID-101a	Vented Ball Valve for (FCV-TANK1-101)	0.25	0.25	FNPT	Apollo	7K-101-27	1/4" Brass Ball Valve w/ Drain, SS Latch Lock Lever and Nut
12	52	HV	IAS	101	9517-PID-101b	Vented Ball Valve for (FCV-TANK1-102)	0.25	0.25	FNPT	Apollo	7K-101-27	1/4" Brass Ball Valve w/ Drain, SS Latch Lock Lever and Nut
13	24	HV	IAS	101	9517-PID-101a	Vented Ball Valve for (FCV-TANK1-103)	0.25	0.25	FNPT	Apollo	7K-101-27	1/4" Brass Ball Valve w/ Drain, SS Latch Lock Lever and Nut
14	11	HV	IAS	101	9517-PID-101a	Vented Ball Valve for (FCV-TANK2-101)	0.25	0.25	FNPT	Apollo	7K-101-27	1/4" Brass Ball Valve w/ Drain, SS Latch Lock Lever and Nut
15	19	HV	IAS	101	9517-PID-101a	Vented Ball Valve for (FCV-TANK2-102)	0.25	0.25	FNPT	Apollo	7K-101-27	1/4" Brass Ball Valve w/ Drain, SS Latch Lock Lever and Nut
16	25	HV	IAS	101	9517-PID-101a	Vented Ball Valve for (FCV-TANK2-103)	0.25	0.25	FNPT	Apollo	7K-101-27	1/4" Brass Ball Valve w/ Drain, SS Latch Lock Lever and Nut
17	64	HV	IAS	102	9517-PID-101b	Vented Ball Valve for (FCV-NG-103)	0.25	0.25	FNPT	RUB	S93B41	1/4" Brass Ball Valve, Vented
18	35	FCV	NG	101	9517-PID-101b	Natural Gas Pad Check Valve #1	2	2	ANSI 150#	Wheatley	510-025027-121	Carbon Steel Flanged End Check Valve, Raised Face
19	69	FCV	NG	102	9517-PID-101b	Natural Gas Pad Check Valve #2	2	2	ANSI 150#	Wheatley	510-025027-121	Carbon Steel Flanged End Check Valve, Raised Face
20	38	FCV	NG	103	9517-PID-101b	Natural Gas Pad Actuated Ball Valve	2	2	ANSI 150#	Kuka/Triac	CBA15BGLN/2R200SR-LT	Full Port, Fire Rated, Carbon Steel Body, Stainless Steel Trim w/ Triac Actuator
21	36	HV	NG	101	9517-PID-101b	Natural Gas Pad Inlet Ball Valve	2	2	ANSI 150#	Kuka	CBA15BGLN	Full Port, Fire Rated, Carbon Steel Body, Stainless Steel Trim
22	66	HV	NG	102	9517-PID-101b	Natural Gas Pad Gauge Isolation Valve # 1	0.5	0.5	MNPT x FNPT	Dragon	10M517G	CS Body, Grafoil Packing - 6000 psig Max
23	67	HV	NG	103	9517-PID-101b	Natural Gas Pad Gauge Isolation Valve # 2	0.5	0.5	MNPT x FNPT	Dragon	10M517G	CS Body, Grafoil Packing - 6000 psig Max
24	37	PCV	NG	101	9517-PID-101b	Natural Gas Pad Pressure Regulator	1	1	FNPT	Fisher	627	Steel body, 1/4" orifice, 70-150 psig Spring Range
25	34	PI	NG	101	9517-PID-101b	Natural Gas Pad Pressure Indicator	0.5	NA	MNPT	US Gauge	1981 # 150027DM	4.5" Dial, 1/2" Lower Mount, 0-200 Psig Range
26	65	PI	NG	102	9517-PID-101b	Natural Gas Pad Pressure Indicator	0.5	NA	MNPT	US Gauge	1981 # 150027DM	4.5" Dial, 1/2" Lower Mount, 0-200 Psig Range
27	68	HV	TA	105	9517-PID-101b	Propane Vapor Line 3-Way Ball Valve for Hydrostatic Relief Valves	0.5	0.5	FNPT	Apollo	76-603	3-Way, SS Body, and Trim
28	56	HV	TA	106	9517-PID-101b	Propane Vapor Line 3-Way Ball Valve for Hydrostatic Relief Valves	0.5	0.5	FNPT	Apollo	76-603	3-Way, SS Body, and Trim
29	23	HV	TA	107	9517-PID-101a	Propane Liquid Line 3-Way Ball Valve for Hydrostatic Relief Valves	0.5	0.5	FNPT	Apollo	76-603	3-Way, SS Body, and Trim
30	71	PSV	TA	101	9517-PID-101b	Natural Gas Hydrostatic Relief Valve # 1	0.5	0.5	MNPT	Rego	3129U w/ 3129-10	450 Psig Hydrostatic Relief Valve w 3129-10 Pipe Away
31	70	PSV	TA	102	9517-PID-101b	Natural Gas Hydrostatic Relief Valve # 2	0.5	0.5	MNPT	Rego	3129U w/ 3129-10	450 Psig Hydrostatic Relief Valve w 3129-10 Pipe Away
32	27	PSV	TA	103	9517-PID-101a	Propane Vapor Line Hydrostatic Relief Valve # 1	0.5	0.5	MNPT	Rego	3129U w/ 3129-10	450 Psig Hydrostatic Relief Valve w 3129-10 Pipe Away
33	55	PSV	TA	104	9517-PID-101b	Propane Vapor Line Hydrostatic Relief Valve # 2	0.5	0.5	MNPT	Rego	3129U w/ 3129-10	450 Psig Hydrostatic Relief Valve w 3129-10 Pipe Away
34	54	PSV	TA	105	9517-PID-101b	Propane Liquid Line Hydrostatic Relief Valve # 1	0.5	0.5	MNPT	Rego	3129U w/ 3129-10	450 Psig Hydrostatic Relief Valve w 3129-10 Pipe Away
35	53	PSV	TA	106	9517-PID-101b	Propane Liquid Line Hydrostatic Relief Valve # 2	0.5	0.5	MNPT	Rego	3129U w/ 3129-10	450 Psig Hydrostatic Relief Valve w 3129-10 Pipe Away
36	14	FCV	TANK1	101	9517-PID-101a	Actuated Internal Valve - Propane Liquid Out Line, Propane Storage Tank No. 1	3	3	MNPT/FNPT	Rego	A3213R300 w/ A3213PA	~300 GPM Liquid Propane Close Rate, NPT Internal Valve w/ Actuator
37	15	FCV	TANK1	102	9517-PID-101a	Actuated Internal Valve - Propane Liquid Fill Line, Propane Storage Tank No. 1	2	2	MNPT/FNPT	Rego	A3212R250 w/A3213PA	~250 GPM Liquid Propane Close Rate, NPT Internal Valve w/ Actuator
38	16	FCV	TANK1	103	9517-PID-101a	Actuated Internal Valve - Propane Vapor Line, Propane Storage Tank No. 1	2	2	MNPT/FNPT	Rego	A3212R250 w/A3213PA	~250 GPM Liquid Propane Close Rate, NPT Internal Valve w/ Actuator
39	61	HV	TANK1	101	9517-PID-101b	Isolation Ball Valve - Liquid Out Line, Propane Storage Tank No. 1	3	3	ANSI 300#	Kuka	CBA30BG	Full Port Fire Rated Carbon Steel Body, Stainless Steel Trim
40	62	HV	TANK1	102	9517-PID-101b	Isolation Ball Valve - Liquid Fill Line Propane, Storage Tank No. 1	2	2	ANSI 300#	Kuka	CBA30BG	Full Port Fire Rated Carbon Steel Body, Stainless Steel Trim
41	58	HV	TANK1	103	9517-PID-101b	Isolation Ball Valve - Natural Gas Line, Propane Storage Tank No. 1	2	2	ANSI 300#	Kuka	CBA30BG	Full Port Fire Rated Carbon Steel Body, Stainless Steel Trim
42	59	HV	TANK1	104	9517-PID-101b	Isolation Ball Valve - Propane Vapor Line Propane Storage Tank No. 1	2	2	ANSI 300#	Kuka	CBA30BG	Full Port Fire Rated Carbon Steel Body, Stainless Steel Trim
43	41	HV	TANK1	105	9517-PID-101b	Instrument Isolation Valve for LI TANK1 102, Propane Storage Tank No. 1	0.25	0.25	MNPT x FNPT	Anderson Greenwood	H5VIS22A	1/4" SS Angle Needle Valve, w/ T Handle
44	48	HV	TANK1	106	9517-PID-101b	Instrument Isolation Valve for PI & PT TANK1 101, Propane Storage Tank No. 1	0.25	0.25	MNPT x FNPT	Anderson Greenwood	H5VIS22A	1/4" SS Angle Needle Valve, w/ T Handle
45	49	LI	TANK1	101	9517-PID-101b	Level Indicator for Propane Storage Tank No. 1	2.5	NA	MNPT	Taylor	ME3862B / 5331 Adapter	11" Diameter Tank Master LP End Mount, 8" Dial
46	43	LI	TANK1	102	9517-PID-101b	85% Spilt Valve to be Installed on (HV-TANK1-105)	0.25	NA	MNPT	Marshall Excelsior	MEJ402S	85% Bleeder to be installed on H5VIS22A
47	40	LT	TANK1	101	9517-PID-101b	Liquid Level Transmitter for Propane Storage Tank No. 1	0.75	NA	MNPT	MTS	MRA2B1B11A1U110.00S	110" Order Length, 3/4" MNPT, Calibrated 4" to 108.25", -30 to 150 F
48	46	PI	TANK1	101	9517-PID-101b	Pressure Indicator for Propane Storage Tank No. 1	0.25	NA	MNPT	Tertrac	450SS4502LA140	4.5" Dial, 1/4" LM Connection, 0-300 Psig Range, SS
49	44	PT	TANK1	101	9517-PID-101b	Pressure Indicating Transmitter for Propane Storage Tank No. 1	0.5	NA	MNPT	Wika	E-10 # 4365182	0-300 Psig Scale, Explosion Proof, Wire End
50	50	TI	TANK1	101	9517-PID-101b	Temperature Indicator for Tank No. 1	0.5	NA	MNPT	Tei-Tru	GT-300R	-40 to 160 Deg F, 6" Stem
51	39	TT	TANK1	101	9517-PID-101b	Temperature Transmitter for Tank No. 1	NA	NA	NA	MTS	Part of LT-T1-101	Internal Temp Transmitter (see LT-T1-101)
52	3	TW	TANK1	101	9517-PID-101a	Thermowell Included (LT-TANK1-101)	0.75	0.75	MNPT x FNPT	MTS	Part of LT-T1-101	Thermowell (see LT-T1-101)
53	17	FCV	TANK2	101	9517-PID-101a	Actuated Internal Valve - Propane Liquid Out Line, Propane Storage Tank No. 2	3	3	MNPT/FNPT	Rego	A3213R300 w/ A3213PA	~300 GPM Liquid Propane Close Rate, NPT Internal Valve w/ Actuator
54	18	FCV	TANK2	102	9517-PID-101a	Actuated Internal Valve - Propane Liquid Fill Line, Propane Storage Tank No. 2	2	2	MNPT/FNPT	Rego	A3212R250 w/A3213PA	~250 GPM Liquid Propane Close Rate, NPT Internal Valve w/ Actuator
55	51	FCV	TANK2	103	9517-PID-101b	Actuated Internal Valve - Propane Vapor Line, Propane Storage Tank No. 2	2	2	MNPT/FNPT	Rego	A3212R250 w/A3213PA	~250 GPM Liquid Propane Close Rate, NPT Internal Valve w/ Actuator
56	57	HV	TANK2	101	9517-PID-101b	Isolation Ball Valve - Liquid Out Line, Propane Storage Tank No. 2	3	3	ANSI 300#	Kuka	CBA30BG	Full Port Fire Rated Carbon Steel Body, Stainless Steel Trim
57	63	HV	TANK2	102	9517-PID-101b	Isolation Ball Valve - Liquid Fill Line Propane, Storage Tank No. 2	2	2	ANSI 300#	Kuka	CBA30BG	Full Port Fire Rated Carbon Steel Body, Stainless Steel Trim
58	60	HV	TANK2	103	9517-PID-101b	Isolation Ball Valve - Natural Gas Line, Propane Storage Tank No. 2	2	2	ANSI 300#	Kuka	CBA30BG	Full Port Fire Rated Carbon Steel Body, Stainless Steel Trim
59	30	HV	TANK2	104	9517-PID-101a	Isolation Ball Valve - Propane Vapor Line Propane Storage Tank No. 2	2	2	ANSI 300#	Kuka	CBA30BG	Full Port Fire Rated Carbon Steel Body, Stainless Steel Trim
60	5	HV	TANK2	105	9517-PID-101a	Combo Valve for Propane Storage Tank No. 2	0.75	0.25	MNPT x FNPT	Marshall Excelsior	MEJ415	Combo Valve for 85% Bleed Valve, Pressure Gauge
61	47	LI	TANK2	101	9517-PID-101b	Level Indicator for Propane Storage Tank No. 2	2.5	NA	MNPT	Taylor	ME3862B / 5331 Adapter	11" Diameter Tank Master LP End Mount, 8" Dial
62	6	LI	TANK2	102	9517-PID-101a	85% Spilt Valve to be Installed on (HV-TANK2-105)	0.25	NA	MNPT	Marshall Excelsior	MEJ402S	85% Bleeder to be installed on MEJ415
63	2	LT	TANK2	101	9517-PID-101a	Liquid Level Transmitter for Propane Storage Tank No. 2	0.75	NA	MNPT	MTS	MRA2B1B11A1U110.00S	110" Order Length, 3/4" MNPT, Calibrated 4" to 108.25", -30 to 150 F

64	42	PI	TANK2	101	9517-PID-101b	Pressure Indicator for Propane Storage Tank No. 2	0.25	NA	MNPT	Trerice	450SS4502LA140	4.5" Dial, 1/4" LM Connection, 0-300 Psig Range, SS
65	45	PT	TANK2	101	9517-PID-101b	Pressure Indicating Transmitter for Propane Storage Tank No.2	0.5	NA	MNPT	Wika	E-10 # 4365182	0-300 Psig Scale, Explosion Proof, Wire End
66	7	TI	TANK2	101	9517-PID-101a	Temperature Indicator for Tank No. 2	0.5	NA	MNPT	Tel-Tru	GT-300R	-40 to 160 Deg F, 6" Stem
67	1	TT	TANK2	101	9517-PID-101a	Temperature Transmitter for Tank No. 2	NA	NA	NA	MTS	Part of LT-T2-101	Internal Temp Transmitter (see LT-TI-101)
68	4	TW	TANK2	101	9517-PID-101a	Thermowell Included (LT-TANK2-101)	0.75	0.75	MNPT x FNPT	MTS	Part of LT-T2-101	Thermowell (see LT-TI-101)
69	26	FCV	VAP	102	9517-PID-101a	Propane Vapor to Blender Discharge Check Valve	1	1	FNPT	Wheatley	822-013072-131	CS Body, SS Clapper, 720# Working Pressure
70	31	HV	VAP	103	9517-PID-101a	Propane Vapor to Blender Discharge Isolation Ball Valve	1	1	FNPT	Jamesbury	9FB3600XT	Stainless Steel Body and Trim, Fire Safe
71	22	PSV	VAP	101	9517-PID-101a	Propane Vapor to Blender Hydrostatic Relief Valve	0.5	0.5	MNPT	Rego	3129U w/ 3129-10	450 Psig Hydrostatic Relief Valve w 3129-10 Pipe Away
72		PRV	T1	1	9517-PID-101a	Tank 001 Primary Relief Valve #1						
73		PRV	T1	2	9517-PID-101a	Tank 001 Primary Relief Valve #2						
74		PRV	T1	3	9517-PID-101a	Tank 001 Primary Relief Valve #3						
75		PRV	T1	4	9517-PID-101a	Tank 001 Primary Relief Valve #4						
76		PRV	T2	1	9517-PID-101a	Tank 002 Primary Relief Valve #1						
77		PRV	T2	2	9517-PID-101a	Tank 002 Primary Relief Valve #2						
78		PRV	T2	3	9517-PID-101a	Tank 002 Primary Relief Valve #3						
79		PRV	T2	4	9517-PID-101a	Tank 002 Primary Relief Valve #4						

PROJECT: Berkshire Gas Co.  
 JOB NUMBER: 12023  
 REF. DRAWING: 12023-PID-103-R3

FILE DATE: 5/7/2012  
 REVISION DATE: 7/13/18  
 PRINT DATE: 5/31/19

The information contained in this document and/or electronic file(s) is proprietary and/or confidential property Standby Systems, Inc. and shall not be used, reproduced or disclosed to others without the express written consent of the respective owner(s). If consent for reproduction or disclosure in whole or in part is given, this notice shall be set forth on each document page and/or in each electronic reproduction so authorized.

Drawin g #	DEVICE TAG NAME			REFERENCE DRAWING No.	FUNCTIONAL DESCRIPTION	CONNECT SIZE IN	CONNECT SIZE OUT	CONNECT TYPE	MANUFACTURER NAME	MODEL / CATALOG NUMBER	CONSTRUCTION NOTES
	DEVICE CODE	EQUIP CODE	ID CODE								
1	HV	AIR	105	12023-PID-102-R03	Process Air Compressor Discharge Isolation Valve	3	3	ANSI 150#	Kuka	CBA15BGLN	Carbon Steel Body, SS Trim, Fire Safe, Full Port
2	HV	AIR	104	12023-PID-102-R03	Process Air Compressor Discharge Isolation Valve	3	3	ANSI 150#	Kuka	CBA15BGLN	Carbon Steel Body, SS Trim, Fire Safe, Full Port
3	PE	AIR	101	12023-PID-102-R03	Process Air Compressor No. 2	NA	3	FNPT	Atlas Copco	GA110-6.9-60	Oil Injected 150 HP Rotary Screw, 747 SCFM @ 90 psig Capacity
4	PI	AIR	101	12023-PID-102-R03	Process Air Tank Pressure Indicator	0.5	0.5	MNPT	US Gauge	1981 # 150027DM	4.5" Dial, 1/2" Lower Mount, Dry, 0-200 Psig Range
5	HV	AIR	103	12023-PID-102-R03	Process Air Tank Instrument Isolation Valve	0.5	0.5	MXFNPT	Dragon	10M517G	CS Bar Stock Body - 6000 psig Max
6	PSV	AIR	101	12023-PID-102-R03	Process Air Tank Relief Valve	1"	1/2"	MNPT x FNPT	Kunkle	6283FEV01	978 SCFM Capacity, up to 406 Deg F, 150 Psig Setting
7	HV	AIR	102	12023-PID-102-R03	Process Air Tank Drain Valve	1	1	FNPT	RUB	S92EB8	1" Non-Vented Brass Ball Valve
8	PE	AIR	102	12023-PID-102-R03	Process Air Compressor	3	3	ANSI 150#	Sylvin Tank	TBD	620 Gallon, 3" 150# Flange Connection, ASME
9	TT	AIR	102	12023-PID-102-R03	Process Air Tank No.2	1	2	FNPT	Algas-SDI	Q1650V	1650 GPH Liquid Propane Vaporizer
10	HV	AIR	101	12023-PID-102-R03	Process Air Compressor Discharge Isolation Valve	3	3	ANSI 150#	Kuka	CBA15BGLN	Carbon Steel Body, SS Trim, Fire Safe, Full Port
11	PE	AIR	101	12023-PID-102-R03	Process Air Compressor No. 1	NA	3	FNPT	Atlas Copco	GA110-6.9-60	Oil Injected 150 HP Rotary Screw, 747 SCFM @ 90 psig Capacity
12	TT	AIR	101	12023-PID-102-R03	Process Air Tank No.1					GA110-6.9-60	480 VAC 150 HP
13	PA	VAP	101	12023-PID-102-R03	Vaporizer Relief Stack Cap	2	NA	NA	Annes Weather Cap	WC 5	Weather Cap
14	PA	VAP	102	12023-PID-102-R03	Vaporizer Relief Valve Pipe Away Adapter	1.25	2	NPT	Rego	3135-10	Relief Valve Pipe Away Adapter
15	PT	VAP	101	12023-PID-102-R03	Vaporizer Outlet Pressure Transmitter	0.5	NA	FNPT	Wika	E-10 # 4365182	0-300 Psig Scale, Explosion Proof
16	HV	VAP	102	12023-PID-102-R03	Instrument Isolation Ball Valve	0.5	0.5	MNPT x FNPT	Dragon	10M517G	CS Bar Stock Body - 6000 psig Max
17	RTD	VAP	101	12023-PID-102-R03	Vaporizer Outlet Resistive Temperature Device	0.5	NA	FNPT	Pyromation	R1T185L483-S4C0409-SL-8HN71	3 Wire, Element, 100 Ohm Platinum, XP Connection Head
18	TW	VAP	101	12023-PID-102-R03	Vaporizer Outlet Thermowell for Temperature Transmitter	0.5	NA	FNPT	Pyromation	Part of RTD- VAP-101	1/2" Connection, 2.5" Insertion Length
19	FCV	VAP	101	12023-PID-102-R03	Vaporizer Discharge Actuated Ball Valve	3	3	ANSI 300#	Kuka/Triac	CBA30BGLN/2R300SR-LT	Full Port, Fire Rated, Carbon Steel Body, Stainless Steel Trim w/ Triac Actuator
20	FCV	IAS	122	12023-PID-102-R03	IAS Solenoid Valve for (FCV-VAP-101)	0.25	0.25	FNPT	Parker Skinner	71315SN2MNU1N0H11C2	3-way, SS body, 24 VDC, Class F, 10W
21	FCV	IAS	123	12023-PID-102-R03	IAS Flow Control Valve for (FCV-VAP-101)	0.125	0.125	FNPT	Schraeder-Bellows	SPF200B	Flow Control Valve 1/8 "
22	HV	IAS	118	12023-PID-102-R03	IAS Vented Ball Valve for (FCV-VAP-101)	0.25	0.25	FNPT	RUB	S93B41	1/4" Brass Ball Valve, Vented
23	PE	VAP	101	12023-PID-102-R03	Q1650V Vertical Waterbath Vaporizer 1	1	2	FNPT	Algas-SDI	Q1650V	1650 GPH Liquid Propane Vaporizer
24	HV	VAP	103	12023-PID-102-R03	Vaporizer 1 Inlet Isolation Ball Valve	2	2	ANSI 300#	Titan	YS-62-CS	Carbon Steel Body, SS 40 Mesh Strainer
25	ST	VAP	101	12023-PID-102-R03	Vaporizer Inlet Strainer	2	2	ANSI 300#	Titan	YS-62-CS	Carbon Steel Body, SS 40 Mesh Strainer
26	HV	VAP	101	12023-PID-102-R03	Vaporizer Inlet Isolation Ball Valve	2	2	ANSI 300#	Kuka	CBA30BGLN	Full Port, Fire Rated, Carbon Steel Body, Stainless Steel Trim
27	FCV	IAS	106	12023-PID-102-R03	IAS Solenoid Valve for (FCV-VAP-102)	0.25	0.25	FNPT	Parker Skinner	71315SN2MNU1N0H11C2	3-way, SS body, 24 VDC, Class F, 10W
28	FCV	IAS	107	12023-PID-102-R03	IAS Flow Control Valve for (FCV-VAP-102)	0.125	0.125	FNPT	Schraeder-Bellows	SPF200B	Flow Control Valve 1/8 "
29	HV	IAS	104	12023-PID-102-R03	IAS Vented Ball Valve for (FCV-VAP-102)	0.25	0.25	FNPT	RUB	S93B41	1/4" Brass Ball Valve, Vented
30	PA	VAP	103	12023-PID-102-R03	Vaporizer Relief Stack Cap	2	NA	NA	Annes Weather Cap	WC 5	Weather Cap
31	PA	VAP	104	12023-PID-102-R03	Vaporizer Relief Valve Pipe Away Adapter	1.25	2	NPT	Rego	3135-10	Relief Valve Pipe Away Adapter
32	PT	VAP	102	12023-PID-102-R03	Vaporizer Outlet Pressure Transmitter	0.5	NA	FNPT	Wika	E-10 # 4365182	0-300 Psig Scale, Explosion Proof
33	HV	VAP	105	12023-PID-102-R03	Instrument Isolation Ball Valve	0.5	0.5	MNPT x FNPT	Dragon	10M517G	CS Bar Stock Body - 6000 psig Max
34	RTD	VAP	102	12023-PID-102-R03	Vaporizer Outlet Resistive Temperature Device	0.5	NA	FNPT	Pyromation	R1T185L483-S4C0409-SL-8HN71	3 Wire, Element, 100 Ohm Platinum, XP Connection Head
35	TW	VAP	102	12023-PID-102-R03	Vaporizer Outlet Thermowell for Temperature Transmitter	0.5	NA	FNPT	Pyromation	Part of RTD- VAP-101	1/2" Connection, 2.5" Insertion Length
36	FCV	VAP	102	12023-PID-102-R03	Vaporizer Discharge Actuated Ball Valve	3	3	ANSI 300#	Kuka/Triac	CBA30BGLN/2R300SR-LT	Full Port, Fire Rated, Carbon Steel Body, Stainless Steel Trim w/ Triac Actuator
37	PE	VAP	102	12023-PID-102-R03	Q1650V Vertical Waterbath Vaporizer 2	1	2	FNPT	Algas-SDI	Q1650V	1650 GPH Liquid Propane Vaporizer
38	HV	VAP	104	12023-PID-102-R03	Vaporizer 2 Inlet Isolation Ball Valve	2	2	ANSI 300#	Kuka	CBA30BGLN	Full Port, Fire Rated, Carbon Steel Body, Stainless Steel Trim
39	PSV	VAP	101	12023-PID-102-R03	Vaporizer Inlet Pressure Relief Valve	1	2	FNPT	Algas-SDI	Q1650V	1650 GPH Liquid Propane Vaporizer

PROJECT: Berkshire Gas Co.  
 JOB NUMBER: 9517  
 REF. DRAWING: 9517-PID-103

FILE DATE: 5/7/2012  
 REVISION DATE: 7/23/2012  
 PRINT DATE: 1/29/2013 10:56

The information contained in this document and/or electronic file(s) is proprietary and/or confidential property Standby Systems, Inc. and shall not be used, reproduced or disclosed to others without the express written consent of the respective owner(s). If consent for reproduction or disclosure in whole or in part is given, this notice shall be set forth on each document page and/or in each electronic reproduction so authorized.

Drawing #	DEVICE TAG NAME			REFERENCE DRAWING No.	FUNCTIONAL DESCRIPTION	CONNECT SIZE IN	CONNECT SIZE OUT	CONNECT TYPE	MANUFACTURER NAME	MODEL / CATALOG NUMBER	CONSTRUCTION NOTES
	DEVICE CODE	EQUIP. CODE	ID CODE								
11	ESV	FTS	101	9517-PID-103a	Emergency Shutoff Valve	1.25	1.25	FNPT	Fisher	N550 w/ P327D	Emergency Shutoff Valve w/ Pneumatic Release
7	FCV	FTS	101	9517-PID-103a	Flow Control Valve (FTS Liquid Line)	2	2	FNPT	Wheatley	822-023072-131	Check Valve - Carbon Steel Body/ SS Clapper
15	FCV	FTS	102	9517-PID-103a	Flow Control Valve (FTS Vapor Line)	1.25	1.25	FNPT	Fisher	F105	Excess Flow Valve
2	HV	FTS	101	9517-PID-103a	Angle Valve (FTS Liquid Line)	2	2	FNPT	Squib-Taylor	AL317P	2" Angle Style Globe Valve
8	HV	FTS	102	9517-PID-103a	Strainer Blow Down Valve	1	1	FNPT	Jamesbury	9FB3600XT	Fire Safe, Stainless Steel Body, Stainless Steel Trim
3	HV	FTS	103	9517-PID-103a	Isolation Ball Valve (FTS Liquid Line)	2	2	FNPT	Jamesbury	9FB3600XT	Fire, Safe, Stainless Steel Body, Stainless Steel Trim
10	HV	FTS	104	9517-PID-103a	Angle Valve (FTS Vapor Line)	1.25	1.25	FNPT	Squibb-Taylor	AL313P	1.25" Angle Style Globe Valve
12	HV	FTS	105	9517-PID-103a	Isolation Ball Valve (FTS Vapor Line)	2	2	FNPT	Jamesbury	9FB3600XT	Fire Safe, Stainless Steel Body, Stainless Steel Trim
14	PE	FTS	101	9517-PID-103a	FTS Bulkhead	1.25	2	FNPT	Standby Systems	SSI Drawing	Engineered Breakaway Risers
1	PE	FTS	102	9517-PID-103a	Liquid Acme Fill Adapter (FTS Liquid Line)	2	3.25	MNPT/ACME	Fisher	ME503-16, ME441F-1	3-1/4" Acme X 2" NPT Acme Adapter/ Cap & Chain
9	PE	FTS	104	9517-PID-103a	Vapor Acme Fill Adapter (FTS Vapor Line)	1.25	2.25	MNPT/ACME	Fisher	ME233, ME431F-1	2-1/4" Acme X 1 1/4" NPT Acme Adapter/ Cap & Chain
4	PSV	FTS	101	9517-PID-103a	Hydrostatic Relief Valve (FTS Liquid Line)	0.25	NA	MNPT	Rego	3125L	400 Psig Hydrostatic Relief Valve
13	PSV	FTS	103	9517-PID-103a	Hydrostatic Relief Valve (FTS Vapor Line)	0.25	NA	MNPT	Rego	3125L	400 Psig Hydrostatic Relief Valve
5	ST	FTS	101	9517-PID-103a	Strainer for (Liquid Fill Line)	2	2	FNPT	Titan	YS-81 CS	Carbon Steel Body w/ 40Mesh Screen
16	HV	IAS	105	9517-PID-103a	Pneumatic Isolation for ESV Valve	0.25	0.25	FNPT	Rub	S93B41	1/4" Brass Ball Valve, Vented
6	PE	FTS	101	9517-PID-103a	FTS Bulkhead	1.25	2	FNPT	Standby Systems	SSI Drawing	Engineered Breakaway Risers



PROJECT: Berkshire Gas Co.  
 JOB NUMBER: 9517  
 REF. DRAWING: 9517-PID-104

FILE DATE: 7/25/2012  
 REVISION DATE: 8/9/2012  
 PRINT DATE: 1/29/2013 10:57

The information contained in this document and/or electronic file(s) is proprietary and/or confidential property Standby Systems, Inc. and shall not be used, reproduced or disclosed to others without the express written consent of the respective owner(s). If consent for reproduction or disclosure in whole or in part is given, this notice shall be set forth on each document page and/or in each electronic reproduction so authorized.

Drawing #	DEVICE TAG NAME			REFERENCE DRAWING No.	FUNCTIONAL DESCRIPTION	CONNECT SIZE IN	CONNECT SIZE OUT	CONNECT TYPE	MANUFACTURER NAME	MODEL / CATALOG NUMBER	CONSTRUCTION NOTES
	DEVICE CODE	EQUIP. CODE	ID CODE								
1	FCV	IAS	119	9517-PID-104a	Instrument Air Main Solenoid Valve	0.5	0.5	FNPT	Parker Skinner	71315SN2MNJ1NOH111C2	3-way, SS body, 24 VDC, Class F, 10W
6	HV	IAS	115	9517-PID-104a	Instrument Air Compressor Discharge Valve	0.5	0.5	FNPT	RUB	S92DB8	Non-Vented 1/2" Brass Ball Valve
7	HV	IAS	116	9517-PID-104a	Instrument Air Isolation Ball Valve	0.5	0.5	FNPT	RUB	S92DB8	Non-Vented 1/2" Brass Ball Valve
8	PCV	IAS	101	9517-PID-104a	Instrument Air Regulator	0.25	0.25	NPT	Control-Air	300-BC	Pressure Regulator, Set 70-80 psig
10	PCV	IAS	102	9517-PID-104a	Instrument Air Regulator	0.25	0.25	NPT	Control-Air	300-BC	Pressure Regulator, Set 30-35 psig
4	PE	IAS	101	9517-PID-104a	Instrument Air Compressor	NA	NA	NA	Atlas Copco	GX2-150	3 HP, 480 VAC 3 phase, 60HZ, capable of 8.5 SCFM, Tank Mounted w/ disconnect switch
5	PE	IAS	102	9517-PID-104a	IAS Dryer and Filter	0.25	0.25	FNPT	Stylair	H12N	10 SCFM Capacity, -40 Deg. Dew Point, Pre and After Filters
2	PI	IAS	101	9517-PID-104a	Instrument Air Pressure Indicator	0.25	NA	FNPT	Trerice	D83SS2502LA110	1/4" LM, 2.5" Dial, SS Case, 0-100 Psig Range
9	PI	IAS	102	9517-PID-104a	Instrument Air Pressure Indicator	0.25	NA	FNPT	Trerice	D83SS2502LA110	1/4" LM, 2.5" Dial, SS Case, 0-100 Psig Range
3	PSL	IAS	101	9517-PID-104a	Instrument Air Pressure Switch	0.25	0.25	FNPT	Solon	2PSW-12	0-100 Psig Range, Enclosure

PROJECT: Berkshire Gas Co.  
 JOB NUMBER: 9517  
 REF. DRAWING: 9517-PID-105

FILE DATE: 5/4/2012  
 REVISION DATE: 9/10/2012  
 PRINT DATE: 1/29/2013 10:55

The information contained in this document and/or electronic file(s) is proprietary and/or confidential property Standby Systems, Inc. and shall not be used, reproduced or disclosed to others without the express written consent of the respective owner(s). If consent for reproduction or disclosure in whole or in part is given, this notice shall be set forth on each document page and/or in each electronic reproduction so authorized.

Drawing #	DEVICE TAG NAME			REFERENCE DRAWING No.	FUNCTIONAL DESCRIPTION	CONNECT SIZE IN	CONNECT SIZE OUT	CONNECT TYPE	MANUFACTURER NAME	MODEL / CATALOG NUMBER	CONSTRUCTION NOTES
	DEVICE CODE	EQUIP. CODE	ID CODE								
7	FCV	IAS	108	9517-PID-105a	Control Air Solenoid Valve for (FCV-MIX-121)	0.25	0.25	FNPT	Parker Skinner	71315SN2MNJ1NOH111C2	3-way, SS body, 24 VDC, Class F, 10W
9	FCV	IAS	109	9517-PID-105a	Control Air Flow Control Valve for (FCV-MIX-101)	0.25	0.25	FNPT	Schrader-Bellows	SPF400B	Flow Control Valve 1/4" FNPT
8	FCV	IAS	110	9517-PID-105a	Control Air Solenoid Valve for (FCV-MIX-101)	0.25	0.25	FNPT	Parker Skinner	71315SN2MNJ1NOH111C2	3-way, SS body, 24 VDC, Class F, 10W
32	FCV	IAS	111	9517-PID-105a	Control Air Solenoid Valve for (FCV-MIX-111)	0.25	0.25	FNPT	Parker Skinner	71315SN2MNJ1NOH111C2	3-way, SS body, 24 VDC, Class F, 10W
50	FCV	IAS	112	9517-PID-105b	Control Air Flow Control Valve for (FCV-MIX-106)	0.25	0.25	FNPT	Schrader-Bellows	SPF400B	Flow Control Valve 1/4" FNPT
49	FCV	IAS	113	9517-PID-105b	Control Air Solenoid Valve for (FCV-MIX-106)	0.25	0.25	FNPT	Parker Skinner	71315SN2MNJ1NOH111C2	3-way, SS body, 24 VDC, Class F, 10W
56	FCV	IAS	114	9517-PID-105b	Control Air Flow Control Valve for (FCV-MIX-108)	0.25	0.25	FNPT	Schrader-Bellows	SPF400B	Flow Control Valve 1/4" FNPT
55	FCV	IAS	115	9517-PID-105b	Control Air Solenoid Valve for (FCV-MIX-108)	0.25	0.25	FNPT	Parker Skinner	71315SN2MNJ1NOH111C2	3-way, SS body, 24 VDC, Class F, 10W
61	FCV	IAS	116	9517-PID-105b	Control Air Flow Control Valve for (FCV-MIX-104)	0.25	0.25	FNPT	Schrader-Bellows	SPF400B	Flow Control Valve 1/4" FNPT
59	FCV	IAS	117	9517-PID-105b	Control Air Solenoid Valve for (FCV-MIX-104)	0.25	0.25	FNPT	Parker Skinner	71315SN2MNJ1NOH111C2	3-way, SS body, 24 VDC, Class F, 10W
5	FCV	IAS	118	9517-PID-105a	Control Air Solenoid Valve for (FCV-MIX-121)	0.25	0.25	FNPT	Parker Skinner	71315SN2MNJ1NOH111C2	3-way, SS body, 24 VDC, Class F, 10W
3	FCV	IAS	120	9517-PID-105a	Control Air Solenoid Valve for (FCV-MIX-123)	0.25	0.25	FNPT	Parker Skinner	71315SN2MNJ1NOH111C2	3-way, SS body, 24 VDC, Class F, 10W
2	FCV	IAS	121	9517-PID-105a	Control Air Flow Control Valve for (FCV-MIX-123)	0.25	0.25	FNPT	Schrader-Bellows	SPF400B	Flow Control Valve 1/4" FNPT
17	FCV	MIX	101	9517-PID-105a	Blender Propane Vapor Inlet Actuated Ball Valve	2	2	ANSI 150#	Kuka/Triac	CBA15BGLN/2R200SR-LT	Full Port, Fire Rated, Carbon Steel Body, Stainless Steel Trim w/ Triac Actuator
20	FCV	MIX	102	9517-PID-105a	Blender Propane Vapor Pressure Control Valve #2	2	2	ANSI 150#	Fisher	V150 - V Ball	V150 W/Type 2052 Size 1 Diaphragm FO Actuator, DVC6200 Positioner, 4200 Position Transmitter
29	FCV	MIX	103	9517-PID-105a	Propane Vapor Check Valve	2	2	ANSI 150#	Wheatley	510-025027-121	Carbon Steel Flanged End Check Valve, Raised Face
76	FCV	MIX	104	9517-PID-105b	Process Air Inlet Actuated Ball Valve #1	2	2	ANSI 150#	Kuka/Triac	CBA15BGLN/2R200SR-LT	Full Port, Fire Rated, Carbon Steel Body, Stainless Steel Trim w/ Triac Actuator
77	FCV	MIX	106	9517-PID-105c	Process Air Inlet Actuated Ball Valve # 2	2	2	ANSI 150#	Kuka/Triac	CBA15BGLN/2R200SR-LT	Full Port, Fire Rated, Carbon Steel Body, Stainless Steel Trim w/ Triac Actuator
93	FCV	MIX	108	9517-PID-105c	Blender Air Supply Vent Valve (Double Block - Normally Open)	1	1	FNPT	Jamesbury/Triac	9FB223600XT/2R200SR-LT	Full Port, Fire Rated, Carbon Steel Body, Stainless Steel Trim w/ Triac Actuator
89	FCV	MIX	110	9517-PID-105c	Process Air Back Check Valve	2	2	ANSI 150#	Wheatley	510-025027-121	Carbon Steel Flanged End Check Valve, Raised Face
78	FCV	MIX	111	9517-PID-105c	Process Air Pressure Control Valve	1.5	1.5	ANSI 150#	Fisher	V150 - V Ball	V150 W/Type 2052 Size 1 Diaphragm FO Actuator, DVC6200 Positioner, 4200 Position Transmitter
45	FCV	MIX	121	9517-PID-105b	Mixed Gas Outlet AuctatedFlow Control Valve	3	3	ANSI 150#	Kuka/Triac	CBA15BGLN/2R300SR-LT	Full Port, Fire Rated, Carbon Steel Body, Stainless Steel Trim w/ Triac Actuator
38	FCV	MIX	122	9517-PID-105b	Propane Vapor from Tanks Header Check Valve	1	1	FNPT	Wheatley	822-013072-131	CS Body, SS Clapper, 720# Working Pressure
31	FCV	MIX	123	9517-PID-105a	Propane Vapor from Tanks Vapor Header Ball Valve	1	1	FNPT	Jamesbury	9FB3600XT	Stainless Steel Body, SS Trim, Fire Safe
66	FCV	QT	101	9517-PID-105b	Solenoid Valve Mixed Gas to S.G. Transducer	0.25	0.25	FNPT	Parker Skinner	71215SN2FU00N0H111C2	2-Way, SS Body, 24VDC, Class F, 10 Watt
21	FT	MIX	101	9517-PID-105a	Blender Propane Vapor Flow Transmitter	2	2	ANSI 150#	Hoffer	HO2X2-15-CB-1MC3PAX-F1SS-X / CAT1-3/O-7-D-X	HO Series Turbine Meter w/ Cat3 Microprocessor Transmitter
79	FT	MIX	102	9517-PID-105c	Blender Process Air Supply Flow Transmitter	2	2	ANSI 150#	Hoffer	HO2X2-15-CB-1MC3PAX-F1SS-X / CAT3-2-1-1-DC-X-2/O-x	HO Series Turbine Meter w/ Cat3 Microprocessor Transmitter
6	HV	IAS	108	9517-PID-105a	Control Air Hand Valve for (FCV-MIX-121)	0.25	0.25	FNPT	Rub	S93B41	1/4", Vented, Brass Ball Valve
10	HV	IAS	109	9517-PID-105a	Control Air Hand Valve for (FCV-MIX-101)	0.25	0.25	FNPT	Rub	S93B41	1/4", Vented, Brass Ball Valve
33	HV	IAS	110	9517-PID-105a	Control Air Hand Valve for (FCV-MIX-111)	0.25	0.25	FNPT	Rub	S93B41	1/4", Vented, Brass Ball Valve
51	HV	IAS	111	9517-PID-105b	Control Air Hand Valve for (FCV-MIX-106)	0.25	0.25	FNPT	Rub	S93B41	1/4", Vented, Brass Ball Valve
54	HV	IAS	112	9517-PID-105b	Control Air Hand Valve for (FCV-MIX-108)	0.25	0.25	FNPT	Rub	S93B41	1/4", Vented, Brass Ball Valve
60	HV	IAS	113	9517-PID-105b	Control Air Hand Valve for (FCV-MIX-104)	0.25	0.25	FNPT	Rub	S93B41	1/4", Vented, Brass Ball Valve
4	HV	IAS	114	9517-PID-105a	Control Air Hand Valve for (FCV-MIX-121)	0.25	0.25	FNPT	Rub	S93B41	1/4", Vented, Brass Ball Valve
1	HV	IAS	117	9517-PID-105a	Control Air Hand Valve for (FCV-MIX-123)	0.25	0.25	FNPT	Rub	S93B41	1/4", Vented, Brass Ball Valve
12	HV	MIX	101	9517-PID-105a	Blender Propane Supply Blowdown Valve	0.5	0.5	FNPT	Jamesbury	9FB3600XT	Stainless Steel Body, SS Trim, Fire Safe
85	HV	MIX	102	9517-PID-105c	Insturment Hand Valve for PT & PI-MIX-103	0.5	0.5	MNPT/FNPT	Dragon	10M517G	CS Body, Grafoil Packing - 6000 psig Max
18	HV	MIX	103	9517-PID-105a	Blender Propane Vapor Insturment Hand Valve for PI-MIX & PT-MIX 102	0.5	0.5	MNPT/FNPT	Dragon	10M517G	CS Body, Grafoil Packing - 6000 psig Max
26	HV	MIX	105	9517-PID-105a	Blender Air Supply Insturment Hand Valve for PI-MIX & PT-MIX-105	0.5	0.5	MNPT/FNPT	Dragon	10M517G	CS Body, Grafoil Packing - 6000 psig Max
92	HV	MIX	106	9517-PID-105c	Blender Strainer Blowdown Valve Process Air (ST-MIX-102)	0.5	0.5	FNPT	Jamesbury	9FB3600XT	Stainless Steel Body, SS Trim, Fire Safe
86	HV	MIX	108	9517-PID-105c	Blender Air Supply Insturment Hand Valve for PT & PI-MIX-104	0.5	0.5	MNPT/FNPT	Dragon	10M517G	CS Body, Grafoil Packing - 6000 psig Max
65	HV	MIX	109	9517-PID-105b	Blender Air Supply Blowdown Valve	0.5	0.5	FNPT	Jamesbury	9FB3600XT	Stainless Steel Body, SS Trim, Fire Safe
44	HV	MIX	110	9517-PID-105b	Mixer Instrument Hand Valve for PT & PI-MIX-106	0.5	0.5	MNPT/FNPT	Dragon	10M517G	CS Body, Grafoil Packing - 6000 psig Max
57	HV	MIX	111	9517-PID-105b	Hand Valve (Mixed Gas to Densitometer)	0.5	0.5	MNPT/FNPT	Dragon	10M517G	Carbon Steel Body, SS Trim, Fire Safe
27	HV	MIX	112	9517-PID-105b	Blender Instrument Hand Valve for PT -MIX-107	0.5	0.5	MNPT/FNPT	Dragon	10M517G	CS Body, Grafoil Packing - 6000 psig Max
48	HV	MIX	119	9517-PID-105a	Blowdown valve for (ST MIX 101)	0.5	0.5	FNPT	Jamesbury	9FB3600XT	Stainless Steel Body, SS Trim, Fire Safe
62	HV	QT	101	9517-PID-105b	Hand Valve Test Port for Air Supply to S.G. Transducer	0.25	0.25	FNPT	Jamesbury	9FB3600XT	Stainless Steel Body, SS Trim, Fire Safe
63	I/Z	MIX	101	9517-PID-105b	Current to Position Transmitter for (FCV-MIX-111)	NA	NA	NA	Fisher	DVC 6200	Current to Position Transmitter for (FCV-MIX-111)
11	I/Z	MIX	103	9517-PID-105a	Current to Position Transmitter for (FCV-MIX-102)	NA	NA	NA	Fisher	DVC 6200	Current to Position Transmitter for (FCV-MIX-102)
19	PCV	MIX	101	9517-PID-105a	Blender Propane Vapor Pressure Control Valve #1	2	2	ANSI 150#	Fisher	1098-EGR	Steel Body w/ CL150RF Flanges, 6353 Pilot w/ 3-40 Psig Spring Range, 125 Psig Main Spring
74	PCV	MIX	103	9517-PID-105b	Propane-Air to QT Pressure Control Valve	0.5	0.5	FNPT	Swagelok	KPR1DRC412A20000	General-Purpose Diaphragm-Sensing, 0-30 psig Range
82	PCV	MIX	109	9517-PID-105c	Air Pressure Control Valve	2	2	ANSI 150#	Fisher	1098-EGR	Steel Body w/ CL150RF Flanges, 6353 Pilot w/ 35-125 Psig Spring Range, size 30 actuator
72	PCV	QT	101	9517-PID-105b	Pressure Regulator Supply Gas to S.G. Transducer	0.25	0.25	FNPT	Fisher	R622-BCF	1/2" NPT, 9" to 13" WC Spring Range
53	PE	MIX	101	9517-PID-105b	Static Mixer	4	4	WELD	Custom	59571	CS w/ Sch. 40, A106 Gr B Pipe Housing, OAL = 16" end to end
58	PE	MIX	102	9517-PID-105b	Inlet Filter for QT	0.125	0.125	FNPT	Balston	9156	SS Housing, Coalescing Filter Element
73	PE	QT	101	9517-PID-105b	Specific Gravity Transducer	0.375	0.25	Swagelok	Yokogawa	GD402G-A-E-E/U & GD40T/EJAF3	Specific Gravity Transducer Sample Panel
22	PI	MIX	102	9517-PID-105a	Blender Propane Vapor Inlet Pressure Indicator #2	0.5	NA	MNPT	US Gauge	1981 # 150027DM	4" Dial, 0-200 Psig Range, 1/2" Lower Mount
75	PI	MIX	103	9517-PID-105b	Blender Air Supply Inlet Pressure Indicator #1	0.5	NA	MNPT	US Gauge	1981 # 150027DM	4" Dial, 0-200 Psig Range, 1/2" Lower Mount
80	PI	MIX	104	9517-PID-105c	Blender Air Supply Inlet Pressure Indicator #2	0.5	NA	MNPT	US Gauge	1981 # 150027DM	4" Dial, 0-200 Psig Range, 1/2" Lower Mount

23	PI	MIX	105	9517-PID-105a	Blender Propane Vapor Inlet Pressure Indicator #1	0.5	NA	MNPT	US Gauge	1981 # 150027DM	4" Dial, 0-200 Psig Range, 1/2" Lower Mount
43	PI	MIX	106	9517-PID-105b	Mixed Gas Pressure Indicator	0.5	NA	MNPT	US Gauge	1981 # 150027DM	4" Dial, 0-200 Psig Range, 1/2" Lower Mount
71	PI	MIX	107	9517-PID-105b	Propane-Air to QT Pressure Indicator	0.25	NA	MNPT	Terlice	D83SS2502LA110	2.5" Dial, 0-100 psig, 1/4" LB Mount
46	PI	MIX	108	9517-PID-105b	Mixed Gas Pressure Indicator #2	0.5	NA	MNPT	US Gauge	1981 # 150027DM	4" Dial, 0-200 Psig Range, 1/2" Lower Mount
87	PI	QT	101	9517-PID-105c	Pressure Indicator to S.G. Transducer	0.25	NA	MNPT	Terlice	760B2502LT660	2.5" Dial, 0-30" WC, 1/4" Lower Mount
41	PSH	MIX	101	9517-PID-105b	Mixed Gas High Pressure Switch	0.5	NA	MNPT	Solon	6PSX-1-2	Class 1 Div 1 0-300 Scale
70	PSV	MIX	101	9517-PID-105b	QT Inlet Relief Valve	0.5	0.5	MXFNPT	Fisher	H120-60	60 PSIG Set Pressure
15	PT	MIX	102	9517-PID-105a	Blender Propane Vapor Pressure Transmitter #2	0.5	NA	MNPT	Wika	E-10 # 50033948	0-200 Psig Range, Wire End
64	PT	MIX	103	9517-PID-105b	Process Air Inlet Pressure Transmitter #1	0.5	NA	MNPT	Wika	E-10 # 50033948	0-200 Psig Range, Wire End
68	PT	MIX	104	9517-PID-105b	Blender Air Supply Inlet Pressure Transmitter #2	0.5	NA	MNPT	Wika	E-10 # 50033948	0-200 Psig Range, Wire End
16	PT	MIX	105	9517-PID-105a	Blender Propane Vapor Pressure Transmitter #1	0.5	NA	MNPT	Wika	E-10 # 50033948	0-200 Psig Range, Wire End
36	PT	MIX	106	9517-PID-105a	Mixed Gas Pressure Transmitter # 1	0.5	NA	MNPT	Wika	E-10 # 50033948	0-200 Psig Range, Wire End
42	PT	MIX	107	9517-PID-105b	Mixed Gas Pressure Transmitter # 2	0.5	NA	MNPT	Wika	E-10 # 50033948	0-200 Psig Range, Wire End
14	RTD	MIX	101	9517-PID-105a	Blender Propane Vapor Resistance Temperature Device	0.5	NA	MNPT	Pyromation	R1T185L483-LS4C2.509-SL-8HN71	3 Wire, Element, 100 Ohm Platinum, XP Connection Head
67	RTD	MIX	102	9517-PID-105b	Air Resistance Temperature Device	0.5	NA	MNPT	Pyromation	R1T185L483-LS4C2.509-SL-8HN71	3 Wire, Element, 100 Ohm Platinum, XP Connection Head
34	RTD	MIX	103	9517-PID-105a	Mixed Gas Vapor Resistance Temperature Device	0.5	NA	MNPT	Pyromation	R1T185L483-S4C0409-SL-8HN71	3 Wire, Element, 100 Ohm Platinum, XP Connection Head
30	ST	MIX	101	9517-PID-105a	Blender Propane vapor Inlet Strainer	2	2	ANSI 150#	Titan	YS-61-CS	Carbon Steel Body, SS 40 Mesh Screen
90	ST	MIX	102	9517-PID-105c	Blender Air Inlet Strainer	2	2	ANSI 150#	Titan	YS-61-CS	Carbon Steel Body, SS 40 Mesh Screen
13	TI	MIX	101	9517-PID-105a	Blender Propane Vapor Temperature Indicator	0.5	NA	MNPT	Dwyer	BTLR325101	Bimetal Thermometer, 3" Dial, 0/200 Deg. F, 2.5" Stem
69	TI	MIX	102	9517-PID-105b	Blender Air Supply Temperature Indicator	0.5	NA	MNPT	Dwyer	BTLS325101	Bimetal Thermometer, 3" Dial, 0/200 Deg. F, 2.5" Stem
35	TI	MIX	103	9517-PID-105a	Mixed Gas Temperature Indicator	0.5	NA	MNPT	ReoTemp	AA-040-1-F43/S4C0409	Bimetal Thermometer, 3" Dial, 0/200 Deg. F, 2.5" Stem
24	TW	MIX	101	9517-PID-105a	Blender Propane Vapor Temp. RTD Thermowell	0.5	0.5	MNPT/FNPT	Pyromation	included with RTD (Part of RTD-MIX-101)	1/2" Process Connection, 1 7/16" Insertion Length
25	TW	MIX	102	9517-PID-105a	Blender Propane Vapor Temp. Indicator Thermowell	0.5	0.5	MNPT/FNPT	Pyromation	LS4C2.509 (Part of TI-MIX-101)	1/2" Process Connection, 1 7/16" Insertion Length
83	TW	MIX	103	9517-PID-105c	Blender Air Supply Temp. RTD Thermowell	0.5	0.5	MNPT/FNPT	Pyromation	included with RTD (Part of RTD-MIX-102)	1/2" Process Connection, 1 7/16" Insertion Length
81	TW	MIX	104	9517-PID-105c	Blender Air Supply Temp. Indicator Thermowell	0.5	0.5	MNPT/FNPT	Pyromation	LS4C2.509 (Part of TI-MIX-102)	1/2" Process Connection, 2.5" Insertion Length
40	TW	MIX	105	9517-PID-105b	Mixed Gas Vapor Temp. RTD Thermowell	0.5	0.5	MNPT/FNPT	Pyromation	included with RTD (Part of RTD-MIX-103)	1/2" Process Connection, 2.5" Insertion Length
39	TW	MIX	106	9517-PID-105b	Mixed Gas Temperature Indicator Thermowell	0.5	0.5	MNPT/FNPT	Pyromation	S4C0409 (Part of TI-MIX-103)	1/2" Process Connection, 2 1/2" Insertion Length
27	ZSC	MIX	101	9517-PID-105a	Propane Inlet Valve Proof Closed Switch for (FCV-MIX-101)	0.5	NA	NA	StoneL	EN33C02RA	Proof Closed Limit Switch (Part of FCV-MIX-101)
88	ZSC	MIX	102	9517-PID-105c	Air Inlet Valve # 1 Proof Closed Switch for (FCV-MIX-104)	0.5	NA	NA	StoneL	EN33C02RA	Proof Closed Limit Switch (Part of FCV-MIX-104)
91	ZSC	MIX	103	9517-PID-105c	Air Inlet Valve # 2 Proof Closed Switch for (FCV-MIX-106)	0.5	NA	NA	StoneL	EN33C02RA	Proof Closed Limit Switch (Part of FCV-MIX-106)
95	ZSC	MIX	104	9517-PID-105c	Air Vent Proof Closed Switch for (FCV-MIX-108)	0.5	NA	NA	StoneL	EN33C02RA	Proof Closed Limit Switch (Part of FCV-MIX-108)
52	ZSC	MIX	105	9517-PID-105b	Proof Closed Switch for (FCV-MIX-121)	0.5	NA	NA	StoneL	EN33C02RA	Proof Closed Limit Switch (Part of FCV-MIX-121)
48	ZSC	MIX	106	9517-PID-105b	Tank Vapor Header Proof Closed Switch for (FCV-MIX-123)	0.5	NA	NA	StoneL	EN33C02RA	Proof Closed Limit Switch (Part of FCV-MIX-108)
94	ZSO	MIX	102	9517-PID-105c	Air Vent Valve Explosion Proof Open Switch for (FCV-MIX-108)	0.5	NA	NA	StoneL	EN33C02RA	Proof Open Limit Switch (Part of FCV-MIX-108)
87	ZSO	MIX	103	9517-PID-105a	Proof Open Switch for (FCV-MIX-123)	0.5	NA	NA	StoneL	EN33C02RA	Proof Open Limit Switch (Part of FCV-MIX-123)
84	QT		101	9517-PID-105c	Not on Device TAG Listing						

PROJECT: Berkshire Gas Co.  
 JOB NUMBER: 9517  
 REF. DRAWING: 9517-PID-102

FILE DATE: 5/7/2012  
 REVISION DATE: 7/5/2012  
 PRINT DATE: 1/29/2013 10:56

The information contained in this document and/or electronic file(s) is proprietary and/or confidential property Standby Systems, Inc. and shall not be used, reproduced or disclosed to others without the express written consent of the respective owner(s). If consent for reproduction or disclosure in whole or in part is given, this notice shall be set forth on each document page and/or in each electronic reproduction so authorized.

Drawing #	DEVICE TAG NAME			REFERENCE DRAWING No.	FUNCTIONAL DESCRIPTION	CONNECT SIZE IN	CONNECT SIZE OUT	CONNECT TYPE	MANUFACTURER NAME	MODEL / CATALOG NUMBER	CONSTRUCTION NOTES
	DEVICE CODE	EQUIP. CODE	ID CODE								
6	HV	AIR	101	9517-PID-102a	Process Air Compressor Discharge Isolation Valve	3	3	ANSI 150#	Kuka	CBA15BGLN	Carbon Steel Body, SS Trim, Fire Safe, Full Port
3	HV	AIR	102	9517-PID-102a	Process Air Tank Drain Valve	1	1	FNPT	RUB	S92EB8	1" Non-Vented Brass Ball Valve
4	HV	AIR	103	9517-PID-102a	Process Air Tank Instrument Isolation Valve	0.5	0.5	MXFNPT	Dragon	10M517G	CS Bar Stock Body - 6000 psig Max
1	PE	AIR	101	9517-PID-102a	Process Air Compressor	NA	3	FNPT	Atlas Copco	GA110-6.9-60	Oil Injected 150 HP Rotary Screw, 747 SCFM @ 90 psig Capacity
7	PE	AIR	102	9517-PID-102a	Process Air Tank	3	3	ANSI 150#	Sylvin Tank	TBD	620 Gallon, 3" 150# Flange Connection, ASME
5	PI	AIR	101	9517-PID-102a	Process Air Tank Pressure Indicator	0.5	0.5	MNPT	US Gauge	1981 # 150027DM	4.5" Dial, 1/2" Lower Mount, Dry, 0-200 Psig Range
2	PSV	AIR	101	9517-PID-102a	Process Air Tank Relief Valve	1"	1/2"	MNPT x FNPT	Kunkle	6283FEV01	978 SCFM Capacity, up to 406 Deg F, 150 Psig Setting
8	FCV	IAS	106	9517-PID-102a	IAS Solenoid Valve for (FCV-VAP-101)	0.25	0.25	FNPT	Parker Skinner	71315SN2MNJ1NOH111C2	3-way, SS body, 24 VDC, Class F, 10W
10	FCV	IAS	107	9517-PID-102a	IAS Flow Control Valve for (FCV-VAP-101)	0.125	0.125	FNPT	Schraeder-Bellows	SPF200B	Flow Control Valve 1/8"
9	HV	IAS	104	9517-PID-102a	IAS Vented Ball Valve for (FCV-VAP-101)	0.25	0.25	FNPT	RUB	S93B41	1/4" Brass Ball Valve, Vented
17	FCV	VAP	101	9517-PID-102a	Vaporizer Discharge Actuated Ball Valve	3	3	ANSI 300#	Kuka/Triac	CBA30BGLN/2R300SR-LT	Full Port, Fire Rated, Carbon Steel Body, Stainless Steel Trim w/ Triac Actuator
20	HV	VAP	101	9517-PID-102a	Vaporizer Inlet Isolation Ball Valve	2	2	ANSI 300#	Kuka	CBA30BGLN	Full Port, Fire Rated, Carbon Steel Body, Stainless Steel Trim
14	HV	VAP	102	9517-PID-102a	Instrument Isolation Ball Valve	0.5	0.5	MNPT x FNPT	Dragon	10M517G	CS Bar Stock Body - 6000 psig Max
11	PA	VAP	101	9517-PID-102a	Vaporizer Relief Stack Cap	2	NA	NA	Antires weatherer Cap	WC 5	Weather Cap
12	PA	VAP	102	9517-PID-102a	Vaporizer Relief Valve Pipe Away Adapter	1.25	2	NPT	Rego	3135-10	Relief Valve Pipe Away Adapter
18	PE	VAP	101	9517-PID-102a	Q1650V Vertical Waterbath Vaporizer	1	2	FNPT	Algas-SDI	Q1650V	1650 GPH Liquid Propane Vaporizer
15	PT	VAP	101	9517-PID-102a	Vaporizer Outlet Pressure Transmitter	0.5	NA	FNPT	Wika	E-10 # 4365182	0-300 Psig Scale, Explosion Proof
13	RTD	VAP	101	9517-PID-102a	Vaporizer Outlet Resistive Temperature Device	0.5	NA	FNPT	Pyromation	R1T185L483-S4C0409-SL-8HN71	3 Wire, Element, 100 Ohm Platinum, XP Connection Head
16	TW	VAP	101	9517-PID-102a	Vaporizer Outlet Thermowell for Temperature Transmitter	0.5	NA	FNPT	Pyromation	Part of RTD- VAP-101	1/2" Connection, 2.5" Insertion Length
19	ST	VAP	101	9517-PID-102a	Vaporizer Inlet Strainer	2	2	ANSI 300#	Titan	YS-62-CS	Carbon Steel Body, SS 40 Mesh Strainer



# iPad ALERT #018

## Add iPage - Browser Icon to iPad Home Screen

To:  
Installers

From:  
Vincent Siciliano,  
Manager, Equipment  
Customer Support/Training



### Installers,

We are pleased to announce the web-based [iPage - Browser](#) is now available.

Drivers can access [iPage - Browser](#) on their iPad or other wireless device, e.g. a smart phone. CLC Managers and Admins can access [iPage - Browser](#) on their PCs.

Once [iPage - Browser](#) is open in Safari on an iPad, add it to your home screen for easy access using the process below.

[iPage - Browser](#) access requires Wi-Fi or use of the Xerox Data plan. Remember – the Xerox iPad Data plan is for Xerox activities ONLY.

**NOTE:** This does not replace the current GoodReader iPage – that version is required to support install sites where no connectivity is available. Installers are still required to regularly sync GoodReader.

If you have questions, please contact your Xerox Trainer.

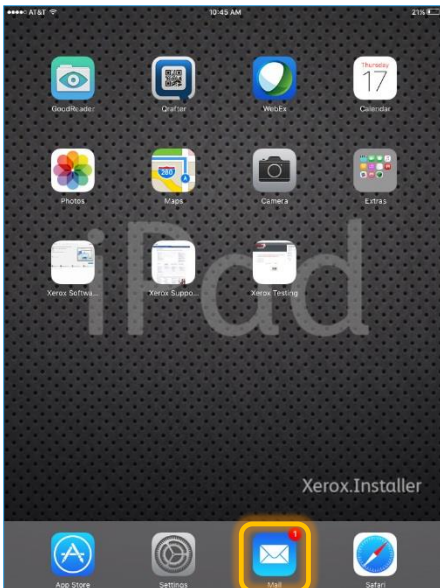

1. Tap **Mail** to open the email app.

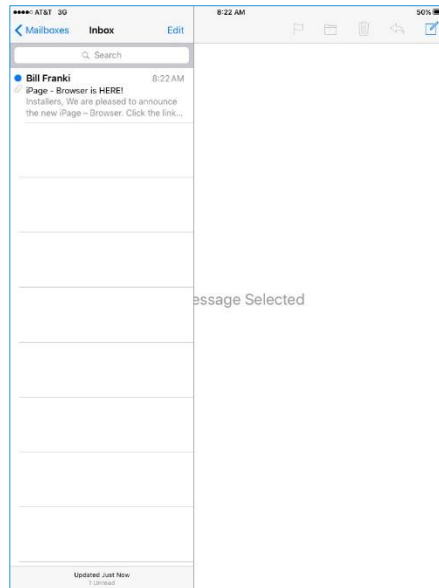

2. Locate the [iPage – Browser](#) announcement email from Bill Franki. Tap to open.

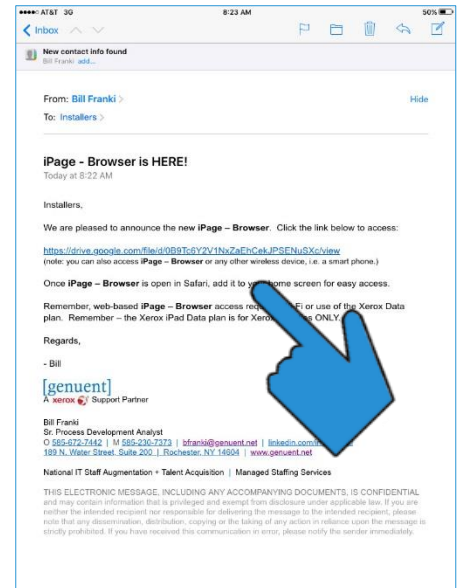

3. Tap the [link](#) in the email to open [iPage – Browser](#) in Safari.



# iPad ALERT #018

## Add iPage - Browser Icon to iPad Home Screen



4. At the iPage Home Screen: Tap the "Share"  icon.



5. The "Share" drop down window opens: Tap **Add to Home Screen**.



6. The "Add to Home" drop down window opens: Tap **Add**.

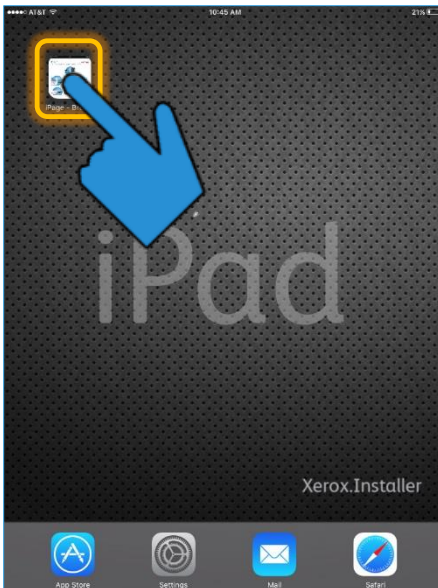

7. Safari closes. The Home Screen and the new icon for [iPage - Browser](#) are displayed. Press and hold the icon until it vibrates.

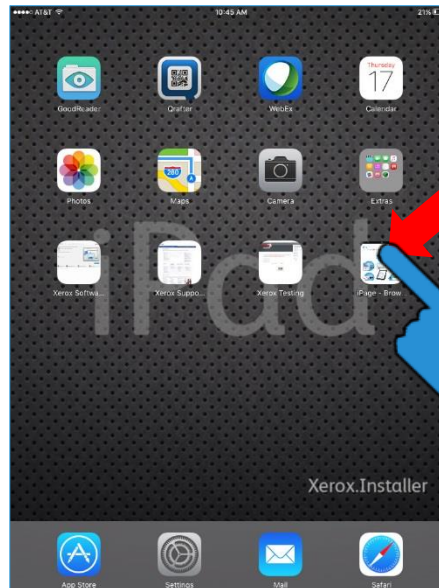

8. Drag the icon to the front Home Screen page. Press the Home Button to complete the move.



That is the end of the procedure.



# Carrier **android** Tab Alert

## Troubleshooting eBOL Connectivity Problems

It has come to our attention some tablet users are experiencing problems when trying to connect to the eBOL Server (see Figures 1 -3 for example error screens). Please try the following actions to address the problem:

- Tap the Xerox Login icon on the Home Screen to open eBOL
- Tap the Menu Button (the three stacked dots) at the upper right hand corner of the screen
- Tap Settings > Clear private data
- Check all boxes except Saved logins, then tap CLEAR DATA
- Use the tablet back button or left arrow at the top of the screen to return to the app
- Power off / power on the tablet
- Tap the Xerox Login icon on the Home Screen to open eBOL, then enter your login and password
- If the normal eBOL Open Manifest screen appears the issue should be resolved.

### If you are unable to access eBOL after clearing data:

- Tap Apps from the Home Screen and tap Chrome
- Enter the URL: <https://carrier.services.xerox.com/EBOL>
- Enter your login and password.
- If the correct eBOL Open Manifest screen appears the issue should be resolved
- Tap the Menu button (3 dots in upper right) and select Add to Home screen. Tap ADD. This will create a new shortcut that will open the Chrome browser instead of Firefox. Use this new icon until further notice.
- If still unable to get into eBOL, tap the Menu button > Settings > Privacy > Clear browsing data > Advanced
- Check Browsing history, Cookies and site data, and Cashed images and files. Tap CLEAR DATA
- Use the tablet back button or left arrow at the top of the screen to return to the app
- Power off / power on the tablet
- Open Chrome and copy/paste this URL: <https://carrier.services.xerox.com/EBOL>, then login if required
- If the correct eBOL Open Manifest screen appears the issue should be resolved
- Tap the Menu button and select Add to Home screen. Tap ADD to create a new shortcut using Chrome instead of Firefox. Use this new icon until further notice.

### If you are still unable to access eBOL:

- Try to login from a computer browser to see if the result is the same
- If that also fails, do a password reset (click Forgot your password).

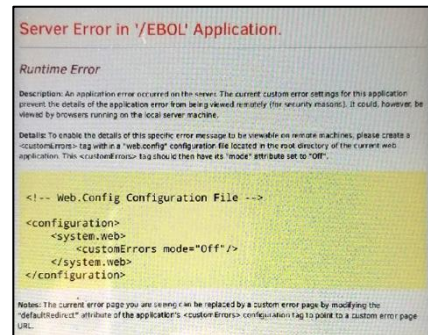

Figure 1: eBOL Server Error

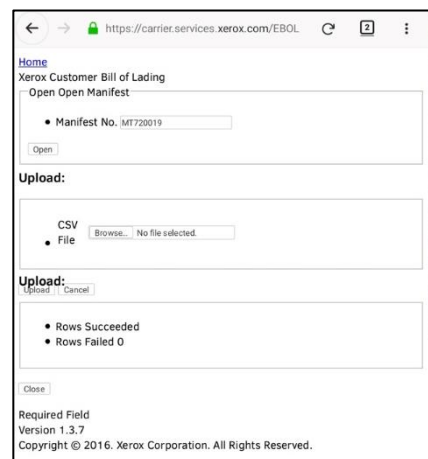

Figure 2: Bad eBOL Open Manifest Screen

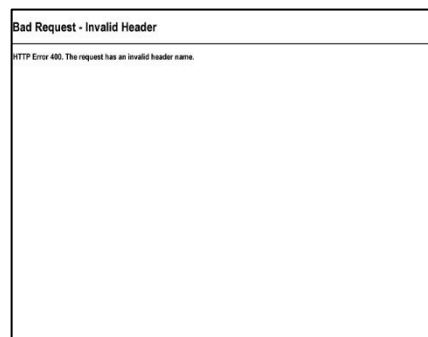

Figure 3: Bad Request - Invalid Header



October 2019 – LAUNCH DRAFT

# Xerox<sup>®</sup> Instant Print Kiosk

## Installation and Relocation Guide



# 1. Ready to Run

1.1



Open Tray 1 and retrieve Multifunction Kiosk Security Kit.

1.2



**Paper MUST be loaded in trays as shown or a machine fault WILL OCCUR**

Set paper guides for paper sizes in trays specifically as shown. Obtain paper stock from onsite contact and load trays.

1.3

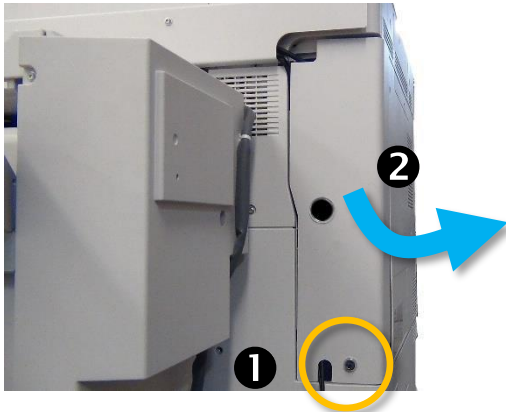

Retrieve a key from Security Kit to 1 unlock right rear corner security door. 2 Swing open security door.

1.4



Obtain network cable from onsite contact and plug into jack on machine.

1.5

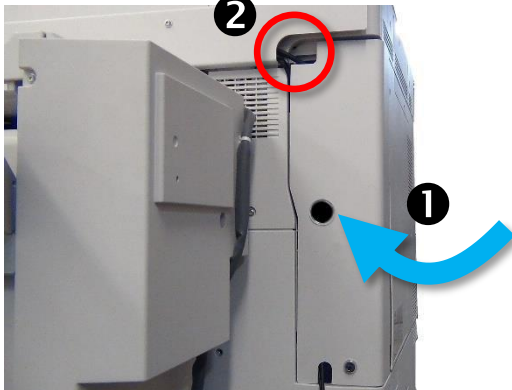

1 Swing security door closed. 2 Ensure no wires are being pinched at top of door.

1.6

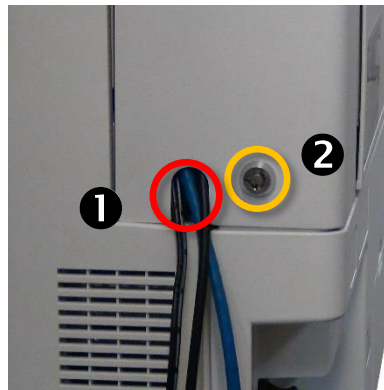

1 Ensure all wires are routed through cutout at bottom of security door. 2 Lock door using security key.



1.7



Return key to Security Kit. Set kit aside to give to onsite contact later in procedure (Step 1.44).

1.9



**NOTE:** if Android Pad UI display goes dark at any point while booting, press Reset Key (shown in Step 1.10) briefly to wake.

1.11

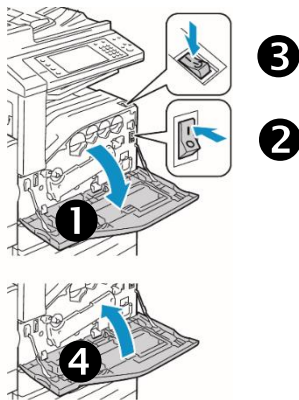

Lower front door ❶ to open position, switch on ❷ primary power switch, switch on ❸ secondary power switch, raise front door ❹ to closed position.

1.8

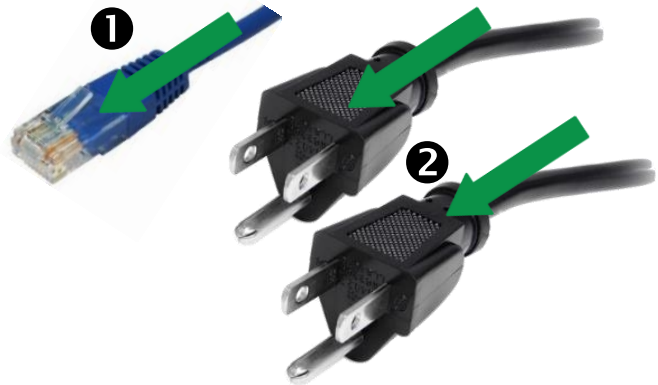

❶ Connect network cable to wall jack (if not already plugged in) then ❷ plug in power cords from processor and enablement kit into wall outlets.

1.10



Android Pad UI Reset Key shown (press briefly to wake UI, if required).

1.12



UI displays splash and status screens. **Note: machine will reboot several times.**



### 1.13

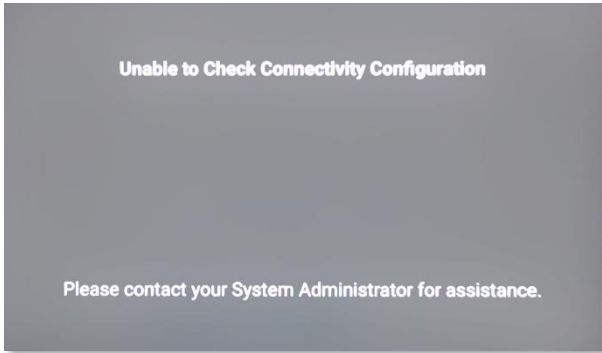

### 1.14



**Note: if UI displays this message for more than 2 minutes see Step 2.1, Section 2 - Troubleshooting.**

Finisher Output Tray will move up to “Home” position.

### 1.15

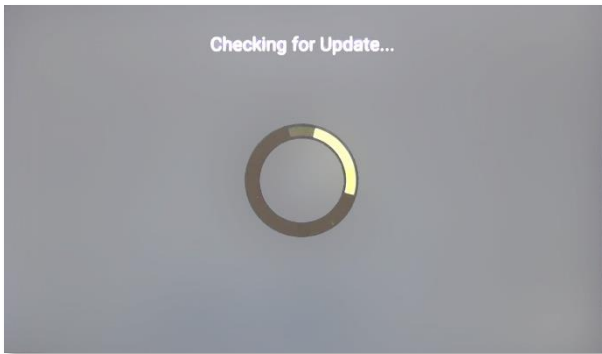

### 1.16

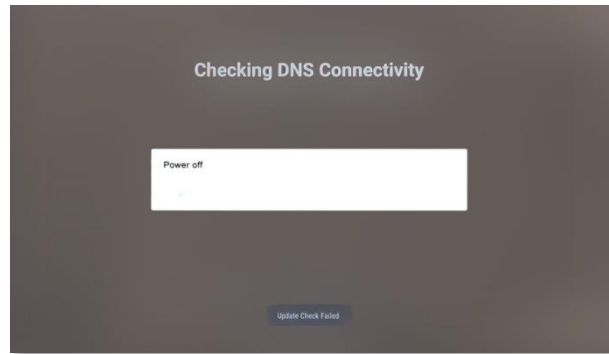

After approximately 1-2 minutes the **Checking for Update...** screen appears indicating machine is booting correctly.

Machine will reboot.

### 1.17

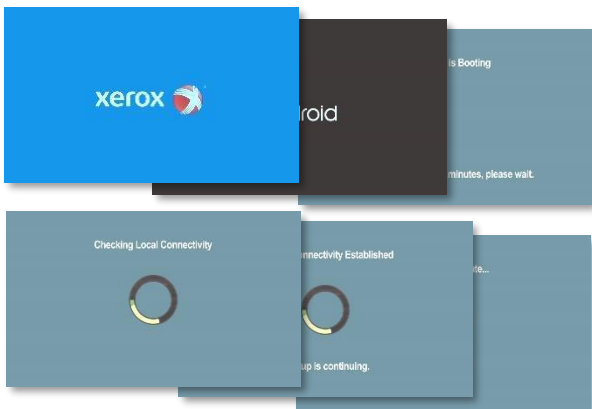

UI again displays splash and status screens.

### 1.18

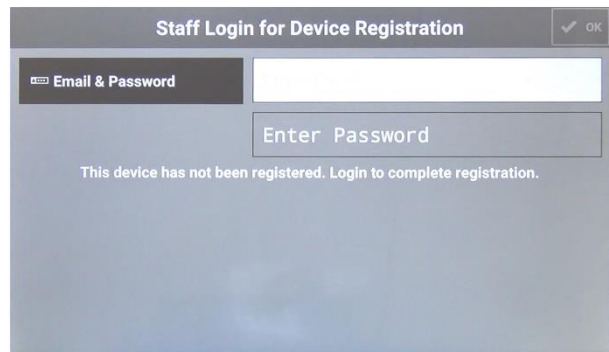

**At Staff Login for Device Registration onsite contact must be present to enter Customer account specific information.**

### 1.19

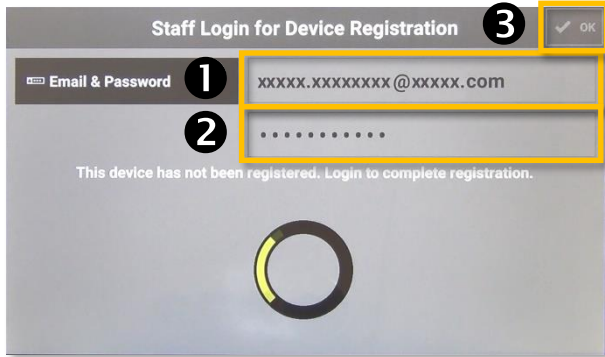

Onsite contact ❶ enters their Customer account specific email address and ❷ password, then ❸ taps ✓ OK. They will now proceed with system registration.

### 1.20

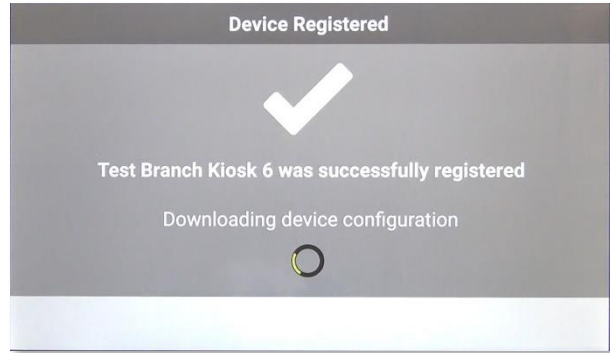

Once completed by onsite contact, **Device Registered** screen shows system is successfully registered and the required activity with onsite contact is concluded.

### 1.21

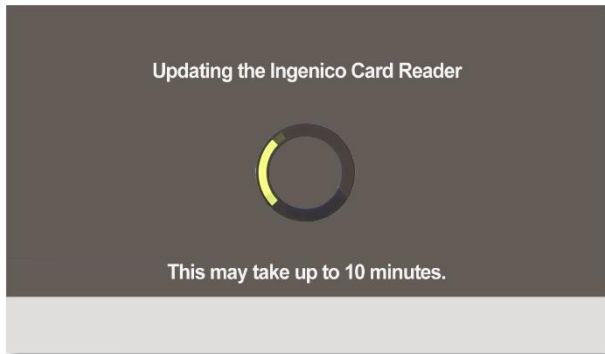

If **Updating the Ingenico Card Reader** screen appears, wait up to 10 minutes while update is installing.

### 1.22

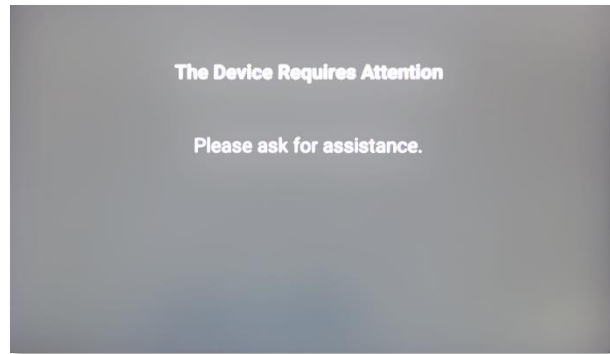

If a Hole Punch module is installed, **The Device Requires Attention** screen will appear. If no Hole Punch module is installed proceed to Step 1.30.

### 1.23

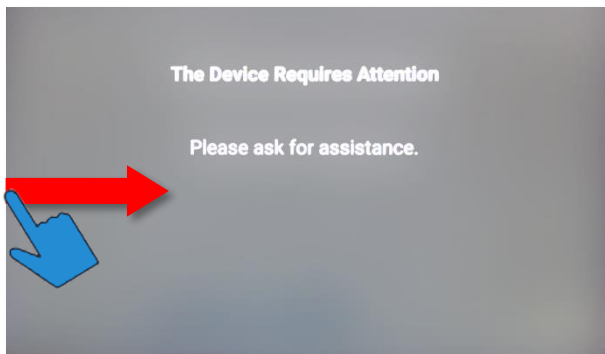

At **The Device Requires Attention** screen, swipe from left edge of UI to reveal **Access** submenu.

### 1.24

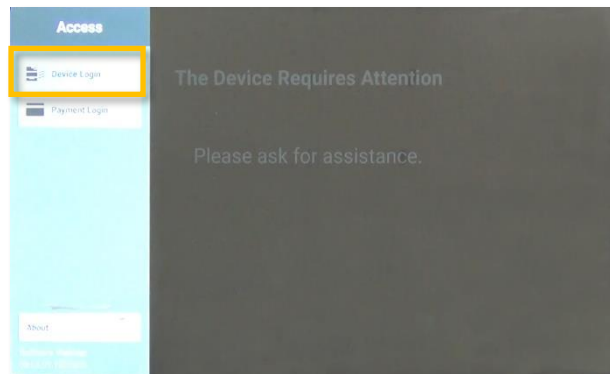

Tap **Device Login** from **Access** submenu.

### 1.25

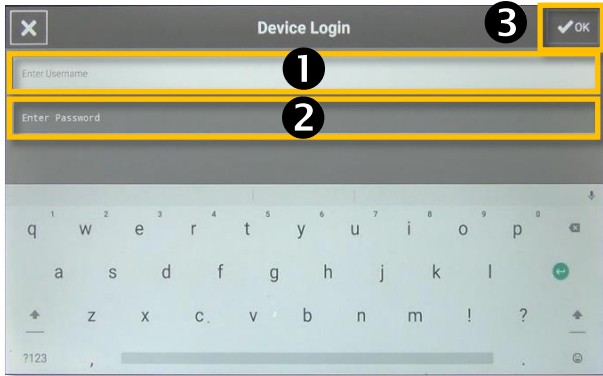

- ❶ Tap **Enter Username**, enter “assoc”. ❷ Tap **Enter Password**, enter “#New--Associate” (case sensitive).
- ❸ Tap **✓OK** when completed.

### 1.26

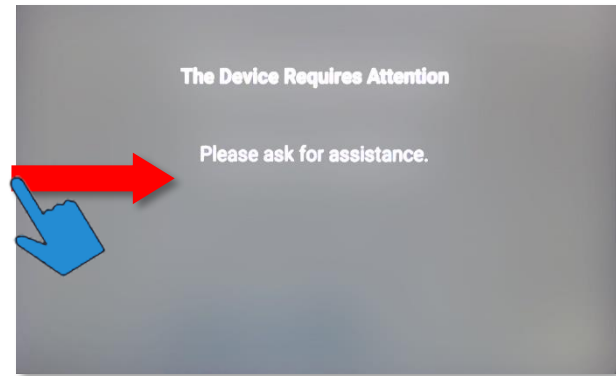

At **The Device Requires Attention** screen, swipe from left edge of UI (if necessary) to reveal **Device** submenu.

### 1.27

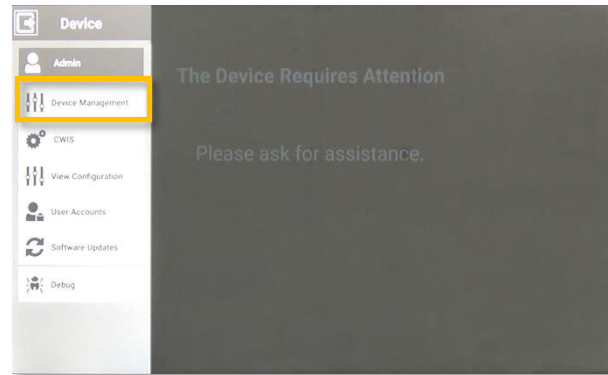

Tap **Device Management** from **Device** submenu.

### 1.28

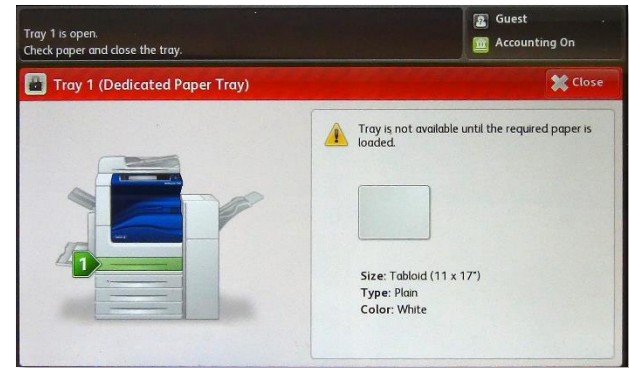

If a tray fault screen appears on UI, follow directions to address problem. Additional Troubleshooting areas are listed in **Step 2.8 in Section 2. Troubleshooting**.

### 1.29

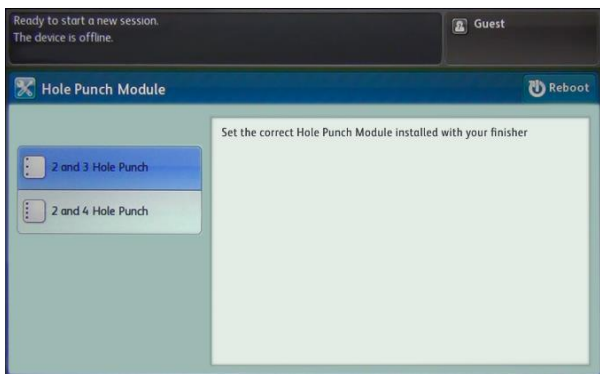

- ❶ Tap **2 and 3 Hole Punch**. ❷ Tap **Reboot**.

### 1.30

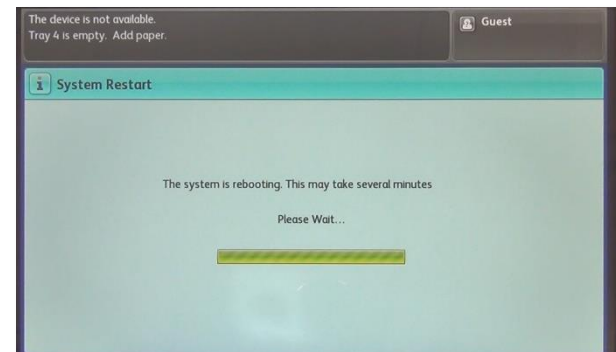

System will reboot.

1.31

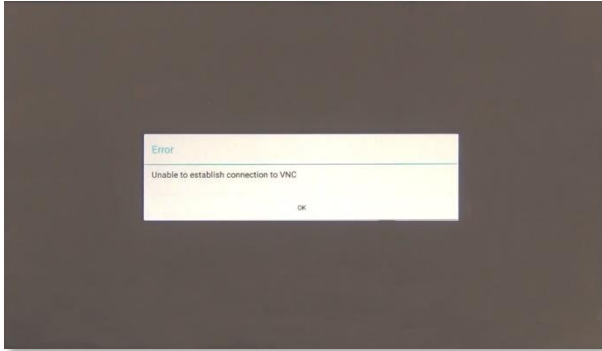

System will display an **Error** screen. **Note: do not tap OK button at this time.**

1.32



Max. 4 min.

If more than 4 minutes pass and Configuration Report does not print, refer to **Step 2.8, Section 2. Troubleshooting** for further actions.

1.33

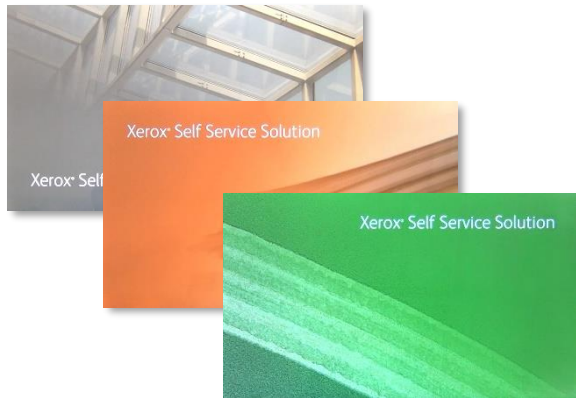

System will display various screen saver images while it continues to boot.

1.34



Wait for Configuration Report to print.

1.35



Once Configuration Report has printed, tap anywhere on UI screen while screen savers are displayed.

1.36



Tap **OK** on the **Error** popup message.

### 1.37

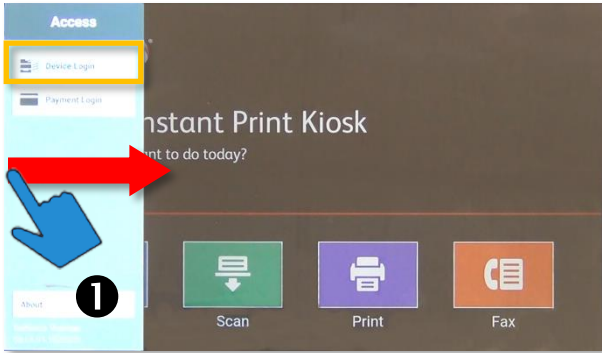

At main **Copy Scan Print Fax** screen, ❶ swipe from left edge of UI to reveal **Access** submenu. ❷ Tap **Device Login**.

### 1.38

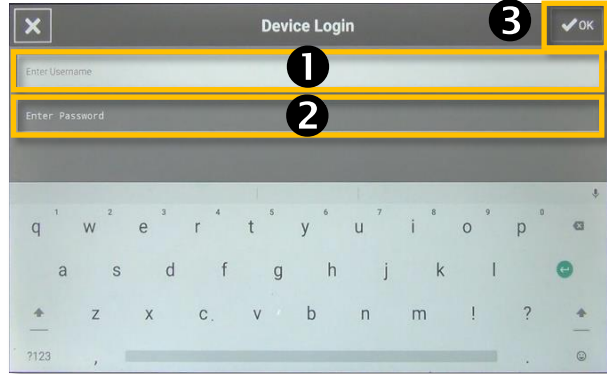

❶ Tap **Enter Username**, enter “assoc”. ❷ Tap **Enter Password**, enter “#New--Associate” (case sensitive). ❸ Tap ✓ **OK** when completed.

### 1.39

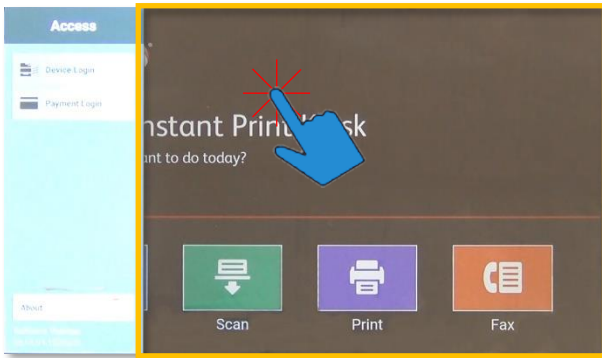

If required, tap outside **Access** sub-menu to close.

### 1.40

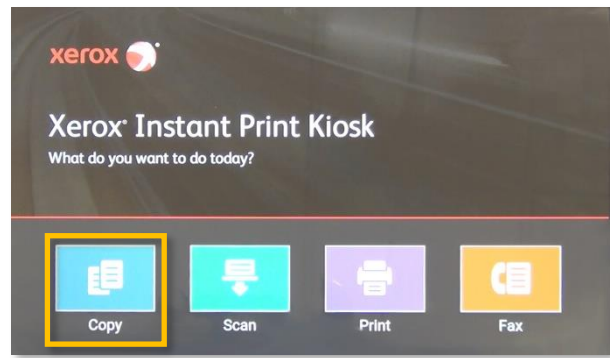

Tap **Copy**.

### 1.41

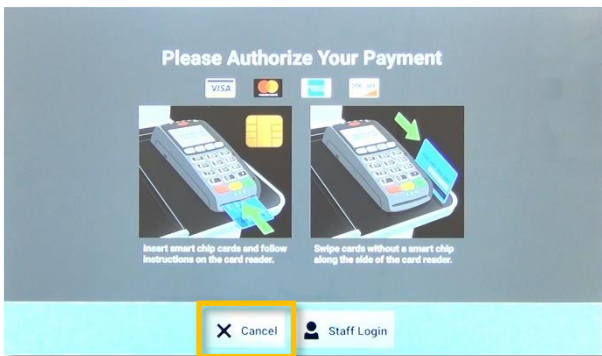

At **Please Authorize Your Payment** screen, tap ✕ **Cancel**.

### 1.42

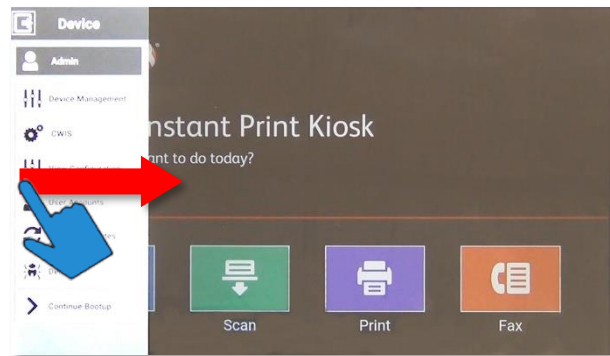

System returns to main **Copy Scan Print Fax** screen. **Note:** if **Device** submenu does not appear, swipe from left edge to open.



### 1.43

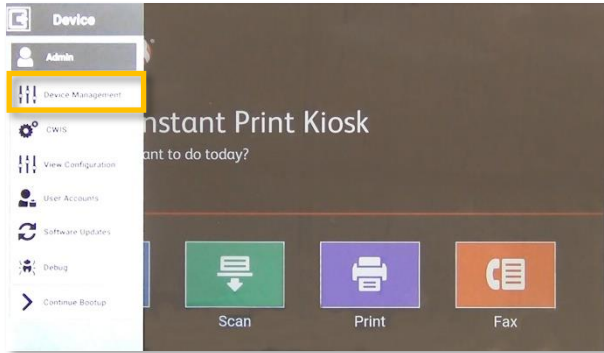

Tap **Device Management**.

### 1.44

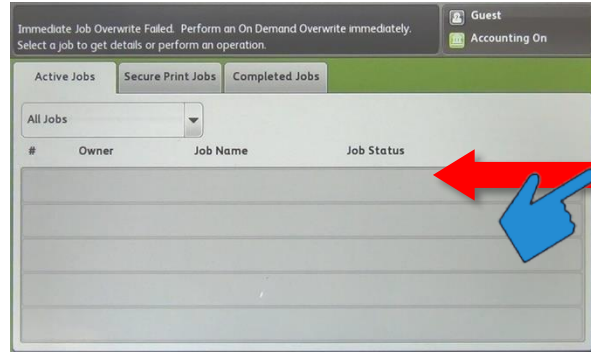

Swipe from right edge of UI to reveal **Tools** submenu.

### 1.45

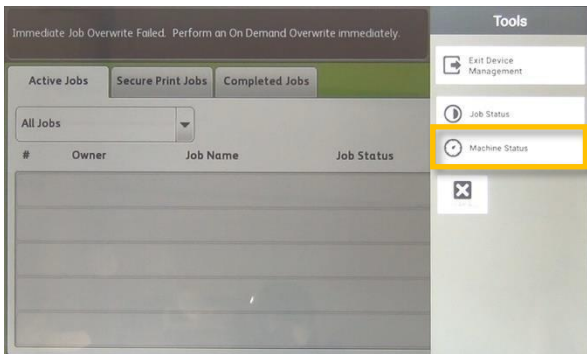

Tap **Machine Status**.

### 1.46

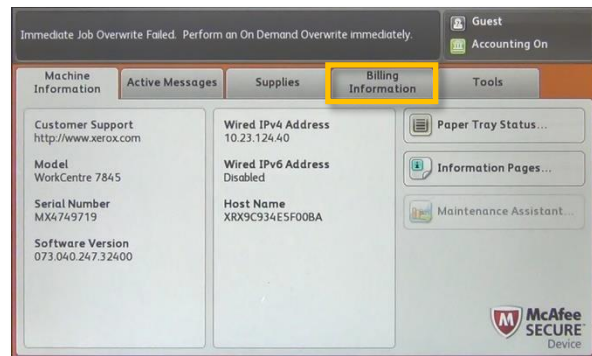

Tap **Billing Information**.

### 1.47

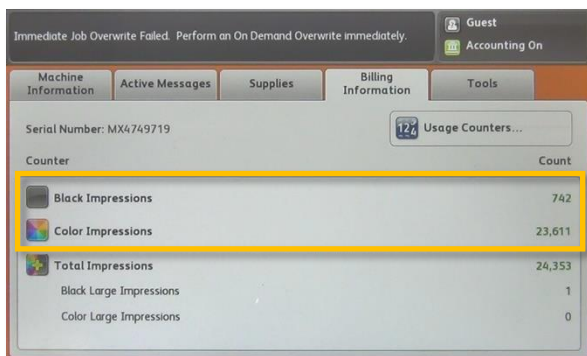

Record **Counter(s)**.

### 1.48

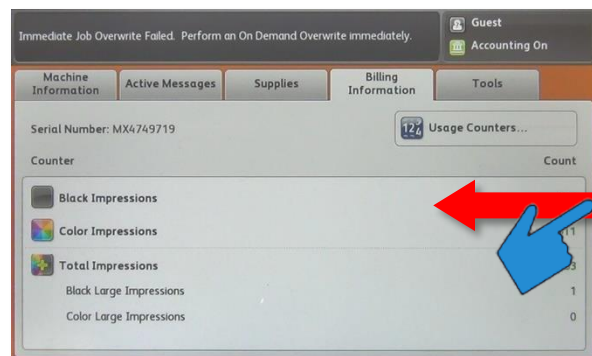

Swipe from right edge of screen to reveal **Tools** submenu.

1.49

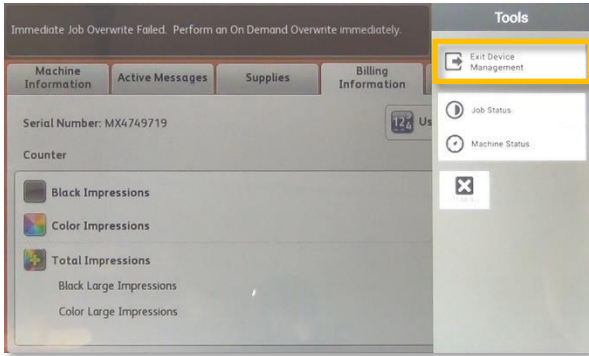

Tap  **Exit Device Management**.

1.50

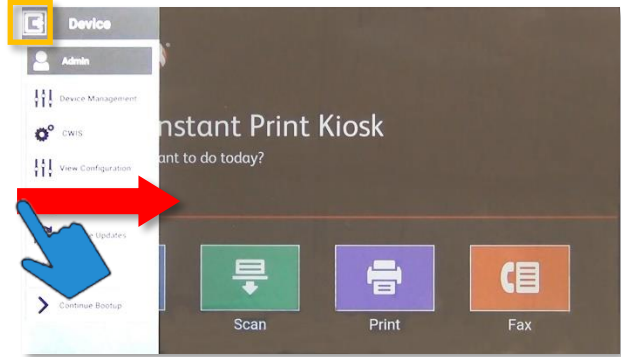

At main **Copy Scan Print Fax** screen tap  **Exit** icon on **Device** submenu. **Note: if Device submenu does not appear, swipe from left edge to open.**

1.51

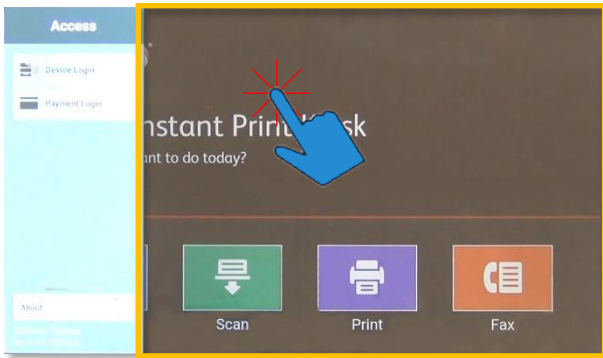

If required, tap outside **Access** submenu to close.

1.52

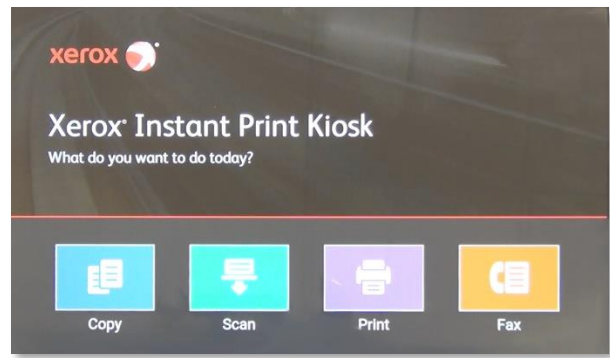

Main **Copy Scan Print Fax** screen is shown on UI.

1.53



Give Initialization Kit, Multifunction Kiosk Security Kit, Toner Waste Container, and any remaining items and/or kits to onsite contact for storage.

1.54



Double check network connections at wall jack and machine.



1.55



Retrieve **Configuration Report** and **Installation and Relocation Guide**.



End of procedure.

## 2. Troubleshooting

2.1

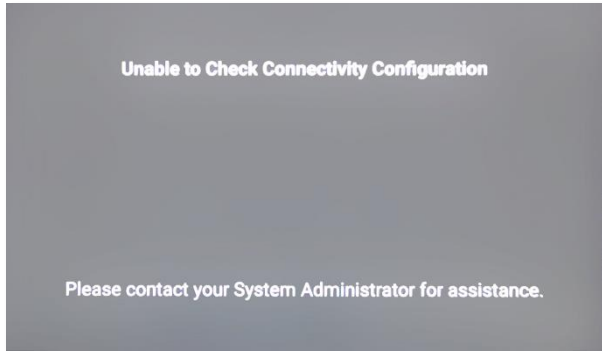

2.2

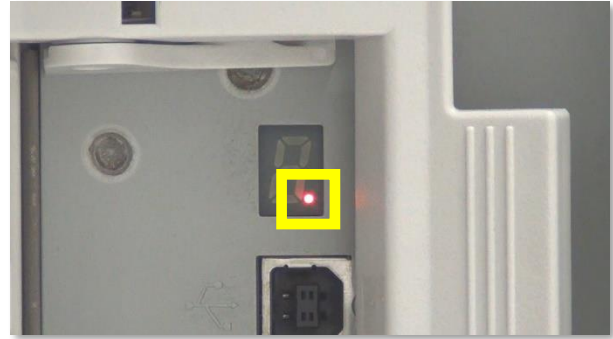

If UI displays this message for more than 2 minutes check 7-segment LED in right rear corner connections area (remove corner cover to view).

After approximately 2 minutes, proper display is a single flashing dot.

2.3

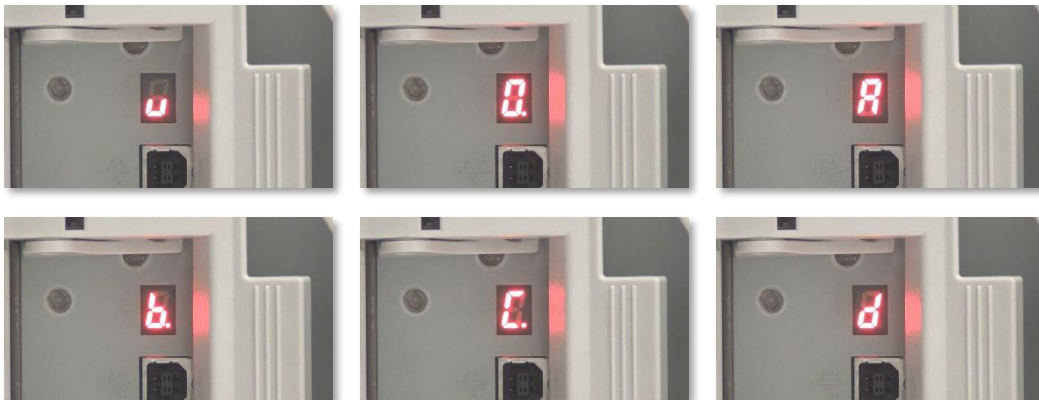

If UI is displaying any sequence of numbers / letters after 2 minutes, machine must be rebooted.

2.4

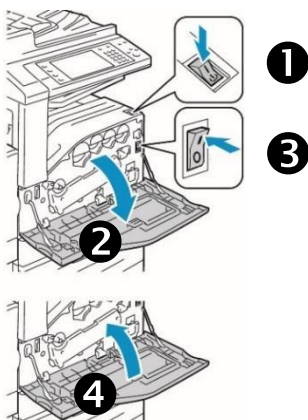

Switch off ❶ secondary power switch, lower ❷ front door to open position, switch off ❸ primary power switch, raise ❹ front door to closed position.

2.5

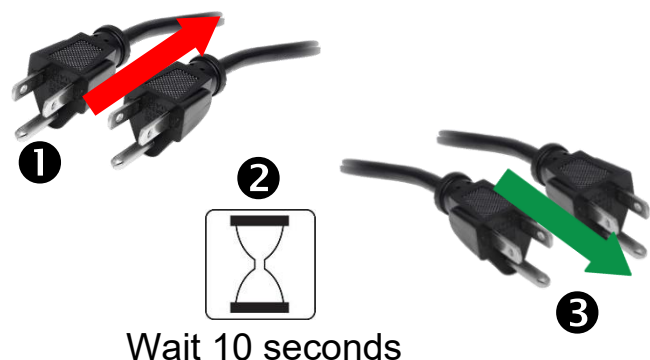

❶ Unplug both power cords from wall outlet, ❷ wait 10 seconds, then ❸ plug both cords back into wall outlet.

2.6

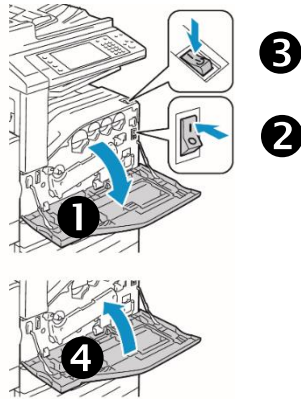

Lower front door ❶ to open position, switch on ❷ primary power switch, switch on ❸ secondary power switch, raise front door ❹ to closed position.

2.7

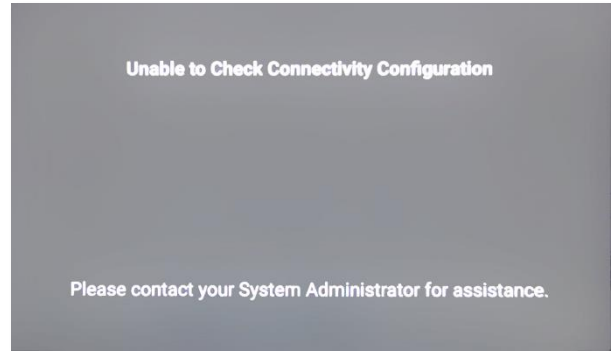

If problem reoccurs (machine hangs at this screen) abort install. Otherwise return to Step 1.13 and continue.

2.8



If UI shows a Paper Tray Error, or Configuration Report does not print, check status of these items, in order:

- ❶ Make sure all trays contain correct paper size, and paper guides are set correctly
- ❷ Open and close Horizontal Transport
- ❸ Open and close both left side doors
- ❹ Open and close front door
- ❺ Open and close Finisher top baffle door
- ❻ Make sure Finisher is correctly seated against machine.

## 3. Relocation

### 3.1

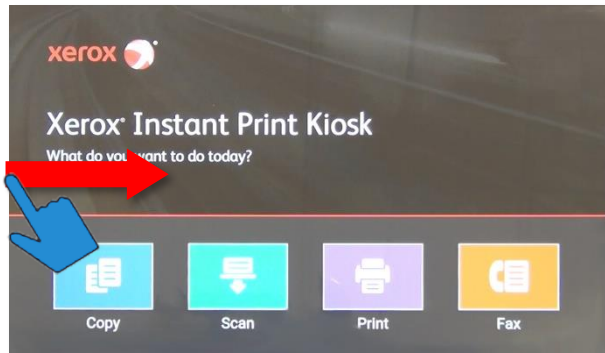

At main **Copy Scan Print Fax** screen swipe from left side of screen to reveal **Access** submenu.

### 3.2

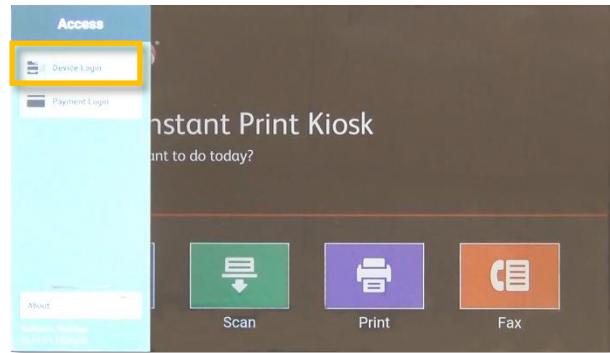

Tap **Device Login**.

### 3.3

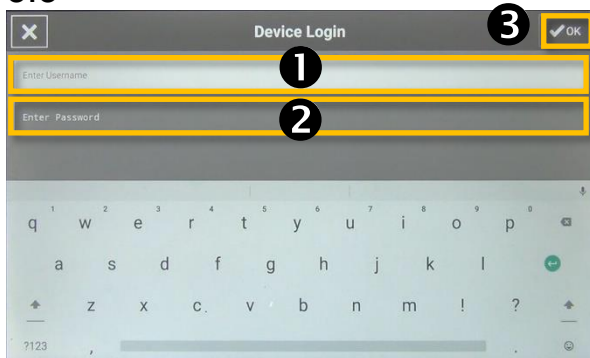

❶ Tap **Enter Username**, enter "assoc". ❷ Tap **Enter Password**, enter "#New--Associate" (case sensitive). ❸ Tap **✓OK** when completed.

### 3.4

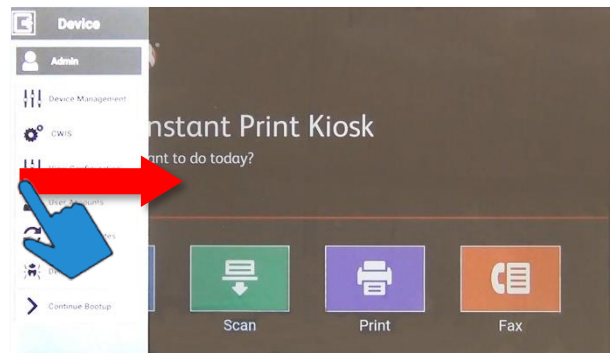

System returns to main **Copy Scan Print Fax** screen. Swipe from left edge to open **Device** submenu.

### 3.5

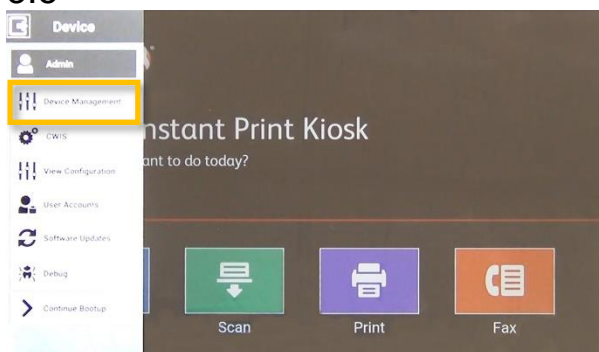

Tap **Device Management**.

### 3.6

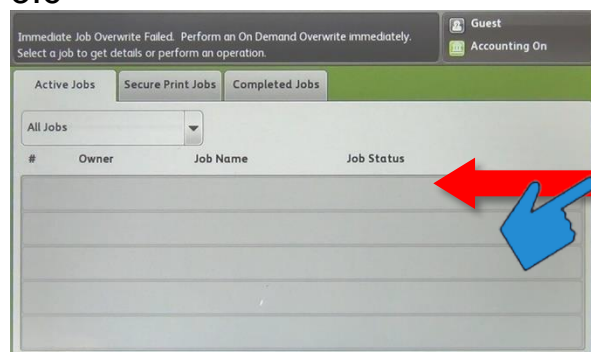

Swipe from right edge of UI to reveal **Tools** submenu.

### 3.7

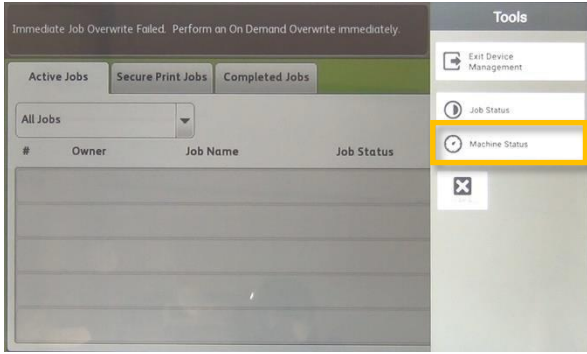

Tap **Machine Status**.

### 3.8

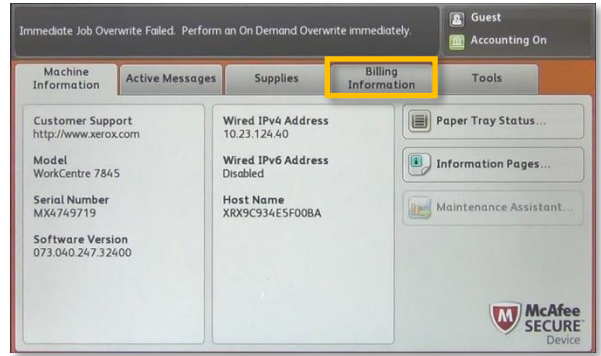

Tap **Billing Information**.

### 3.9

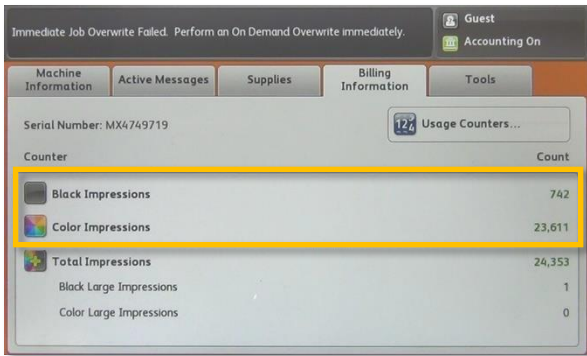

Record **Counter(s)**.

### 3.10

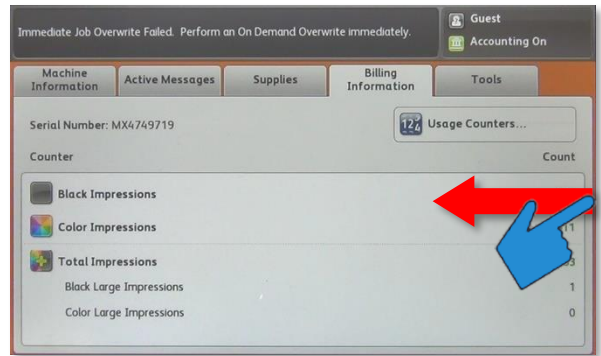

Swipe from right edge of screen to reveal **Tools** submenu.

### 3.11

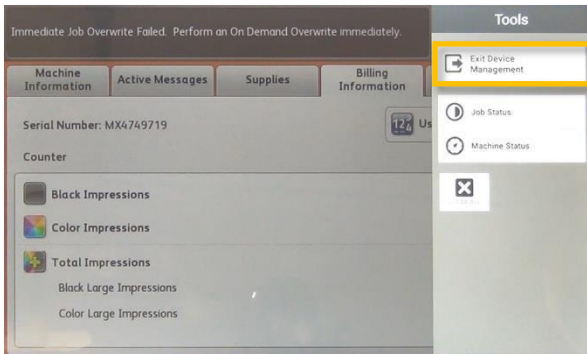

Tap **Exit Device Management**.

### 3.12

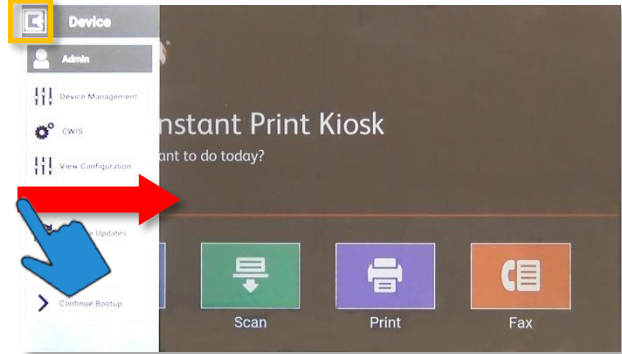

Tap **Exit** icon on **Device** submenu. **Note: if Device submenu does not appear, swipe from left edge to open.**



### 3.13

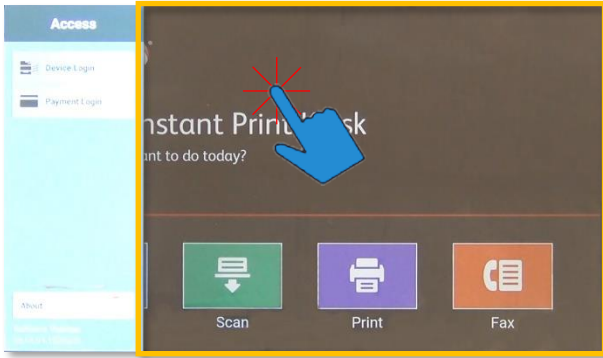

If required, tap outside **Access** sub-menu to close.

### 3.14

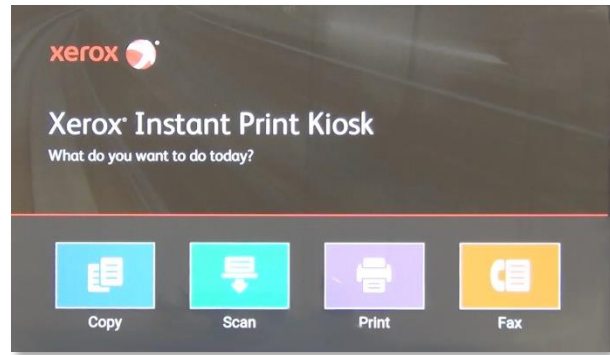

Main **Copy Scan Print Fax** screen is displayed.

### 3.15

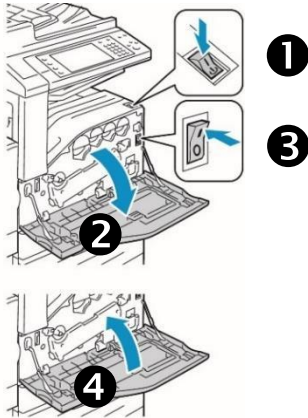

Switch off ❶ secondary power switch, lower ❷ front door to open position, switch off ❸ primary power switch, raise ❹ front door to closed position.

### 3.16

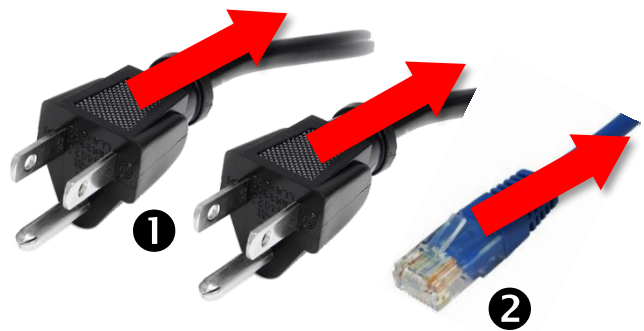

❶ Unplug processor and enablement kit power cords from wall outlet, then ❷ disconnect network cable from wall jack.

### 3.17

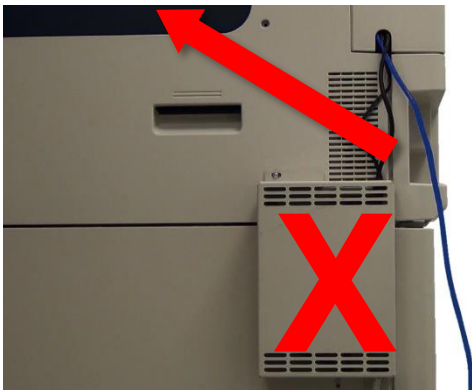

Coil and secure network cable in output cavity. **Do not disconnect network cable from machine or remove enablement kit enclosure.**

### 3.18



Obtain Multifunction Kiosk Security Kit from onsite contact. You will be providing to new location point of contact later in procedure (Step 3.38).

### 3.19

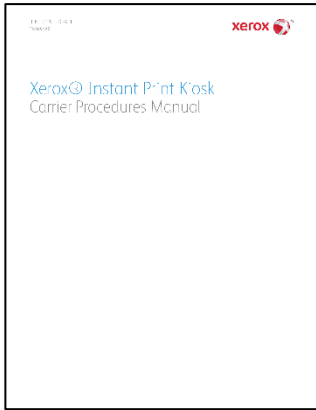

Refer to **Section 5 - Relocation/Removal of Xerox® Instant Print Kiosk Carrier Procedures Manual** to relocate machine.

### 3.20

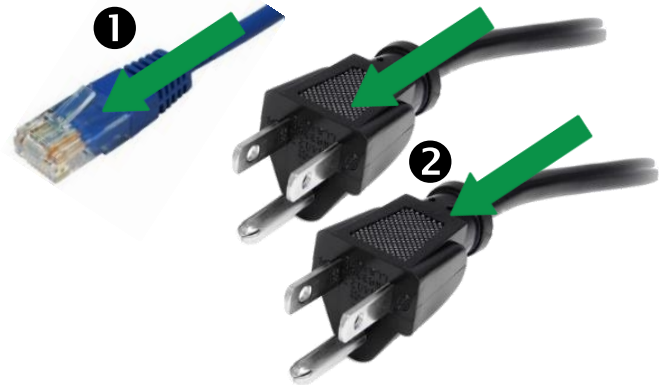

1 Connect network cable to wall jack (if not already plugged in) then 2 plug in power cords from processor and enablement kit into wall outlets.

### 3.21

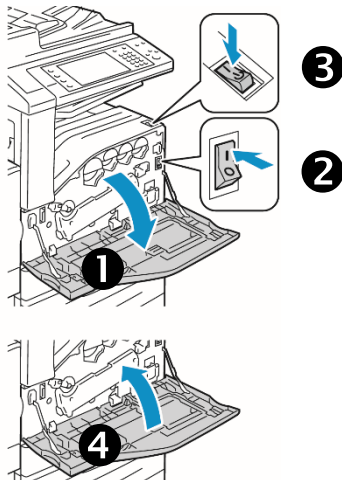

Lower 1 front door to open position, switch on 2 primary power switch, switch on 3 secondary power switch, raise 4 front door to closed position.

### 3.22



**NOTE: If Android Pad UI display goes dark at any point while booting, press Reset Key (shown in Step 3.23) briefly to wake.**

### 3.23



Android Pad UI Reset Key shown (press briefly to wake UI, if required).

### 3.24



UI displays splash and status screens. **Note: machine will reboot several times.**



### 3.25

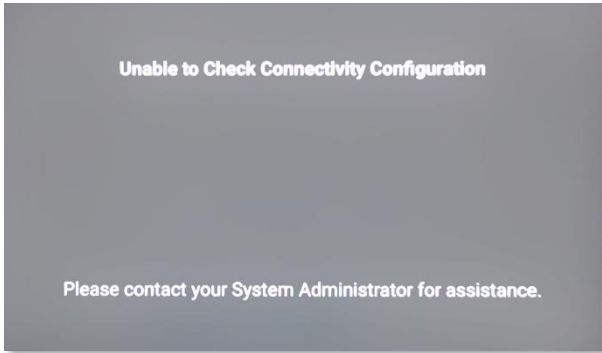

### 3.26

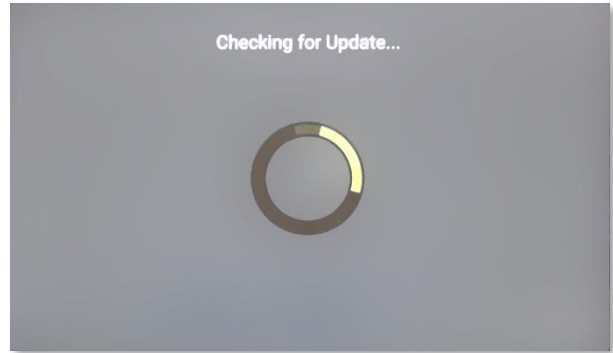

**Note: If UI displays this message for more than 2 minutes see Step 2.1, Section 2 - Troubleshooting.**

After approximately 1-2 minutes the **Checking for Update...** screen appears indicating machine is booting correctly.

### 3.27

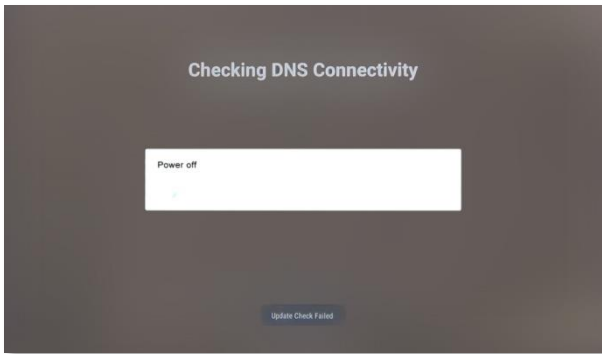

### 3.28



Machine will reboot.

UI again displays splash and status screens.

### 3.29



A Configuration Report will print once network connectivity is fully established and boot is complete.

### 3.30



Once Configuration Report has printed, tap anywhere on UI screen while screen savers are displayed.

### 3.31



Tap **OK** on the **Error** popup message.

### 3.32

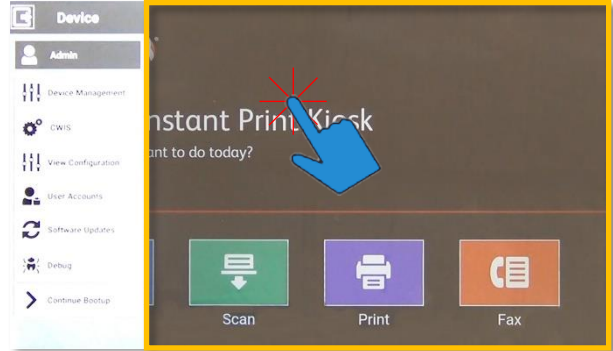

If necessary, tap outside **Device** submenu to close submenu.

### 3.33

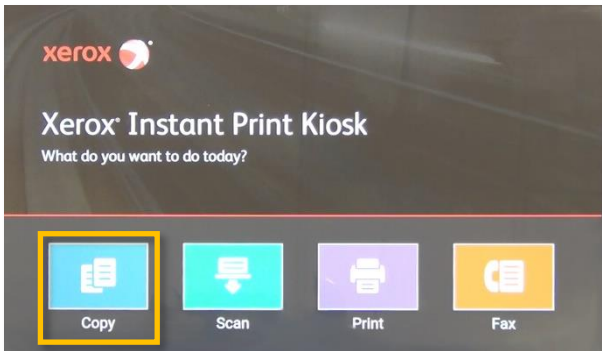

Tap **Copy**.

### 3.34

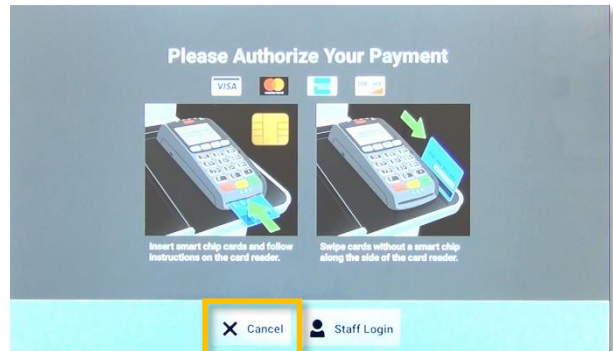

At **Please Authorize Your Payment** screen, tap **X Cancel**.

### 3.35

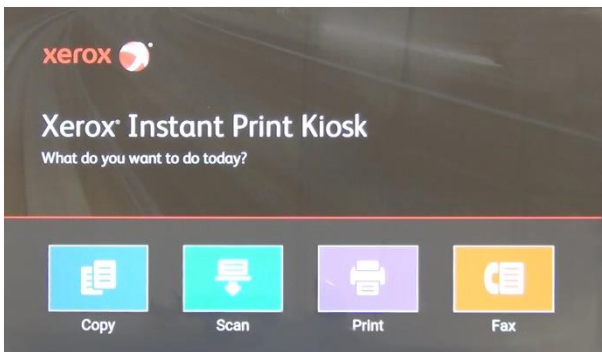

System returns to main **Copy Scan Print Fax** screen.

### 3.36



Double check network connections at wall jack and machine.

3.37



Retrieve **Configuration Report** and **Installation and Relocation Guide**.

3.38



**Multifunction Kiosk Security Kit MUST be left with acting onsite contact**

Give Multifunction Kiosk Security Kit and any other remaining items to Customer for storage.



End of procedure.

# Xerox<sup>®</sup> Adaptive CMYK Plus Technology Cart

## Carrier Procedures Manual

© 2019 Xerox Corporation. All rights reserved. Xerox® is a trademark of Xerox Corporation in the United States and/or other countries.

Printed in the United States of America.

Changes are periodically made to this document. Changes, technical inaccuracies, and typographic errors will be corrected in subsequent editions.

Document Version: 1.0 (June 2019).

## Revision Control List

All pages are June 2019 unless otherwise specified.

Page	Issue

Page	Issue

This document is intended for use by authorized Logistic Service Providers only and is not for resale.

This document describes the Pre-Install process steps/packaging items that must be used to ensure the product can be safely shipped after Pre-Install before shipping to the Customer.

While every care has been taken in the preparation of this manual, no liability will be accepted by Xerox arising out of the use of this manual including, but not limited to, inaccuracies or omissions.

Any damage / installation failures caused by Pre-Installation steps deviating from the described process in this document will be at your own risk, no warranty replacements will be guaranteed.

### Notes:

Notes are signified by the use of the Info symbol. The word Note is not used in Carrier manuals. A note is used to alert personnel to a procedure, practice, condition or statement that is necessary to accomplish a task efficiently.

Notes usually precede the step describing the action that needs additional explanation, but may follow the step if necessary for clarity.

### Cautions:

A Caution is used whenever a procedure, practice, condition, or statement, if not strictly observed, could result in damage to the equipment. Cautions are identified with an Alert symbol and the word CAUTION (all caps) at the beginning of the paragraph.

Cautions ALWAYS precede the step with the action.

### Warning:

Warnings are used whenever a procedure, practice, condition, or statement, if not strictly observed, could result in personal injury or death. Warnings are identified with the appropriate warning symbol and the word WARNING (all caps, bold) at the beginning of the paragraph. When a specific warning symbol is not available an "Alert" symbol will be used to identify.

Warnings ALWAYS precede the step with the action.

# Table of Contents

<b>Section 1: General Information .....</b>	<b>1-1</b>
General Information .....	1-2
Product Codes and Part Numbers .....	1-2
Packaged Product Weights and Sizes .....	1-2
Unpackaged Product Weights and Sizes .....	1-2
<b>Section 2: LSP - Configuration .....</b>	<b>2-1</b>
LSP - Configuration Processes .....	2-2
Tools Required.....	2-2
Moving the Xerox® Adaptive CMYK Plus Technology Cart to the Truck.....	2-2
<b>Section 3: Warehouse3-1</b>	
Warehouse.....	3-2
Tools Required.....	3-2
Moving the Xerox® Adaptive CMYK Plus Technology Cart to the Truck.....	3-2
<b>Section 4: Delivery4-1</b>	
Delivery.....	4-2
Tools Required.....	4-2
Moving and Strapping the Xerox® Adaptive CMYK Plus Technology Cart to the Truck.....	4-2
Special Handling .....	4-3
Turning Radii .....	4-4
Space Requirements.....	4-4
Unpacking and Positioning the Xerox® Adaptive CMYK Plus Technology Cart ..	4-5
<b>Section 5: Relocation/Removal5-1</b>	
Relocation/Removal .....	5-2
Materials Required .....	5-2
Preparing the Xerox® Adaptive CMYK Plus Technology Cart for the Relocation/Return .....	5-2
Complex Relocation .....	5-5
Moving and Strapping the Xerox® Adaptive CMYK Plus Technology Cart to the Truck (if required) .....	5-5
Position the Xerox® Adaptive CMYK Plus Technology Cart at the New Location	5-6
<b>Section 6: Repack and Return6-1</b>	
Repack and Return.....	6-2
Repacking Processes for the Xerox® Adaptive CMYK Plus Technology Cart .....	6-2
Repacking the Xerox® Adaptive CMYK Plus Technology Cart for Return .....	6-2
<b>Section 7: Accessories .....</b>	<b>7-1</b>
This Section does not apply	



Section 8: Ready to Run ..... 8-1

This Section does not apply



# General Information

1

Product	Product Code/ Part Numbers North America (60Hz)	Install Responsibility North America	Product Code/ Part Numbers Europe (50Hz)	Install Responsibility Europe
Xerox® Adaptive CMYK Plus Technology Cart (Vivid Toner Kit)	MQD/097N02369	Carrier (Unpack/ Position)	MQD/097N02369	LSP (Unpack/ Position)
Xerox® Adaptive CMYK Plus Technology Cart (Florescent Toner Kit)	MQE/097N02370	Carrier (Unpack/ Position)	MQE/097N02370	LSP (Unpack/ Position)
Xerox® Adaptive CMYK Plus Technology Cart (Combined Vivid + Florescent Toner Kits)	MQF/097N02371	Carrier (Unpack/ Position)	MQF/097N02371	LSP (Unpack/ Position)

Table 1.1.1

Product Code/Part Number	Packaged Weight		Packaged Size (W x D x H)	
	kg	lb	mm	in
Xerox® Adaptive CMYK Plus Technology Cart	93	205	997 x 819 x 851	39.25 x 32.25 x 33.5

Table 1.2.1

Product Code/Part Number	Unpackaged Weight		Unpackaged Size (W x D x H)	
	kg	lb	mm	in
Xerox® Adaptive CMYK Plus Technology Cart	67	147.5	924 x 711 x 705	36.5 x 28 x 27.75

Table 1.3.1

## 1.0.0 General Information

### 1.1.0 Product Codes and Part Numbers

1.1.1 Product codes and part numbers for the Xerox® Adaptive CMYK Plus Technology Cart are shown in Table 1.1.1.

### 1.2.0 Packaged Product Weights and Sizes

1.2.1 Packaged weights and sizes for the Xerox® Adaptive CMYK Plus Technology Cart system are shown in Table 1.2.1.

## 1.3.0 Unpackaged Product Weights and Sizes

1.3.1 Unpackaged weights and sizes for the Xerox® Adaptive CMYK Plus Technology Cart are shown in Table 1.3.1.

# LSP - Configuration Europe Only

# 2

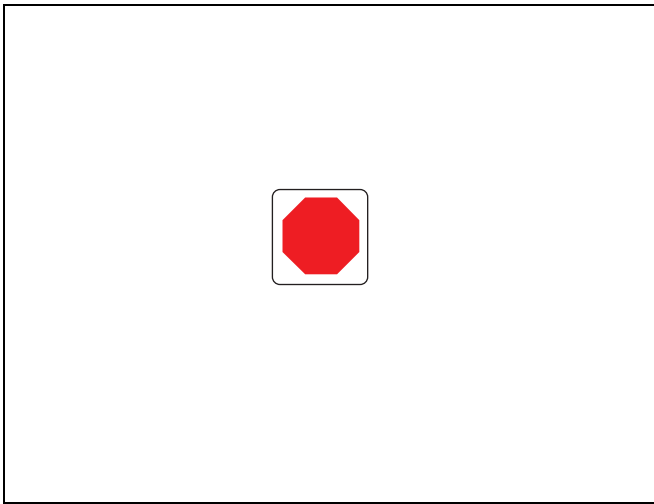
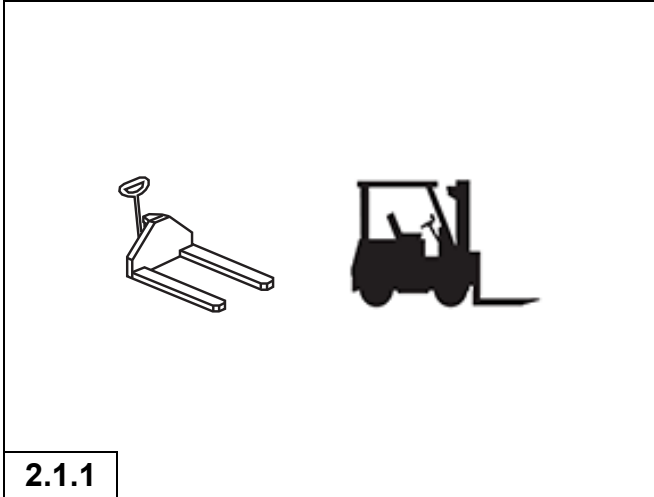

## 2.0.0 LSP - Configuration Processes

### 2.1.0 Tools Required

2.1.1 Tools for moving the Xerox® Adaptive CMYK Plus Technology Cart to the truck are shown.



Note: Do not depalletize or unpack the Xerox® Adaptive CMYK Plus Technology Cart. Transport it to the Customer site in its original packaging and on its original pallet.

### 2.2.0 Moving the Xerox® Adaptive CMYK Plus Technology Cart to the Truck

2.2.1 Place the cart on its pallet on a pallet jack or use a forklift and move the cart and pallet onto the truck.



Note: This concludes the LSP - Configuration procedures for the Xerox® Adaptive CMYK Plus Technology Cart.

# Warehouse

# 3



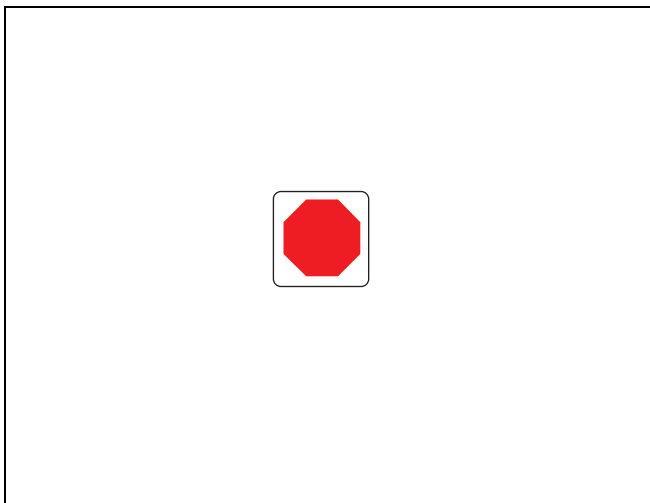
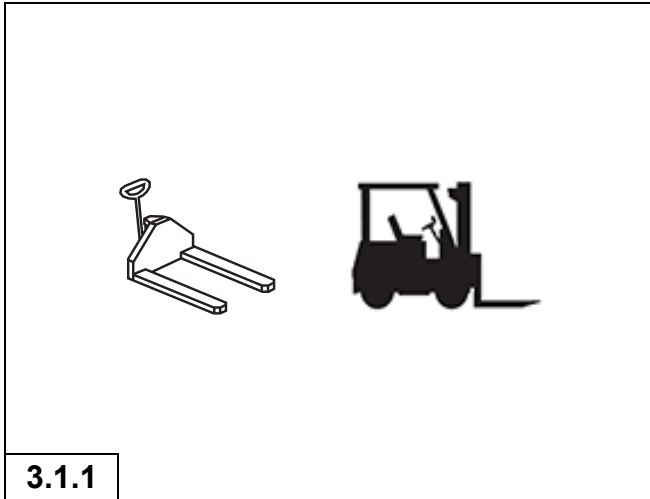

### 3.0.0 Warehouse

#### 3.1.0 Tools Required

3.1.1 Tools for moving the Xerox® Adaptive CMYK Plus Technology Cart to the truck are shown.



Note: Do not depalletize or unpack the Xerox® Adaptive CMYK Plus Technology Cart. Transport it to the Customer site in its original packaging and on its original pallet.

#### 3.2.0 Moving the Xerox® Adaptive CMYK Plus Technology Cart to the Truck

3.2.1 Place the cart on its pallet on a pallet jack or use a forklift and move the cart and pallet onto the truck.



Stop: This concludes the Warehouse procedures for the Xerox® Adaptive CMYK Plus Technology Cart.

# Delivery

# 4

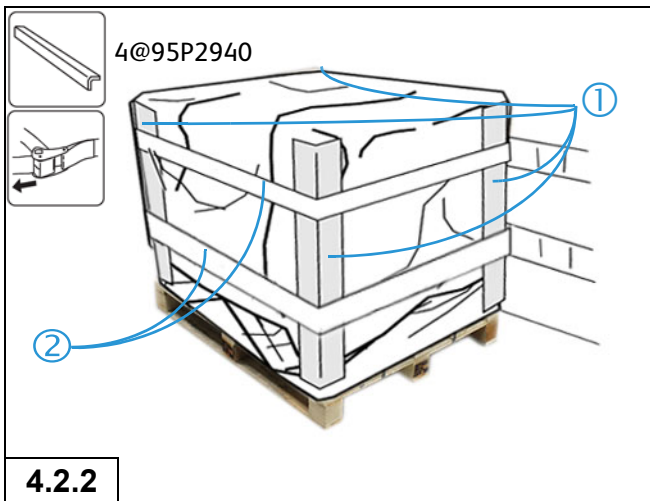
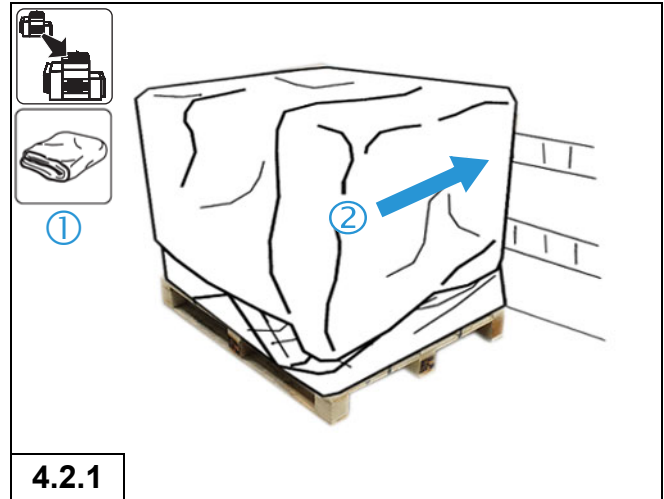
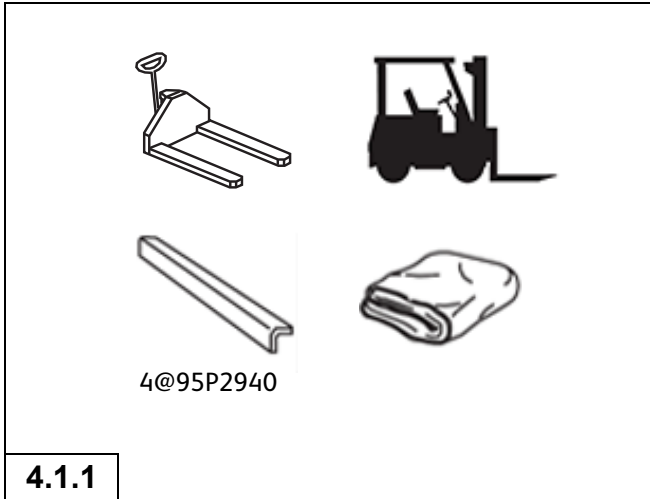

## 4.0.0 Delivery

### 4.1.0 Tools Required

4.1.1 The tools and materials required to move and strap the Xerox® Adaptive CMYK Plus Technology Cart to the truck are shown.

### 4.2.0 Moving and Strapping the Xerox® Adaptive CMYK Plus Technology Cart to the Truck

4.2.1 Once the cart is on the truck, ① cover with a folded blanket and ② position the cart against the wall of the truck.

4.2.2 ① Position a cornerboard (95P2940) on each corner and ② strap the module into the truck with two straps.

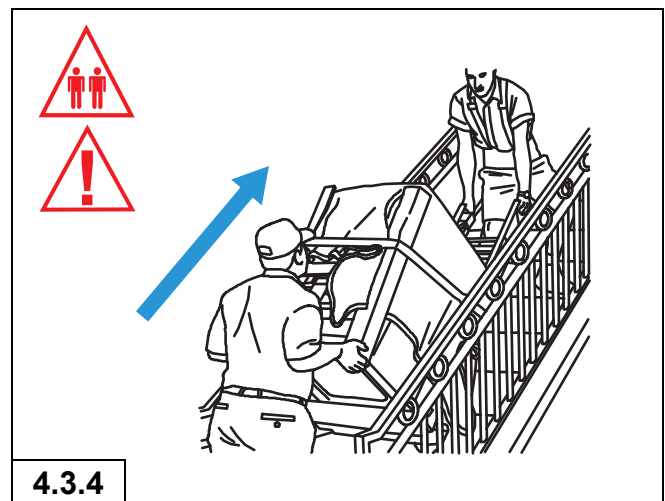
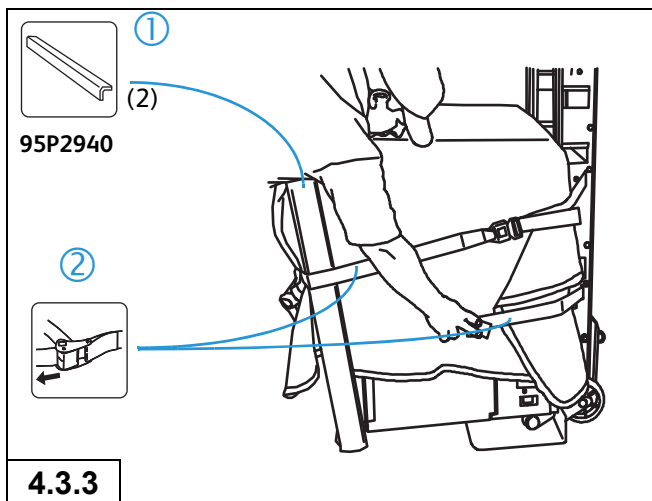
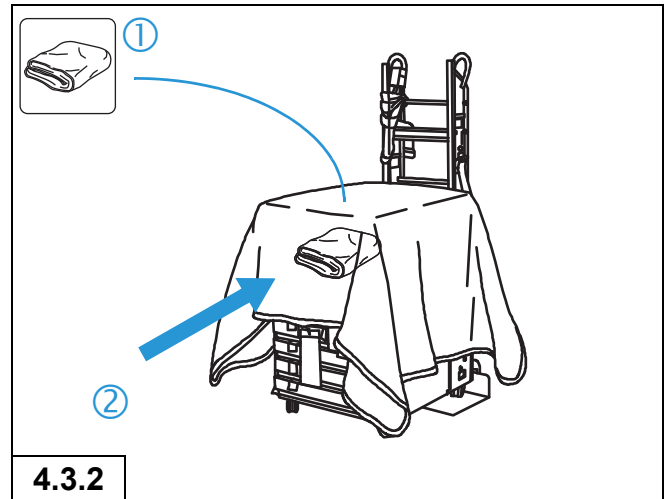
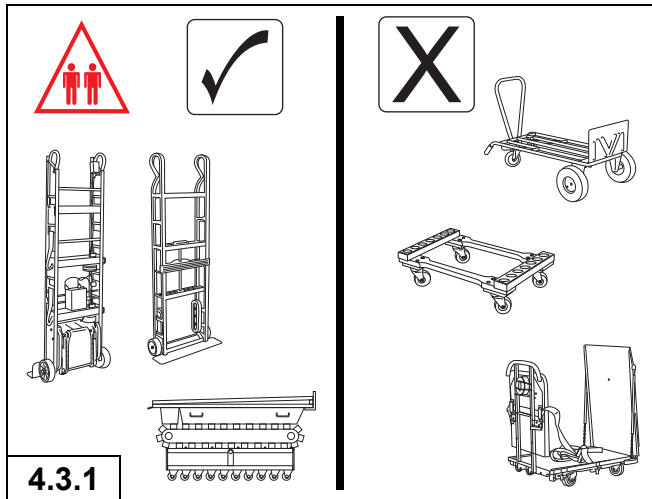

**4.3.0 Special Handling**



**WARNING:** Always use a plate extension on the appliance dolly when transporting the Xerox® Adaptive CMYK Plus Technology Cart to avoid personal injury.

4.3.1 To move the cart up or down the a flight of steps, an escalara is required. If an escalara is not available, a stair climber or appliance dolly with plate extensions may be used.

4.3.2 ① Place a blanket over the cart and ② roll it rear first onto the escalara.

4.3.3 ① Place cornerboards on the cart front left and right edges and ② strap to the escalara.



**WARNING:** Due to the weight of the cart, two people are required when raising or lowering it on a flight of steps.



**CAUTION:** The cart should be tipped only on its rear with the bottom side down when moved up a flight of stairs.

4.3.4 Move the cart up the steps.

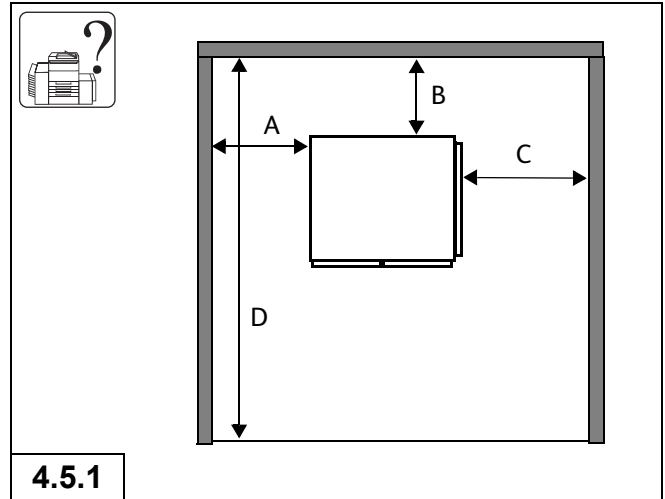
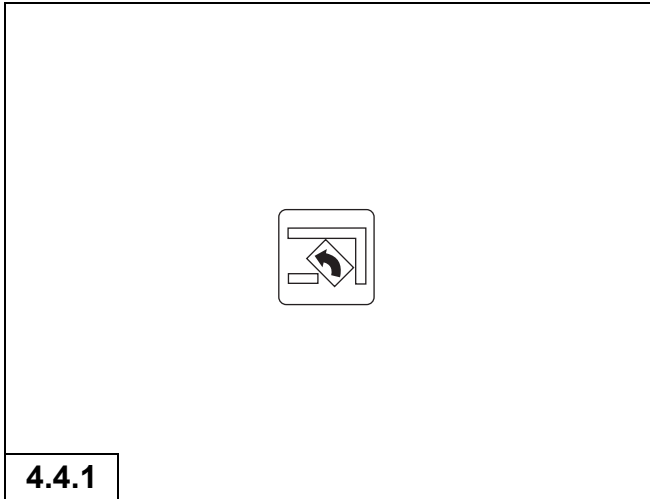

**4.4.0 Turning Radii**

4.4.1 The Xerox® Adaptive CMYK Plus Technology Cart is small enough such that turning radii is not a concern.

**4.5.0 Space Requirements**

4.5.1 The Xerox® Adaptive CMYK Plus Technology Cart is an accessory where space requirements are not a concern.

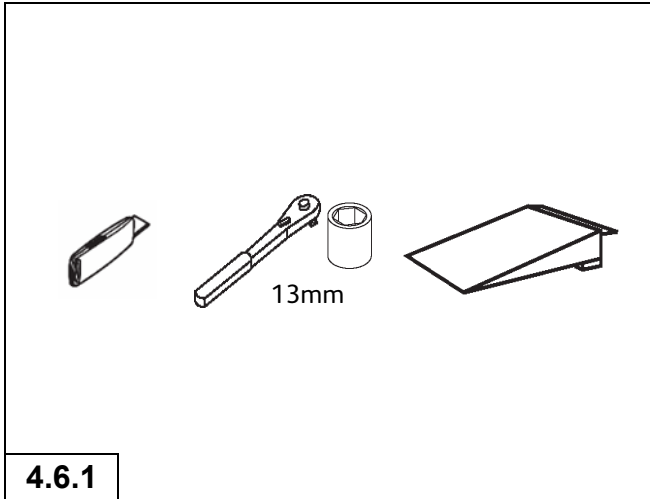

#### 4.6.0 Unpacking and Positioning the Xerox® Adaptive CMYK Plus Technology Cart

4.6.1 Tools and materials for depalletizing and unpackaging the cart are shown.

4.6.2 Cut the banding straps.

4.6.3 Cut open the top flaps of the overpack box.

4.6.4 Fully open the flaps of the box.



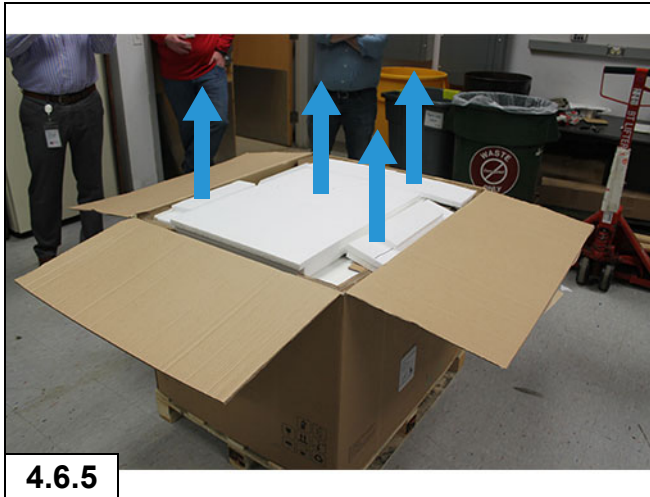

4.6.5

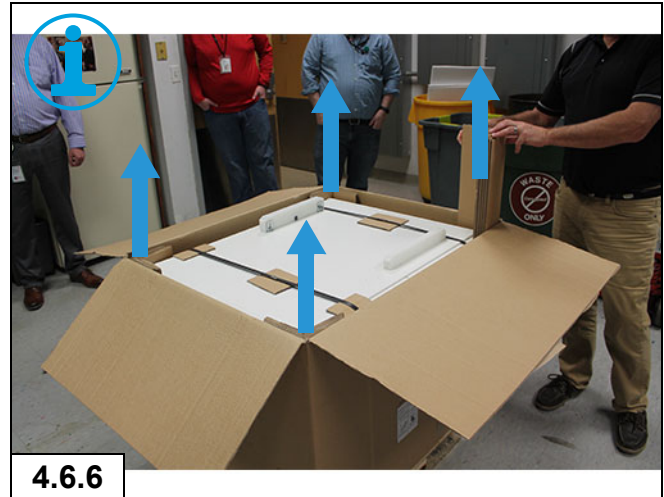

4.6.6



4.6.7

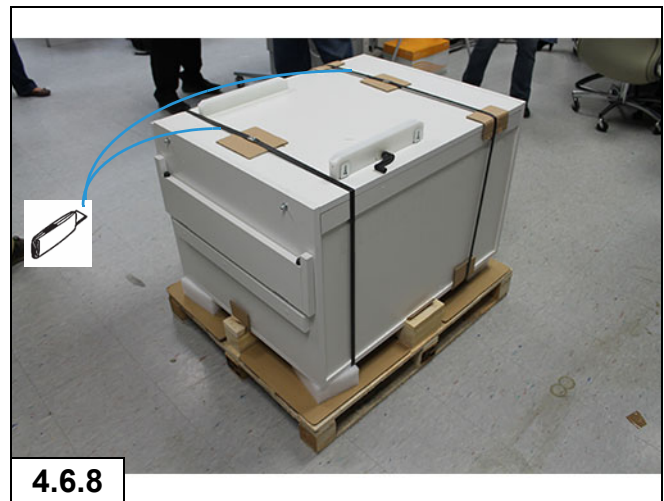

4.6.8

4.6.5 Remove all foam packaging pieces from the top of the cart.



Note: The two top rails may not be present on the Xerox® Adaptive CMYK Plus Technology Cart.

4.6.6 Remove the (4) cornerboards.

4.6.7 Use two people to carefully lift the cardboard overpack up and off the cart.

4.6.8 Cut the (2) banding straps that secure the cart to the pallet.



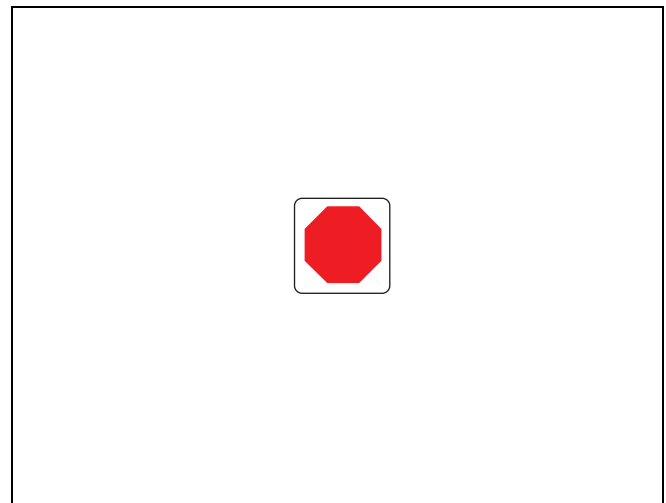
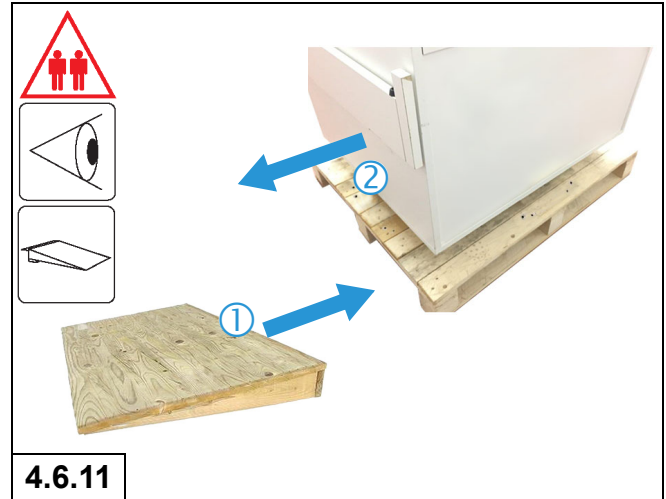
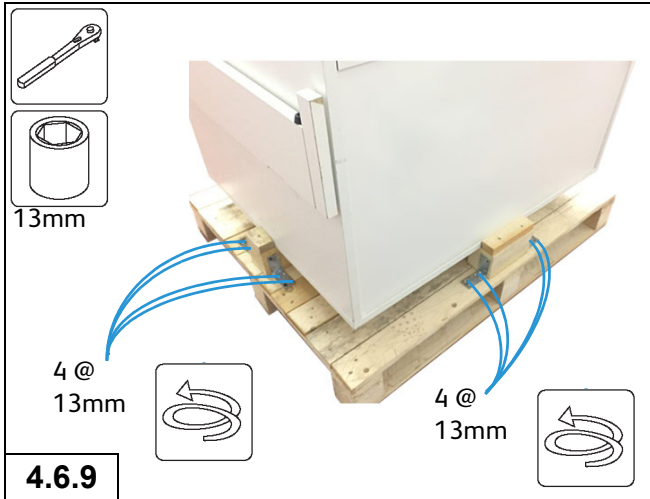

4.6.9 Remove (4) 13mm bolts, blocks and brackets from a long and short side of the pallet.

 **WARNING:** Due to the weight of the cart, two people are required when rolling the cart off the pallet.

4.6.10 ① Position a ramp along the narrow edge of the pallet, then ② use two people to carefully roll the cart off the pallet.

4.6.11 Position the cart near the printer.

 **Stop:** This is the end of the delivery procedure.



# Relocation-Removal

# 5

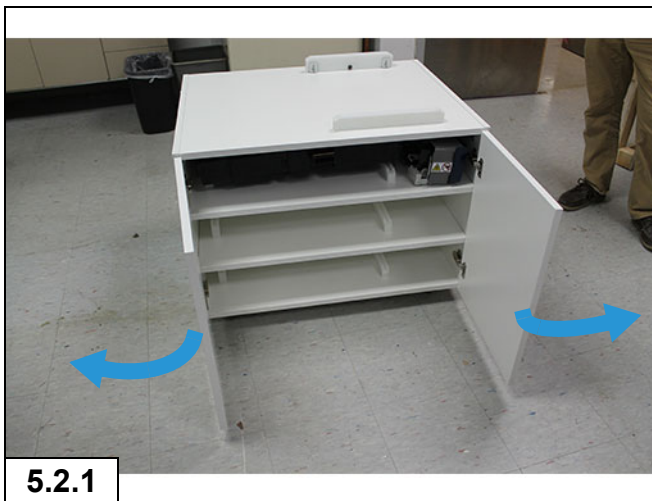
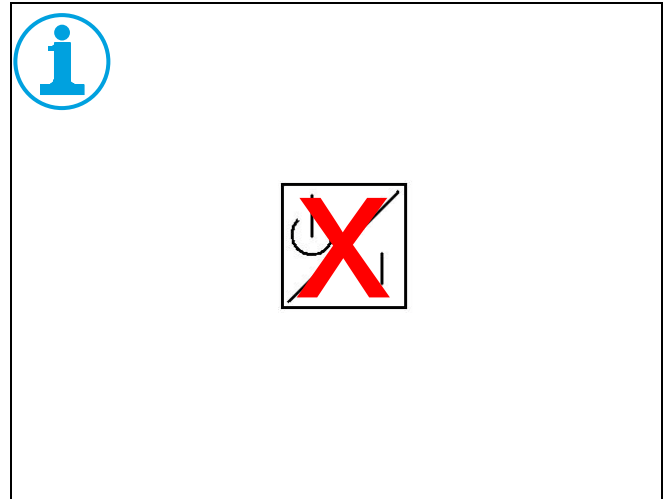
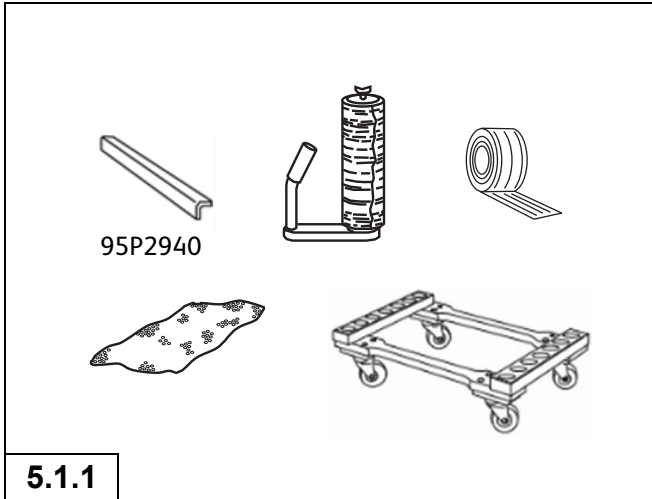

### 5.0.0 Relocation/Removal

#### 5.1.0 Materials Required

5.1.1 Materials required for the move are shown.

#### 5.2.0 Preparing the Xerox® Adaptive CMYK Plus Technology Cart for the Relocation/Return



Note: The cart has no power switch.

5.2.1 Open the front doors of the cart



**CAUTION:** Keep the toner dispenser level while removing and packing.

5.2.2 Carefully remove ① the toner dispenser(s) and ② cartridge(s) housing from the cart.

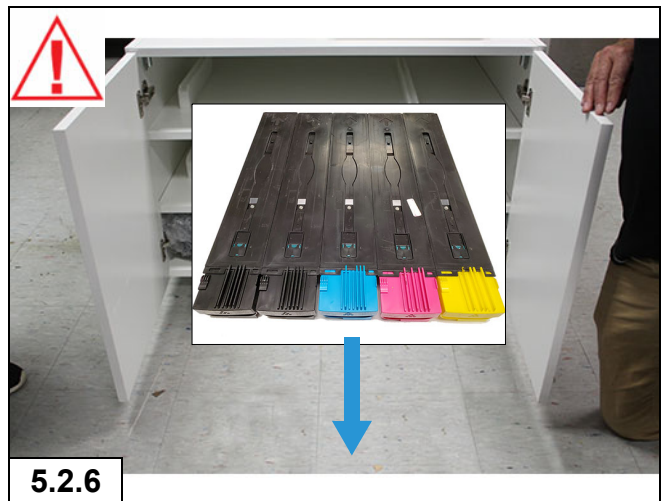
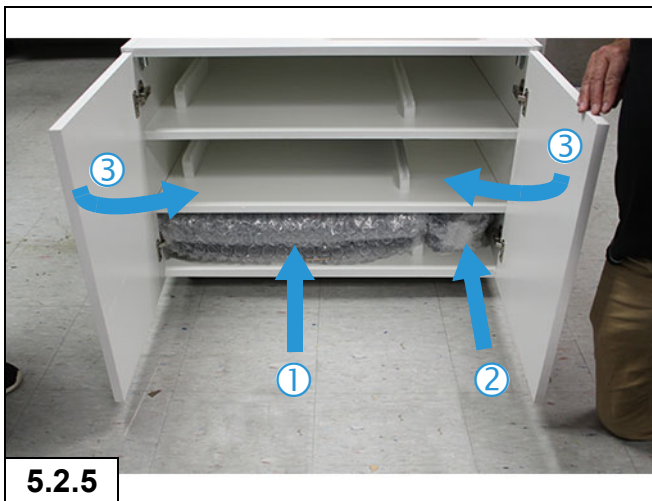
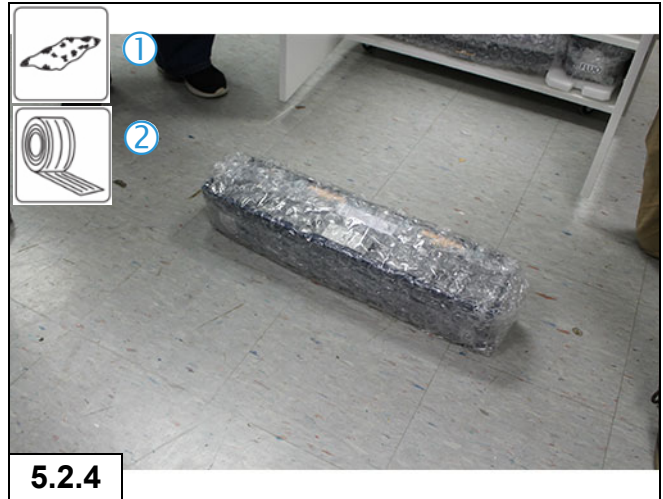

5.2.3 Carefully ① wrap the drum drawer(s) in bubblepack and ② secure with tape.

5.2.4 Carefully ① wrap the dispense housing(s) in bubblepack and ② secure with tape.

5.2.5 ① Return the drum drawer(s) and ② dispense housing bundle(s) to the cart then ③ close the front doors.



**CAUTION: Keep the toner cartridges level while removing and packing.**

5.2.6 Remove any toner cartridges from the cart.

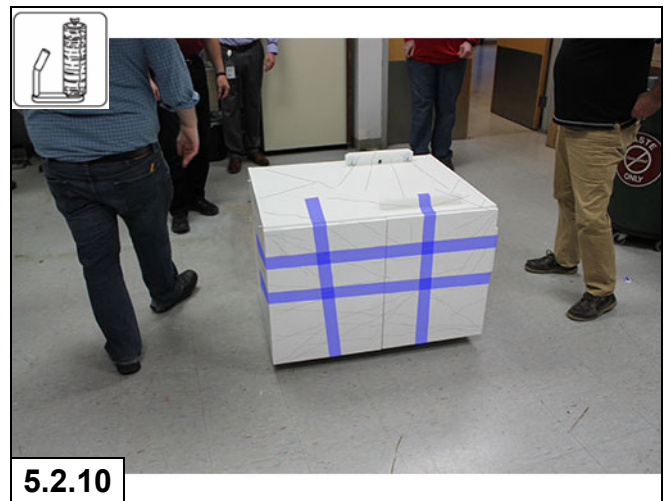
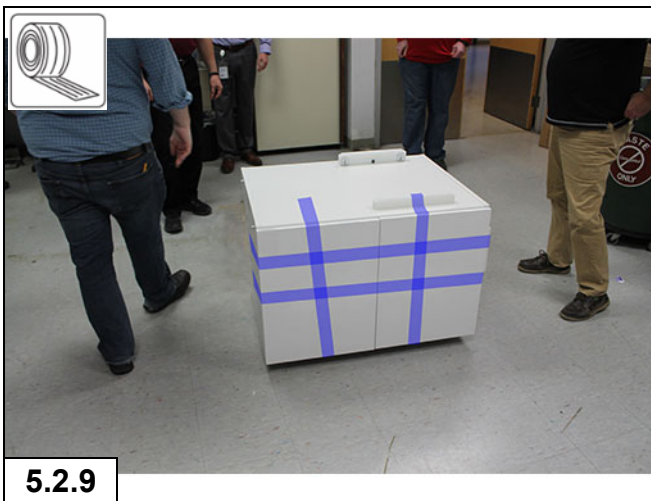



5.2.7 Carefully ① wrap the toner cartridges in bubblepack and ② secure with tape.

5.2.8 Store the wrapped toner cartridges in the cart.

5.2.9 Tape the cart front doors closed.

5.2.10 Wrap the cart with stretchwap.





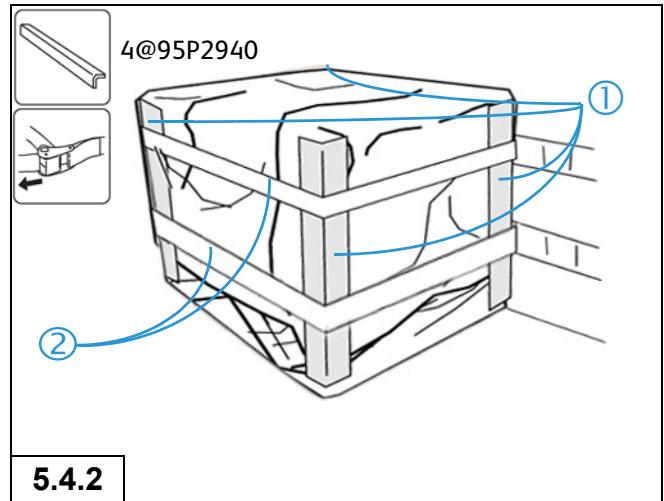
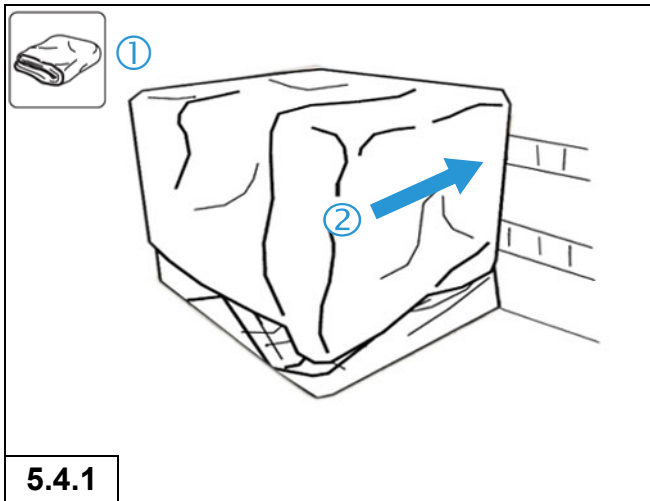
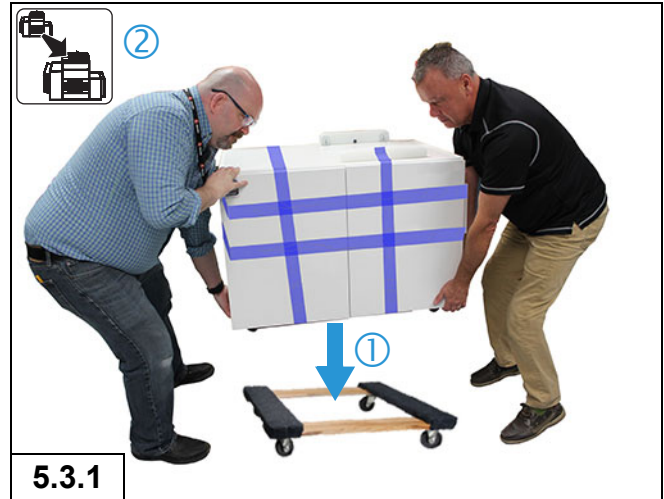

Simple Relocation → Step 5.5.3  
 Complex Relocation → Step 5.3.1



 **Stop:** For Simple Relocations go to Step 5.5.3. For Complex Relocations proceed with Step 5.3.1.

**5.3.0 Complex Relocation**

 **WARNING:** Due to the weight of the cart, two people are required when placing it on a dolly.

5.3.1 ① Using two people place the cart on a four wheel dolly then ② move the cart on the dolly to the truck.

**5.4.0 Moving and Strapping the Xerox® Adaptive CMYK Plus Technology Cart to the Truck (if required)**

5.4.1 Once the cart is on the truck, ① cover with a folded blanket and ② position the cart against the wall of the truck.

5.4.2 ① Position a cornerboard (95P2940) on each corner and ② strap the module into the truck with two straps.



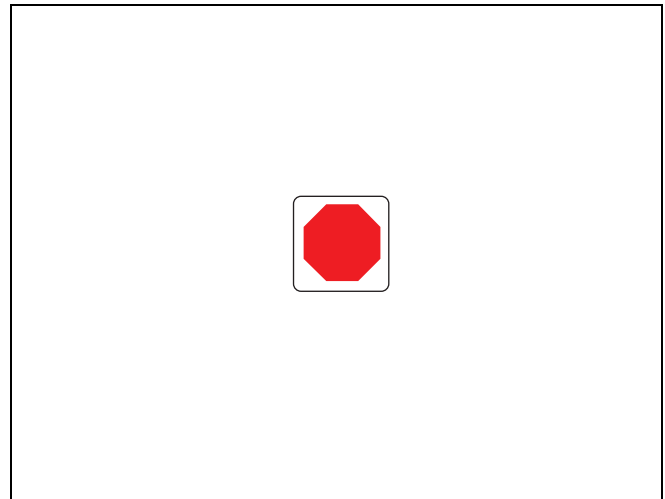
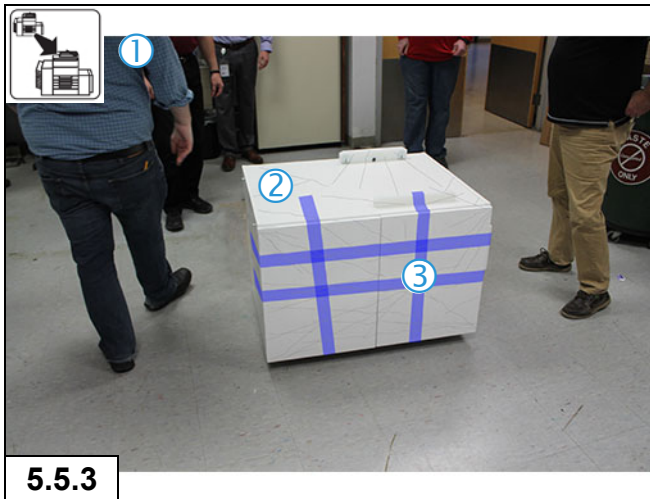
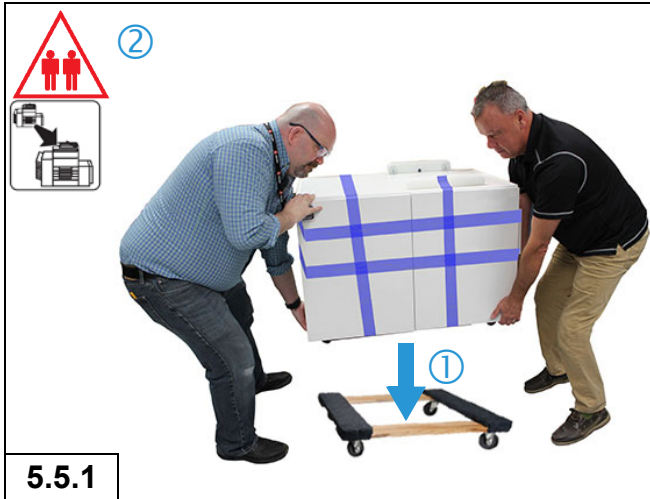

**5.5.0 Position the Xerox® Adaptive CMYK Plus Technology Cart at the New Location**

 **WARNING:** Due to the weight of the cart, two people are required when lifting the cart onto the four wheel dolly.

5.5.1 ① Place the cart on a four wheel dolly and ② carefully roll into the Customer site.

 **WARNING:** Due to the weight of the cart, two people are required when lifting the cart off the four wheel dolly.

5.5.2 Using two people, lift the cart off the dolly.

5.5.3 ① Position the cart next to the printer then ② remove the shrinkwrap and ③ tape.

 **Stop:** This is the end of the relocation procedure.

# Repack-Return

# 6

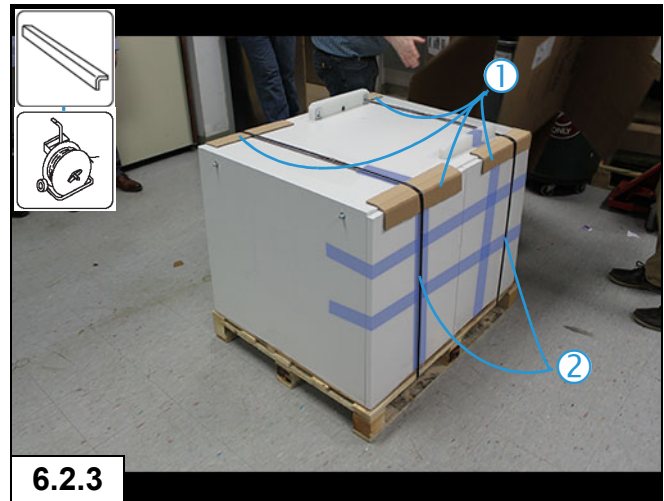
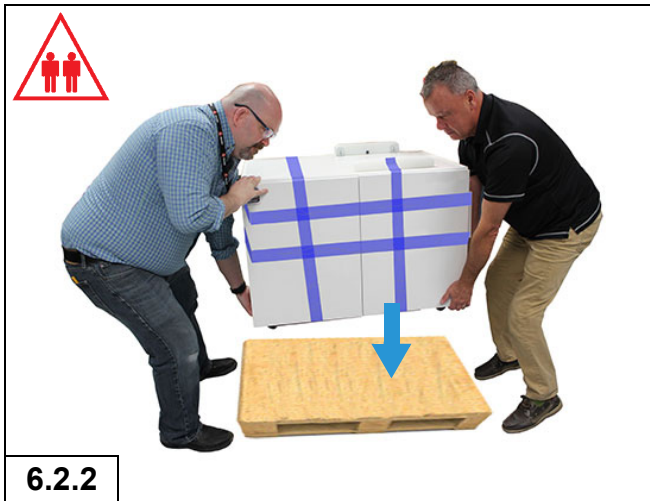
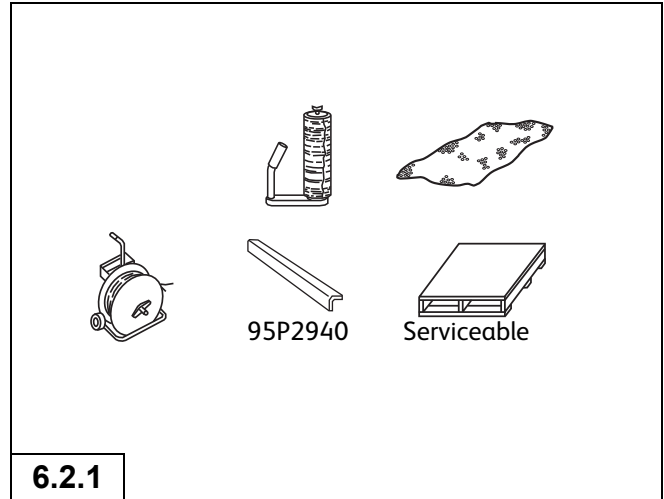
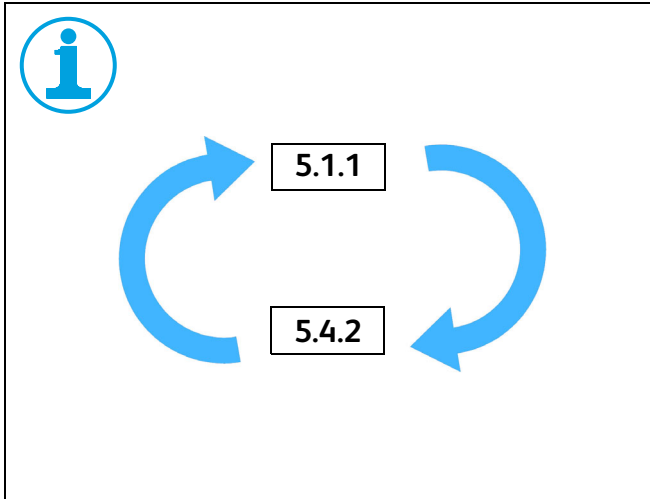

## 6.0.0 Repack and Return

### 6.1.0 Repacking Processes for the Xerox® Adaptive CMYK Plus Technology Cart

 Note: Complete all steps shown in the complex relocation procedure through moving the cart onto the truck.

### 6.2.0 Repacking the Xerox® Adaptive CMYK Plus Technology Cart for Return

6.2.1 Materials required for repacking the system are shown.

 **WARNING:** Due to the weight of the cart, two people are required to lift the cart onto the pallet.

6.2.2 Using two people lift the cart onto a serviceable pallet.

6.2.3 ① Place cornerboards over the top edges of the cart and ② band the cart to the pallet with two bands.

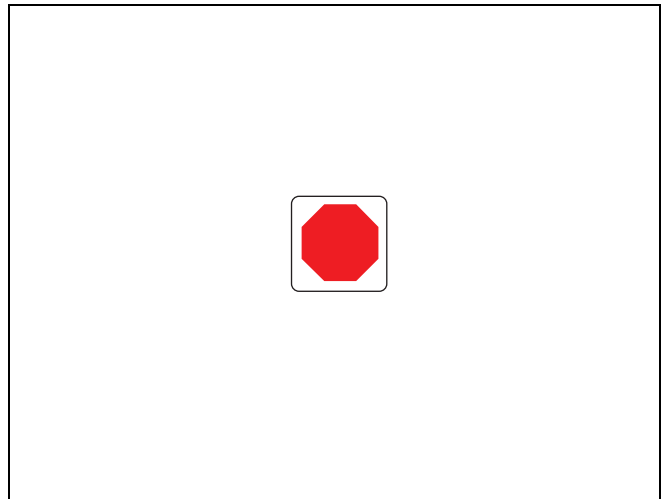
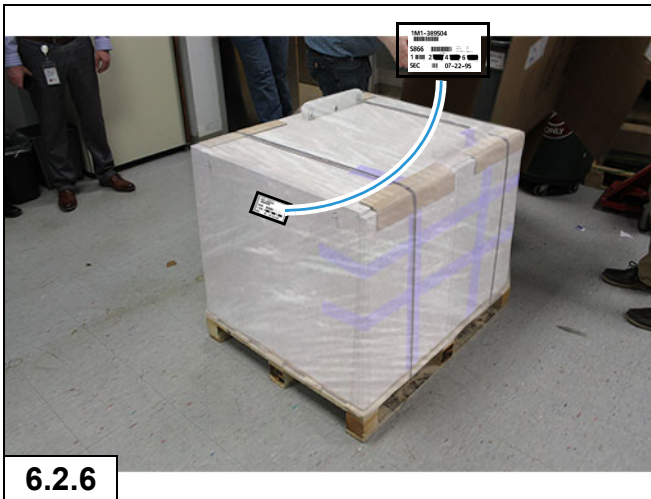
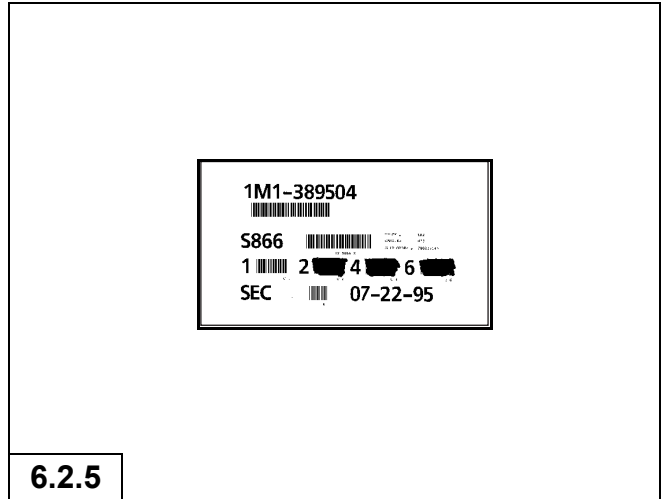

6.2.4 Stretchwrap the cart on the pallet.

6.2.5 Generate the bar code label and cross off all non-applicable codes.

6.2.6 Place the bar code label on the open end of the pallet.



Stop: This is the end of the repack - return procedure.



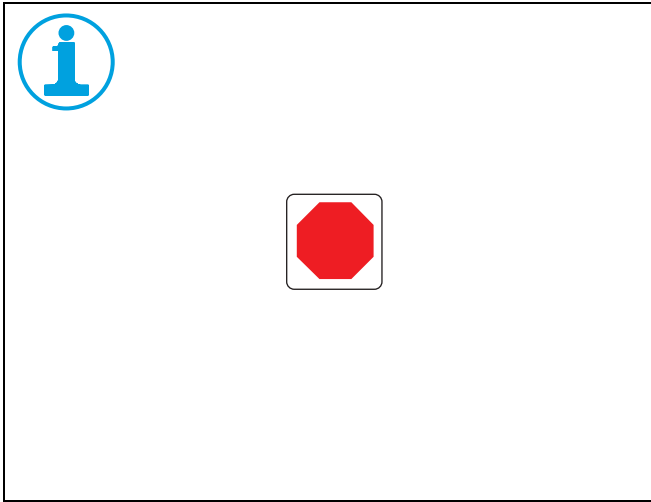

# Accessories

# 7



## 7.0.0 Accessories

 Note: This section does not apply to the Xerox® Adaptive CMYK Plus Technology Cart.

 Stop: This is the end of the procedure.



# Ready-to-Run

# 8

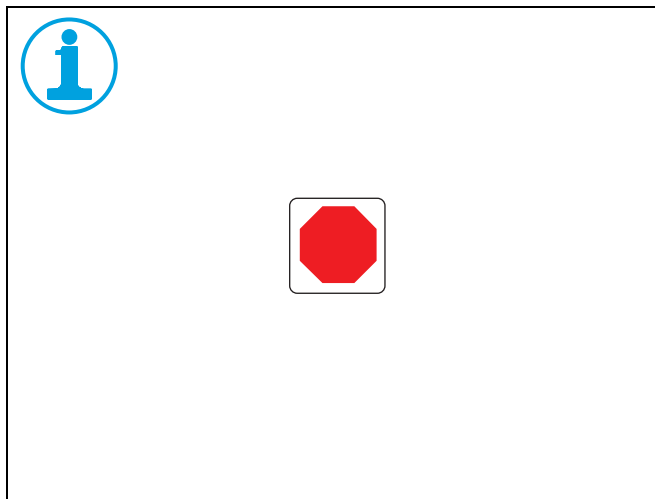

## 8.0.0 Ready to Run



Note: This section does not apply to the Xerox® Adaptive CMYK Plus Technology Cart.



8.0.1 This is the end of the procedure.



# *Block Schematic Diagram (BSD) Training For Xerox Service Personnel and Dealers*

Submitted by:

**Bill Franki**

Genuent, LLC.

595 Blossom Road, Suite 305A

Rochester, NY 14610

Contact: 585-224-4090 x 221 • [bfranki@genuent.com](mailto:bfranki@genuent.com)

October 14, 2019

---

## Executive Summary

The problem addressed by this training solution is Xerox products no longer include directed troubleshooting through the use of Repair Analysis Procedures (RAPs) and other troubleshooting aids that were common to most copiers and printers in the past.

This design document outlines the development and sequencing of content for a cloud based training program for Xerox service technicians and dealers servicing multiple Xerox products including xxxxx, xxxxx, and xxxxx.

The proposed learning solution will be designed to teach and/or refresh basic troubleshooting knowledge and skills using Block Schematic Diagrams (BSD) or documentation requiring a new skill set not possessed by most technicians hired since the late 1990s and some dealer reps. The program would also apply to technicians in need of refresher training on the presenting system and circuit diagnostics in the new Service Guidance System format.

We propose assembling a team consisting of a Service Documentation Specialist with extensive Xerox experience, and an instructional developer / multimedia developer. The team, working with Xerox Program Management and Subject Matter Experts (SMEs) will collaborate to produce the final cloud-based training program.

This design document is based on the information contained in the Block Schematic Diagram Training Statement of Work (SOW) / Requirements Document dated September 2019. Changes in requirements during the course of the project will affect the timeline and cost.

## Performance Objectives

### Terminal Objective

---

Given the BSD Service Training link and a suitable platform, the learner will be able to access the information provided online and, after completing the training modules, answer the questions on the mastery test with a score of 80% or better. The test results will be submitted to Xerox LMS so that learning histories will be properly updated.

### Enabling Objectives

---

Upon completion of the BSD Service Training program, the learner will be able to:

- Describe chain differences
- Describe group functions inside each chain
- Describe the monitoring function through a chain to a specific component

- Explain symbols used in BSD (plug and jack, isolated ground, earth ground vs frame ground)
- Describe signal-naming conventions used in BSDs (High, Low, and Notes)
- Identify how and when Component Control Codes and Fault Codes/Status Codes are used within BSDs
- Describe Power Block information
- Troubleshoot with a BSD to Wirenet and back to a BSD

## Content Outline

The product will be an online training program that will provide a self-paced, independent study learning event for Xerox service technicians and dealers providing service to Xerox products. The training program will be developed and organized into the following sections / modules:

- Module 1: Main Menu / Table of Contents / Pretest
- Module 2: Documentation Symbology and Conventions
- Module 3: Chains
- Module 4: Component Control Codes and Fault Codes / Status Codes usage within BSDs
- Module 5: Power Block Information
- Module 6: Troubleshooting
- Module 7: Mastery Test

## Module Descriptions

### Module 1: Main Menu / Table of Contents / Pretest

**30 minutes**

The learner will initially be presented with the following information:

- Competency Check List
- Option to take the Pretest

If the learner cannot successfully complete the Pretest with the minimally required 80% correct score, they will access the learning modules and resources in the following ways:

- By selecting a module or resource from the table of contents
- By selecting a module or resource from the list of learning prescriptions generated by the pretest

### Module 2: Documentation Symbology and Conventions

**30 minutes**

This module describes and illustrates the various naming conventions and symbols used in the BSDs and will:

- Explain symbols used in BSD (plug and jack, isolated ground, earth ground vs. frame ground)
- Describe signal-naming conventions used in BSDs (high, low, and notes)

There will be a test presented at the conclusion of the module.

---

### **Module 3: Chains**

**45 minutes**

This module presents material related to the BSD Chains. Topics covered in this module are:

- What is a chain / chain differences
- Group functions within a chain
- Following the monitoring function through a chain to a specific component

There will be a test presented at the conclusion of the module.

---

### **Module 4: Component Control, Fault, and Status Code Usage within BSDs**

**45 Minutes**

This module presents and explains how to correctly interpret and use the available component control, fault, and status codes presented by the machine and their diagnostic function within a BSD. Topics covered in this module are:

- What are component control, fault, and status codes
- What differentiates one type of code from another
- How to use various codes to deductively chose an approach to providing a service solution

There will be a test presented at the conclusion of the module.

---

### **Module 5: Power Block Information**

**15 minutes**

This module presents information on the AC and DC electrical diagrams in the BSDs. The module explains how to correctly identify and safely locate the various power lines contained within the machine. The following data will be presented:

- Main power on (AC distribution)
- DC power generation (24, 12, 5 and 3.3 VDC)

There will be a test presented at the conclusion of the module.

---

### **Module 6: Troubleshooting**

**60 minutes**

This critical module demonstrates how to correctly move from a BSD to a Wirenet, or from a Wirenet back to a BSD. Methodology for performing the correct interpretation will be presented for the following activities:

- BSD to Wirenet



- Wirenet to BSD

There will be a test presented at the conclusion of the module.

## Module 7: Mastery Test

**30 minutes**

The Mastery Test will be administered at the end of the learning program. If the requirement of 80% correct is achieved, the results will be logged and transmitted to the Xerox LMS to update the learner's history. If the learner fails to achieve a score of 80% correct, they will be directed to a particular module by failure of a section of the mastery test.

## Development Schedule

The schedule is based on the information contained in the Block Schematic Diagram Training SOW dated September 2019. The schedule could change based on changing requirements.

- 10/28/19 Award of bid and confirmation of billing process via Xerox Purchase Order
- 11/04/19 Begin project – kickoff meetings with Xerox and developers to discuss design elements and confirm objectives (teleconference)
- 10/06/19 Commence development
- 11/11/19 Weekly teleconference review / revision sessions commence
- 02/03/20 Pilot test
- 02/17/20 Final Review
- 02/24/20 Deliver final training program

## Communication and Reporting

Communication with Xerox will be ongoing. An initial expectations meeting with appropriate Xerox personnel will be confirmed at the start of the project to ensure all customer requirements are restated and understood.

At the discretion of the Program Development Team, the cadence of the weekly teleconference meetings can be modified as needed. Module drafts will be uploaded to the Xerox intranet for review as they are developed, independent of the review sessions.

It will be the responsibility of the Xerox Program Manager to identify subject matter experts that can be available for consultation as necessary.

## Testing

An array of test questions will be developed for each competency. The testing will be programmed so that test questions are selected at random for both the pretest and the mastery test. The number of questions required for each competency during the test will be dependent on the complexity of the competency, ensuring that the student has adequate knowledge of the required concepts.

The questions will be presented to the learner in the form of multiple choice or matching.

The pretest is an elective test. Learners who elect to take the pretest and pass it can gain credit for successful completion of a learning module.

If less than 80% of the questions for a specific competency are answered correctly, the learner will be required to review a module or section of a module and take (or retake) the mastery test for that module. A competency checklist page will be available that will list the required competencies and put a check mark next to the ones that have been successfully completed, giving the learner a visual display of progress. The “unchecked” competencies can be selected and the learner will be brought to the appropriate module to review the material and retake the mastery test. The learner will have completed the program when they have answered at least 80% of the questions correctly for all modules (pretest or mastery test), and all competencies are “checked off” on the competency checklist.

## Pilot Testing

Pilot testing will be conducted when the training is completed. The Xerox Program Team and SMEs will review materials as they are developed and will take part in, or determine who will take part in the pilot tests. The learners for the pilot test may also be taken from the CSE population.

## Program Presentation Treatment

The program will be developed in a style consistent with, and level of complexity similar to, the sample Xerox xxxx / xxxx Production Printing System provided with the BSD Training SOW.

Our expectation is to provide the learner with an interactive experience. The program will utilize animated zooms, wipes, along with movement of various graphics or photos. Appropriate audio cues will also be implemented throughout the program to help maintain an active level of interest and attention by the learner.

**Block Schematic Diagram  
Learning Resource CD  
Course Map Diagram**

**Learning Resources  
Links**

- Describe the training material, objectives, and resources in the program environment.

**Search Menu**

- Locate information to access a specific function.

**Block Schematic Diagram Service /  
Dealer Training Program**

- Module 1 Main Menu / Table of Contents / Pretest
- Module 2 Documentation Symbology and Conventions
- Module 3 Chains
- Module 4 Component Control Codes and Fault Codes / Status Codes usage within BSDs
- Module 5 Power Block Information
- Module 6 Troubleshooting
- Module 7 Mastery Test.

**Module 1: Main Menu / Table of Contents /  
Pretest**

- Competency Check List
- Option to take the Pretest.

Module Access:

- By selecting a module or resource from the table of contents
- By selecting a module or resource from the list of learning prescriptions generated by the pretest.

**Module 4: Component Control Codes and  
Fault Codes / Status Codes usage within  
BSDs**

- What are component control, fault, and status codes
- What differentiates one type of code from another
- How to use various codes to deductively chose an approach to providing a service solution.

**Module 2: Documentation Symbology and  
Conventions**

- Explain symbols used in BSD (plug and jack, isolated ground, earth ground vs. frame ground)
- Describe signal-naming conventions used in BSDs (high, low, and notes).

**Module 5: Power Block Information**

- Main power on (AC distribution)
- DC power generation (24, 12, 5 and 3.3 VDC).

**Module 3: Chains**

- What is a chain / chain differences
- Group functions within a chain
- Following the monitoring function through a chain to a specific component.

**Module 6: Troubleshooting**

- BSD to Wirenet
- Wirenet to BSD.

**Module 7: Mastery Test**



## Online Samples

Note: Presentations (noted below) will not render (stream) properly from the Google Slides environment and should be downloaded to view.

**Xerox iPage** (design, development, implementation, maintenance, and multiple authoring contributions.)

[https://drive.google.com/file/d/0B9Tc6Y2V1NxZaEhCekJPSEnuSXc/view?pref=2&pli=1&resourcekey=0-B9II0vTx5mcrcRA\\_HnJNYQ](https://drive.google.com/file/d/0B9Tc6Y2V1NxZaEhCekJPSEnuSXc/view?pref=2&pli=1&resourcekey=0-B9II0vTx5mcrcRA_HnJNYQ)

**Xerox Equipment Identification Handbook** (this is a deliverable composed of highly customized MS Access reports. In addition to driving the printed publication, the source file is an Access database available to users for search and reporting requirements.)

[https://drive.google.com/file/d/151DO\\_ftnBIF8J8hIFt3EzBGumIWKuUtE/view](https://drive.google.com/file/d/151DO_ftnBIF8J8hIFt3EzBGumIWKuUtE/view)

Download to view:

**eHealth Technologies Intelligent Health Record Aggregation Platform Referral Management Solution - Orientation Presentation** (presentation design/creation, graphics/animation creation, video editing, script writing, audio editing, final optimized rendering, and publication.)

[https://drive.google.com/file/d/1-BB4XcdwHD5pB2eKGUR5kr\\_BomB8XhOv/view?usp=sharing](https://drive.google.com/file/d/1-BB4XcdwHD5pB2eKGUR5kr_BomB8XhOv/view?usp=sharing)

Download to view:

**Schedule an AWS Certification Exam Using an Xvoucher Instructional Presentation**

(presentation design/creation, graphics/animation creation, video editing, script writing, voiceover, audio editing, final optimized rendering, and publication.)

[https://drive.google.com/file/d/1LLi5mE8ucVldwWF7JtorrL-WQ\\_bL79IU/view?usp=sharing](https://drive.google.com/file/d/1LLi5mE8ucVldwWF7JtorrL-WQ_bL79IU/view?usp=sharing)

Download to view:

**Select, Self-Assign, and Register for Online Training via SuccessFactors Instructional Presentation**

(presentation design/creation, graphics/animation creation, video editing, script writing, voiceover, audio editing, final optimized rendering, and publication.)

<https://drive.google.com/file/d/1b3ybhg9TVFVSygoZJSyVVtWPNQcdXmoM/view?usp=sharing>

**Xerox Adaptive CMYK Plus Technology Service Product Orientation Video Program** (video capture, graphics/animation creation, video editing, script writing, audio editing, final optimized rendering, and publication.)

[https://drive.google.com/file/d/1W6te3K\\_DoTEZL0aJ6ifKzCXayeSdgdDn/view?usp=sharing](https://drive.google.com/file/d/1W6te3K_DoTEZL0aJ6ifKzCXayeSdgdDn/view?usp=sharing)

**Xerox PrimeLink B91xx Series Differences from D-Series Product Orientation Video Program**

(video capture, graphics/animation creation, video editing, script writing, voiceover, audio editing, final optimized rendering, and publication.)

<https://drive.google.com/file/d/1yAyWk52mG7EhHgMGDSzidUdwmUxz3s5N/view>

**Xerox Adaptive CMYK+ Toner Swap Instructional Video Program** (video capture/editing, script writing, audio editing, final optimized rendering, and publication.)

[https://www.youtube.com/watch?v=hg9X\\_5f2zEO](https://www.youtube.com/watch?v=hg9X_5f2zEO)

**Original Electronic Music** (composition, performance, arrangement, final mix.)

<https://youtu.be/Mmv6b5yyj7A?si=Qox9OpLQ5UYdv8ln>