

---

## Introduction

FSR is a leading manufacturer of a wide variety of infrastructure solution products for the audio/video, Information and Communications Technologies (ICT) for education, enterprise, hospitality, and government markets. Their products include floor, wall, table, and ceiling connectivity boxes, as well as a full line of interfaces, distribution amplifiers, matrix switchers, seamless switchers and HDBaseT & CAT-X signal delivery solutions.

With the ever-changing world of ICT technology, FSR is constantly addressing unique environments, including intelligent buildings. Today many previous disparate applications are now being connected to the IP network and requiring connectivity and processing at the edge, closer to the device. Standards and building designers are recommending a zone cabling layout which provides a consolidation point that is plenum-rated to be located in the ceiling while providing added flexibility and security to the infrastructure. This has opened up the doors for cable management manufacturers, such as FSR, to provide secure housings for active and passive components in the digital ceilings.

FSR is taking a close look at the existing products available on the market today and will be engineering their product line to align with the current and future requirements of cabling and component connectivity for applications such as wireless access points, LED lighting, security cameras, sensors and AV products such as digital displays and projectors.

## FSR CORE offerings

FSR currently offers three (3) separate designs of ceiling enclosures as part of their CORE (Cool Overhead Rack Enclosure) Series, which was developed for AV installations to provide mounting space in the ceiling. This allows AV equipment to be separated from the room space while adding a level of security, not found in floor and wall racks. These boxes mount above a stand drop ceiling grid and are available in three sizes and models. All have the capacity to hold two (2) half-rack devices and up to four (4) full-width rack devices. The three “models” and features are as follows:

**CB-12** – a 2' x 1' enclosure with an external AC receptacle to the ceiling surface and four (two duplex) additional un-switched AC receptacles inside the enclosure, two shelves to mount two half-rack devices for AV equipment and knockouts to allow cabling and wiring. An optional fan kit is available. The CB-12P includes a projector pole mount to hand up to a 50-lb projector. An optional UL-Listed 1449 “Type 1 Surge Protective Device” can be added.

- Dimensions: 23.69” x 11.69” x 6” D
- Construction: Steel, Metal
- Ratings: Plenum Rated: Conforms to UL 2043: UL Standard for Safety Fire Test for Heat and Visible smoke for Discrete Products and their Accessories installed in Air Handling spaces. Safety Rated: Conforms to UL 60950-1: Information Technology Equipment – Safety and certified to CSA 22.2 60950-1 Safety of Information Technology Equipment



FSR CB-12

**CB-22** - This 2'x2' enclosure can accommodate two (2) full rack pieces of equipment or four (4) half-rack pieces on the built-in shelves. The unit includes an external AC receptacle and a switch/circuit breaker on the ceiling surface, and five AC outlets spaced to allow room for wall warts inside the enclosure. A white rim door inserts into a ceiling tile into for a matching look. The CB-22P includes a projector pole mount. The CB-22S and CB-22SP are the first "smart" ceiling boxes with "Smart Sense" technology that detects the power state of the projector and uses the projector's power state to turn the switched outlets on or off. The CB-22SP has a "Smart Control Module" that provides a built-in real time clock with scheduling software to automatically turn on or off the switched receptacles on a set schedule to eliminate wasted power including that of the projector.

- Dimensions: 23.69" x 23.69" x 6" D
- Construction: Steel/Metal
- Ratings: Plenum Rated: Conforms to UL 2043: UL Standard for Safety Fire Test for Heat and Visible smoke for Discrete Products and their Accessories installed in Air Handling spaces. Safety Rated: Conforms to UL 60950-1: Information Technology Equipment – Safety and certified to CSA 22.2 60950-1 Safety of Information Technology Equipment



**FSR CB-22**

**CB-224** – The CB-224 series is a 2' x 2' high capacity ceiling box designed to fit into a standard 2' x 2' or 2' x 4' drop ceiling. Available in 4 versions, non-pole mount and pole mount, both with or without "smart" electronics, this model was designed to include a deeper design to accommodate applications requiring more internal equipment than the CB-12 and CB-22 models. Designed to fit its capacity to support 50 pounds for a projector, and 12 pounds on each shelf allows it to become a robust ceiling mount. The product's advanced deep box design has a pull-down 4 RU cage with gas-spring assisted ball-bearing slide. 2 RU of angle-adjustable rack-mounting surfaces on either end of the cage facilitate mounting and visibility of 1RU/2RU patch panels. The CB-224 has six (6) AC outlets in the box and one (1) in the room. A master power switch is accessible from the room. The 'P' option adds an adapter for projector pole mounting. This allows cabling to pass from inside the ceiling box, down the pole and to the projector. The 'S' option adds cooling fans and the "Smart Power" module. This module allows the power in the box to be either remotely controlled or switched based on the current draw of specific outlets. In this energy-savings mode, the power in the box is switched on and off automatically with the projector to conserve power. The CB-224RKRL optional rack rail hardware kit adds two (2) additional rack spaces at the rear of the CB-224 cage for cable management and mounting of accessories.



**FSR CB-224**



The product's advanced deep box design has a pull-down 4 RU cage with gas-spring assisted ball-bearing slide. 2 RU of angle-adjustable rack-mounting surfaces on either end of the cage facilitate mounting and visibility of 1RU/2RU patch panels. The CB-224 has six (6) AC outlets in the box and one (1) in the room. A master power switch is accessible from the room. The 'P' option adds an adapter for projector pole mounting. This allows cabling to pass from inside the ceiling box, down the pole and to the projector. The 'S' option adds cooling fans and the "Smart Power" module. This module allows the power in the box to be either remotely controlled or switched based on the current draw of specific outlets. In this energy-savings mode, the power in the box is switched on and off automatically with the projector to conserve power. The CB-224RKRL optional rack rail hardware kit adds two (2) additional rack spaces at the rear of the CB-224 cage for cable management and mounting of accessories.

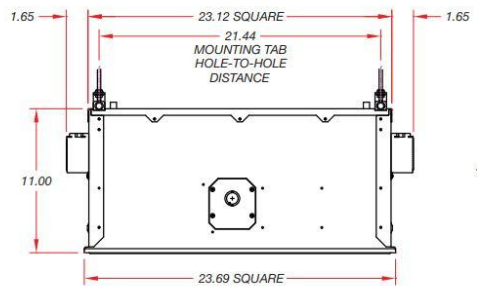

**FSR CB-224**

The equipment and patching can be mounted on the door, which opens for easy access, but care must be taken for the cables' bend radius.

- Dimensions: 23.69" x 11.69" x 11.00" D
- Construction: Steel, Metal

The

- Ratings: Plenum Rated: Conforms to UL 2043: UL Standard for Safety Fire Test for Heat and Visible smoke for Discrete Products and their Accessories installed in Air Handling spaces. Safety Rated: Conforms to UL 60950-1: Information Technology Equipment – Safety and certified to CSA 22.2 60950-1 Safety of Information Technology Equipment

## Other Market Offerings:

### Hubbell

Hubbell Premise's product line includes ceiling enclosures for AV and for zone cabling layouts and can accommodate either passive components or active and passive:

**AVCE1P:** This 2'x1' unit is designed specifically to house active AV devices to integrate AV distribution, data connections and power in one location, providing a direct connection to a projector or a display device. The enclosure comes loaded with two (2) Hubbell 20A duplex receptacles and a 2-gang Raco box. An additional AV data kit is available. It does not have a mount for a projector, but holds the AV equipment for the adjoining projector, as well as the AC connectivity. Specifications include:

- Dimensions: 24" x 12" x 8D", Thickness 0.5"
- Construction: Steel, Cold Rolled, white powder coat
- Ratings: Plenum, UL 1863 and 2043 Listed
- More information: <https://www.hubbell.com/hubbellpremisewiring/en/Products/Data-Communications/Racks-and-Enclosures/Wall-Mount-Cabinets/WallCeiling/AVCE1P/p/1743877>



Hubbell's ZOBOX® Ceiling Boxes are supplied fully assembled in two different styles for zone enclosures as consolidation points. One style is suitable for patch panels -- ZCB5UP (passive), while the other is suitable for both passive and active equipment -- ZCB7UA. A ventilation fan is included with ZCB7UA, where active equipment will be used. The design of the Hubbell ceiling boxes are similar to FSR with on-the-door mounting for the equipment and cables.

**ZCB5UP:** Remote 2' x 2' telecom enclosure for mini backbone or consolidation point cross connections (passive only), can hold five (5) rack units (RUs) with a maximum of 120 ports. Houses 24- and 48-port patch panels in a 19" rack

- Dimensions: 21.5" x 21.5" x 12.75", Thickness 0.060"
- Construction: Aluminum
- Listings: UL Listed Plenum Rated EIA/ECA-310-E Universal Mounting Pattern
- More Information: <https://www.hubbell.com/hubbellpremisewiring/en/Products/Electrical-Electronic/Boxes/Ceiling-Boxes-Covers/ZCB5UP/p/1743871>

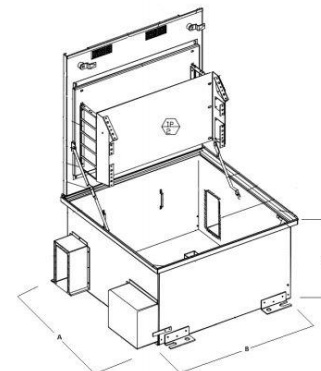

**ZCB7UA:** 2' x 2' Active Ceiling Box, Same dimensions as the ZCB5UP but can hold 7 RU – 5 RU for passive 120-ports plus 2U for active equipment. Houses 24 and 48-port patch panels in a 19" rack

- Dimensions, Construction & Listings (same as ZCB5UP)
- More Information: <https://www.hubbell.com/hubbellpremisewiring/en/Products/Electrical-Electronic/Boxes/Ceiling-Boxes-Covers/ZCB7UA/p/1743872>

## Panduit

Panduit does not manufacture specific ceiling boxes for AV. The PanZone® In-Ceiling Enclosures are used as mini-telecommunication rooms to mount network equipment in the air handling space above a drop ceiling. Panduit offers two zone enclosures – one for passive (PZICEE) and one for active equipment (PZICEAE). Also, the Panduit zone boxes mount the equipment on the door hinge for easier access for moves, adds and changes.

**PZICEE:** The PZICEE is designed to accommodate passive network equipment including high-density applications and can accommodate 8 RU of patch panels (either 110 punchdown blocks or standard 19" patch panels). This passive enclosure can be converted to a 220V active enclosure with a Shuko style plug for use in Europe with the installation of optional fan kit, PZICFK-E.

- Dimensions: 23.50" H x 23.50" W x 13.43" D
- Construction: Steel, White
- Ratings: UL 2043 plenum-rated and UL 1863 rated

**PZICEAE:** Includes all PZICEE components plus a cooling fan and air deflector for ventilation. Accommodates 2 RU of active equipment and up to 6 RU of room for passive network equipment including 110 blocks or TIA/EIA 19" patch panels. Thermal management optimizes airflow for improved heat dissipation system of higher heat load network equipment. The active in-ceiling enclosure is designed to accommodate equipment enabling a "Fiber to the Zone" (FTTZ) network infrastructure topology. The thermal management system within the enclosure supports high heat load applications including PoE enabled network switches and uninterruptible power supplies (UPS). The enclosure includes a two-tiered TIA/EIA 19" mounting bracket with integrated horizontal slack manager to provide an all-in-one cable management solution for performing front accessible moves, adds, and changes.

- Dimensions & Construction & Listings (same as PZICEE)
- More Information: <https://www.panduit.com/content/dam/panduit/en/products/media/4/34/234/4234/100244234.pdf>



Panduit PZICEE

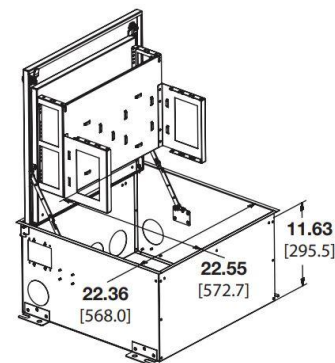

Panduit PZICEAE



## Legrand (Wiremold and Middle Atlantic)

Legrand offers AV solutions as well as integrated zone enclosures for networking. The AV solutions are called “Evolution” Series (under the Wiremold and Middle Atlantic product lines) and the zone enclosures (both active and passive) are called the CZE Series (under Legrand’s Data, Power and Control Division).



Evolution Ceiling Boxes

**Evolution:** Evolution Series Ceiling Boxes are available in six (6) different versions from a basic model to the RackLink™ version where the product can monitor and connect with building automation systems. Evolution Series Ceiling Boxes are designed to easily accept a standard 1RU or a 2RU unit, allowing the box to adapt to the specific application requirements.



The ECB2S-CR, ECB2SP-CR, ECB2S-RLNK, and ECB2S-RLNK are equipped with a thermostatically controlled AC fan to keep the A/V equipment cool while keeping the environment quiet. The ECB2S-CR and ECB2SP-CR are equipped with four (4) controlled receptacles allowing for the devices that are plugged into those receptacles to be automatically turned off when not in use, saving component life and increasing energy savings for the building. The storage shelf is removable to allow A/V equipment to be mounted outside the box, facilitating a quicker, easier installation. The storage shelves inside the Evolution Series Ceiling Box rotate allowing quick and easy access to service and maintain both the front and back of the AV equipment without having to remove from the box.

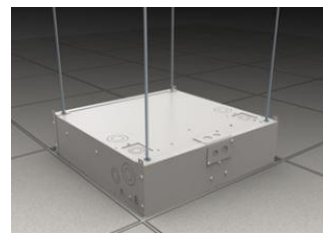

- Ratings: Plenum Rated in accordance with section 300.22(c) of the National Electrical Code. n ETL Listed. Approved for use in the United States and Canada. Conforms to UL 60940-1 and CSA 22.2 60950-1 Information Technology Equipment standards.
- More information:

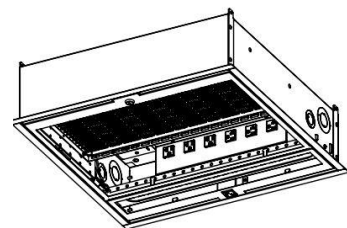

<https://www.legrand.us/wiremold/wall-ceiling-boxes/evolution-series-ceiling-box/ecb2s-evolution-series-ceiling-box.aspx>

Evolution Series Ceiling Box Model Selection Guide						
EVOLUTION CEILING BOX MODEL	ECB2S	ECB2SP	ECB2S-CR	ECB2SP-CR	ECB2S-RLNK	ECB2SP-RLNK
BOX SIZE:	23 3/4" x 23 3/4" x 6 3/4" [603mm x 603mm x 171mm]					
INSTALL TYPE:						
False Ceiling	YES	YES	YES	YES	YES	YES
Hard Ceiling	YES	YES	YES	YES	YES	YES
SHELF CAPACITY:	2RU	2RU	2RU	2RU	2RU	2RU
RECEPTACLES:	6	7	4 Controlled, 2 Uncontrolled	4 Controlled, 3 Uncontrolled	4 Controlled, 2 Uncontrolled	4 Controlled, 3 Uncontrolled
REMOVABLE SHELVES:	YES	YES	YES	YES	YES	YES
PROJECTOR MOUNT:	No	Yes, Up to 50 lbs.	No	Yes, Up to 50 lbs.	No	Yes, Up to 50 lbs.
COVER COLORS:	White	White	White	White	White	White
KO SIZE RANGE: (Trade Size)	1/2" to 2"	1/2" to 2"	1/2" to 2"	1/2" to 2"	1/2" to 2"	1/2" to 2"
NOTES:	Trim flange and decorative cover are paintable					

## CZE Series of Ceiling Enclosures

Legrand offers the CZE (Ceiling Zone Enclosure) Series to support integrated zone systems to create an intermediate or remote consolidation point for voice and data outlets. All are 2' x 2' size to integrate into standard drop ceiling grids.

**CZE-242412PP:** Passive enclosure for mounting patch panels – 12" deep patch panel enclosure. One bracket for 19" patch panels which supports 5 RU.

**CZE-242412WB:** Ceiling zone enclosure with wiring blocks – 12" deep termination block enclosure with one removable mounting plate for two 300-pair 1100 style termination blocks (without legs).

**CZE-242412A:** Enclosure for active equipment – 12" deep telecommunications enclosure with one removable 7 RU bracket for 19" patch panels and equipment. Includes junction box and fan.

- Ratings: UL Listed. File E145222, Guide DUXR. Meets Article 800 of NEC and Article 60-308 of CEC.
- For more information:  
<https://www.legrand.us/wiremold/wireless-zone-enclosures/zone-cabling-enclosures/cze-series-ceiling-enclosures.aspx>  
and  
<https://www.legrand.us/wiremold/wireless-zone-enclosures/zone-cabling-enclosures/cze-series-ceiling-enclosures/cze-children/cze-242412a-ceiling-zone-cabling-enclosure-for-active-equipment.aspx>



Legrand CZE-242412 PP

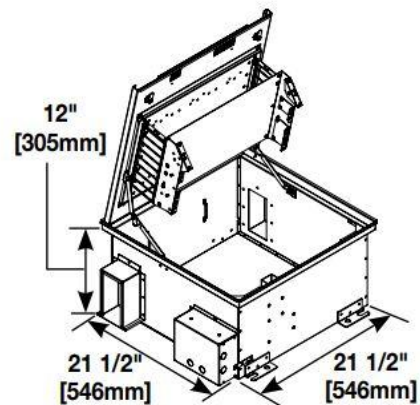

Legrand CZE-242412 A

## Leviton

Leviton does not offer an AV ceiling boxes but offers telecommunications enclosures – three different styles – one for passive and two different sizes for active equipment.

**Z1000-PC2:** This 2' x 2' enclosure houses one removable 19-inch rack-mount assembly with a total of 5RU. Comes with two edge-protected cable access ports with fire-rated foam sealing (polychloroprene compound) kits. This enclosure has fully-hinged drop-down doors and installs flush with the drop ceiling.

- Dimensions: 22" x 22" x 12"
- Construction: Sheet Aluminum
- UL Listed (Plenum)
- For more information:  
[https://www.leviton.com/en/docs/Leviton\\_Z1000-PC2\\_Passive\\_Ceiling-Mount\\_Telecommunications\\_Enclosure.pdf](https://www.leviton.com/en/docs/Leviton_Z1000-PC2_Passive_Ceiling-Mount_Telecommunications_Enclosure.pdf)

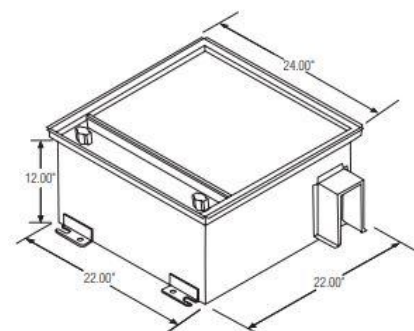

Leviton Z1000-PC2

**Z1000-AC2 & Z1000-AC4:** These ceiling-mount telecommunications enclosures for passive and active devices mount in standard drop ceilings and are available in two sizes to suit various installations. Enclosures accommodate removable 19-inch rackmount assemblies designed to support active equipment, patch panels, and wire management in zone cabling applications. Edge-protected, cable access ports with fire-rated foam sealing kits for use in plenum spaces are standard. Enclosures are AC power ready with 9 CFM fan for heat removal. Fully-hinged, drop-down doors support installed equipment. Enclosure installs flush with the drop ceiling. Equipment is mounted on the doors.

- Z1000-AC2: 2' x 2' enclosure houses one removable rackmount assembly with 2RU active, 5RU (2U+1U+2U) of patch panels and wire management
- Z1000-AC4: 2' x 4' enclosure houses two removable rackmount assemblies, each with 4RU active (8U total), 10RU divided (2U+1U+2U) of patch panels and wire management
- Construction: 06" sheet aluminum with riveted construction. Foam sealing kit is a polychloroprene compound.
- UL Listed (Plenum rated)
- For more information: [https://www.leviton.com/en/docs/Leviton\\_Z1000-AC2\\_Z1000-AC4\\_Active\\_Ceiling-Mount\\_Telecommunications\\_Enclosures.pdf](https://www.leviton.com/en/docs/Leviton_Z1000-AC2_Z1000-AC4_Active_Ceiling-Mount_Telecommunications_Enclosures.pdf)



## Siemon

Siemon does not have enclosures for AV and offers one style of zone enclosure to support passive patch panels in a zone cabling layout for a variety of enterprise workspaces focusing on enabling shorter easy-to-manage connections directly to building devices such as LED lights, security cameras, wireless access points or building automation controllers, or to outlets serving voice, data or other systems. Siemon's zone enclosure installs flush within a 2' X 2' ft. drop ceiling tile space offering a 4U adjustable rack system tilts 45 degrees, with a recommended maximum 96-port count for copper cabling. Hinged door with foam gasket to minimize vibration. Includes knockouts and cable bushings. Available with lock or thumbblatch. Has vents for airflow and heat dissipation.

Siemon's zone enclosure does not allow the equipment to be mounted on the door

- Dimensions: 2' x 2' x 10.125" depth
- Construction: 15 AWG Aluminum (Door is 16 AWG) Material Compliance RoHS, Lead free, Halogen free, PVC free Finish Textured powder coat
- Standards Compliance: EIA/ECA-310-E UL 1863 Meets UL 2014 Plenum Requirements
- For more information: [https://ww2.siemon.com/e-catalog/ECAT\\_GI\\_page.aspx?GI\\_ID=rcm\\_passive-ceiling-zone-enclosure](https://ww2.siemon.com/e-catalog/ECAT_GI_page.aspx?GI_ID=rcm_passive-ceiling-zone-enclosure)

### Siemon Zone Enclosure



## Chatsworth (CPI)

Chatsworth Ceiling Systems are designed for zone and wireless enclosures that are used above a drop ceiling replacing a single 2 x 2 or 2 x 4 drop ceiling tile and have an access door that provides easy access to equipment as it mounts on the door. There are four different models for passive and four different models for both passive and active:

### Passive Enclosures:

- A1222-PP: (2'x2') Provides a total of 5U with three brackets sized 2U-1U-2U
- 13812-002: (2'x2') Provides larger cable openings for Cat 6A; one 3-1/4"x 14-3/4" and one 6-1/4" x 6-7/8"
- A1024-PP: (2' x 4') Provides a total of 5U with 3 door brackets sized 2U-1U-2U
- A1224-PP: (2' x 4') Provides a total of 10U with 3 brackets sized 4U-2U-4U which may be mounted on the door or the back of the enclosure

### Active Enclosures:

- A1222-HR: (2'x2') Provides a total of 5U for patch panels and 2U x 15"D for active equipment (which mounts on the door)
- 13812-001: (2'x2') Provides larger cable openings for Cat 6A; one 3-1/4"x 14-3/4" and one 6-1/4" x 6-7/8"
- A1024-HR: (2' x 4') Provides a total of 5U for patch panels and 2U x 15"D for active equipment which mounts on the door
- A1224-HR: (2' x 4') Provides a total of 10U with 3 brackets sized 4U-2U-4U to support a combination of patch panels and 15"D or less for active equipment; brackets may be mounted on the door or the back of the enclosure. The enclosure includes a junction box for a single duplex power outlet and a filtered fan to remove heat from the enclosure (air is drawn from and expelled to the office space (not the plenum))

### Additional information

- Exact dimensions not provided on website or specifications documents
- Construction: .060" thick sheet aluminum, riveted construction. Includes foam sealing kit: polychloroprene latex compound
- Listing: UL Listed 1863; UL 50; UL 2043
- For more information: <https://www.chatsworth.com/en-us/products/cabinets-enclosures-containment/telecommunications-enclosures/drop-ceiling/ceiling-enclosure-for-hubs-switches-and-patch-pane#stickysectionid>



Chatsworth A1222-PP



Chatsworth A1024-PP

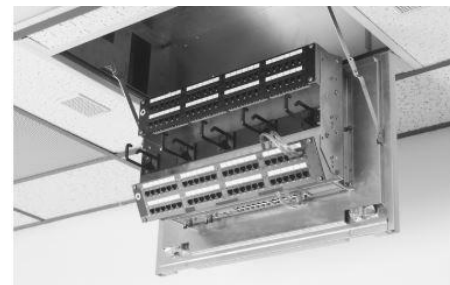

Chatsworth A1024-PP



Chatsworth 1222-HR



## Snake Tray

Snake Tray offers fully assembled ceiling mounts for passive fiber consolidation enclosure in different sizes -- 2' x 2', 2' x 4' and 2' x 6' drop ceilings. Features include: one (1) Leviton 288 pair block with C4 clips; one test patch cord, 110 to RJ45; fiber mounting plate for two (2) MPO cassettes; third cassette shelf available; removable latch door with two (2) keyed locks; and sixteen (16) trade size EKO's with #4404 Arlington snap-in grommets.

- Dimensions: Exact dimensions not found
- Construction: 16 gauge galvanized steel with Nortek#P7RW124 White Peel powder Coat Finish (other colors are available upon request)
- No UL standards are listed
- For more information:  
<http://www.snaketray.com/accessories/basic-2-x-2-box-empty/>

SnakeTray Ceiling Mount



## HellermanTyton (UK)

The lockable zone enclosure from HellermanTyton was designed for data centers where raised floors or suspended ceilings provide suitable hosting space away from the rack space. The zone cabling enclosure from HellermannTyton provides up to 2U of patching space within the 2' x 2' area of a floor, ceiling tile or even on the wall. The zone cabling enclosure provides support for any standard 19" patch panels or active equipment as well as RapidNet panels for use with the pre-terminated cassette-based solution. The zone cabling enclosure has a hinged and removable top access door along with removable covers and interchangeable brushes on two sides. The enclosure can be secured to raised floor pillars, concrete flooring or ceiling tiles and walls; making it extremely versatile in any mounted position. Internally, the zone cabling enclosure has front and rear cable management to support patch leads and manage bend radii.

- Dimensions: 20"D x 3.9"H x 19.4"W
- Construction: Not specified.
- RoHS
- For more information:

<https://www.hellermanntyton.com/products/enclosures/zce2uxxxxgy/854-20027>



HellermanTyton Lockable Zone Enclosure

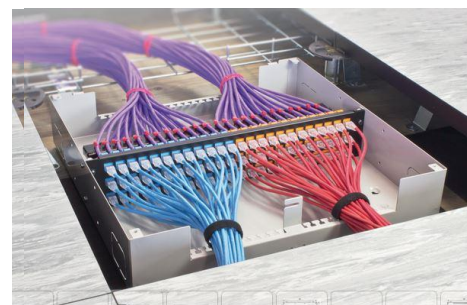

## Conclusion

---

Today's intelligent building standards such as *ANSI/TIA-862, Structured Cabling Infrastructure Standard for Intelligent Building Systems* and *ANSI/BICSI-007 Information Communication Technology Design and Implementation Practices for Intelligent Buildings and Premises* are addressing the unique needs of attaching many building applications, outside of voice and data to the IP network. To provide connection to these devices will create a highway of cables in the digital ceiling. Cable management solutions will be required at the design stages to implement a zone cabling infrastructure.

Zone cabling supports a wide range of sensors, control panels, and detectors for lighting, security, and other building communications, such as wireless access points for WLANs. A zone cabling design consists of horizontal cables run from the telecommunications room (TR) to a horizontal connection point (HCP) that is typically housed in an enclosure located in the ceiling space, on the wall, or below an access floor. From the connection point, cabling is run to service outlets (SOs) for connections to devices. The use of zone cabling provides a flexible infrastructure to accommodate current and future data, voice, building devices, and wireless access points.

Many system designers and consultants are referring to the standards' recommendations to utilize HCPs in a zone topology for intermediate connections (interconnects or cross connects) from the telecom rooms (TRs) to the end devices. According the ANSI/BICSI-007 Standards, "An HCP is a connection point within the horizontal cabling between the TR and the corresponding building service outlet or device and is analogous to the consolidation point used within communication and data networks. HCPs often are the most efficient solution in areas where there is a high density of building system connections. HCPs are commonly used within zone cabling design, as the use of an HCP reduces the length of cable that may need to be pulled or changed as devices are added, moved, or removed. For most building systems, an HCP may be configured as an interconnect (i.e., one patch panel or connecting block) or a cross-connect (i.e., two patch panels or connecting blocks). Unlike a consolidation point, an HCP may be either active or passive."

FSR already offers three different ceiling boxes that could easily transform to HCPs allowing both passive and active components to be securely terminated which provide both termination for data cables and termination to AC outlets for active components. Pictured to the right is an example of the CB-224 used in a PON environment. Pictured are the ONTs that were mounted vertically on the door and allowed easy termination of the singlemode cable as well as the AC needed for the active components.



FSR CB-224 in a PON installation

In addition, FSR has been utilizing these ceiling boxes for other applications and have been "jury rigging" the inside to accommodate additional equipment such as additional power strips. Other manufacturers, as mentioned in this report, have not exhibited engineered flexibility as much as the FSR AV ceiling boxes.

Keeping in mind that many of these devices will be enabled through PoE, AC outlets will be minimized but other components such as PoE switches and media converters will require AC connectivity. Minimal redesign will be needed and should focus on flexibility for accepting different cable types with properly sized knockouts, as well as keeping proper bend radius for the cables and distance separation between data cables and power cables. And, in addition, because PoE means running Class 2 power through the data cable, there are heat issues when pushing high PoE (60W+) through the cable and being particularly aware of heat within cable bundles. Refer to the NEC 2020 Code and any TIA TSB standards that address proper best practices for safety and to protect signal degradation. When an HCP is installed above a suspended ceiling or other defined environmental spaces (e.g., plenum, riser), the HCP shall conform to applicable space and clearance requirements. HCPs shall be administered in the same manner as telecommunications cabling, connecting hardware, pathways, and spaces as specified in applicable standards.



FSR CB-224 with fiber, copper and AC connectivity

The standards also recommend that TEs that support power and data transmission that are located in limited access spaces shall be located so all enclosure doors or panels may open a minimum of 90 degrees. According to the ANSI/BICSI-007 standard, an opening not smaller than 560 mm x 560 mm (22 in x 22 in) shall be provided for TEs above suspended ceilings and an opening not smaller than 560 mm x 760 mm (22 in x 30 in) for TEs located in crawl spaces.



FSR CB-224 with fiber, copper and with an added power strip

These enclosures will need to have proper venting as well as meeting plenum rating. FSR ceiling boxes conform to UL 2043: UL Standard for Safety Fire Test for Heat and Visible smoke for Discrete Products and their Accessories installed in Air Handling spaces. Safety Rated: Conforms to UL 60950-1: Information Technology Equipment – Safety and certified to CSA 22.2 60950-1 Safety of Information Technology Equipment. Consideration should be given to redesign the ceiling boxes to meet additional fire and smoke safety standards, such as FSR's unique PWB-FR-450, which is the first in-wall box to pass extensive testing by UL, meeting all through-penetration firestopping systems for fire-resistive openings. Standards for fire-resistive tests are found through the American National Standards Institute (ANSI), ASTM, UL and the NFPA. The two most widely accepted are UL 1479, entitled *Fire Tests of Through-Penetration Firestops* and ASTM E-814 (international) *Standard Test Method for Fire Tests of Penetration Firestop Systems*.

In conclusion, FSR has the unique engineering expertise to redesign their existing line of AV ceiling boxes to be transformed into HCPs to address the evolving Intelligent Building markets and in-ceiling applications. By researching the addition of cooling options for PoE cables and active components such as receptacles and by incorporating fire-rated features from their existing PWB-FR-450 wall box to include intumescent firestopping to obtain a higher fire and smoke safety rating, FSR could become the leader in the ICT community for cable management in the ever-evolving digital ceiling.