



EPS - Datasheet

Series EPS/ELR/ELM 5000

The electronic multi-channel DC load of series EPS/ELM 5000 of EPS Electronic Power Supplies is a combination of a 19" 6U rack (EPS/ELR 5000) and up to 10 units of electronic DC load modules EPS/ELM, which can be installed in the rack. The system can be operated standalone or mounted in suitable cabinets.

The load modules are removable, retrofittable and can be installed in an arbitrary number (1-10) and position by the end user. A mixed setup of 80 V and 200 V versions is also possible. The modules run separate from each other and form a multi-channel DC load for industrial applications, for instance to test multiple E.U.T at once. Beyond standard features of electronic loads, set point based runs can be generated by the integrated sequence generator. It offers 100 points for arbitrary configurations of voltage, current, power and time each. The resulting sequence can be stored to or loaded from an USB stick. This is enabled by an USB port on the front side which is standard with these load modules.

For remote control the load modules are provided as standard with an Ethernet port on the front side as well. Net-work configuration is simple and done on the touchscreen control panel. With this port the loads may, for example, be operated together with other load types or even different kind of equipment, all controlled by a PC, PLC or mini PCs, like a Raspberry Pi or PXI.

Optional an Ethernet patch 1U rack which collects up to 10 Ethernet ports of the load modules in an EPS/ELR rack such as an Ethernet switch to a single network connection on the rear of the multi-channel electronic load system is available.

Remote control and/or monitoring is supported by the devices via the protocols ModBus RTU and the prolific SCPI.

The generated DC energy is converted through a high efficiency internal inverter and fed back as AC energy into the 230 V mains.

All models are controlled by microprocessors. These enable an exact and fast measurement and display of actual values.

A further option are the preconfigured cabinet systems and Profisoftware.

Energy Efficiency: Energy recovery, high efficiency, temperature regulated fans

Scope of delivery:

EPS/ELM 5000

-Load module

-USB-Stick with manual and Software

EPS/ELR 5000

-19" 6U Rack

-AC mains cable (CEE)

-Screw set (50 pcs.)

EPS/ELM 5200-10 Electronic Load module with mains backfeed



EPS/ELM5200-10 Module

General datas

Technology	Switching
Operation modes	CC.CV.CP
Input Current Limitation	Standard
Power feed back	Standard
Display	HMI TFT Touch Panel
Voltage resolution	0,01 V
Voltage accuracy	<=0,1%
Voltage Stability Load	<0,05% (0-100%)
Current Resolution	0,001 A
Current Accuracy	<=0,2%
Current Stability Load	<0,15% (0-100%)
Power Accuracy	<=0,2%
Overheat protection	Standard
Parallel operation	Standard
Cooling	Fan
Operation temperature	0-50°C
Storage temperature	-20...70°C
Humidity	<80% n.c
Attitude	2000m /NN
Design	19 inch
Standards	EN60950, EN50160 (class 2)
Power fail	Standard

Interfaces

USB Interface	Standard Typ A
Ethernet Interface	Standard
Software	Option EPS/PC

Technical datas

Input Power	0-320 W
Input Voltage	0-200 VDC
Input Current	0-10,2 A
Efficiency	>92%
Remote Sensing	Standard
Dimensions in mm (WxHxD)	81 x 132,5 x 310
Weight	2,35 kg
Order code	124182

Options

Option 1	19" Rack EPS/ELR 5000
Option 2	Blind panel EPS/ELM FP
Option 3	Mains monitoring module EPS/ELR ENS (BISI)
Option 4	Extended Warranty EPS/G
Option 5	Ethernet Patch Rack EPS/ELR 5000-LAN

EPS/ELR5000 Rack



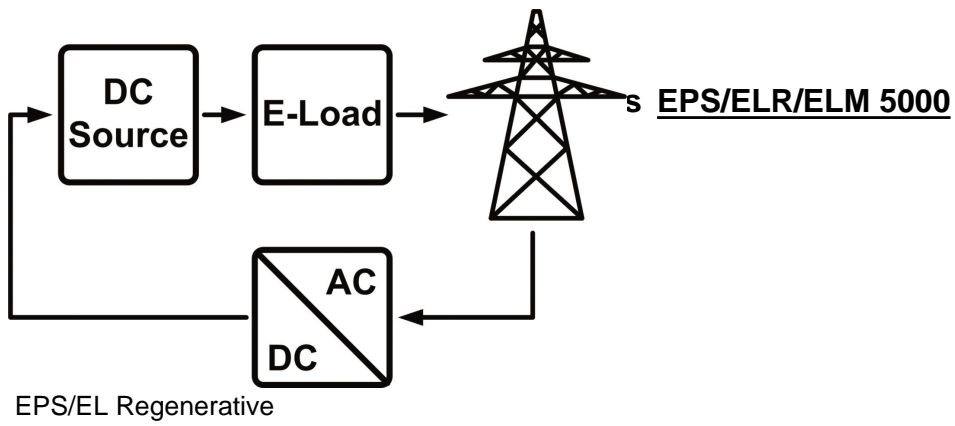

Subject to modification without notice, errors and omissions excepted

EPS Stromversorgung GmbH
Electronic Power Supplies
Alter Postweg 101 86159 Augsburg
Tel.: +49 (0) 821 570451-0
Fax.: +49 (0) 821 570451-25
E-mail: info@eps-germany.de
www.eps-germany.de