

IMPORTANCE OF BEING EARNEST MODEL - DIRECTOR'S GROUNDPLAN

Show
Logo

Production Name

Venue

Designer: Emma Gregory

Notes/Disclaimer

Director:
Technical Director:
Lighting Designer:
Costume Designer:
Sound Designer:
Projection Designer:

Date:
Version #:
Scale:

Page:

of #

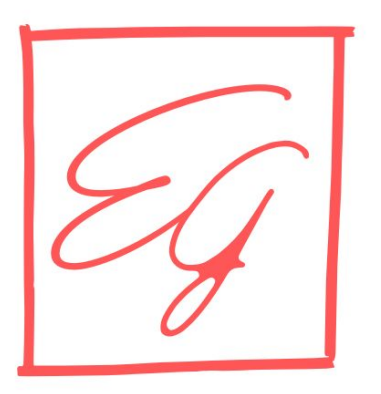

Show
Logo

Production Name

Venue

Designer: Emma Gregory

Notes/Disclaimer

Director:
Technical Director:
Lighting Designer:
Costume Designer:
Sound Designer:
Projection Designer:

Date:
Version #:
Scale:

Page:

of #

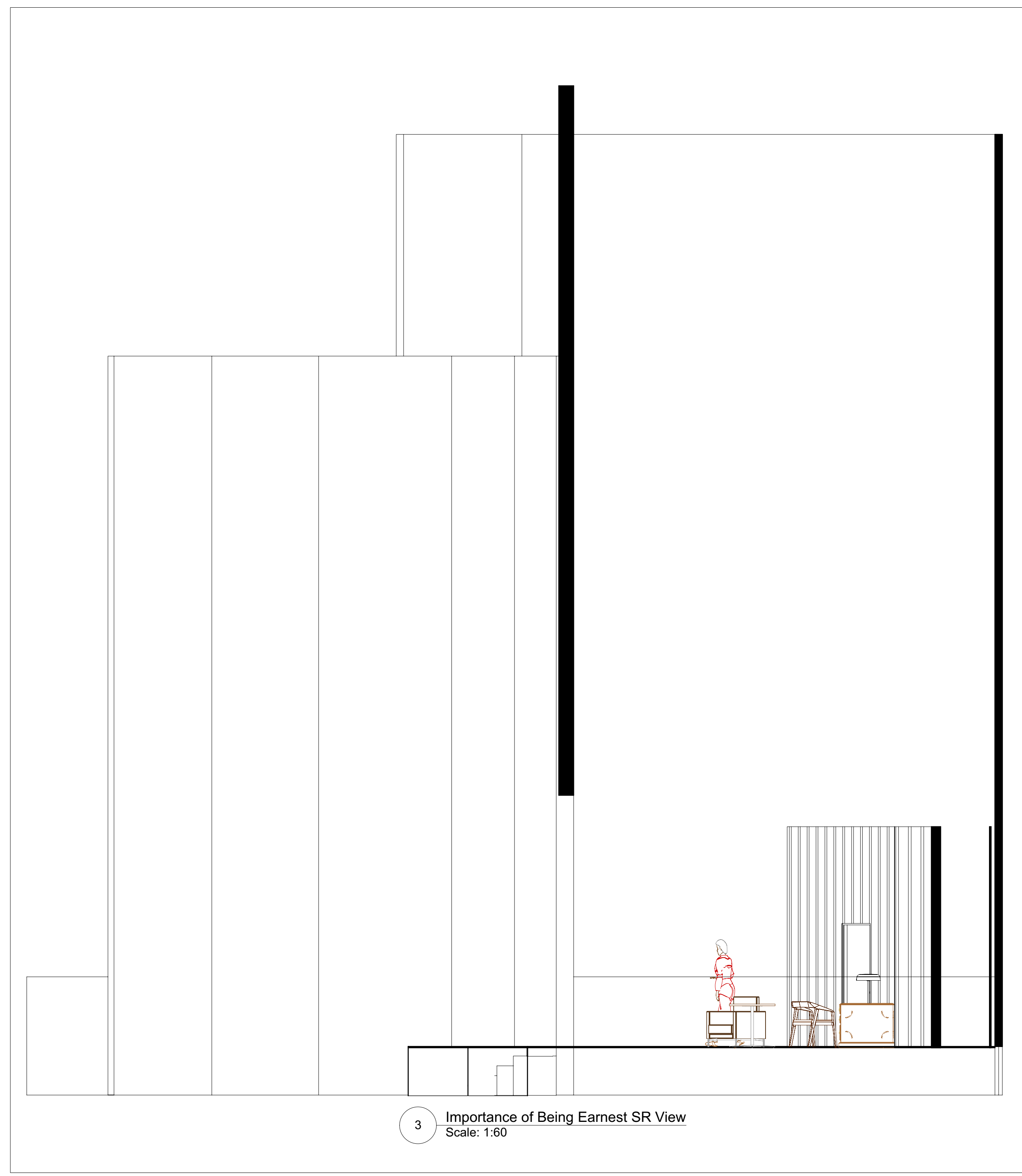
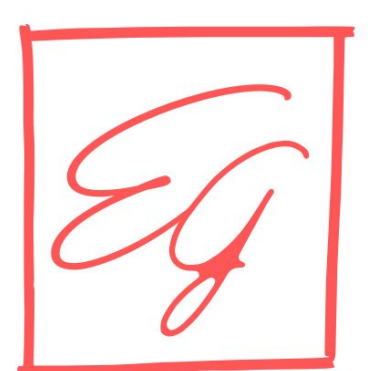

3 Importance of Being Earnest SR View
Scale: 1:60

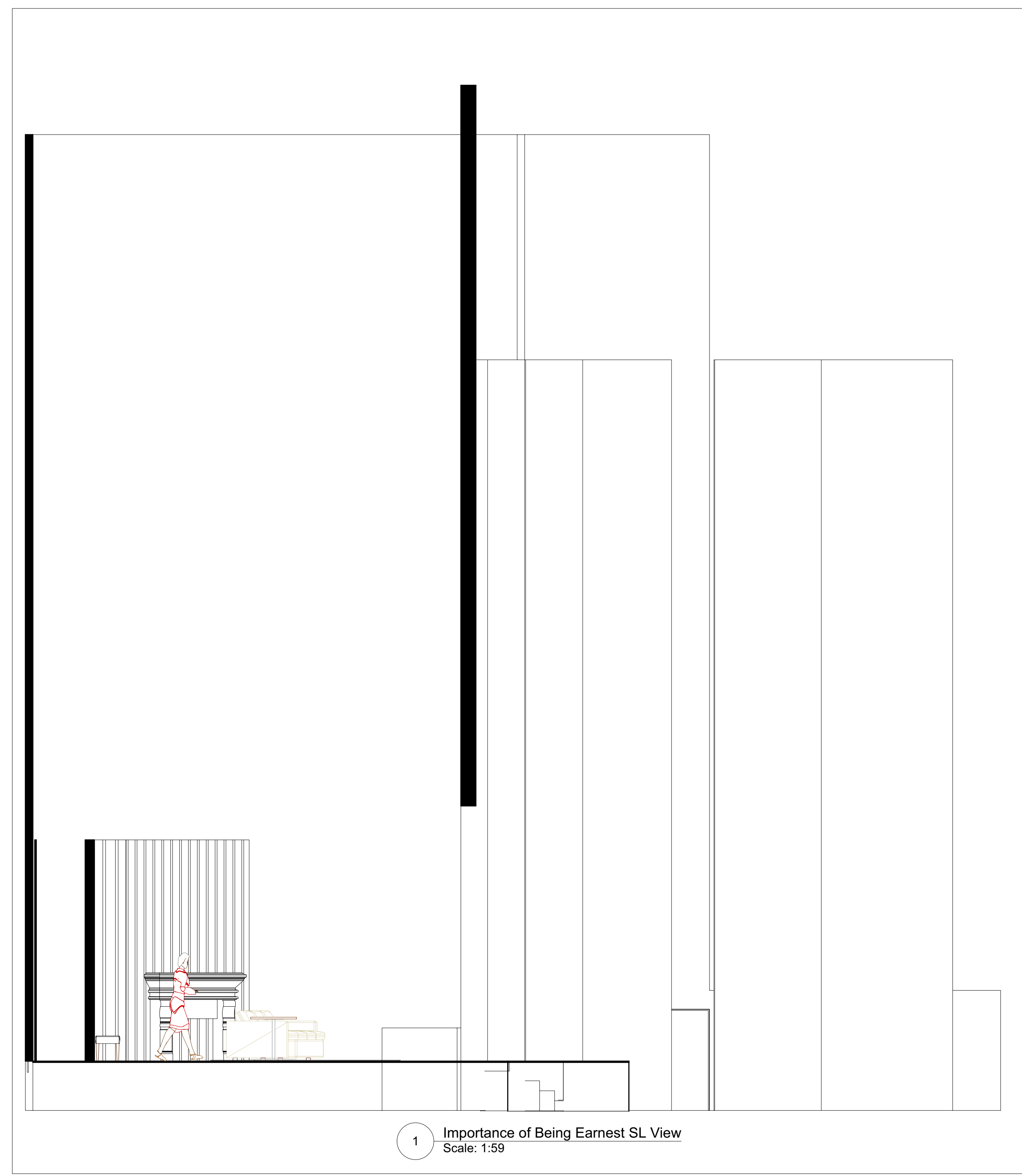

1 Importance of Being Earnest SL View
Scale: 1:59

IMPORTANCE OF BEING EARNEST MODEL - VERTICAL SECTION VIEWS

A

A

B

B

Show
Logo

Production Name

Venue

Designer: Emma Gregory

Notes/Disclaimer

Director:
Technical Director:
Lighting Designer:
Costume Designer:
Sound Designer:
Projection Designer:

Date:
Version #:
Scale:

Page: #
of #

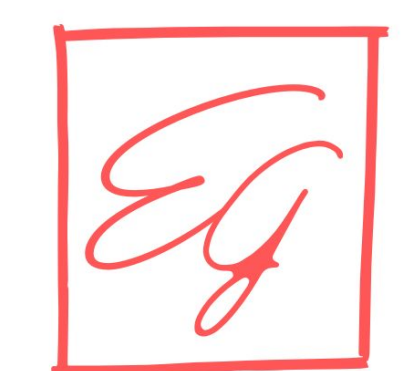

2 Importance of Being Earnest SR Isometric View
Scale: 3/8" = 1'-0"



1 Importance of Being Earnest SR Isometric View
Scale: 1:35

IMPORTANCE OF BEING EARNEST MODEL - ISOMETRIC VIEWS

A

A

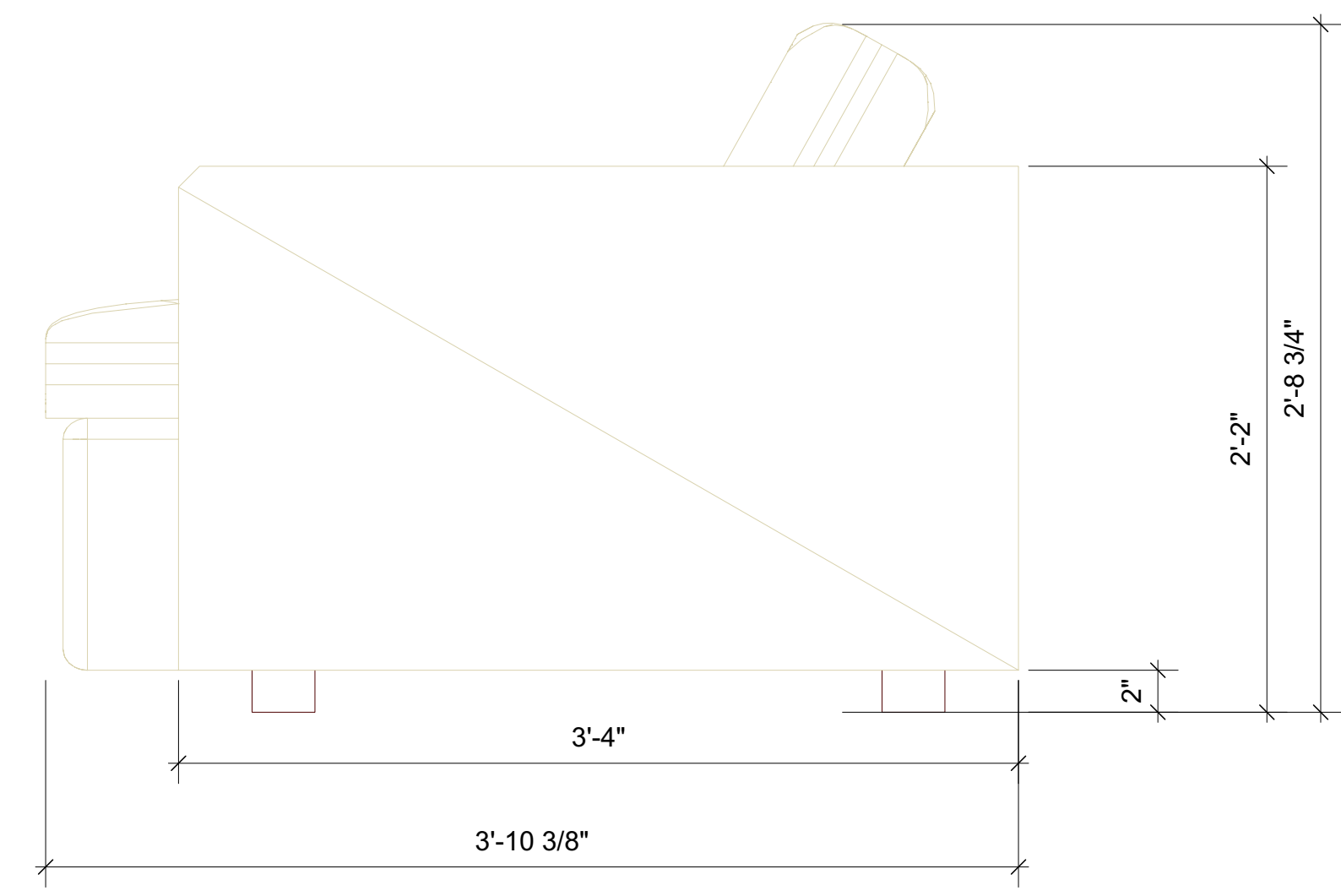
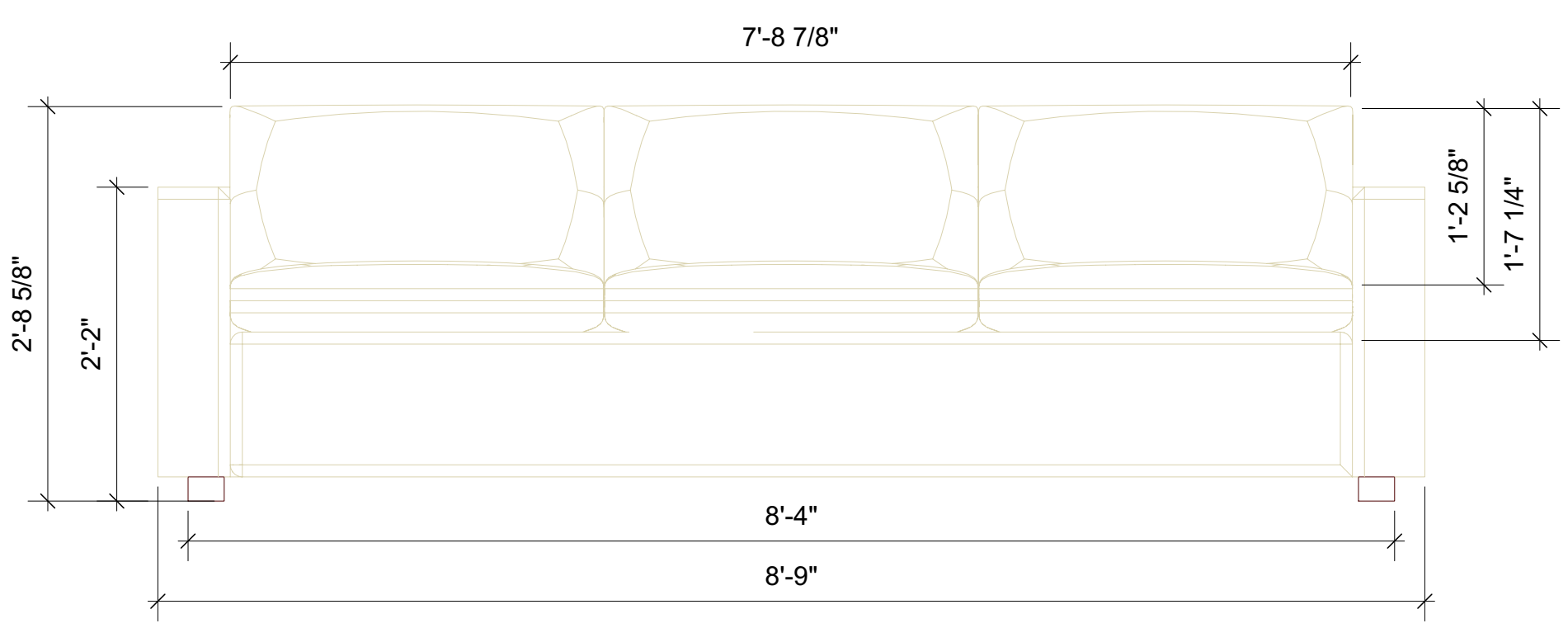
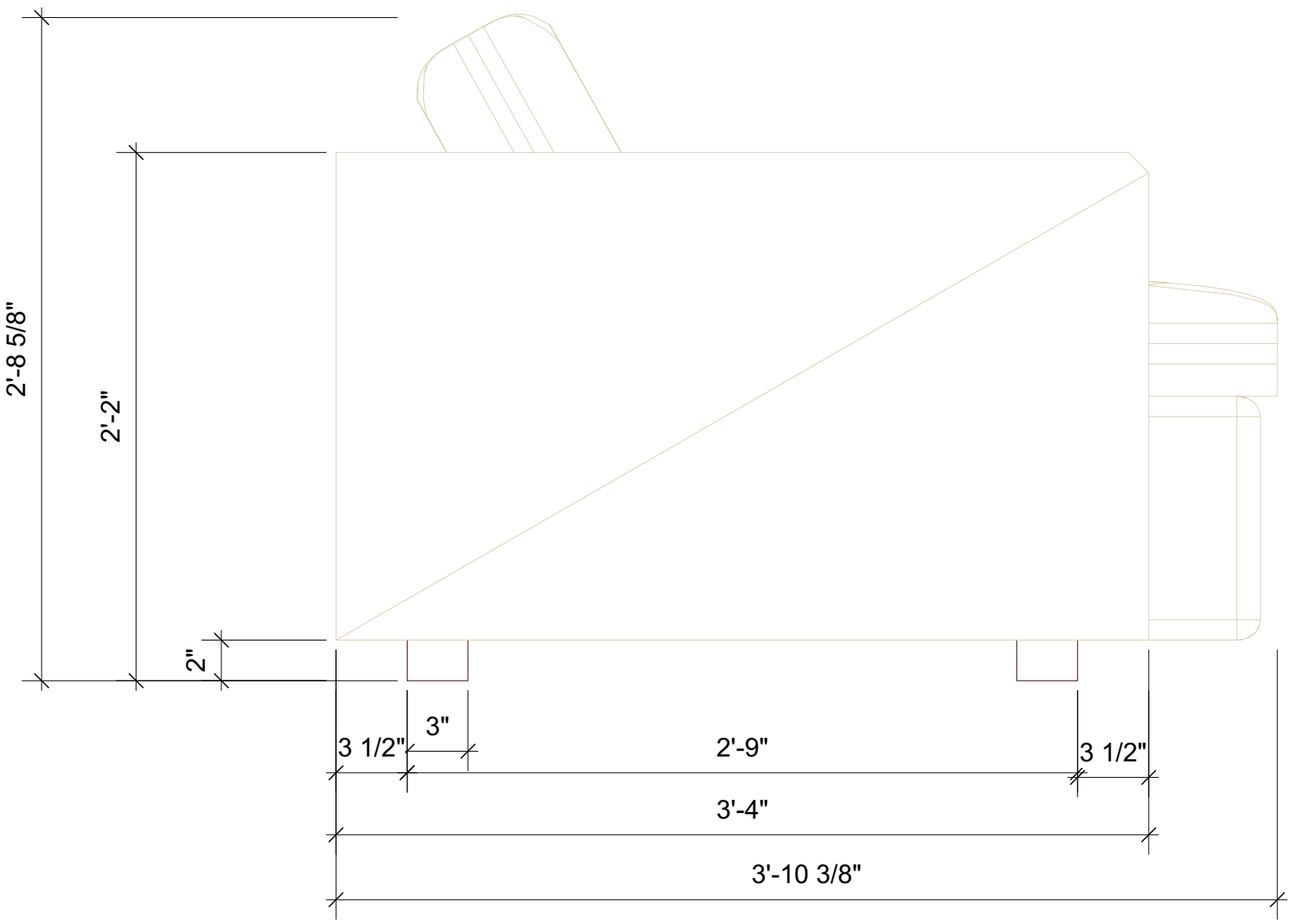
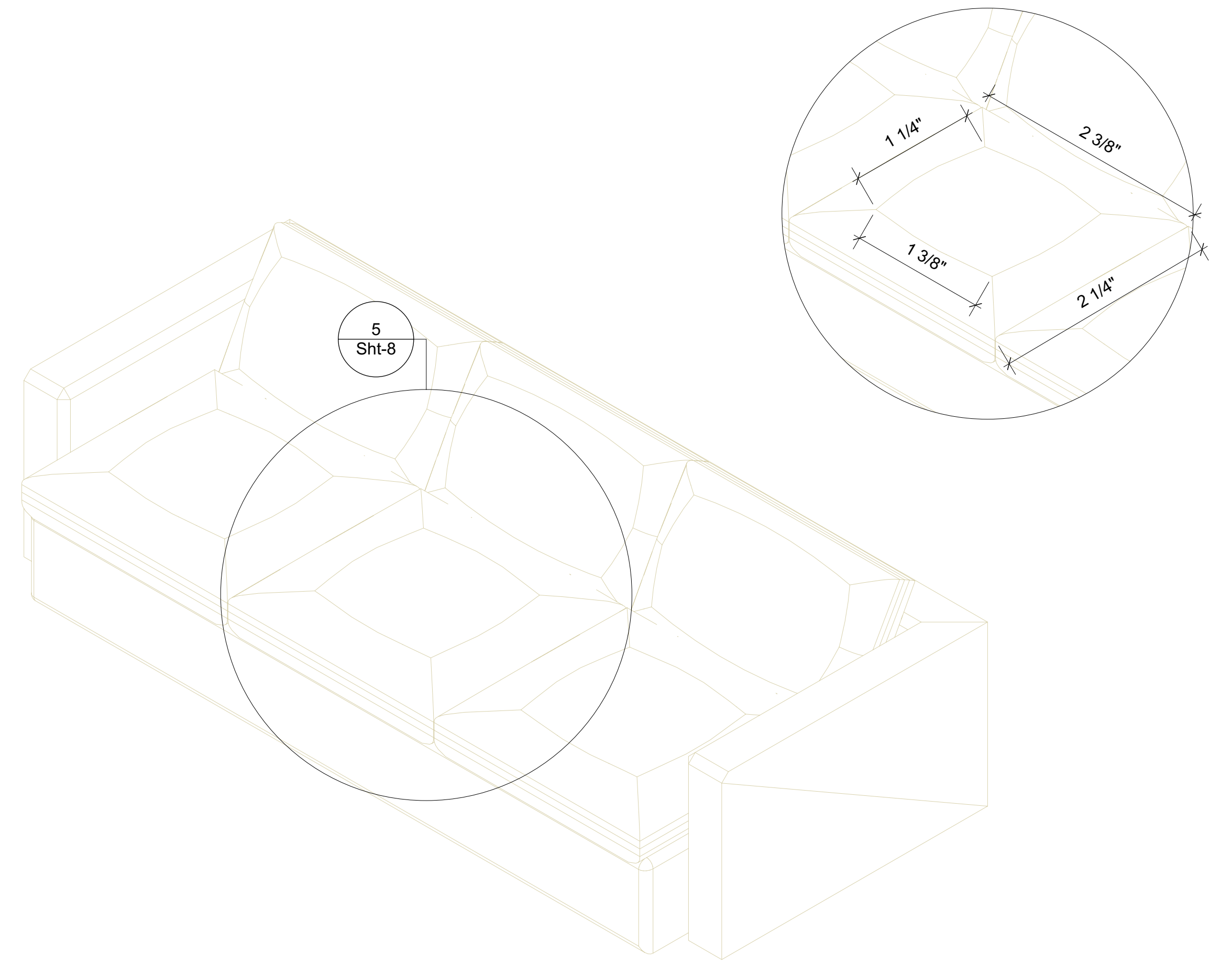
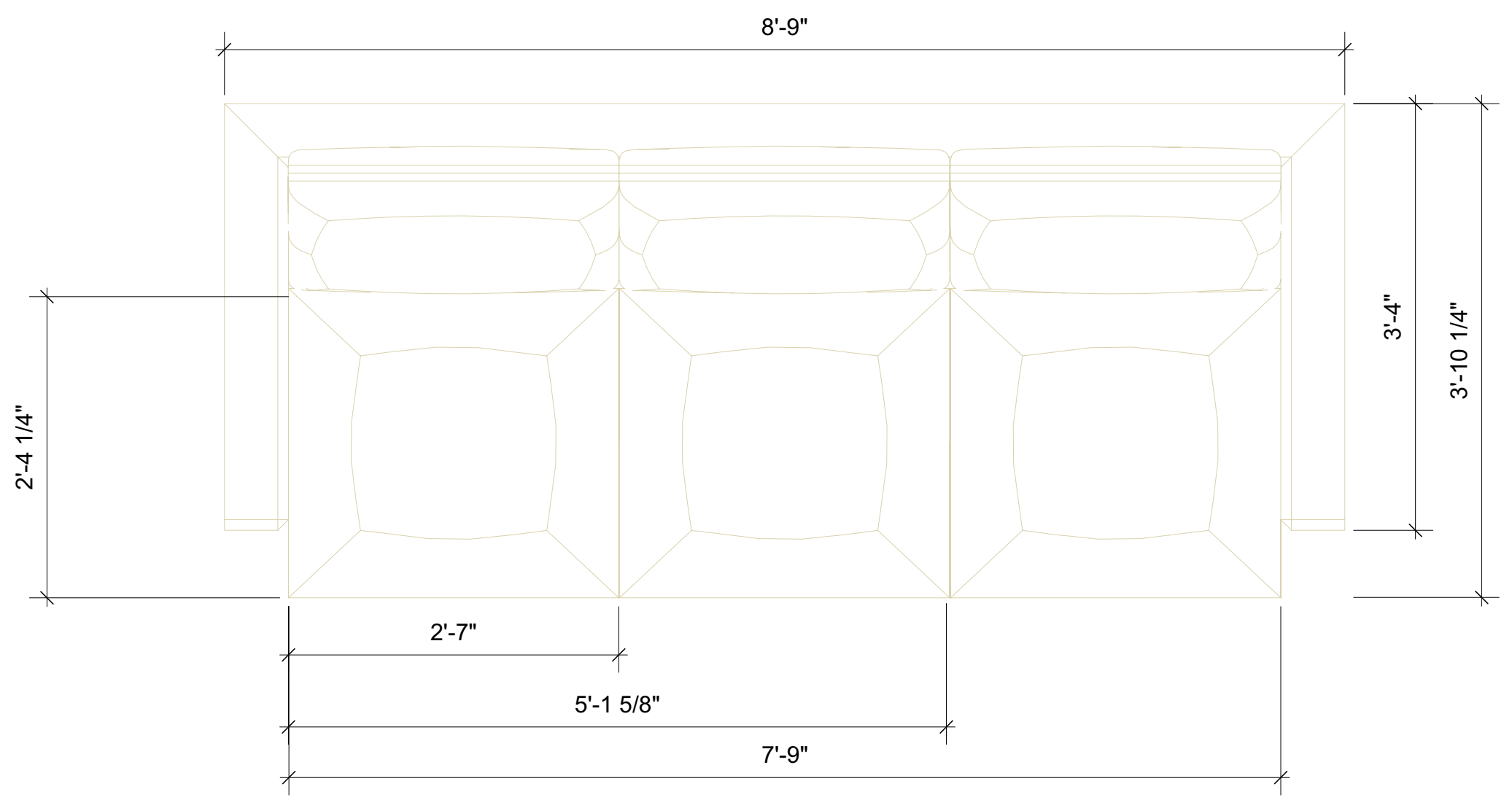

B

B

IMPORTANCE OF BEING EARNEST MODEL - SOFA ORTHOGRAPHIC VIEWS

Show
Logo

Production Name

Venue

Designer: Emma Gregory

Notes/Disclaimer

Director:
Technical Director:
Lighting Designer:
Costume Designer:
Sound Designer:
Projection Designer:

Date:
Version #:
Scale:

Page:

of #

