

SUBMITTAL DATA SHEET



**AFFINITY™ SERIES 2-STAGE
SPLIT SYSTEM AIR CONDITIONERS
19 SEER – R-410A – 1 PHASE – 2 THRU 5 NOMINAL TONS
MODELS: YXT24 THRU 60**

JOB NAME:			LOCATION:		
PURCHASER:			ORDER NO:		
ENGINEER:					
SUBMITTED TO:		FOR:	REF:	APPROVAL:	CONSTRUCTION:
SUBMITTED BY:			DATE:		
UNIT DESIGNATION:			SCHEDULE NO.	MODEL NO.	

PRODUCT DATA

Cooling Performance	
Total Capacity _____	MBH
Outdoor Design Temp _____	°F
Heating Performance	
Total Capacity _____	MBH
Outdoor Design Temp _____	°F
Electrical Data	
Power Supply _____	/ / _____
Compressor Ampacity _____	AMPS
Total Unit Ampacity _____	AMPS
Power Input Req _____	KW
Minimum Wire Size _____	AWG
Maximum Overcurrent Device	
<input type="checkbox"/> Fuses	<input type="checkbox"/> Circuit Breaker
Unit Weight	
Unit Weight _____	LBS

DIMENSIONS - INCHES

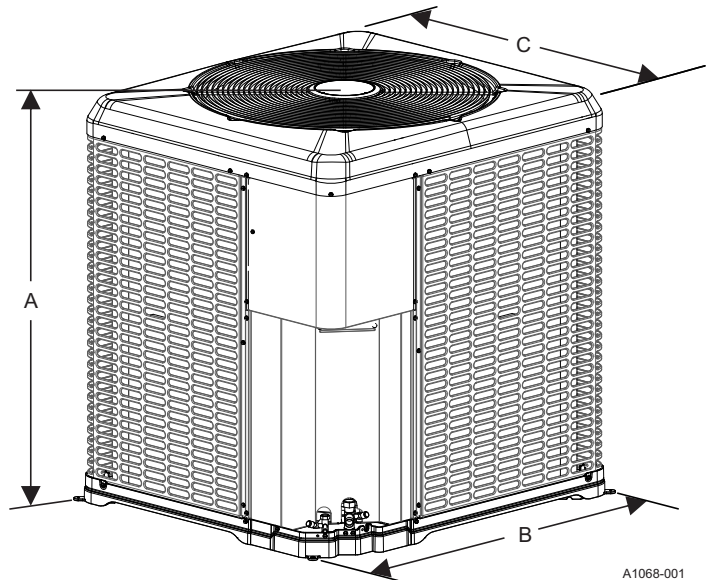

A1068-001

Unit Model	Dimensions (Inches)			Refrigerant Connection Service Valve Size	
	A	B	C	Liquid	Vapor
YXT24B21S	40-1/4	38-1/4	34-1/2	3/8	3/4
YXT36B21S	46-1/2	38-1/4	34-1/2		7/8
YXT48B21S	46-1/2	38-1/4	34-1/2		7/8
YXT60B21S	46-1/2	38-1/4	34-1/2		7/8 [‡]

‡ Adapter fitting must be field installed for the required 1-1/8" line set.
All dimensions are in inches and are subject to change without notice.
Overall height is from bottom of base pan to top of fan guard.
Overall length and width include screw heads.

WARRANTY SUMMARY*

Extended 10-Years limited parts warranty.
Extended Lifetime limited compressor warranty.
Extended parts and compressor warranties require online registration within 90 days of purchase for replacement or closing for new home construction.

*Does not apply to 3-Phase models, or Internet sales.
See Limited Warranty certificate in User's Information Manual for details.



FEATURES

- **Superior Coil Protection** – An easily removable two-piece steel extruded louver coil guard protects the tube-in-fin coil from debris and physical damage while making access for coil cleaning quick and simple.
- **Environmentally Friendly Refrigerant** – The next generation refrigerant R-410A delivers environmentally friendly performance with zero ozone depletion.
- **Durable Finish** – A high quality powder paint finish rated at 1000 hrs. salt spray provides the ultimate protection from corrosion and harmful UV rays, ensuring a long-lasting, high quality appearance.
- **QuietDrive™ System** – Features a combination of engineered, sound-neutralizing attributes such as a swept-wing fan blade, composite base pan, multi-density compressor cloak and two-speed compressor operation to reduce sound levels to that of a mere conversation.
- **ECM Fan Motor** – Dynamically adjusts speed in sync with the outdoor temperature stage to keep heat exchange in balance while minimizing power consumption and sound.
- **Swept Wing Fan** – A design adapted from aerospace engineering provides whisper-quiet operation by allowing air to flow smoothly and efficiently across the fan surface and edges.
- **Composite Base Pan** – The strong and durable composite base pan is corrosion resistant while adding strength, absorbing sound, and reducing vibration.
- **High-Efficiency Outdoor Coil** – An aluminum fin and copper tube outdoor coil provide easy cleaning, low restriction to airflow and efficient heat exchange.
- **Factory Installed Filter-Drier** – A corrosion resistant copper, solid core liquid line filter-drier removes debris and moisture which can be harmful to the system.
- **Climate Set™** – provides pre-configured operating profiles the installing contractor can select during set-up to fine tune the system's operation for either Humid, Dry, or Normal climates. Additional fine-tune adjustments are always available to provide a custom comfort solution. (Feature available when a variable speed indoor air mover is utilized).
- **Easy Service Access** – A large electrical box cover and a swing open electrical box provide superior full corner access to the inside of the unit for maintenance or service.
- **TXV Controls** – All indoor coils, whether in the cased CF/CM coil or in air handlers, may use dealer installed TXV's or indoor equipment with factory installed TXV's.
- **Communications Capable** – Designed to operate as a conventionally wired system or as a communicating system requiring only 4 thermostat wires between the outdoor and indoor units, the communicating system provides self-commissioning on start-up as well as the ability to check system status at the outdoor unit, thermostat, or remotely using the designated mobile application.
- **Two Speed, Protected Scroll Compressor** – The compressor is solenoid operated for 67% and 100% capacity. A suction accumulator tank protects the compressor from harm.

- **Advanced System Control** – The proprietary wi-fi Hx™ thermostat interface is an integral part of this innovative system design. Using the Consumer mobile application, consumers can monitor and adjust their system from anywhere in the world using a smart device. Contractors can use the Service application (with homeowner permission), to monitor the system remotely and make adjustments as needed. The system can be configured to provide alerts for emerging issues as well as items that require immediate attention.
- **Agency Listed** – Safety certified by CSA to UL 1995 / CSA 22.2. Performance certified to ANSI/AHRI Standard 210/240 in accordance with the Unitary Small Equipment certification program.

TYPICAL CLEARANCES

The minimum clearances for a typical installation are shown below. See the Technical Guide for alternate installations.

- 10" Clearance Coil Area
- 48" Overhead Clearance
- 18" Minimum Service Panel Access
- 24" Minimum Unit to Unit Distance

MATCHING AIR SIDE EQUIPMENT

Model No. _____
Submittal Form No. _____

FIELD INSTALLED ACCESSORIES

Start Assist Kit (S1-2SA067_____) *
Compressor Crankcase Heater Kit (S1-025-_____) *
Indoor Blower-Off Delay Kit (S1-2FD06700224)
Support Feet (S1-HPRKIT-_____) *
Anchor Bracket Ground Mount Kit (S1-1HK0701)
Anchor Bracket Roof Mount Kit (S1-1HK0901)
Indoor TXV Kit (S1-1TVM_____) *
Wall Mount Kit (S1-ACB-_____) *
Winter Cover Kit (S1-CCVRE_____) *
Cold Weather Charging Tent (S1-CHGTENT01)
Touch-up Paint (S1-5130153_____)

Thermostat: Compatible thermostat controls are available through accessory sourcing. For optimum performance, these outdoor units are fully compatible with our York Hx™ Touchscreen Thermostats available through Source1. For more information, see the thermostat section of the Product Equipment Catalog.

* See price pages for accessory information.

Refer to Technical Guide for detailed specifications on the unit and its accessories.

Verify the actual ratings for each specific match-up in the online AHRI directory at www.ahridirectory.org at the time of bid or sale. It is also recommended to print the rating certificate, if needed, at the time of bid or sale.