



# CATALOG

# Elastimold®

Underground cable accessories

---

CATALOG

# Underground cable accessories

 elastimold®





—

**Starting with the first underground elbow connector, the Elastimold brand became a leading innovator of cable accessories that enhance safety and save time, space and money for utility companies.**

**Pioneer products include extended and repair elbows, jacket seal elbows, shrink-fit joints and more. Used to connect, ground, splice, terminate and protect underground cables from 5 kV to 38 kV, Elastimold underground cable accessories are designed, assembled, 100% tested and stocked in the USA.**

---

# Table of contents

<b>004–006</b>	<b>Overview</b>
<b>007–018</b>	<b>200 A loadbreak elbows and separable connectors and deadbreak separable connectors</b>
<b>019–052</b>	<b>600 A deadbreak separable connectors, spiking and grounding aid cable accessories and separable cable joints</b>
<b>053–056</b>	<b>Multi-point junctions</b>
<b>057–062</b>	<b>ComboT integral separable connectors</b>
<b>063–065</b>	<b>Permanent distribution cable joints</b>
<b>066–072</b>	<b>Distribution shrink-fit terminations</b>
<b>073</b>	<b>Pre-molded terminations</b>
<b>074–075</b>	<b>Cable shield adapters, jacket shields and equipment bushings</b>
<b>076–085</b>	<b>Technical information</b>
<b>086–087</b>	<b>Fuse ordering information</b>
<b>088–097</b>	<b>Shielded surge arresters</b>
<b>098–105</b>	<b>Transmission cable joints and terminations</b>
<b>106–109</b>	<b>Index</b>



# Elastimold® underground cable accessories

## Overview

Elastimold® separable connectors, cable joints, cable terminators and other cable accessory products have been designed and tested per applicable portions of IEEE, ANSI and other industry standards including:

- IEEE 386 standard for separable connectors
- IEEE 404 standard for cable joints and splices
- IEEE 48 standard for cable terminations
- IEEE 592 standard for exposed semiconducting shields
- ANSI C119.4 standard for copper and aluminum conductor connectors
- AEIC CS8 standards for XLP and EPR insulated cables
- ICEA S-94-649-2004 and S-97-682-2000 standard for cables rated 5,000 – 46,000 V

### Cable joints and terminations ratings

Refer to the pages listed below for rating information:

- PCJ™ cable joints, page 63
- Cable terminations, page 68

### Separable connector ratings

The following chart shows voltage and current ratings that apply to all separable connectors, including 200 A loadbreak, 200 A deadbreak and 600/900 A series deadbreak products. The next chart shows switching and fault close ratings, which only apply to 200 A loadbreak connectors.

### Voltage and current ratings

	15 kV class ratings	25 kV class ratings	35 kV class ratings
Operating voltage maximum line-to-ground (kV) (see application info note 1)	8.3	15.2	21.1
BIL impulse withstand 1.2 x 50 microsecond wave (kV)	95	125	150
Withstand voltage AC one minute	34	40	50
DC 15 minute (kV)	53	78	103
Corona extinction level @ 3pc sensitivity (kV)	11	19	26
200 A products Continuous current: Symmetrical momentary current:	–	–	200 A 10 kA sym, 10 cycle duration*
600 Series products Continuous current: Symmetrical momentary current:	–	–	600 and 900 A 25 kA sym, 10 cycle duration*

\* Designed for 90 °C maximum continuous operating temperature.



**Application information:**

1. Loadbreak connectors are designed and rated for use on grounded Wye systems. For application on ungrounded Wye or delta systems, the next higher voltage class product is recommended.

Examples:

- 5 kV ungrounded: use 15 kV class products;
- 15 kV ungrounded: use 25 kV class products;
- 25 kV ungrounded: use 35 kV class products.

2. Products are designed and constructed for all applications, including padmount, subsurface, vault, indoor, outdoor, direct sunlight, direct buried and continuously submerged in water.

3. Products are designed and rated for ambient temperatures of -40 °C to 65 °C. It is recommended that loadbreak connectors be hotstick operated at -20 °C to 65 °C ambient temperature range and at altitudes not exceeding 6000 feet.

**Switching and fault close ratings**

	Loadmake/loadbreak switching	Fault close
15 kV class ratings	1 $\emptyset$ and 3 $\emptyset$ circuits 8.3 kV line to ground, 14.4 kV max. across open contacts 10 loadmake/break operations at 200 A max. with 70 to 80% lagging power factor	1 fault close operation at 8.3 kV or 14.4 kV; 10,000 A RMS sym; 10 cycles (0.17 sec.) 1.3 max. asym factor applies to new or used mating parts (up to maximum designated switching operations)
25 kV class ratings	1 $\emptyset$ and 3 $\emptyset$ circuits 15.2 kV line to ground, 26.3 kV max. across open contacts 10 loadmake/break operations at 200 A max. with 70 to 80% lagging power factor	1 fault close operation at 15.2 kV or 26.3 kV; 10,000 A RMS sym; 10 cycles (0.17 sec.) 1.3 max. asym factor applies to new or used mating parts (up to maximum designated switching operations.)
35 kV class ratings	1 $\emptyset$ and 3 $\emptyset$ circuits 21.1 kV line to ground, 36.6 kV max. across open contacts. 10 loadmake/break operations at 200 A max. with 70 to 80% lagging power factor.	1 fault close operation at 21.1 kV or 36.6 kV; 10,000 A RMS sym; 10 cycles (0.17 sec.) 1.3 max. asym factor applies to new or used mating parts (up to maximum designated switching operations)

\* Designed for 90 °C maximum continuous operating temperature.

## Elastimold® underground cable accessories

### Overview





#### Standard interfaces for separable connectors, components and equipment bushing

The latest revision of IEEE standard 386 defines the specific interface dimensions to which 200 A and 600 series elbows, inserts, junctions, equipment bushings and any mating components must

conform to ensure interchangeability.

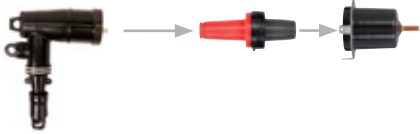
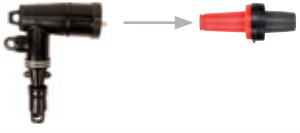
The table below provides information concerning the types of interfaces supplied by Elastimold products for various applications and is useful to ensure proper matching of components.

#### Types of interfaces supplied by Elastimold

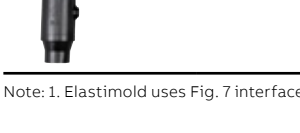
	Bushing interface	Voltage class (kV)	Interface description	Standard no. Figure no.
	200 A deepwell equipment bushing	15, 25 and 35	200 A bushing well interface 8.3 kV, 15.2 kV and 21.1 kV	IEEE 386 Fig. 3
	200 A loadbreak insert	15	200 A loadbreak 8.3 kV and 8.3 kV/14.4 kV	IEEE 386 Fig. 5
	200 A loadbreak insert	25	200 A loadbreak 15.2 kV and 15.2 kV/26.3 kV	IEEE 386 Fig. 7, Note 1
	200 A loadbreak insert	35	200 A loadbreak interface no. 2 21.1 kV and 21.1 kV/36.3 kV	IEEE 386 Fig. 7, Note 1
	200 A deadbreak insert	15 and 25	200 A deadbreak 8.3 kV and 15.2 kV	IEEE 386 Fig. 4
	600 Series equipment bushing	15 and 25	600 A deadbreak interface no. 1 8.3 kV and 15.2 kV	IEEE 386 Fig.11
	600 Series equipment bushing	35	600 A deadbreak interface no. 1 21.1 kV	IEEE 386 Fig.13

Note: 1. Elastimold uses Fig. 7 interface for both 25 and 35 kV applications.



## 200 A loadbreak elbows

### Connectors and accessories

200 A loadbreak connectors and accessories provide a convenient method to connect/disconnect cable and equipment on power distribution systems. Loadbreak elbows include provisions for energized operation using standard hotstick tools, allowing loadmake/break operation and a visible disconnect. Components can be isolated with insulated caps, plugs and parking bushings.

Optional accessories allow system grounding, testing, bypass, surge protection and current limiting fusing. Additional connecting points and taps can be provided by use of junctions or feed-thrus.

### Elastimold 200 A loadbreak elbow (15 kV and 25 kV)

#### Switching made easier

The Elastimold 200 A loadbreak elbow (15 kV and 25 kV series) incorporates decades of innovative design and manufacturing experience that directly addresses end users' needs. The design incorporates safety performance features, increases range flexibility and improves life cycle cost reduction. In addition, Elastimold 200-amp loadbreak elbow has Rural Utilities Service (RUS) acceptance from the U.S. Department of Agriculture (USDA), which authorizes its use in rural infrastructure construction and improvements.

#### Enhance safety

- Rigid probe support to ensure proper switching
- No stick interface when used with Elastimold bushings (NEETRAC\* tested)
- Robust stainless-steel pulling eye
- Dual grounding eye positions

#### Increase flexibility

- Additional sizes available
- Improved wider cable ranges
- Easy order system
- Optional integral jacket seal

#### Improve life cycle cost reduction

- Optimized for switching operations
- Lifetime ease of operation and non-stick when used with Elastimold bushings
- Seal system for traditional and jacket seal options

IEEE 386 compliant

ANSI certification

Rural Utilities Service (RUS) acceptance

\* National Electric Energy Testing, Research and Applications Center

## 200 A loadbreak elbows

### Overview

—  
01 15/25 kV class  
—  
02 15/25 kV class

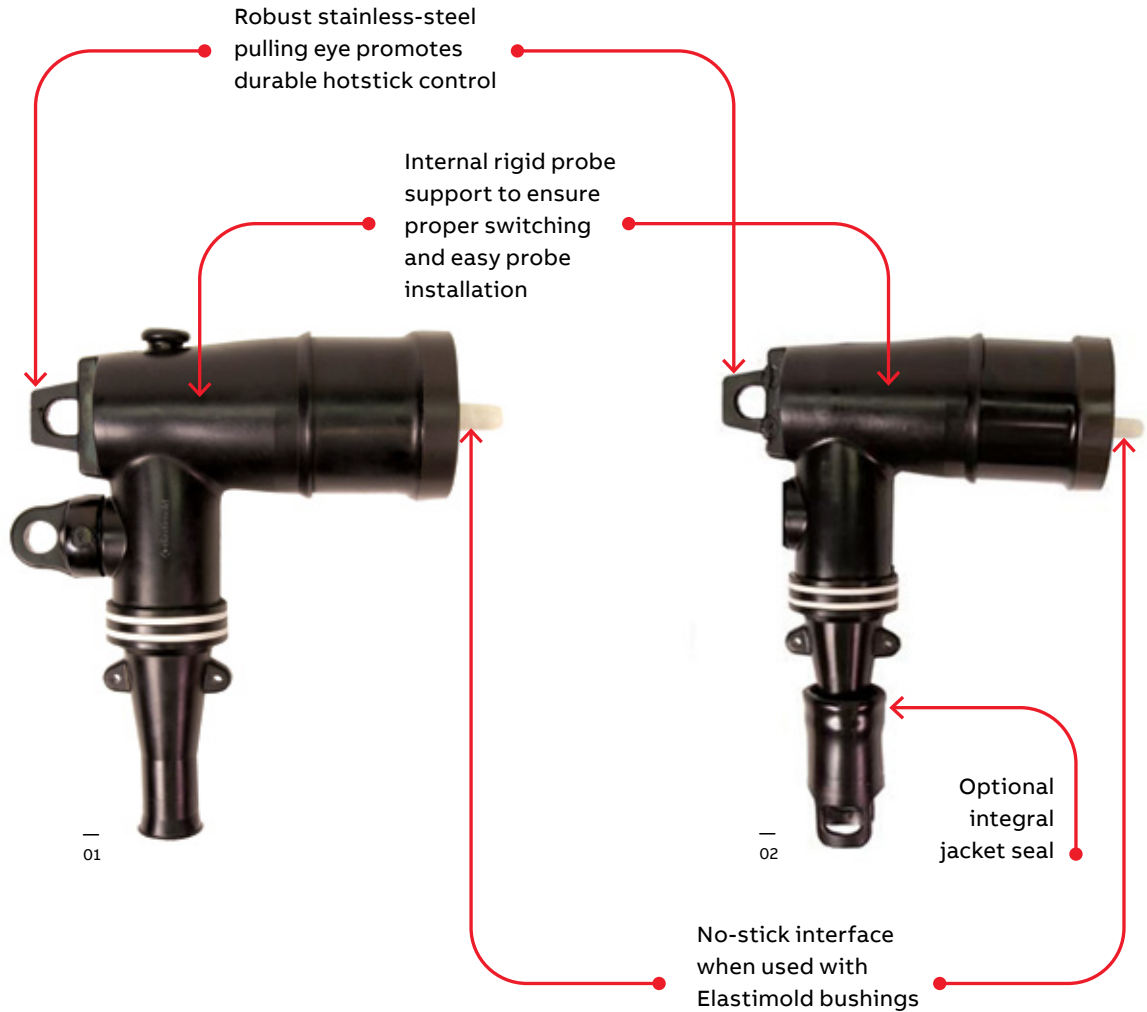

### Ratings overview

See pages 4–5 for complete information, including switching and fault close ratings.

#### Current ratings

- 200 A continuous
- 10 kA sym. 10 cycles

#### Voltage ratings

- 15 kV class
- 8.3 kV phase-to-ground
- 14.4 kV phase-to-phase
- 95 kV BIL
- 34 kV AC withstand
- 53 kV DC withstand
- 11 kV corona extinction

#### 25 kV class

- 15.2 kV phase-to-ground
- 26.3 kV phase-to-phase
- 125 kV BIL
- 40 kV AC withstand
- 78 kV DC withstand
- 19 kV corona extinction

#### 35 kV class

- 21.1 kV phase-to-ground
- 36.6 kV phase-to-phase
- 150 kV BIL
- 50 kV AC withstand
- 103 kV DC withstand
- 26 kV corona extinction

# 200 A loadbreak separable connectors

## Components

### Cable to equipment connections

ABB offers the complete package of underground cable accessories – everything you need to connect, ground, splice, terminate and protect underground

cable from 5 kV to 138 kV – along with solid dielectric switchgear in compact, modular designs that fit easily into tight vaults.

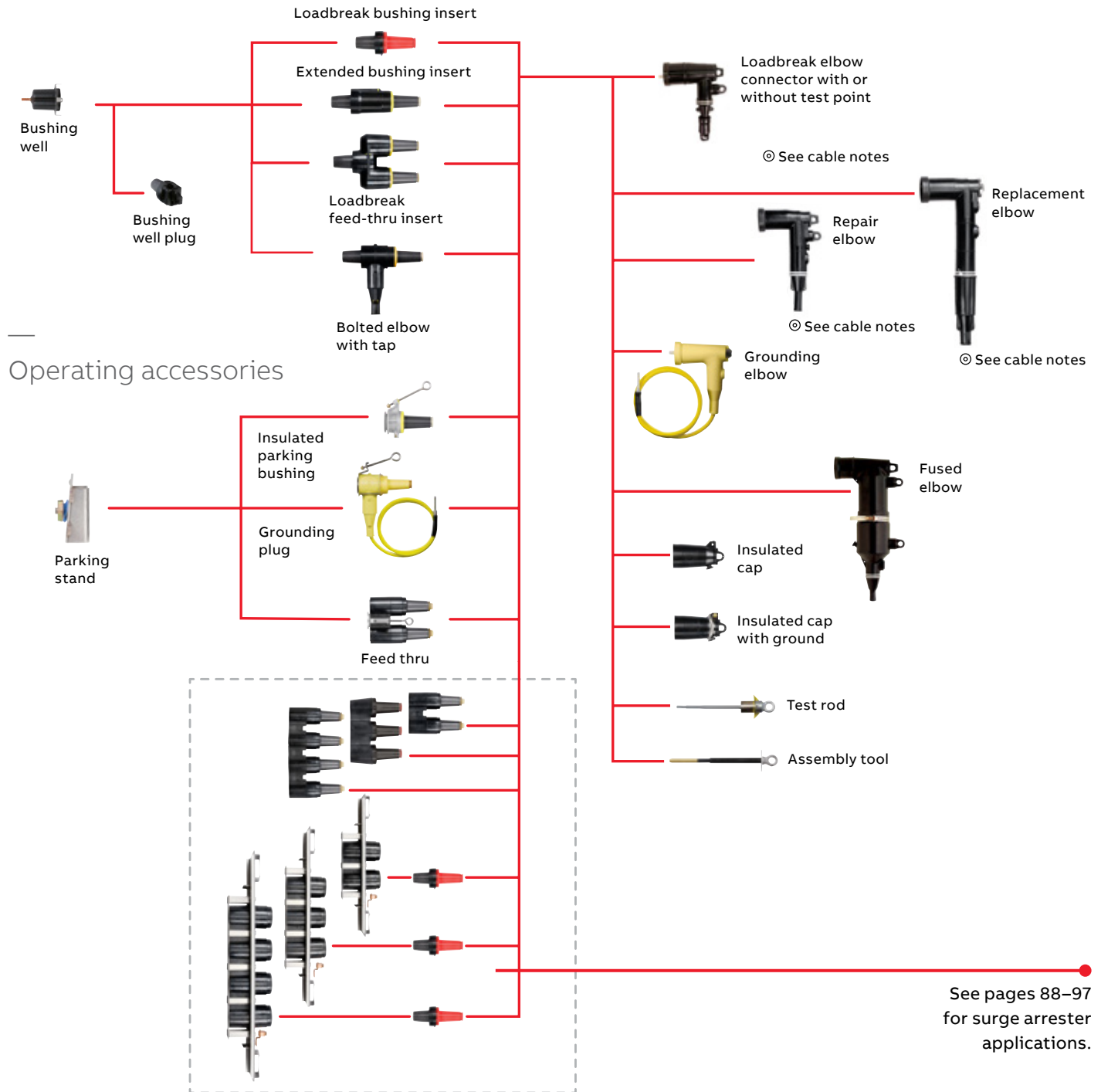



## 200 A loadbreak separable connectors

### Loadbreak elbows

Image (not to scale)	Description	Voltage class (kV)	Cat. no.	Notes
	Elbow connector without test point	15	161LR-W5X Use tables W1 and X1	N2, 3, 4, 5
		25	261LR-W5X Use tables W1 and X1	N2, 3, 4, 5
		35	375LR-W5X Use tables W3 and X2	N2, 3, 5
	Elbow connector with test point	15	162LR-W5X Use tables W1 and X1	N2, 3, 4, 5, 23
		25	262LR-W5X Use tables W1 and X1	N2, 3, 4, 5, 23
		35	376LR-W5X Use tables W3 and X2	N2, 3, 5, 23
	Jacket seal elbow connector without test point	15	161LRJS-W5X Use tables W1 and X1	N2, 19
		25	261LRJS-W5X Use tables W1 and X1	N2, 19
	Jacket seal elbow connector with test point	15	162LRJS-W5X Use tables W1 and X1	N2, 19, 23
		25	262LRJS-W5X Use tables W1 and X1	N2, 19, 23
	Repair elbow connector	15	167ELR-W5X Use tables W5 and X1	N5, 10, 18
		25	273ELR-W5X Use tables W5 and X1	N5, 10, 18
	Repair elbow connector with test point	15	168ELR-W5X Use tables W5 and X1	N5, 10, 18, 23
		25	274ELR-W5X Use tables W5 and X1	N5, 10, 18, 23
	Replacement elbow	15	167RLR-W5X Use tables W4 and X1	N5, 11, 13
		25	273RLR-W5X Use tables W2 and X1	N5, 11, 13
	Replacement elbow with test point	15	168RLR-W5X Use tables W4 and X1	N5, 11, 13, 23
		25	274RLR-W5X Use tables W2 and X1	N5, 11, 13, 23
	Direct test elbow connector	15	161DLR-W5X Use tables W1 and X1	N2, 5, 21
		25	261DLR-W5X Use tables W1 and X1	N2, 5, 21
	Direct test repair elbow connector	15	167DELR-W5X Use tables W5 and X1	N5, 10, 18, 21
		25	273DELR-W5X Use tables W5 and X1	N5, 10, 18, 21
	Direct test repair elbow connector with test point	15	168DELR-W5X Use tables W5 and X1	N5, 10, 18, 21, 23 3
		25	274DELR-W5X Use tables W5 and X1	N5, 10, 18, 21, 2

**N1.** Copper lug for use on COPPER CONDUCTOR ONLY.

**N2.** W5X indicates that the catalog number includes 02500X long bi-metal compression lug as standard. For an all-copper lug, replace W5X with W2X in Table X1 to specify the all-copper 02702X lug.

**N3.** Also available as housing only. Specify: 161BLR-W; 261BLR-W; 375BLR-W; 162BLR-W; 262BLR-W; 376BLR-W.

**N4.** Also available as elbow with insert combination. Specify: 161A4-WX; 261A4-WX; 162A4-WX; 262A4-WX.

**N5.** Also available with 200ECS jacket seal included. Add - "S" suffix to catalog number (highly recommended).

**N10.** Repair elbow has extended length contact and elbow housing resulting in a net gain of 3/4" in length.

**N11.** Replacement elbow has extended-length contact and elbow housing resulting in a net gain of 8/16" in length.

**N13.** Includes long bi-metal contact 00400X.

**N18.** Includes 02509X long bi-metal contact.

**N19.** Includes built-in jacket seal. Also available as housing only – specify: 161BLRJS-W, 162BLRJS-W, 261BLRJS-W or 262LRJS-W. Also available as elbow with insert combination – specify: 161JSA4-W5X, 162JSA4-W5X, 261JSA4-W5X or 262JSA4-W5X.

**N21.** Direct test connectors, along with a 200TC-X series meter adapter, a properly rated voltage meter and hot-line stick provide a means for direct conductor voltage testing.

**N23.** Test point cap catalog number 156-7

Refer to the W and X tables on pages 84–85 for sizing to cable insulation diameter and conductor size. For cable shield adapters and jacket seals, see pages 74–75.

## 200 A loadbreak separable connectors

### Loadbreak bushings





















Image (not to scale)	Description	Voltage class (kV)	Cat. no.	Notes
	Grounding plug (1/0 AWG x 6' ground lead)	15	161GP	-
		25	272GP	-
	Grounding elbow (1/0 AWG x 6' ground lead)	15	160GLR	N12
		25/35	370GLR	N12
	Feed-thru	15	164FT	N6
		25	274FT	N6
		35	371FT	N6
		35	373FT	N6
	Feed-thru vertical	15	164FTV	-
		25	274FTV	-
		35	373FTV	-
	Adjustable bracket 2-point feed-thru	15	164FT2-AB	N22
		25	274FT2-AB	N22
		35	373FT2-AB	N22
	Adjustable bracket 3-point feed-thru	15	164FT3-AB	N22
		25	274FT3-AB	N22
		35	373FT3-AB	N22
	Adjustable bracket 4-point feed-thru	15	164FT4-AB	N22
		25	274FT4-AB	N22
		35	373FT4-AB	N22
	Feed-thru well	15/25	K1601WFT	-
	Feed-thru well vertical	15/25	K1601WFTV	-
	Insulated parking bushing	15	161SOP	N20
		25	272SOP	N20
		35	372SOP	N20
	Insulated parking bushing	15	164SOP	N22
		25	274SOP	N22
	Assembly tool	All	200AT	N8
	Bushing well plug	15/25	276BWP	-
		35	M276BWP	-
	Test rod	All	370TR	-
	Bolted elbow with tap	15	167LRT-W5X Use tables W4 and X1	N17
	Bushing insert	15	1601A4	N4, 8
		25	2701A4	N4, 8
		35	3701A4	N6, 20
		35	3701A3	20

Image (not to scale)	Description	Voltage class (kV)	Cat. no.	Notes
	Extended bushing insert	15	1601EA4	N8
		25	2701EA4	N8
	Feed-thru insert	15	1602A3R	N16
		25	2702A1	N16
		35	3702A1	N6, 16
	Insulated cap	15	160DR	N9
	Insulated cap with ground	15	160DRG	N9
		15	167DRG	N7, 9
		25	273DRG	N7, 9
		35	375DRG	N7, 9
	Insulated cap with ground and test point	15	168DRG	N7
		25	274DRG	N7
		35	376DRG	N7

**N4.** Also available as elbow with insert combination. Specify: 161A4-WX; 261A4-WX; 162A4-WX; 262A4-WX.

**N6.** Rated for single-phase applications only.

**N7.** Equipped with insulated cuff.

**N8.** Includes internal torquing feature using 200AT assembly tool.

**N9.** Also available without probe. Specify "A" suffix - Example: 273DRGA.

**N12.** Rated for 25 kV thru 35 kV applications.

**N16.** Fully rotatable for 360° positioning. Includes bail assembly to secure feed-thru insert to bushing well.

**N17.** Includes 02800X bi-metal contact.

**N20.** Includes a black vent ring.











**N22.** With stainless steel bracket.

Refer to the W and X tables on pages 84–85 for sizing to cable insulation diameter and conductor size. For cable shield adapters and jacket seals, see pages 74–75.

## 200 A loadbreak separable connectors

### Connectors and accessories

#### Connectors and accessories

Image (not to scale)	Description	Voltage class (kV)	Cat. no.	Notes
	Contacts: LR long bi-metal	All	Use Table X1 02500X	–
	ELR bi-metal	15/25	02509X	N1
	LR copper	All	02702X	N2
	LRT contact	15	02800X	–
	RLR contact	15/25	00400X	N3
	Elbow probe	15	166LRF	–
		35	375LRF	–
	Elbow cable entrance insulating plug	All	10EP-W Use Table W6	–
	Cable size adapter	15	160CA-W Use Table W6 EB-FA Only	N4
	Direct voltage test meter adapter for: HD electric meters	All	200TC-1	N14
	Ross meters	–	200TC-2	N14
	Chance meters	–	200TC-4	N14
	2-Way well junction with stainless steel bracket	15/25	K1601WJ2	N6
	2-Way well junction with “U” straps	15/25	K1601WJ2-5	N5, 6, 11
	3-Way well junction with stainless steel bracket	15/25	K1601WJ3	N6
	3-Way well junction with “U” straps	15/25	K1601WJ3-5	N5, 6, 12
	4-Way well junction with stainless steel bracket	15/25	K1601WJ4	N6
	4-Way well junction with “U” straps	15/25	K1601WJ4-5	N5, 6, 13
	2-Point junction with stainless steel bracket	15	164J2	N7
		25	274J2	N7
		35	373J2	N7
	2-Point junction with “U” straps	15	164J2-5	–
		25	274J2-5	N5, 8 N5, 11
		35	373J2-5	N5, 11
	3-Point junction with stainless steel bracket	15	164J3	N7
		25	274J3	N7
		35	373J3	N7
	3-Point junction with “U” straps	15	164J3-5	N5, 9
		25	274J3-5	N5, 12
		35	373J3-5	N5, 12
	4-Point junction with stainless steel bracket	15	164J4	N7
		25	274J4	N7
		35	373J4	N7
	4-Point junction with “U” straps	15	164J4-5	N5, 10
		25	274J4-5	N5, 13
		35	373J4-5	N5, 13

**N1.** Repair elbow has extended-length contact and elbow housing resulting in a net gain of 3¼" in length.

**N2.** Copper lug for use on COPPER CONDUCTOR ONLY.

**N3.** Replacement elbow has extended-length contact and elbow housing resulting in a net gain of 8¾" in length.

**N4.** 160CA cable size adapter can only be used with elbow catalog numbers 165LR/166LR C, H or CC size only.

**N5.** Also available as rubber only, without straps.

Specify suffix “-4” in place of “-5” in the catalog number.

**N6.** Supplied with replaceable stud. Replacement stud available separately. Specify 1000-150.

**N7.** Hardware packages, consisting of brackets and straps only, may be ordered separately by specifying “-6” in the catalog number. Example 164J4-6.

**N8.** Hardware package, consists of “U” straps and back plate only, may be ordered separately by specifying 1601US-J2.

**N9.** Hardware package, consists of “U” straps and back plate only, may be ordered separately by specifying 1601US-J3.

**N10.** Hardware package, consists of “U” straps and back plate only, may be ordered separately by specifying 1601US-J4.

**N11.** Hardware package, consists of “U” straps and back plate only, may be ordered separately by specifying 271-68.

**N12.** Hardware package, consists of “U” straps and back plate only, may be ordered separately by specifying 271-61.

**N13.** Hardware package, consists of “U” straps and back plate only, may be ordered separately by specifying 271-70.

**N14.** For use with direct test connectors.

Refer to the W and X tables on pages 84–85 for sizing to cable insulation diameter and conductor size. For cable shield adapters and jacket seals, see pages 74–75.



## Ordering information

The following diagram shows how to construct a catalog number for a 200-amp loadbreak elbow:

Indicates field that must be filled in to complete the catalog number.

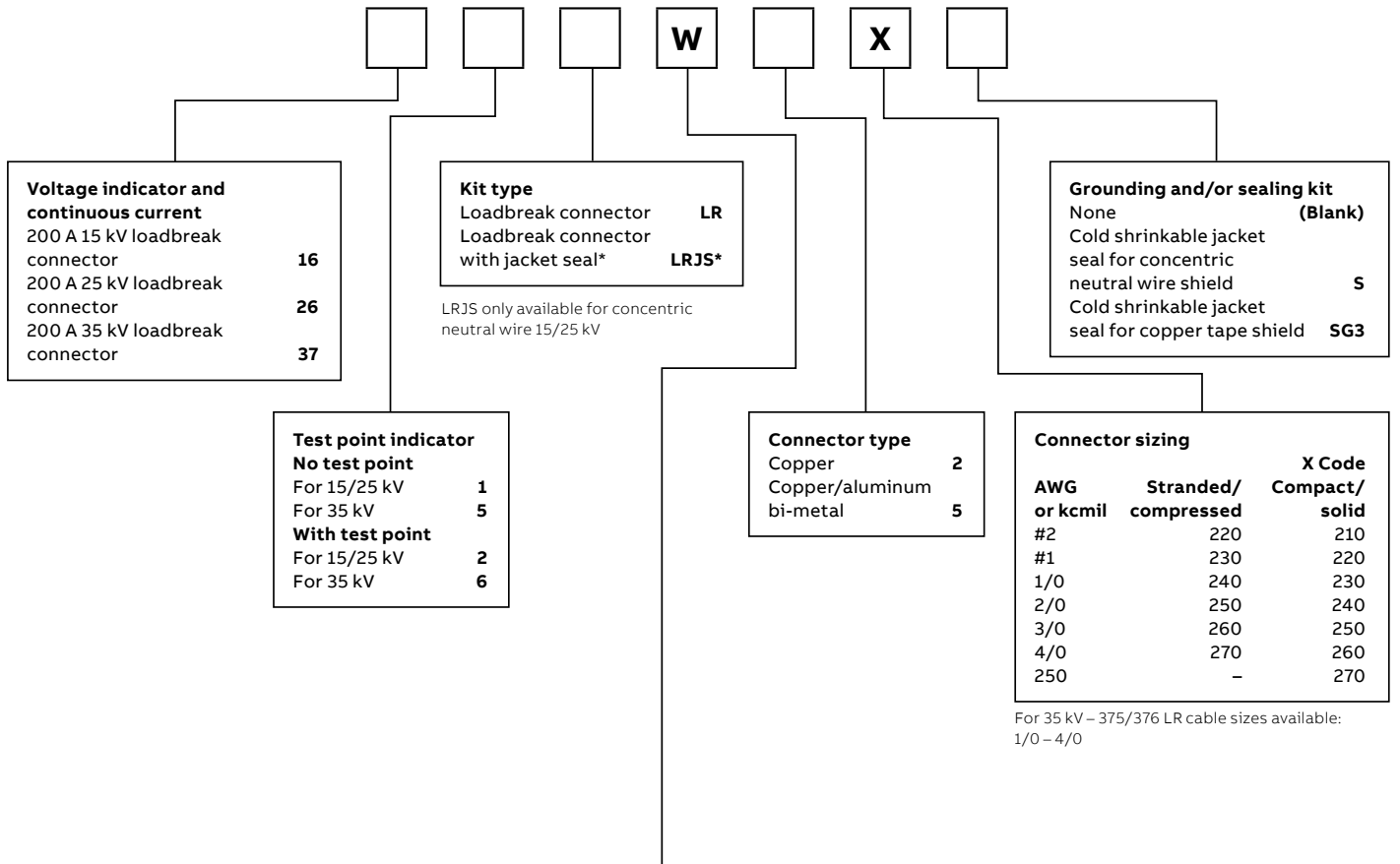

Table W1 – Elbow sizing 15/25 kV

Cable insulation diameter range				
Cable insulation diameter in in.		Cable insulation diameter in mm		Symbol for W
Min.	Max.	Min.	Max.	
0.575	0.740	14.6	18.7	A
0.635	0.905	16.1	22.9	B
0.805	1.060	20.4	26.9	C
0.890	1.220	22.6	30.9	D
1.090	1.310	27.6	33.2	E

Table W3 – Elbow sizing 35 kV

Cable insulation diameter range				
Cable insulation diameter in in.		Cable insulation diameter in mm		Symbol for W
Min.	Max.	Min.	Max.	
0.850	1.050	21.5	26.6	H
0.980	1.180	24.8	29.9	J
1.090	1.310	27.6	33.2	K
1.235	1.465	31.3	37.2	L

---

## 200 A deadbreak separable connectors

### Connectors and accessories

200 A deadbreak connectors and accessories provide a quick-disconnect feature for cable and equipment connections on power distribution systems.

All deadbreak connectors must be de-energized before operating and must be mechanically secured with bails when connected. Components can be isolated with insulated caps, plugs and parking bushings.

All deadbreak elbows are equipped with test points as standard. Optional accessories allow system grounding, bypass and lightning surge protection. Additional connecting points and taps can be provided by use of junctions or feed-thrus.

#### **Ratings overview**

See pages 4–5 for complete information.

#### **Current ratings**

- 200 A continuous
- 10 kA sym. 10 cycles

#### **Voltage ratings**

##### **15 kV class**

- 8.3 kV phase-to-ground
- 14.4 kV phase-to-phase
- 95 kV BIL
- 34 kV AC withstand
- 53 kV DC withstand
- 11 kV corona extinction

##### **25 kV class**

- 15.2 kV phase-to-ground
- 26.3 kV phase-to-phase
- 125 kV BIL
- 40 kV AC withstand
- 78 kV DC withstand
- 19 kV corona extinction

## 200 A deadbreak separable connector components

Cable to equipment

Operating accessories

Cable to cable connections

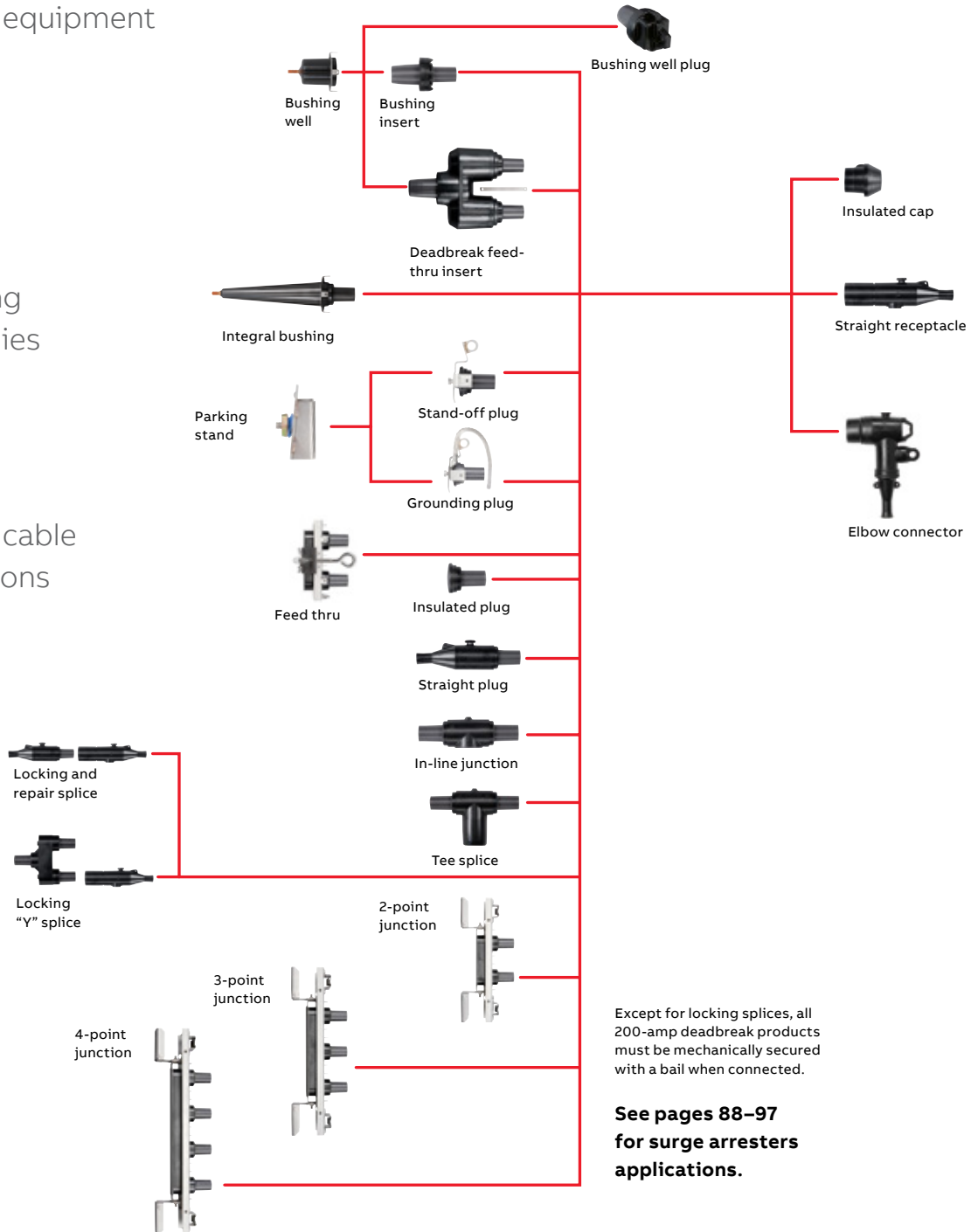

Except for locking splices, all 200-amp deadbreak products must be mechanically secured with a bail when connected.















**See pages 88–97 for surge arresters applications.**



## 200 A deadbreak separable connectors

### Connectors and accessories

#### 200 A deadbreak separable connectors

Image (not to scale)	Description	Voltage class (kV)	Cat. no.	Notes
	Elbow connector with test point	15/25	252LR-W0X Use tables W16 and X1	N1, 2
	Jacket seal elbow connector with test point	15/25	252LRJS-W5X Use tables W16 and X1	N2, 19
	Bail assembly for 156LR elbow	15/25	150BA	–
	Bushing insert	15/25	K1501A1	N3
	Feed-thru insert	15/25	K1502A1	N3, 4
	Insulated plug	15/25	K150DP	N3
	Insulated cap	15/25	K150DR	N3
	Insulated parking bushing	15/25	K151SOP	N3
	Grounding plug	15/25	151GP	N3
	Feed-thru	15/25	K1501FT	N3, 6
	2-point junction	15/25	K1501J2-U8	N3, 6
	3-point junction	15/25	K1501J3-U8	N3, 6
	4-point junction	15/25	K1501J4-U8	N3, 6
	Elbow probe	15/25	156LRF DP 0438609	–
	Straight receptacle	15/25	K151SR-W0X Use tables W1 and X1	N3, 12, 13, 17, 18
	Straight plug	15/25	K151SP-W0X Use tables W1 and X1	N3, 12, 13, 19

**N1.** Includes bail assembly.

**N2.** W5X indicates that the catalog number includes a 02500X bi-metal compression lug, which is rated for either aluminum or copper conductor, as standard. For an all-copper lug, replace W5X with W2X. Use Table X1 to specify the all-copper 02702X lug.

**N3.** Bails are required but not included. Order separately. Consult factory for bails not listed for a specific application.

**N4.** Fully rotatable for 360° positioning. Includes bail assembly to secure feed-thru insert to bushing well. Elbows bail assemblies are required but not included with the feed-thru insert.

**N6.** Center-to-center spacing equals 4 inches.

**N12.** Also available as housing only. Specify K151BSP-W or K151BSR-W.

**N13.** Also available in EB-FA sizes per Table W6 by using 160CA cable adapter with C size plugs and receptacles.

**N17.** Straight receptacles are also available with test point. Specify K152SR-W0X catalog number.















**N18.** W0X indicates that the catalog number includes a 01500X universal aluminum compression lug, which is rated for either aluminum or copper, as standard. For an all-copper lug, replace W0X with W2X in Table X1 to specify the all-copper 01502X lug.

**N19.** W0X indicates that the catalog number includes a 01600X universal aluminum compression lug, which is rated for either aluminum or copper, as standard. For an all-copper lug, replace W0X with W2X in Table X1 to specify the all-copper 01602X lug.

**N22.** Direct test connectors, along with a 200TC-X series meter adapter, a properly rated voltage meter and hot-line stick provides a means for direct conductor voltage testing. See page 12 for meter adapters.

Refer to the W and X tables on pages 84–85 for sizing to cable insulation diameter and conductor size. For cable shield adapters and jacket seals, see pages 74–75.

## 200 A deadbreak connectors and accessories

Image (not to scale)	Description	Voltage class (kV)	Cat. no.	Notes
	Tee splice	15/25	K150T	N3
	In-line junction	15/25	K150S	N3
	Locking splice/ repair splice	15/25	K151LS-WOX Use tables W1 and X1	N8, 9, 13, 15, 16, 17, 20, 23
	Locking "Y" splice	15/25	K151LY-WOX Use tables W1 and X1	N8, 9, 13, 15, 17, 21
	Bail	15/25	150TB1	N5
	Bail	15/25	150TB2	N5
	Bail	15/25	150TB3	N5
	Bail	15/25	150TB4	N5
	Bail	15/25	150TB5	N5
	Bail	15/25	150TB6	N5
	Contacts: long bi-metal copper	15/25 15/25	02500X 02702X	N7
	Elbow cable entrance insulating plug	15/25	10EP-W Use table W6	N10
	Cable entrance insulating plug	15/25	152EA-W Use table W6	N11
	Cable size adapter	15/25	160CA-W Use table W6 EB-FA only	N14

**N3.** Bails are required but not included. Order separately. Consult factory for bails not listed for a specific application.

**N5.** Refer to factory for application details.

**N7.** Copper lug for copper cable only.

**N8.** To order cable legs for different cable sizes, list each leg size "W" and "X". Example: K151LY-A1240-A1240-B1220. See Tables W1 and X1 for sizes.

**N9.** To order locking contacts for K151LS and K151LY, order 01401X (Al) or 01402X (Cu) for plug contact. Order 01301X (Al) or 01302X (Cu) for receptacle. See Table X1 for sizes.

**N10.** For use with 156LR elbows.

**N11.** For use with K151SR, K151SP, K151LS, K151LY receptacles, plugs and splices.

**N13.** Also available in EB-FA sizes per Table W6 by using 160CA cable adapter with C size plugs and receptacles.

**N14.** 160CA cable adapter can only be used with C size plugs and receptacles.

**N15.** Bails are not required for locking splices.

**N16.** When used as a repair splice, the assembled length allows 4" for cable replacement/repair.

**N17.** Straight receptacles are also available with test point. Specify K152SR-WOX catalog number.

**N20.** WOX indicates that the catalog number includes a 01400X universal aluminum compression lug, which is rated for either aluminum or copper, as standard. For an all-copper lug, replace WOX with W2X in Table X1 to specify the all-copper 01402X lug.

**N21.** WOX indicates that the catalog number includes a 01300X universal aluminum compression lug, which is rated for either aluminum or copper, as standard. For an all-copper lug, replace WOX with W2X in Table X1 to specify the all-copper 01302X lug.

**N23.** Gains approximately 4" of repair length.

Refer to the W and X tables on pages 84–85 for sizing to cable insulation diameter and conductor size. For cable shield adapters and jacket seals, see pages 74–75.

## 200 A deadbreak separable connectors

### 15/25 kV deadbreak elbow connectors ordering information

The following diagram shows how to construct a catalog number for a 200 A deadbreak elbow connector:

Indicates field that must be filled in to complete the catalog number.

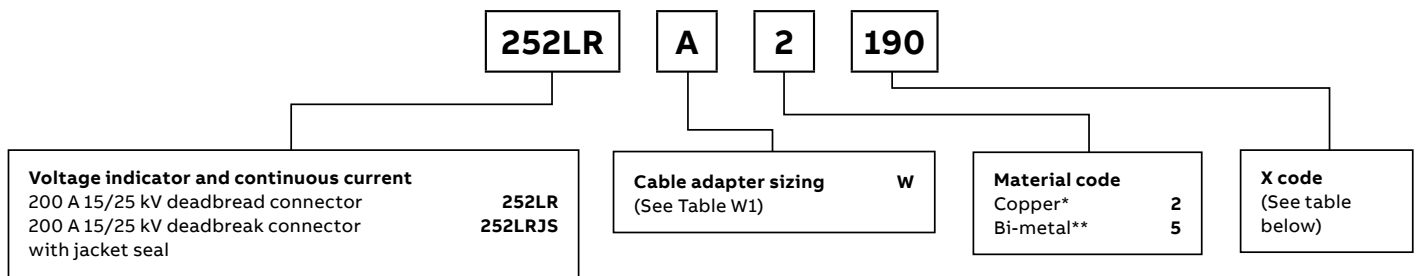

Table W1 – Cable insulation dia. range

Inches		mm		Symbol for W
Min.	Max.	Min.	Max.	
0.575	0.74	14.61	18.8	A
0.635	0.905	16.13	22.99	B
0.805	1.06	20.45	26.92	C
0.89	1.22	22.61	30.99	D
1.09	1.31	27.48	33.27	E

X code

Conductor size AWG or kcmil		Connector only			X code
Stranded/compressed	Solid/compact	mm <sup>2</sup>	Bi-metal**	Copper*	
-	#4	16.76	02500190	02702190	190
#4	#3	21.14	02500200	02702200	200
#3	#2	26.67	02500210	02702210	210
#2	#1	33.62	02500220	02702220	220
#1	1/0	42.41	02500230	02702230	230
1/0	2/0	53.49	02500240	02702240	240
2/0	3/0	67.43	02500250	02702250	250
3/0	4/0	85.01	02500260	02702260	260
4/0	250	107.2	02500270	02702270	270

\* Copper compression lug suitable for all copper conductors only.

\*\* Bi-metal compression lug with universal aluminum barrel suitable for copper or aluminum conductors.

## 600 A deadbreak separable connectors

### 600 series deadbreak components

600 Series deadbreak elbows, straight receptacles, junctions, vault stretchers and accessories are used to connect equipment and cable on primary feeder and network circuits. Designs accommodate large conductors and feature bolted connections and deadfront modular construction for maximum reliability, performance and versatility. De-energized connectors can be quickly and easily connected and disconnected using standard hand tools and equipment in accordance with accepted operating practices. Optional accessories allow visible external separation, bypass, isolation, dead-ending, grounding and testing as well as adding taps, surge arresters and circuit protection. Hotstick-operable and separable joint systems are shown on pages 28–34 and 49–52.

#### Spiking aid

When spiking a medium voltage cable near a separable connector, the Elastimold® spiking aid is a specially designed product to reduce outage time and cost. Medium voltage cable is spiked as a means to ensure the circuit is de-energized where there is no sectionalizing device, direct testing means or provision for grounding.

#### Veri-Spike™ Grounding-aid device

The Elastimold Veri-Spike grounding-aid device is designed to provide a safe and quick method to verify that a system is de-energized before any maintenance begins. The Veri-Spike device consists of a sacrificial cap and a connecting plug that installs easily in place of a basic insulating plug. Once installed, the replaceable sacrificial cap can either be cut or spiked to verify that the system is de-energized and replaced with a grounding ball to properly ground the system.

#### GAD

When available fault currents exceed 10 kA in underground systems, the Elastimold GAD may provide a solution. The Elastimold GAD is rated 25 kA and installs in the rear interface of a 600 series elbow connector (T-body). The GAD is normally covered and insulated with an insulating cap that contains capacitive test and a hotstick operating band. Once the circuit is opened at a disconnecting device, the test point cap is removed with a hotstick, and then using an appropriate capacitive test point meter, the test point is checked for voltage. The insulating cap is then removed with a hotstick and a high voltage meter is used to confirm the de-energized state before a ground cable is connected.

# 600 A deadbreak separable connectors

## 600 series deadbreak components

- \* Tested at 8.3/14.9 kV
- † Tested at 15.2/26.3 kV
- Tested at 21.1/36.6 kV

### Cable to equipment

See pages 88–97 for surge arrester applications.



Integral bushing

### Cable to cable (using junctions)

See pages 53–56 for additional junctions

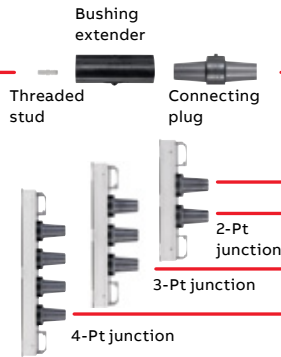

### Operating accessories

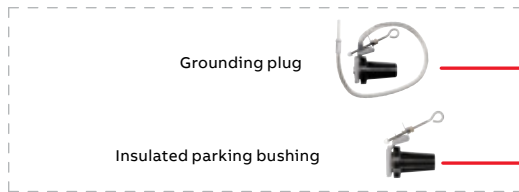

### Straight receptacle

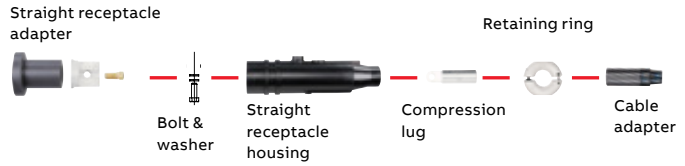

### Elbow connector

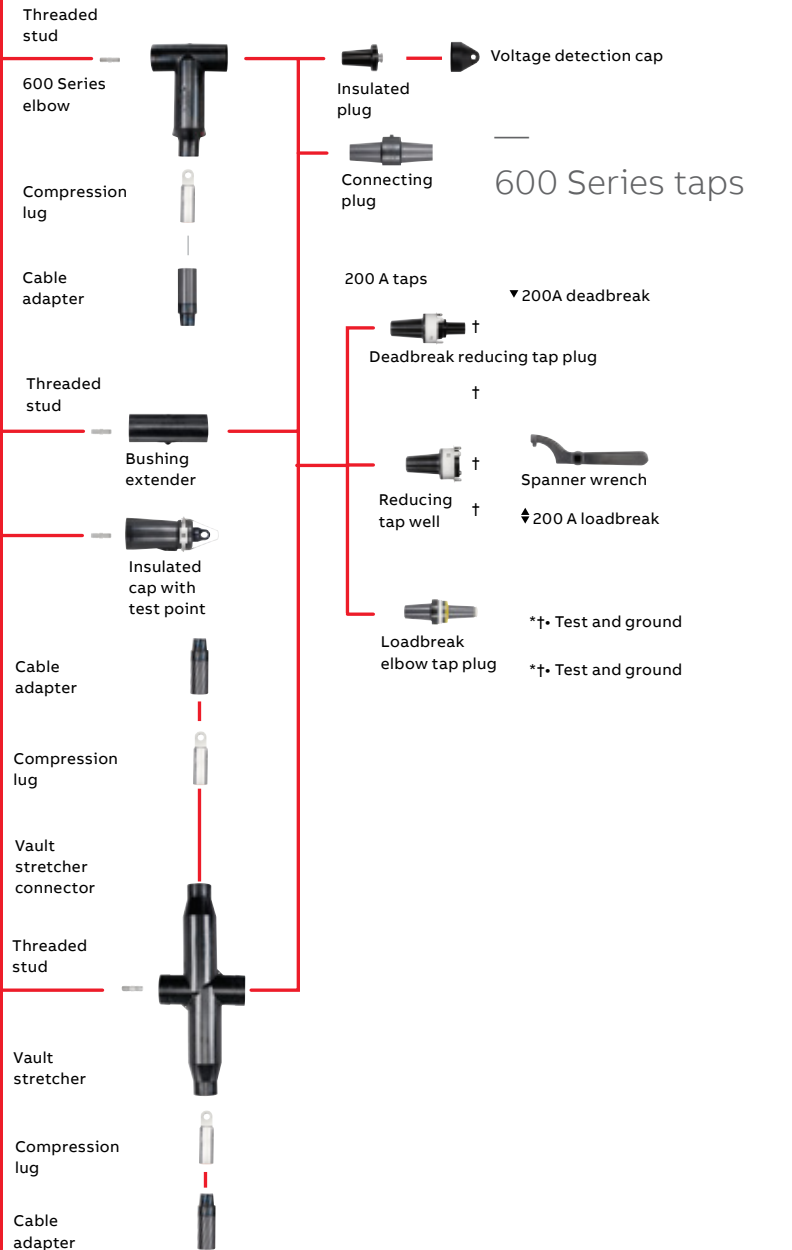

### 600 Series taps











▼ 200A deadbreak

Spanner wrench  
◆ 200 A loadbreak

\*†• Test and ground  
\*†• Test and ground



## 600 A deadbreak elbows

Image (not to scale)	Description	Voltage class (kV)	Cat. no.	Notes
	600 Series elbow (with insulating plug, cap, stud, lug and cable adapter)	15/25	K655LR-W0X Use tables W7 and X6	N1, 2
		35	755LR-W0X Use tables W9 and X6	N1, 2, 15
	600 Series direct test elbow (with insulating plug, cap, stud lug and cable adapter)	15/25	K655DLR-W0X Use tables W7 and X6	N1, 2, 12
		35	755DLR-W0X Use tables W9 and X6	N1, 2, 12, 15
	600 Series elbow with test point (with insulating plug, cap, stud, lug and cable adapter)	15/25	K656LR-W0X Use tables W7 and X6	N1, 2
		35	756LR-W0X Use tables W9 and X6	N1, 2, 15
	600 Series direct test elbow with test point (with insulating plug, cap, stud, lug and cable adapter)	15/25	K656DLR-W0X Use tables W7 and X6	N1, 2, 12
		35	756DLR-W0X Use tables W9 and X6	N1, 2, 12, 15
	600 Series elbow without test point housing only (with stud)	15/25	K655BLR	N1, 3
		35	755BLR	N1, 3, 15
	600 Series elbow with test point housing only (with stud)	15/25	K656BLR	N1, 3
		35	756BLR	N1, 3, 15
	600 Series straight receptacle (with cable adapter, lug and retaining ring)	15/25	K655SR-W0X Use tables W7 and X6	N1, 2, 11
	600 Series direct test straight receptacle elbow	15/25	K655DSR-W0X Use tables W7 and X6	N1, 2, 11, 12
	600 Series straight receptacle housing (lug and cable adapter not included)	15/25	K655BSR	N1,11
	Straight receptacle adapter	15/25	K650SRA	N1, 4
	600 Series vault stretcher (housing only with stud)	15/25 kV	K655BVS	N1, 9
		35 kV	755BVS	N1, 9

**N1.** For 900 A ratings, substitute 675 for 650 and 655; 676 for 656; K671 for K651; K675 for K650 and K655; K676 for K656; 775 for 750 and 755; 776 for 756 and 2X for 0X in the catalog number. The 900 A rating requires copper current-carrying connector components and copper conductor cable.

**N2.** Add suffix symbol from page 75 to include cable shield grounding kit and/or cable jacket sealing kit.

**N3.** Available without the stud by adding "N" to the catalog number.

**N4.** Straight receptacle adapter is used to connect straight receptacles K655YBSR and K655YSR-W0X ( 50) to equipment bushings.

**N5.** Aluminum lug for use on aluminum or copper conductors. DO NOT substitute threaded 03600X lug.

**N6.** Copper lug for use on COPPER CONDUCTOR ONLY.

DO NOT substitute threaded 03602X lug.

**N7.** Available with the stud factory-assembled by adding "SP" to the catalog number. 675ETP, K675ETP and 775ETP are available as -SP only. The stud is not field removable.

**N8.** Available with a loose stud by adding suffix "S" to the catalog number.

**N9.** 600SW spanner wrench is recommended for installation of deadbreak reducing tap plugs and reducing tap wells.

**N10.** Use 600ATM assembly tool.

**N11.** 600 Series elbows and straight receptacles with IEEE Std. 386 capacitive test points are available by substituting 656 for 655; K656 for K655; K676 for K675; 756 for 755; 676 for 675; K676 for K675 and 776 for 775 in the catalog number.

**N12.** Direct test connectors, along with a 200TC-X series meter adapter, a properly rated voltage meter and hot-line stick; provides a means for direct conductor voltage testing.

**N13.** With stainless steel bracket.

**N15.** Available with 200 kV BIL adding suffix "-200".























**N16.** Bimetallic Lug for use on aluminum or copper conductors. DO NOT substitute threaded 05501X lug

Refer to the W and X tables on pages 84–85 for sizing to cable insulation diameter and conductor size. For cable shield adapters and jacket seals, see pages 74–75.

## 600 A deadbreak separable connectors

### 600 series deadbreak components

#### 600 A deadbreak accessories

Image (not to scale)	Description	Voltage class (kV)	Cat. no.	Notes
	Cable size adapter	15/25	655CA-W Use tables W7	–
		35	755CA-W Use tables W9	–
	Compression lug	All	03700X Use tables X6	N5
		All	03702X Use tables X6	N6
	Bimetallic compression lug	All	04601XXX Use Table X6	N16
	Epoxy connecting plug	15/25	K650CP	N9
	600 Series elbow and vault stretcher size sensitive kit (cable adapter and lug)	15/25	655CK-W0X Use tables W7 and X6	N2
		35	755CK-W0X Use tables W9 and X6	N2
	Adapter retaining ring	All	650ARR-X Use Table X6	–
	600 Series straight receptacle size sensitive kit (cable adapter, retaining ring and lug)	15/25	655CK-W0X-ARR Use tables W7 and X6	N2
	Bushing extender (with stud)	15/25	K655BE	N1, 3
		35	755BE	N1, 3
	Insulated cap with test point (with stud)	15/25	K656DR	N3, 7
		35	756DR	–
	Insulated cap with test point (with stud) and ground	15/25	K656DRG	N3, 7
		35	756DRG	–
	Insulating plug (with cap)	15/25	K650BIP	N1, 7, 8
		35	750BIP	N1, 7, 8
	Grounding plug (ground lead 2/0 AWG x 30")	15/25	650GP	N1, 7, 8
		35	750GP	N1, 7, 8
	Insulated parking bushing	15/25	K650SOP	N7, 8
		35	750SOP	N7, 8
	Connecting plug	15/25	K651CP	N1, 7, 8, 10
		35	750CP	N1, 7, 8, 10
	Deadbreak reducing tap plug	15/25	K650RTP	N1, 7, 8, 9
	Reducing tap well	15/25	K650RTW	N1, 7, 8, 9
	Loadbreak elbow tap plug	15	650ETP	N1, 7, 8, 10
		25	K650ETP	N1, 7, 8, 10
		35	750ETP	N1, 7, 8, 10
	Vault stretcher threaded stud	15/25	650VSA	N1
		35	750VSA	N1
	600 Series elbow threaded stud	15/25	650SA	N1
		35	750SA	N1
	Assembly tool (window-op)	All	600ATM	–
	Spanner wrench	All	600SW	N9
	Direct voltage test meter adapter for: HD electric meters	All	200TC-1	N12
	Ross meters		200TC-2	N12
	Chance meters		200TC-4	N12

**N1.** For 900 A ratings, substitute 675 for 650 and 655; 676 for 656; K671 for K651; K675 for K650 and K655; K676 for K656; 775 for 750 and 755; 776 for 756 and 2X for 0X in the catalog number. The 900 A rating requires copper current-carrying connector components and copper conductor cable.

**N2.** Add suffix symbol from page 75 to include cable shield grounding kit and/or cable jacket sealing kit.

**N3.** Available without the stud by adding "N" to the catalog number.

**N4.** Straight receptacle adapter is used to connect straight receptacles K655YBSR and K655YSR-W0X (50) to equipment bushings.

**N5.** Aluminum lug for use on aluminum or copper conductors. DO NOT substitute threaded 03600X lug.

**N6.** Copper lug for use on COPPER CONDUCTOR ONLY. DO NOT substitute threaded 03602X lug.

**N7.** Available with the stud factory-assembled by adding "SP" to the catalog number. 675ETP, K675ETP and 775ETP are available as -SP only.

The stud is not field removable.

**N8.** Available with a loose stud by adding suffix "S" to the catalog number.

**N9.** 600SW spanner wrench is recommended for installation of deadbreak reducing tap plugs and reducing tap wells.

**N10.** Use 600ATM assembly tool.

**N11.** 600 Series elbows and straight receptacles with IEEE Std. 386 capacitive test points are available by substituting 656 for 655; K656 for K655; K676 for K675; 756 for 755; 676 for 675; K676 for K675 and 776 for 775 in the catalog number.

**N12.** Direct test connectors, along with a 200TC-X series meter adapter, a properly rated voltage meter and hot-line stick; provides a means for direct conductor voltage testing.

**N13.** With stainless steel bracket.

**N15.** Available with 200 kV BIL adding suffix "-200".

**N16.** Bimetallic lug for use on aluminum or copper conductors. DO NOT substitute threaded 05501X lug.

Refer to the W and X tables on pages 84–85 for sizing to cable insulation diameter and conductor size. For cable shield adapters and jacket seals, see pages 74–75.

## Ordering information

The following diagram shows how to construct a catalog number for a 600 A deadbreak elbow connector:

Indicates field that must be filled in to complete the catalog number.

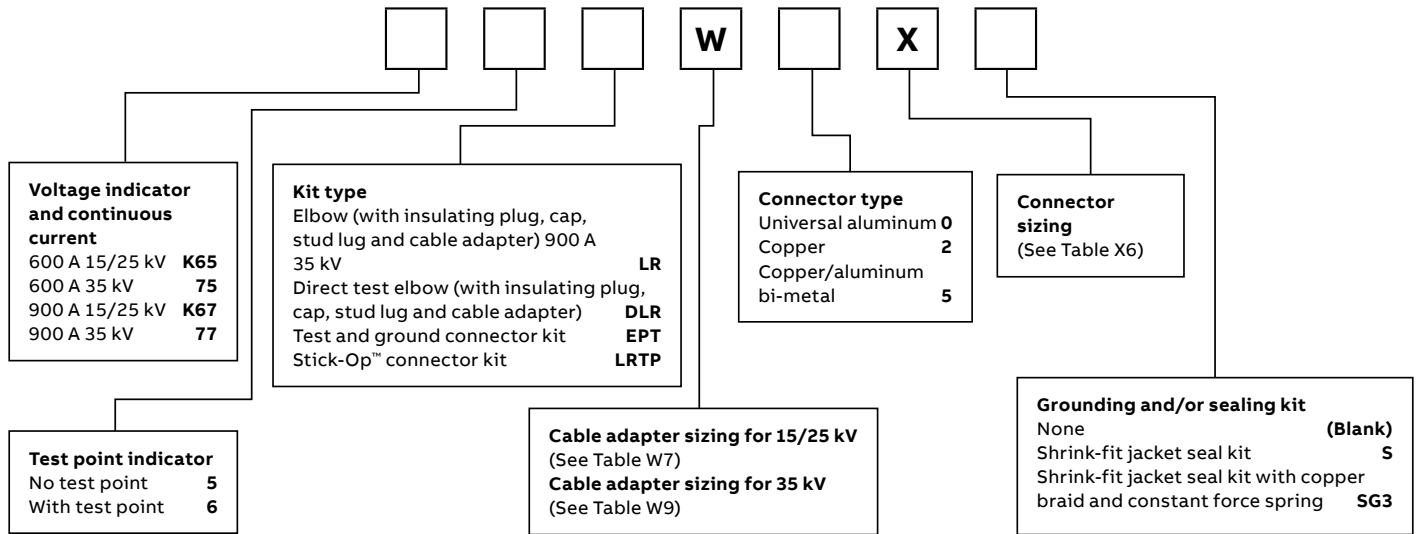

Table W7 – Cable adapter sizing for 15/25 kV

Cable insulation dia. range				
Cable insulation diameter in inches		Cable insulation diameter in millimeters		Symbol for W
Min.	Max.	Min.	Max.	
0.420	0.660	10.7	16.8	D
0.530	0.680	13.5	17.3	E
0.640	0.820	16.3	20.8	F
0.760	0.950	19.3	24.1	G
0.850	1.050	21.6	26.7	H
0.980	1.180	24.9	4.6	J
1.090	1.310	27.7	33.3	K
1.180	1.465	30.0	37.2	L
1.280	1.430	32.5	36.3	LM
1.370	1.630	34.8	41.4	M
1.550	1.780	39.4	45.2	N
1.725	1.935	43.8	49.1	P

Table W9 – Cable adapter sizing for 35 kV

Cable insulation dia. range				
Cable insulation diameter in inches		Cable insulation diameter in millimeters		Symbol for W
Min.	Max.	Min.	Max.	
0.760	0.950	19.3	24.1	G
0.850	1.050	21.6	26.7	H
0.980	1.180	24.9	30.0	J
1.090	1.310	27.7	33.3	K
1.180	1.465	30.0	37.2	L
1.370	1.630	34.8	41.4	M
1.515	1.780	38.5	45.2	N
1.725	1.935	43.8	49.1	P
1.900	2.120	48.3	53.8	Q
2.115	2.235	53.7	56.8	R

Table X6 – Connector sizing

AWG or kcmil		
Stranded/compressed	Solid/compact	X Code
-	#2	210
#2	#1	220
#1	1/0	230
1/0	2/0	240
2/0	3/0	250
3/0	4/0	260
4/0	250	270
250	300	280
300	350	290
350	400	300
400	450	310
450	500/550	320
500	600	330
550	650	340
600	700	350
650	750/800	360
700/750	900	380
800	-	390
900	1000	400
1000	-	410
-	1250	420
1250	-	440

## 600 A deadbreak elbow separable connectors

### 600 series deadbreak components

600 series deadbreak elbows, straight receptacles, junctions, vault stretchers and accessories are used to connect equipment and cable on primary feeder and network circuits. Designs accommodate large conductors and feature bolted connections and deadfront modular construction for maximum reliability, performance and versatility.

De-energized connectors can be quickly and easily connected and disconnected using standard hand tools and equipment in accordance with accepted operating practices. Optional accessories allow visible external separation, bypass, isolation, dead-ending, grounding and testing as well as adding taps, surge arresters and circuit protection.

Hotstick operable and separable joint systems are shown on pages 28–34 and 49–52.

Elastimold® junctions are designed for subsurface, vault or padmount applications and can be used for sectionalizing, looping, tapping and equipment bypass. Junctions are designed to mate with other Elastimold products including:

- K655 elbow connector
- K655BE bushing extender
- 655BEA3 bushing adapter

Elastimold junctions are equipped with a stainless steel mounting bracket and back plate suitable for mounting on a flat surface.

### Features

- 15/25 kV and 35 kV, 600 A deadbreak
- 2-Way, 3-way and 4-way junctions
- 200 kV BIL is available for the 35 kV products
- Fully shielded, fully submersible molded rubber housing
- Stainless steel mounting bracket



### Ratings overview

See 4–5 for complete information.

#### Current ratings

**(Prefixes: 650, K650, K651, K655, K656, 750, 755, 756 and 03700)**

- 600 A continuous
- 25 kA sym., 10 cycles

**(Prefixes 675, K675, K671, K676, 775, 776 and 03702)**

- 900 A continuous
- 25 kA sym., 10 cycles

Note: 900 A ratings require copper cable and copper current-carrying components.

#### Voltage ratings

**15/25 kV class (5 kV through 28 kV)**

- 16.2 kV phase-to-ground
- 28 kV phase-to-phase
- 140 kV BIL
- 45 kV AC withstand
- 84 kV DC withstand
- 21.5 kV corona extinction

**35 kV class**

- 21.1 kV phase-to-ground
- 36.6 kV phase-to-phase
- 150 kV BIL
- 50 kV AC withstand
- 103 kV DC withstand
- 26 kV corona extinction

Note: Elastimold has increased the IEEE Standard Production and Design Test levels for 25 kV class products to include 27 kV and 28 kV systems.

\* Tested @ 8.3/14.9 kV

† Tested @ 15.2/26.3 kV

• Tested @ 21.1/36.6 kV

# Separable connectors 600 series deadbreak

See pages 88-97 for surge arrester applications.

Cable to equipment

Cable to cable (using junctions)

Operating accessories

Hotstick operable 600 series connectors See pages 28-34

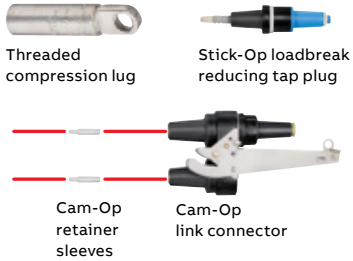

Straight receptacle

Elbow connector

600 Series taps

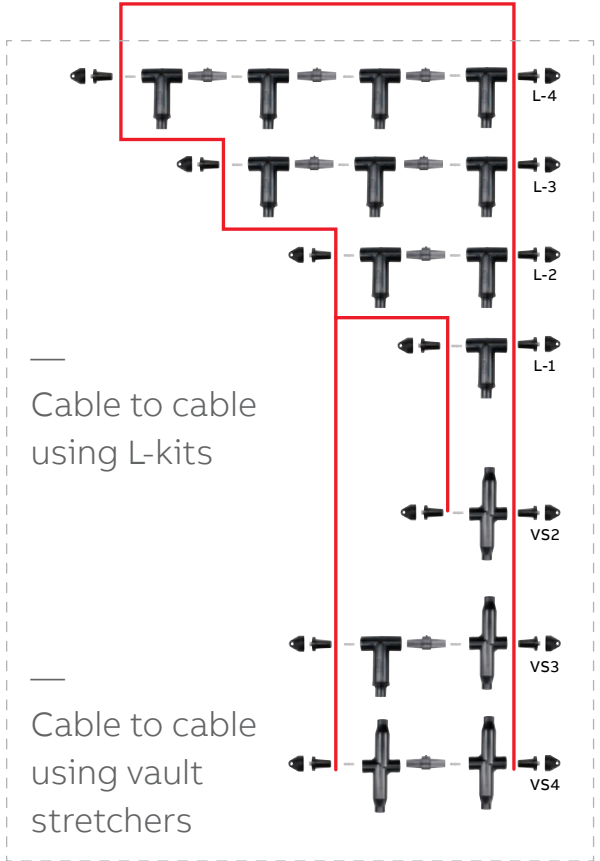













## 600 A deadbreak elbow separable connectors

### 600 series deadbreak components

#### 600 series deadbreak components

Image (not to scale)	Description	Voltage class (kV)	Cat. no.	Notes
	2-point junction	15/25 35	K650J2 750J2	N1, 7, 8 N1, 7, 8, 11
	3-point junction	15/25 35	K650J3 750J3	N1, 7, 8 N1, 7, 8, 11
	4-point junction	15/25 35	K650J4 750J4	N1, 7, 8 N1, 7, 8, 11
	1-way L-kit	15/25 35	K655L1 755L1	N1, 2, 3, 9, 10 N1, 2, 3, 11
	2-way L-kit	15/25 35	K655L2-WOX 755L2-WOX	N1, 2, 3, 4, 5, 6, 9, 10 N1, 2, 3, 4, 5, 6, 11
	2-way VS-kit	15/25 kV 35 kV	K655VSL2-WOX 755VSL2-WOX	N1, 2, 3, 9, 10 N1, 2, 3, 11
	3-way L-kit	15/25 35	K655L3-WOX 755L3-WOX	N1, 2, 3, 4, 9, 10 N1, 2, 3, 4, 11
	3-way VS kit	15/25 35	K655VSL3-WOX 755VSL3-WOX	N1, 2, 3, 5, 6, 9, 10 N1, 2, 3, 5, 6, 11
	4-way L-kit	15/25 35	K655L4-WOX 755L4-WOX	N1, 2, 3, 4, 9, 10 N1, 2, 3, 4, 11
	4-way VS-kit	15/25 35	K655VSL4-WOX 755VSL4-WOX	N1, 2, 3, 5, 6, 9, 10 N1, 2, 3, 5, 6, 11
	Assembly tool	All	600ATM	-

- N1.** For 900 A ratings, substitute 675 for 650 and 655; 676 for 656; K675 for K650 and K655; K676 for K656; 775 for 750 and 755; 776 for 756 and 2X for 0X in the catalog number. The 900 A rating requires copper current-carrying connector components and copper conductor cable.
- N2.** L-Kits and VS-Kits do not include cable adapters or compression lugs. These items must be ordered separately.
- N3.** 600 Series Elbows and Straight Receptacles with IEEE Std. 386 capacitive test points are available by substituting 656 for 655; K656 for K655; K676 for K675; 756 for 755; 676 for 675; K676 for K675 and 776 for 775 in the catalog number.
- N4.** 600ATM is recommended for installing K651CP and 750CP.
- N5.** Can be used as a repair joint mounting hardware. (Gains 3/8" of repair length.)
- N6.** Can be used as a reducing joint for different size cables.
- N7.** Rubber junction with stainless steel mounting plate and back plate. Add "-U" for rubber junction with stainless steel mounting plate, back plate and adjustable mounting bracket. Add "-4" for rubber junction only. Add "-5" for rubber junction, stainless steel U-straps and back plate. Add "-6" Hardware package consists of brackets and straps only.
- N8.** Two - six-position multi-point junctions shown on pages 22–23.
- N9.** Replace "L" for "E" when connecting to equipment and one BIP is not required (i.e., K655E2, K655E3, K655VSE3).
- N10.** Add "G" after "L" to replace a BIP with a GAD + GADDR or "GB" for a BGAD+BGADDR (i.e., K655EG2, K655LGB3, K655VSEG3).
- N11.** Available with 200 kV BIL adding suffix "-200".

Refer to the next for L-kits and vault stretcher kits ordering information.

## L-kits and vault stretcher kits ordering information

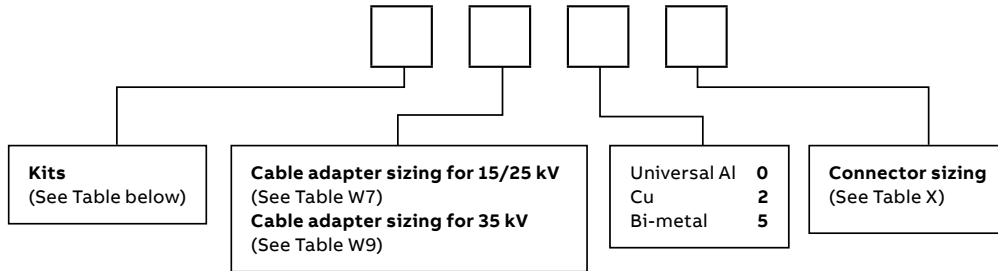

**Kits**

Kits	15/25 kV	35 kV
1-way L-kit	K655L1	755L1
2-way L-kit	K655L2	755L2
3-way L-kit	K655L3	755L3
4-way L-kit	K655L4	755L4
2-way VS-kit	K655VSL2	755VSL2
3-way VS-kit	K655VSL3	755VSL3
4-way VS-kit	K655VSL4	755VSL4

**Table W7 – Cable adapter sizing for 15/25 kV**

For 15/25 kV					
Cable insulation diameter in inches		Cable insulation diameter in millimeters		Symbol for W	
Min.	Max.	Min.	Max.		
0.640	0.820	16.256	20.828	F	
0.760	0.950	19.304	24.130	G	
0.850	1.050	21.590	26.670	H	
0.980	1.180	24.892	29.972	J	
1.090	1.310	27.686	33.274	K	
1.180	1.465	29.972	37.211	L	
1.280	1.430	32.512	36.322	LM	
1.370	1.630	34.798	41.402	M	
1.550	1.780	38.481	45.212	N	
1.725	1.935	43.815	49.149	P	

**Table W9 – Cable adapter sizing for 35 kV**

For 35 kV					
Cable insulation diameter in inches		Cable insulation diameter in millimeters		Symbol for W	
Min.	Max.	Min.	Max.		
0.760	0.950	19.304	24.130	G	
0.850	1.050	21.590	26.670	H	
0.980	1.180	24.892	29.972	J	
1.090	1.310	27.686	33.274	K	
1.180	1.465	29.972	37.211	L	
1.280	1.430	32.512	36.322	LM	
1.370	1.630	34.798	41.402	M	
1.550	1.780	38.481	45.212	N	
1.725	1.935	43.815	49.149	P	
1.900	2.120	48.260	53.848	Q	

**Table X – Connector sizing**

	AWG or kcmil		mm <sup>2</sup>		Connector only		
	Strand./compr.	Solid/compact	Compact	Universal aluminum	Copper	Bi-metal	
210	-	2	-	03700210	03702210	04601210	
220	2	1	35	03700220	03702220	04601220	
230	1	1/0	50	03700230	03702230	04601230	
240	1/0	2/0	-	03700240	03702240	04601240	
250	2/0	3/0	70	03700250	03702250	04601250	
260	3/0	4/0	95	03700260	03702260	04601260	
270	4/0	250	125	03700270	03702270	04601270	
280	250	300	-	03700280	03702280	04601280	
290	300	350	150	03700290	03702290	04601290	
300	350	400	185	03700300	03702300	04601300	
310	400	450	240	03700310	03702310	04601310	
320	450	500/550	-	03700320	03702320	04601320	
330	500	600	250/300	03700330	03702330	04601330	
340	550	650	-	03700340	03702340	04601340	
350	600	700	400	03700350	03702350	03705350	
360	650	750/800	-	03700360	03702360	04601360	
380	700/750	900	-	03700380	03702380	04601380	
390	800	-	500	03700390	03702390	04601390	
400	900	1000	-	03700410	03702410	04601410	
410	1000	-	-	03700410	03702410	04601410	
420	-	1250	-	03700420	03702420	04601420	
440	1250	-	-	03700440	03702440	04600440	

## 600 A deadbreak elbow separable connectors

### 600 series Cam-Op™ deadbreak connector system

The Elastimold® 600 series Cam-Op deadbreak connector system incorporates provisions for hotstick operation of de-energized primary feeder or network circuits. Configurations allow external visible break, testing, grounding and isolation. Retrofit kits allow upgrading existing equipment.

The Cam-Op system utilizes pin and socket connectors and can be retrofitted to existing equipment. The Cam-Op connector is easily installed or removed by hotstick operation of the cam-action disconnect lever.

#### Features

- 15/25 and 35 kV, 600 A deadbreak-rated Cam-Op link
- Provides 200 A tap for testing and grounding connections
- Cam-Op lever for hotstick operation and easy installation and removal
- Visi-Break series provides for independent isolation of circuits

#### Ratings overview

See pages 4–5 for complete information.

##### Current ratings

600 A and 900 A continuous  
25 kA sym., 10 cycles

Note: 900 A ratings require copper cable and copper current-carrying components.

##### Continuous voltage ratings

###### 15 kV class

- 8.3 kV phase-to-ground
- 14.4 kV phase-to-phase
- 95 kV BIL
- 34 kV AC withstand
- 53 kV DC withstand
- 11 kV corona extinction

###### 25 kV class

- 15.2 kV phase-to-ground
- 26.3 kV phase-to-phase
- 125 kV BIL
- 40 kV AC withstand
- 78 kV DC withstand
- 19 kV corona extinction

###### 35 kV class

- 21.1 kV phase-to-ground
- 36.6 kV phase-to-phase
- 150 kV BIL
- 50 kV AC withstand
- 103 kV DC withstand
- 26 kV corona extinction





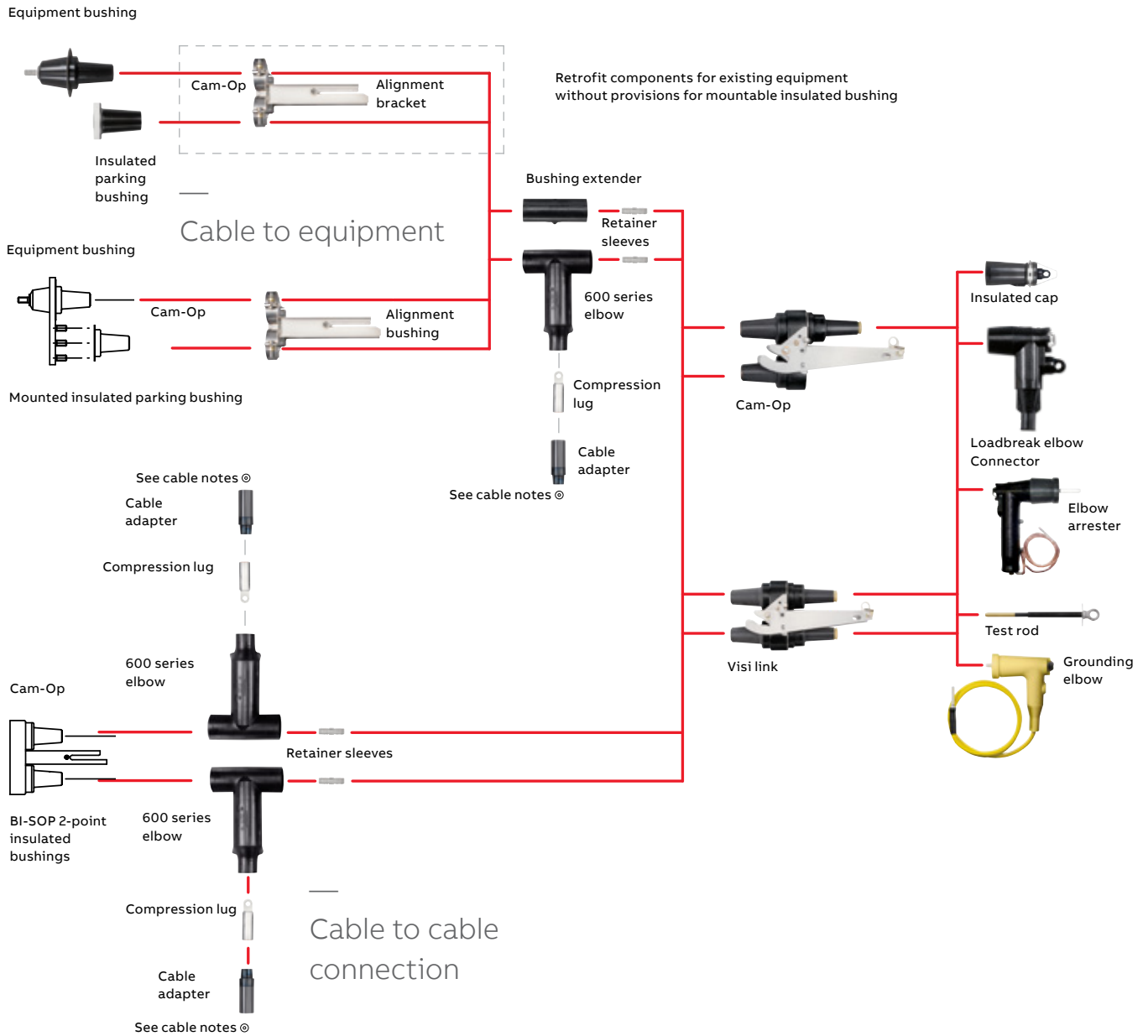









# Cam-Op™ system – 600 series deadbreak



## 600 A deadbreak elbow separable connectors

### 600 series Cam-Op™ deadbreak connector system

#### 600 series Cam-Op system

Image (not to scale)	Description	Voltage class (kV)	Cat. no.	Notes
	Cam-Op connector kit	15	655LINK-C-LR-W0X-B-DRG Use tables W7 and X6	N1, 2, 8, 10, 11, 12
		25	K655LINK-C-LR-W0X-B-DRG Use tables W7 and X6	N1, 2, 8, 10, 11, 12
		35	755LINK-C-LR-W0X-B-DRG Use tables W9 and X6	N1, 2, 8, 10, 11, 12
	Mountable insulated bushing	25	K650LBM-3	N2
		35	750LBM-3	N2
	Retrofit Cam-Op connector kit	15	655LINK-C-LR-W0X-A-DRG Use tables W7 and X6	N4, 8, 10, 11, 12
		25	K655LINK-C-LR-W0X-A-DRG Use tables W7 and X6	N4, 8, 10, 11, 12
		35	755LINK-C-LR-W0X-A-DRG Use tables W9 and X6	N4, 8, 10, 11, 12
	Insulating plug	25	K650LB	N3
		35	750LB	N3
	Cam-Op alignment bracket	15	650CAB	–
		25	K650CAB	–
		35	750CAB	–
	Compression lug	All	03700X Use table X6	N5
			03702X Use table X6	N6
			04601X	–
	Cam-Op size sensitive kit (cable adapter and lug)	15/25	655CK-W0X Use tables W7 and X6	N10
		35	755CK-W0X Use tables W9 and X6	N10
	Cam-Op retaining sleeve	All	650RSC	N8
	Cam-Op cable joint kit	15	655BI-LINK-C-LR-W0X-DRG Use tables W7 and X6	N7, 8, 10, 11, 12
		25	K655BI-LINK-C-LR-W0X-DRG Use tables W7 and X6	N7, 8, 10, 11, 12
		35	755BI-LINK-C-LR-W0X-DRG Use tables W9 and X6	N7, 8, 10, 11, 12
	Cam-Op loadbreak reducing tap plugs (visi-break)	15	650LK-C-VB	–
		25	K650LK-C-VB	–
		35	750LK-C-VB	–
	Cam-Op link	15	650LK-C	–
		25	K650LK-C	–
		35	750LK-C	–
	Grounding elbow (1/0 AWG x 6' ground lead)	15	160GLR	–
		25	370GLR	N 13
		35	370GLR	N 13
	Test rod	All	370TR	–

**N1.** Cam-Op connector kit includes: (1) Cam-Op link; (1) elbow housing; (1) cable adapter; (1) 0370 style lug; (1) bushing extender; (2) retainer sleeves; (1) insulated cap; (1) mountable insulated bushing and (1) alignment bracket.

**N2.** Mountable insulated bushing included with Cam-Op connector kit. Requires three threaded studs on equipment faceplate for installation.

**N3.** Use with the retrofit Cam-Op connector kit.

**N4.** Retrofit Cam-Op connector kit includes: (1) link; (1) elbow housing; (1) cable adapter; (1) 0370 style lug; (1) bushing extender; (2) retainer sleeves; (1) insulated cap; (1) insulating plug; and (1) alignment bracket.

**N5.** Aluminum lug for use on aluminum or copper conductors. DO NOT substitute threaded 03600X lug.

**N6.** Copper lug for use on COPPER CONDUCTOR ONLY.

DO NOT substitute 03602X threaded lug.

**N7.** Cam-Op cable joint kit includes: (1) Cam-Op link; (1) Cam-Op BI-SOP; (2) elbow housings; (2) cable adapters; (2) 0370 style lugs; (2) retainer sleeves; (1) insulated cap.

**N8.** 600ATM is recommended for installing Cam-Op retaining sleeves.

**N9.** For 900-amp ratings, substitute 675 for 650 and 655; 676 for 656; K675 for K650 and K655; K676 for K656; 775 for 750 and 755; 776 for 756 and 2X for 0X in the catalog number. The 900-amp rating requires copper current-carrying connector components and copper conductor cable.

**N10.** Add suffix symbol from page 75 to include cable shield grounding kit and/or cable jacket sealing kit.

**N11.** To add elbows or arresters instead of insulating caps, replace the “DRG” with “LR-WX” for elbows (with test point) or “ESA” for elbow arresters.

**N12.** 600 series elbows with IEEE 386 capacitive test points are available by substituting 656 for 655; K656 for K655; K676 for K675; 756 for 755; 676 for 675; K676 for K675 and 776 for 775 in the catalog number.

**N13.** Rated for both 25 kV and 35 kV applications.

Refer to the W and X tables on pages 84–85 for sizing to cable insulation diameter and conductor size. For cable shield adapters and jacket seals, see pages 74–75.

## 600 series test and ground and Stick-Op™ deadbreak connector systems

The Elastimold® 600 series test and ground and Stick-Op deadbreak connector systems incorporate provisions for hotstick operation of de-energized primary feeder or network circuits.

The test and ground and Stick-Op connectors allow direct testing and grounding with no required cable movement.

Test and ground is ideal for equipment applications that include viewing windows to provide an internal visible break and that do not require hotstick removal of the elbows.

Stick-Op provides an external visible break by hotstick removal of the elbow.

Test and ground and Stick-Op connectors are bolted and installed using torque-controlled tools.

### Ratings overview

See pages 4–5 for complete information.

#### Current ratings

- 600 A and 900 A continuous
- 25 kA sym., 10 cycles

Note: 900 A ratings require copper cable and copper current-carrying components.

#### Continuous voltage ratings

##### 15 kV class

- 8.3 kV phase-to-ground
- 14.4 kV phase-to-phase
- 95 kV BIL
- 34 kV AC withstand
- 53 kV DC withstand
- 11 kV corona extinction

##### 25 kV class

- 15.2 kV phase-to-ground
- 26.3 kV phase-to-phase
- 125 kV BIL
- 40 kV AC withstand
- 78 kV DC withstand
- 19 kV corona extinction

##### 35 kV class

- 21.1 kV phase-to-ground
- 36.6 kV phase-to-phase
- 150 kV BIL
- 50 kV AC withstand
- 103 kV DC withstand
- 26 kV corona extinction





# 600 A deadbreak elbow separable connectors



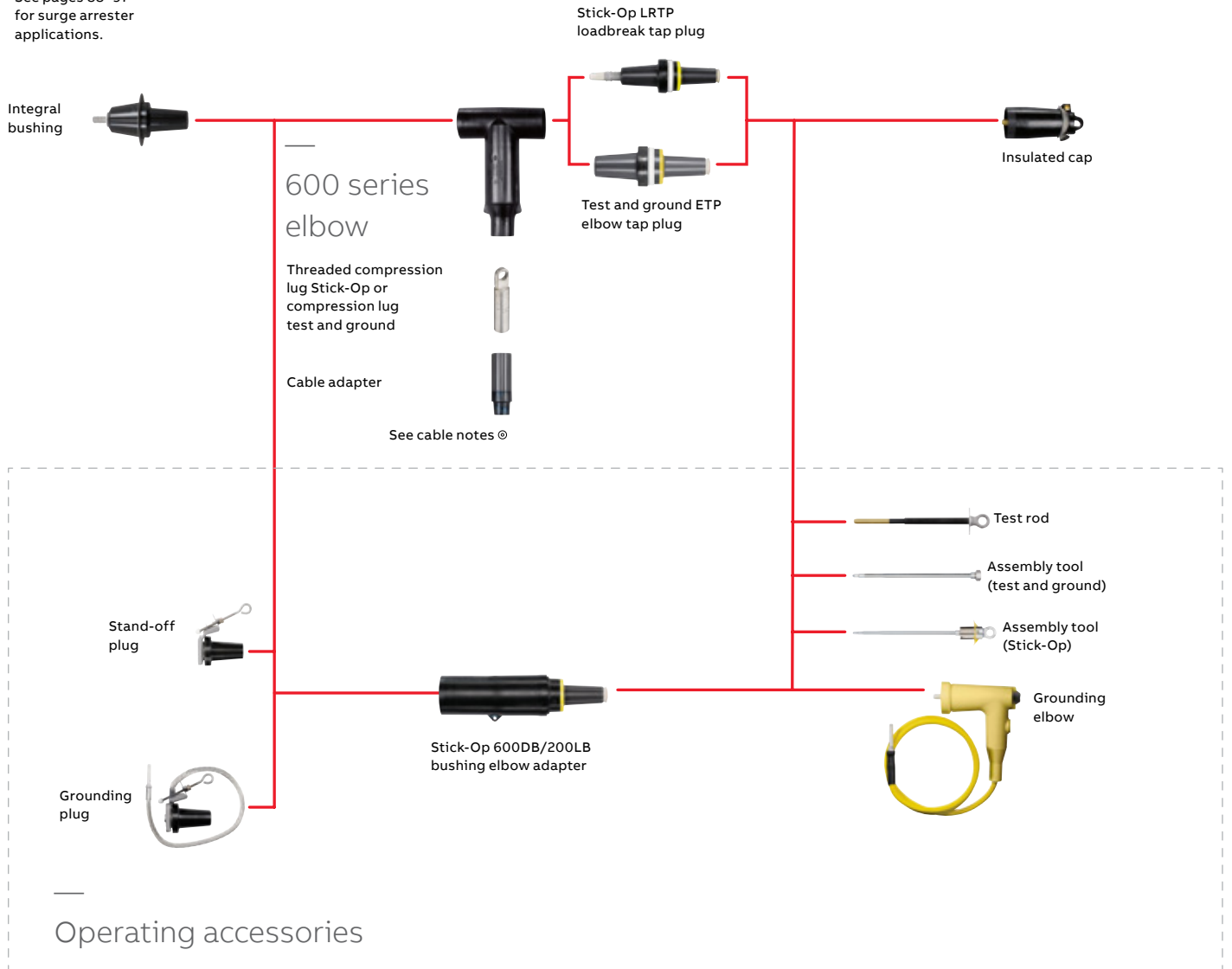

600 series test and ground and Stick-Op™ deadbreak connector systems

## Stick-Op and test and ground system – 600 series deadbreak

See pages 88–97 for surge arrester applications.















## Stick-Op kits

Image (not to scale)	Description	Voltage class (kV)	Cat. no.	Notes
	Test and ground connector kit	15	655ETP-WOX-DRG Use tables W7 and X6	N1, 4, 5, 6, 11, 13
		25	K655ETP-WOX-DRG Use tables W7 and X6	
		35	755ETP-WOX-DRG Use tables W9 and X6	
	Test and ground replacement connector kit	15	655RETP	N4, 5, 6, 11, 13, 14
		25	K655RETP	
	Stick-Op connector kit	15	655LRTP-WOX-DRG Use tables W7 and X6	N2, 3, 4, 5, 8, 11
		25	K655LRTP-WOX-DRG Use tables W7 and X6	
		35	755LRTP-WOX-DRG Use tables W9 and X6	
	Stick-Op replacement connector kit	15	655RLRTP	N3, 4, 5, 8, 11, 14
		25	K655RLRTP	

## 600 A deadbreak elbow separable connectors

600 series test and ground and Stick-Op™ deadbreak connector systems

### Stick-Op accessories

Image (not to scale)	Description	Voltage class (kV)	Cat. no.	Notes
	Stick-Op size-sensitive kit (cable adapter and threaded lug)	15/25	655TCK-WOX Use tables W7 and X6	N5
		35	755TCK-WOX Use tables W9 and X6	N5
	Extraction tool	All	650ET	N10
	Grounding elbow (1/0 AWG x 6' ground lead)	15	160GLR	–
		25	370GLR	N12
		35	370GLR	N12
	Test rod	All	370TR	–
	Assembly tool (Stick-Op)	All	600AT	N3
	Assembly tool (test and ground)	All	600ATM	N13
	Test and ground loadbreak elbow tap plug	15	650ETP	N4, 13, 16
		25	K650ETP	N4, 13, 16
		35	750ETP	N4, 13, 16
	Stick-Op loadbreak reducing tap plug	15	650LRTPA3	N3, 4
		25	K650LRTPA2	–
		35	750LRTPA2	–
	Stick-Op bushing adapter	15	655BEA3	N3, 4
		25	K655BEA2	–
		35	755BEA2	–
	Compression lug test and ground	All	03700X Use tables X6	N6
		All	03702X Use tables X6	N7
	Threaded compression lug Stick-Op	All	03600X Use tables X6	N8, 15
		All	03602X Use tables X6	N9
	Test and ground size-sensitive kit (cable adapter and lug)	15/25	655CK-WOX Use tables W7 and X6	N4, 5
		35	755CK-WOX Use tables W9 and X6	N4, 5

**N1.** Test and ground kit includes: insulated cap; test and ground reducing tap plug; 600 series elbow housing; cable adapter; and 0370 style compression lug.

**N2.** Stick-Op kit includes insulated cap; Stick-Op loadbreak reducing tap plug; 600 series elbow housing; cable adapter; and threaded 0360 style compression lug.

**N3.** 600AT assembly tool required for operation and/or installation of Stick-Op.

**N4.** For 900 A ratings, substitute 675 for 650 and 655; 676 for 656; K675 for K650 and K655; K676 for K656; 775 for 750 and 755; 776 for 756 and 2X for 0X in the catalog number. The 900 A rating requires copper current-carrying connector components and copper conductor cable.

**N5.** Add suffix symbol from page 75 to include cable shield grounding kit and/or cable jacket sealing kit.

**N6.** Aluminum lug for use on aluminum or copper conductors.

DO NOT substitute threaded 03600X lug.

**N7.** Copper lug for use on COPPER CONDUCTOR ONLY.

DO NOT substitute 03602X threaded lug.

**N8.** Threaded aluminum lug (Stick-Op only) for use on copper or aluminum conductors. DO NOT substitute unthreaded 03700X lugs. DO NOT use with 675, 676, K675, K676, 775 or 776 catalog numbers.

**N9.** Threaded copper lug (Stick-Op only) for use on copper conductors only. DO NOT substitute unthreaded 03702X lugs.

**N10.** Required to disassemble Stick-Op loadbreak reducing tap plug from the threaded compression lug and 600 series elbow after the shear-pin is broken during assembly.

**N11.** 600 series Elbows with IEEE 386 capacitive test points are available by substituting 656 for 655; K656 for K655; K676 for K675; 756 for 755; 676 for 675; K676 for K675 and 776 for 775 in the catalog number.

**N12.** Rated for both 25 kV and 35 kV applications.

**N13.** 600ATM assembly tool required for test and ground assembly. 50–60 ft./lbs. torque wrench required but not included.

**N14.** Replacement elbow includes: insulated cap; reducing tap plug; 600 series elbow housing; I-adapter; straight receptacle, resulting in a net gain of 20" in length vs. a standard elbow kit. Compression lugs and cable adapters are ordered separately.

**N15.** Retrofit sleeve to convert 03600X series lug to a 03700X series lug (catalog number 650-353).

**N16.** Add "SP" to the part number to include factory-assembled stud.

Refer to the W and X tables on pages 84–85 for sizing to cable insulation diameter and conductor size. For cable shield adapters and jacket seals, see pages 74–75.

## Advanced shear bolt connection system

### Bolt heads shear off at the correct torque

The Elastimold advanced shear bolt connection system is the latest solution to be incorporated into the Elastimold portfolio of separable connectors. It's consistent with the system's overall purpose in providing more safe, reliable and flexible separable connectors for underground cable.

#### Overview

Reliable solution that reduces the likelihood of human error. Bolt heads shear off at the right torque with a standard wrench. Leaves a smooth, flush finish with no protruding edges.

- Simplifies and speeds installations – Only a standard wrench is needed; no dies or pneumatic tools
- Only five range-taking shear bolt connectors are needed to accommodate multiple wire sizes #2 AWG to 1500 kcmil
- Applicable for 600 A and 900 A current rating
- Compatible with aluminum and copper conductors

#### Applications

Shear bolt connectors are available in a range-taking selection of five sizes, which substantially reduces the chance of accidentally installing the wrong connector.

- IEEE 386 separable connectors
- 600/900 amp elbow connectors, vault stretchers and straight receptacles from 15 kV up to 35 kV
- Aluminum or copper conductors
- Cables from #2 AWG to 1500 kcmil\*

\*1500 kcmil only with 35 kV.

#### Installation

Installation with a standard wrench and no additional components, as well as easy shearing at the correct torque, make the Elastimold advanced connection system shear bolt a time-saving resource.

- The circuit must be de-energized before installation
- Brush conductor to break up the oxide layer
- Fully insert conductor into barrel
- Torque bolts steadily with tool until head shears off, beginning with bolt farthest from the connector head and working up
- Follow detailed instructions provided with the product

#### Benefits

##### Connectivity

- Increased clamping area results in a tighter, more secure connection

##### Reliability

- Meets IEEE386 latest revision
- No filing or extra components needed
- Electro-tin plated
- Lubricated with special grease
- The bolt heads always shear off at the required torque
- Special design with grooves for improved contact

##### Flexibility

- Compatible with Elastimold T-body, vault stretcher and straight receptacles
- Range-taking in each connector
- Installation using a standard wrench and socket
- Designed and tested for use on both aluminum and copper conductors
- Self-centering rings for lower diameter conductor for each connector

Leaves a smooth finish that fits flush against the body of the connector – no sharp edges.



## Advanced shear bolt connection system

—  
01 Elastimold  
advanced shear bolt  
connection system  
—

02 Shear bolt family  
—



—  
01  
—



—  
02  
—

Conductor size (AWG or kcmil)	A		B			C		D		Cat no.
	in.	mm	in.	mm	in.	mm	in.	mm		
#2-300	1.18	30	6.10	155	1.42	36	0.689	17.5	EACT-0300	
4/0-500	1.30	33	6.10	155	1.42	36	0.689	17.5	EACT-0500	
350-750	1.65	42	6.10	155	1.42	36	0.689	17.5	EACT-0750	
750-1250	2.05	52	6.10	155	1.42	36	0.689	17.5	EACT-1250	
1500	2.36	60	6.69	170	1.30	35	0.689	15.5	EACT-1500	

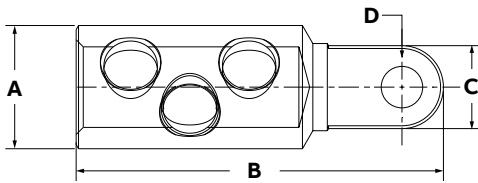

\*Shear bolt options now available with separable cable joints.

—  
04 Note: To hold the  
connector securely  
in place during the  
shearing process,  
it is recommended  
that a connector vise  
(CV100) be used.  
—



—  
04  
—

# Advanced shear bolt connection system

## 600 amp deadbreak elbow – Ordering information



01 T-body 600 A LR kit

### Catalog number selection

#### Step 1

- Select voltage class and ampacity
- Select the option for capacitive test point (with or without)
- Select the kit type

#### Step 2 (W)

- According to the voltage class, select the right code for W; for 15/25 kV system, use table W7, and for 35 kV, use table W9

#### Step 3 (X)

- Choose the proper shear bolt lug code according to the conductor size from the conductor code table
- Insert the code into catalog number

#### LR and DLR kit contains

- 1 elbow connector housing
- 1 shear bolt lug
- 1 stud
- 1 insulated plug with cap
- 3 tubes of lubricant
- 1 cable adapter

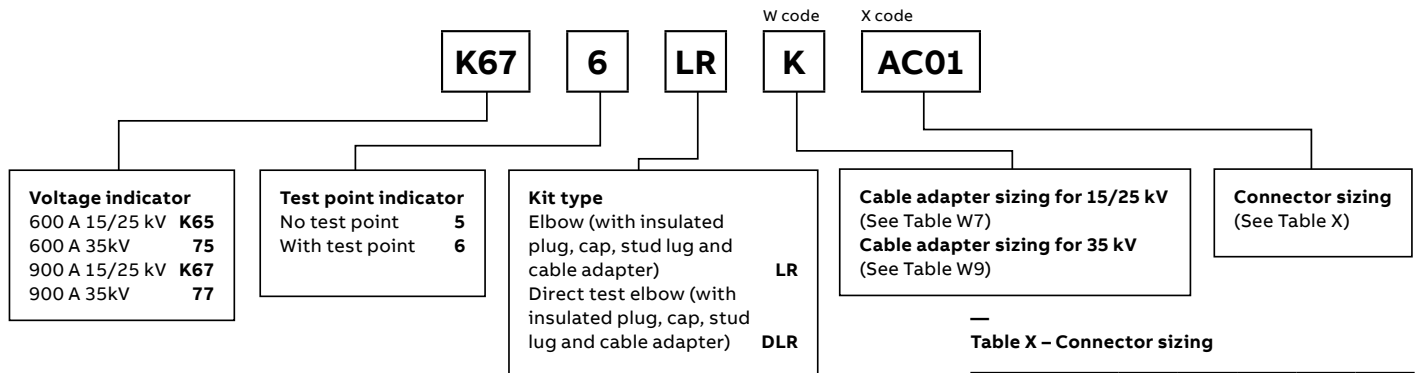

Table W7 – Cable adapter sizing for 15/25 kV

Cable insulation dia. range				
Cable insulation diameter in inches		Cable insulation diameter in millimeters		Symbol for W
Min.	Max.	Min.	Max.	
0.420	0.660	10.7	16.8	D
0.530	0.680	13.5	17.3	E
0.640	0.820	16.3	20.8	F
0.760	0.950	19.3	24.1	G
0.850	1.050	21.6	26.7	H
0.980	1.180	24.9	30.0	J
1.090	1.310	27.7	33.3	K
1.180	1.465	30.0	37.2	L
1.280	1.430	32.5	36.3	LM
1.370	1.630	34.8	41.4	M
1.550	1.780	39.4	45.2	N
1.725	1.935	43.8	49.1	P

Table W9 – Cable adapter sizing for 35 kV

Cable insulation dia. range				
Cable insulation diameter in inches		Cable insulation diameter in millimeters		Symbol for W
Min.	Max.	Min.	Max.	
0.76	0.950	19.3	24.1	G
0.85	1.050	21.6	26.7	H
0.98	1.180	24.9	30.0	J
1.09	1.310	27.7	33.3	K
1.18	1.465	30.0	37.2	L
1.37	1.630	34.8	41.4	M
1.515	1.780	38.5	45.2	N
1.725	1.935	43.8	49.1	P
1.9	2.120	48.3	53.8	Q
2.115	2.235	53.7	56.8	R

Table X – Connector sizing

AWG or kcmil	Code
#2	AC01
#1	
1/0	
2/0	
3/0	AC02
4/0	
250	
300	
350	
400	
450	
500	AC03
550	
600	
650	
700	
750	AC04
800	
900	
1000	
1250	
1500*	AC05

\*1500 kcmil — 35 kV only



## Advanced shear bolt connection system

### Separable cable joints – Ordering information

Now available with I, Y's and H's.

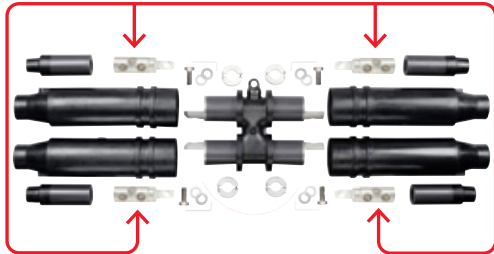

4 Ways compact H shown

#### Catalog number selection

##### Step 1

- Select voltage class
- Select the kit type
- Select spiking aid option

##### Step 2 (W)

- According to the voltage class, select the right code for W; for 15/25 kV system, use table W7, and for 35 kV, use table W9

##### Step 3 (X)

- Choose the proper shear bolt lug code according to the conductor size from the conductor code table
- Insert the code into catalog number

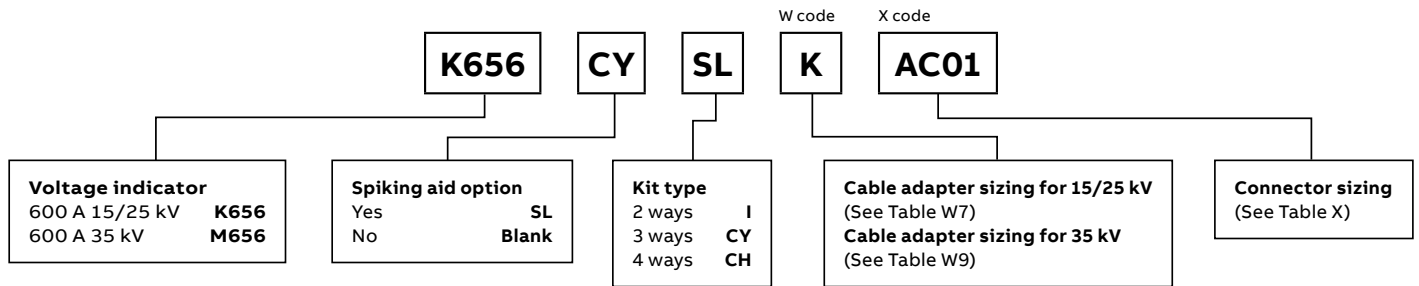

Table W7 – Cable adapter sizing for 15/25 kV

Cable insulation dia. range				
Cable insulation diameter in inches		Cable insulation diameter in millimeters		Symbol for W
Min.	Max.	Min.	Max.	
0.420	0.660	10.7	16.8	D
0.530	0.680	13.5	17.3	E
0.640	0.820	16.3	20.8	F
0.760	0.950	19.3	24.1	G
0.850	1.050	21.6	26.7	H
0.980	1.180	24.9	30.0	J
1.090	1.310	27.7	33.3	K
1.180	1.465	30.0	37.2	L
1.280	1.430	32.5	36.3	LM
1.370	1.630	34.8	41.4	M
1.550	1.780	39.4	45.2	N
1.725	1.935	43.8	49.1	P

Table W9 – Cable adapter sizing for 35 kV

Cable insulation dia. range				
Cable insulation diameter in inches		Cable insulation diameter in millimeters		Symbol for W
Min.	Max.	Min.	Max.	
0.760	0.950	19.3	24.1	G
0.850	1.050	21.6	26.7	H
0.980	1.180	24.9	30.0	J
1.090	1.310	27.7	33.3	K
1.180	1.465	30.0	37.2	L
1.370	1.630	34.8	41.4	M
1.515	1.780	38.5	45.2	N
1.725	1.935	43.8	49.1	P
1.900	2.120	48.3	53.8	Q
2.115	2.235	53.7	56.8	R

#### Each bus bar kit contains

	2 Ways	3 Ways	4 Ways
Bus housing	I	CY	CH
Straight receptacle	2	3	4
Aluminum shear bolt	2	3	4
Adapter retaining ring	2	3	4
Cable adapter	2	3	4

Table X – Connector sizing

AWG or kcmil	Stranded/ compressed/ compact	Code
#2		AC01
#1		
1/0		
2/0		
3/0		AC02
4/0		
250		
300		
350		
400		
450		
500		AC03
550		
600		
650		
700		
750		AC04
800		
900		
1000		
1250		

# Advanced shear bolt connection system

## Vault stretcher – Ordering information



01 Stacked vault stretcher 3-ways kit

### Catalog number selection

#### Step 1

- Select voltage class and ampacity
- Select the kit type

#### Step 2 (W)

- According to the voltage class, select the right code for W; for 15/25/35 kV system, use table W7

#### Step 3 (X)

- Choose the proper shear bolt lug code according to the conductor size from the conductor code table
- Insert the code into catalog number

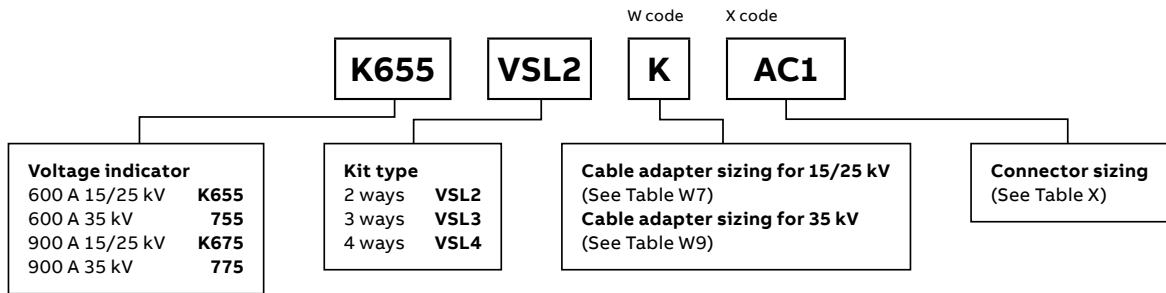

Table W7 – Cable adapter sizing for 15/25/35 kV

Cable insulation dia. range		Cable insulation diameter in millimeters		Symbol for W
Min.	Max.	Min.	Max.	
0.420	0.660	10.7	16.8	D
0.530	0.680	13.5	17.3	E
0.640	0.820	16.3	20.8	F
0.760	0.950	19.3	24.1	G
0.850	1.050	21.6	26.7	H
0.980	1.180	24.9	30.0	J
1.090	1.310	27.7	33.3	K
1.180	1.465	30.0	37.2	L
1.280	1.430	32.5	36.3	LM
1.370	1.630	34.8	41.4	M
1.550	1.780	39.4	45.2	N
1.725	1.935	43.8	49.1	P

### Each bus bar kit contains

	2 Ways	3 Ways	4 Ways
Vault stretcher housing	1	1	2
T-body housing	-	1	-
Aluminum shear bolt	2	3	4
Connecting plug	-	1	1
Cable adapter	2	3	4
Insulated plug	2	2	2

Table X – Connector sizing

AWG or kcmil	Code
#2	AC01
#1	
1/0	
2/0	
3/0	
4/0	AC02
250	
300	
350	
400	
450	
500	AC03
550	
600	
650	
700	
750	AC04
800	
900	
1000	
1250	
1500*	AC05

\*1500 kcmil — 35 kV only

# Advanced shear bolt connection system

## ComboT – Ordering information



01 Elastimold® advanced connection system

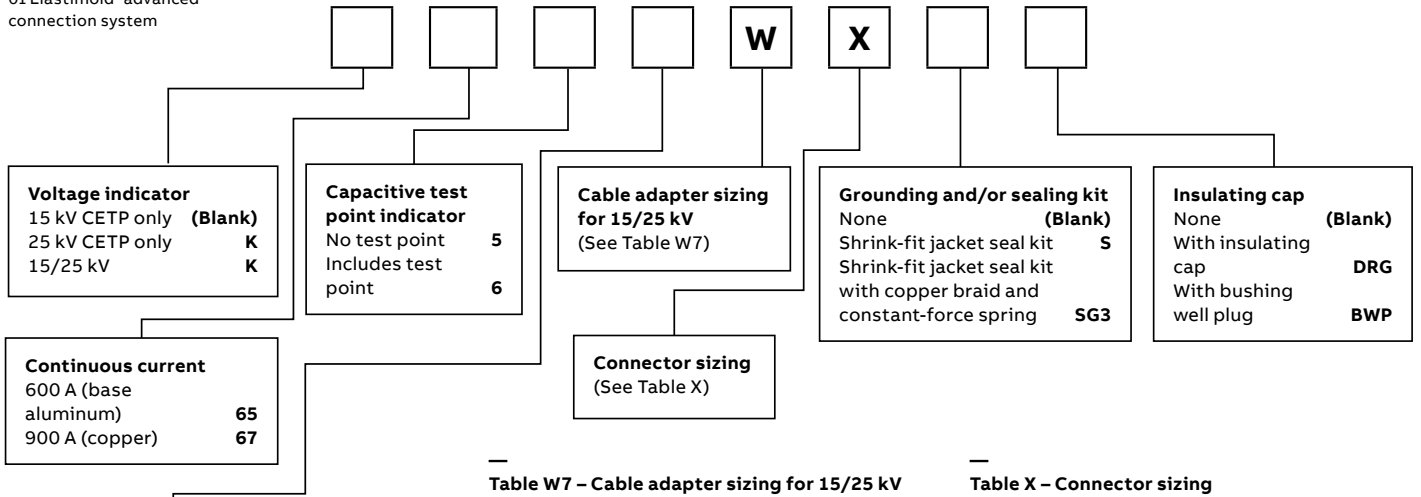

**Voltage indicator**  
 15 kV CETP only (Blank)  
 25 kV CETP only K  
 15/25 kV K

**Continuous current**  
 600 A (base aluminum) 65  
 900 A (copper) 67

**Capacitive test point indicator**  
 No test point 5  
 Includes test point 6

**Cable adapter sizing for 15/25 kV**  
 (See Table W7)

**Grounding and/or sealing kit**  
 None (Blank)  
 Shrink-fit jacket seal kit S  
 Shrink-fit jacket seal kit with copper braid and constant-force spring SG3

**Insulating cap**  
 None (Blank)  
 With insulating cap DRG  
 With bushing well plug BWP

**Connector sizing**  
 (See Table X)

**Kit type**

- Basic ComboT elbow reducing tap plug with stud **BCETP**
- ComboT elbow reducing tap plug with stud, cable adapter, lug and insulated cap kit **CETP**
- Basic ComboT connecting plug with stud **BCCP**
- ComboT connecting plug with stud, cable adapter and lug kit **CCP**
- Basic ComboT bushing well with stud **BCBW**
- ComboT bushing well with stud, cable adapter and lug kit **CBW**

Table W7 – Cable adapter sizing for 15/25 kV

Cable insulation dia. range		Cable insulation diameter in millimeters		Symbol for W
Min.	Max.	Min.	Max.	
0.420	0.660	10.7	16.8	D
0.530	0.680	13.5	17.3	E
0.640	0.820	16.3	20.8	F
0.760	0.950	19.3	24.1	G
0.850	1.050	21.6	26.7	H
0.980	1.180	24.9	30.0	J
1.090	1.310	27.7	33.3	K
1.180	1.465	30.0	37.2	L
1.280	1.430	32.5	36.3	LM
1.370	1.630	34.8	41.4	M
1.550	1.780	39.4	45.2	N
1.725	1.935	43.8	49.1	P

Table X – Connector sizing

AWG or kcmil	Stranded/ compressed/ compact	Code
#2	AC01	
#1		
1/0		
2/0		
3/0		
4/0	AC02	
250		
300		
350		
400		
450		
500	AC03	
550		
600		
650		
700		
750		
800		AC04
900		
1000		
1250		

## Veri-Spike™

Grounding-aid device

The Elastimold Veri-Spike grounding-aid solution enables quick and safe verification of de-energization. Water-tight and shielded, Veri-Spike meets the IEEE 386 standard for 15/25 kV and 35 kV applications.

### Overview

The Elastimold Veri-Spike grounding-aid device is designed to provide a safe and quick method to verify that a system is de-energized before any maintenance begins. The Veri-Spike device consists of a sacrificial cap and a connecting plug that installs easily in place of a basic insulating plug. Once installed, the replaceable sacrificial cap can either be cut or spiked to verify that the system is de-energized and replaced with a grounding ball to properly ground the system. The Veri-Spike grounding-aid device, made of ethylene propylene diene monomer (EPDM) rubber, is available in both 15/25 kV and 35 kV ratings and meets the IEEE 386 standard.

### Technical information

15/25 kV class (5 kV–28 kV)

Voltage ratings

- 15/25 kV class (5 kV through 28 kV)
- 16.2 kV phase-to-ground
- 125 kV BIL
- 45 kV AC withstand
- 21.5 kV corona extinction

Current ratings

- 600 A continuous
- 25 kA sym., 10 cycles

35 kV class

Voltage ratings

- 21.1 kV phase-to-ground
- 150 kV BIL
- 50 kV AC withstand
- 26 kV corona extinction

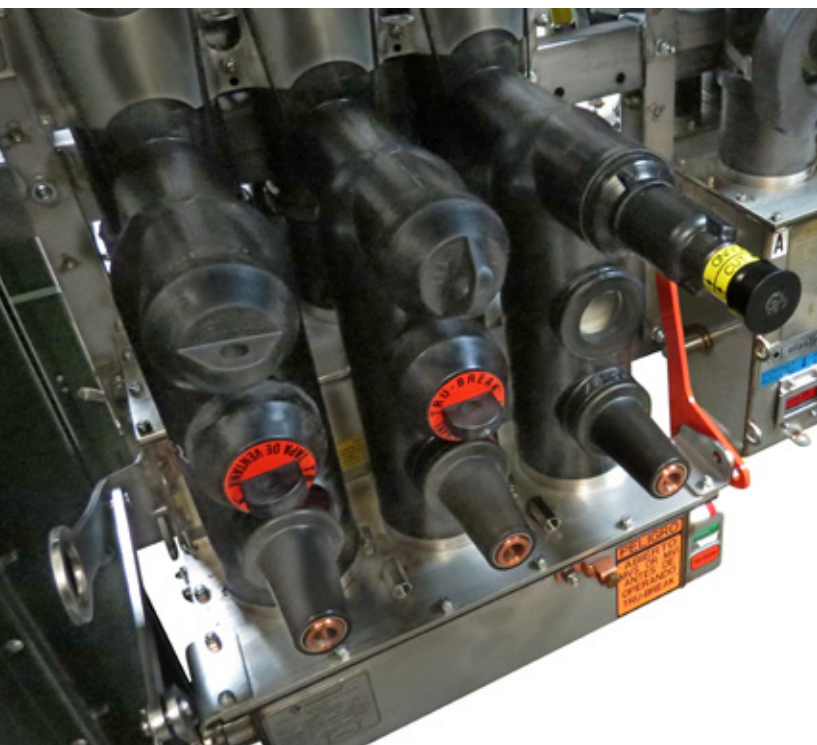

# Veri-Spike™

Grounding-aid device

Delivering value

**Safe**

- Helps ensure system is 100% de-energized before work
- Reduces outage times

**Versatile**

- Multiple 600 A cable accessories are available

**Reliable**

- 100% factory tested to IEEE 386 standard
- Completely shielded and watertight EPDM material

**Flexible**

- Made for 15/25 kV and 35 kV classes
- Cut or spike to verify system de-energization

Veri-Spike grounding-aid device

Conductor size	Length		Width		Cat no.
	in	mm	in	mm	
15/25 kV	9.707	246.558	3.000	76.20	VSGADCP-25
35 kV	10.707	271.958	3.000	76.20	VSGADCP-35

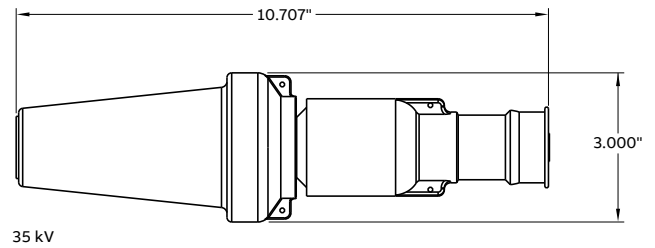
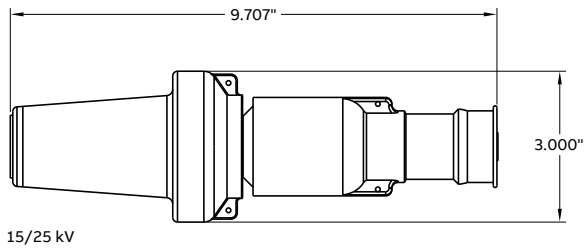

01 15/25kV Veri-Spike  
- VSGADCP-25

02 35kV Veri-Spike  
- VSGADCP-35

03 Sacrificial cap - K650SL

04 Grounding bar for  
spiking aid - K650SLGB



01

02

03

04

# Veri-Spike™

## K656LR-WX- with Veri-Spike



01 Compression lug

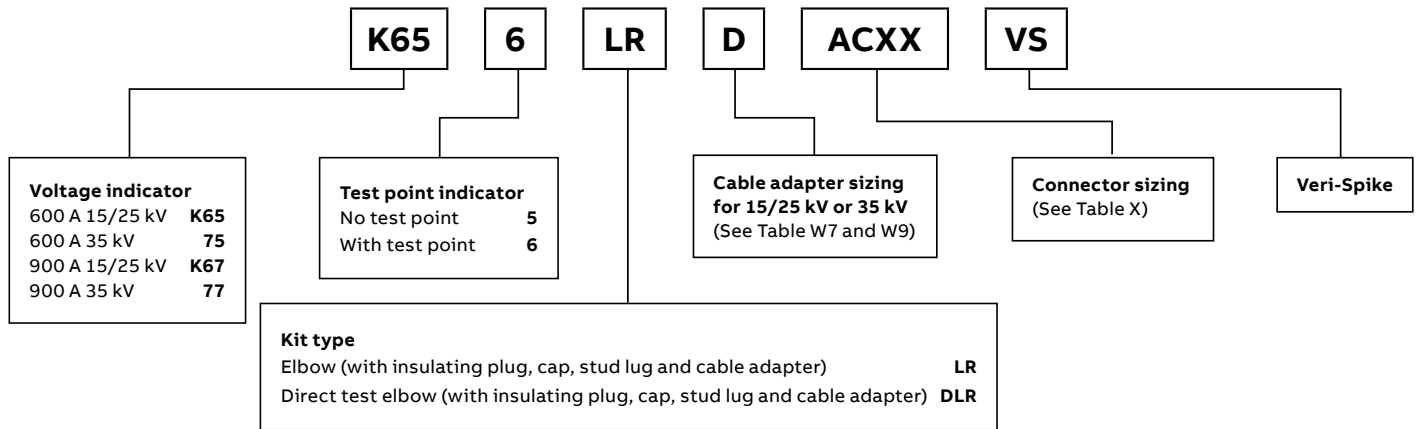

**W7 – Cable adapter sizing for 15/25 kV**

Cable insulation dia. range				
Cable insulation diameter in inches		Cable insulation diameter in millimeters		Symbol for W
Min.	Max.	Min.	Max.	
0.42	0.66	10.7	16.8	<b>D</b>
0.53	0.68	13.5	17.3	<b>E</b>
0.64	0.82	16.3	20.8	<b>F</b>
0.76	0.95	19.3	24.1	<b>G</b>
0.85	1.05	21.6	26.7	<b>H</b>
0.98	1.18	24.9	30	<b>J</b>
1.09	1.31	27.7	33.3	<b>K</b>
1.18	1.465	30	37.2	<b>L</b>
1.28	1.43	32.5	36.3	<b>LM</b>
1.37	1.63	34.8	41.4	<b>M</b>
1.55	1.78	39.4	45.2	<b>N</b>
1.725	1.935	43.8	49.1	<b>P</b>

\*1500 kcmil — 35 kV only

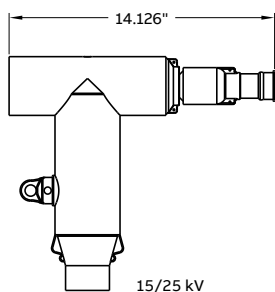

**W9 – Cable adapter sizing for 35 kV**

Cable insulation dia. range				
Cable insulation diameter in inches		Cable insulation diameter in millimeters		Symbol for W
Min	Max	Min	Max	
0.76	0.95	19.3	24.1	<b>G</b>
0.85	1.05	21.6	26.7	<b>H</b>
0.98	1.18	24.9	30	<b>J</b>
1.09	1.31	27.7	33.3	<b>K</b>
1.18	1.465	30	37.2	<b>L</b>
1.37	1.63	34.8	41.4	<b>M</b>
1.515	1.78	38.5	45.2	<b>N</b>
1.725	1.935	43.8	49.1	<b>P</b>
1.9	2.12	48.3	53.8	<b>Q</b>
2.115	2.235	53.7	56.8	<b>R</b>

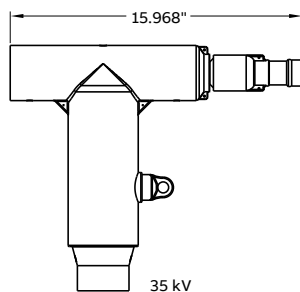

**Table X – Connector sizing**

AWG or kcmil		Code
Stranded/ compressed/ compact		
#2	AC01	
#1		
1/0		
2/0		
3/0		
4/0	AC02	
250		
300		
350		
400		
450		
500	AC03	
550		
600		
650		
700		
750		
800	AC04	
900		
1000		
1500*		AC05

Connector also available in a compression lug

# Veri-Spike™

Vault stretcher with Veri-Spike

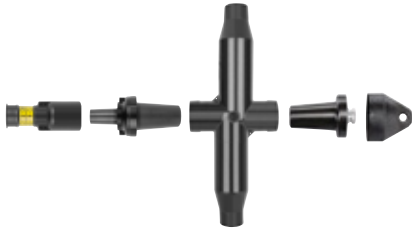

01 Stacked vault stretcher 3-ways kit

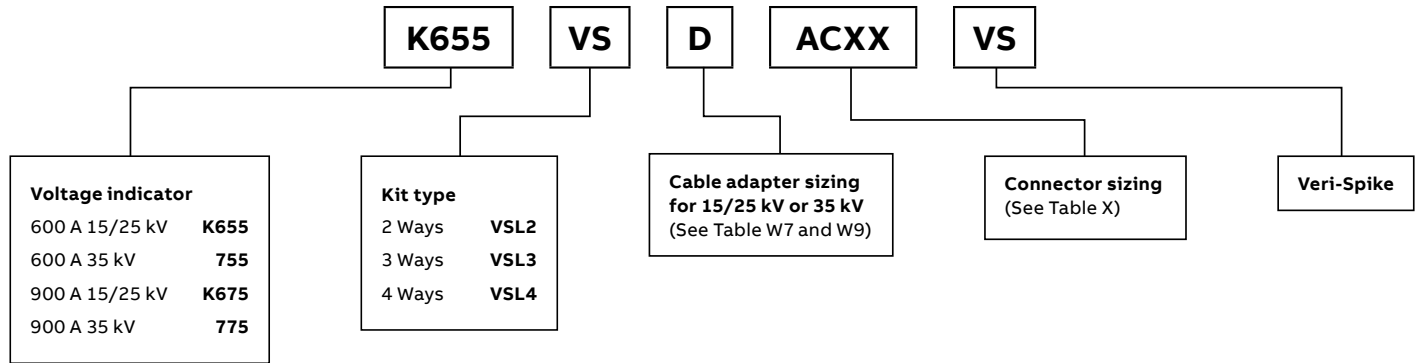

W7 – Cable adapter sizing for 15/25/35 kV

Cable insulation dia. range		Cable insulation diameter in millimeters		Symbol for W
Min.	Max.	Min.	Max.	
0.42	0.66	10.7	16.8	D
0.53	0.68	13.5	17.3	E
0.64	0.82	16.3	20.8	F
0.76	0.95	19.3	24.1	G
0.85	1.05	21.6	26.7	H
0.98	1.18	24.9	4.6	J
1.09	1.31	27.7	33.3	K
1.18	1.465	30	37.2	L
1.28	1.43	32.5	36.3	LM
1.37	1.63	34.8	41.4	M
1.55	1.78	39.4	45.2	N
1.725	1.935	43.8	49.1	P

\*1500 kcmil — 35 kV only

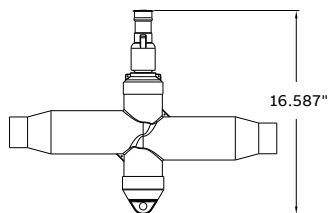

15/25 kV

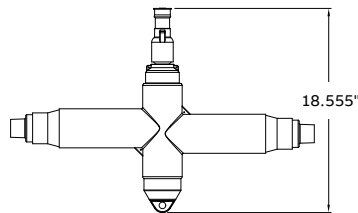

35 kV

Table X – Connector sizing

AWG or kcmil	Code
#2	AC01
#1	
1/0	
2/0	
3/0	
4/0	AC02
250	
300	
350	
400	
450	
500	AC03
550	
600	
650	
700	
750	
800	
900	
1000	AC04
1500*	AC05

Connector also available in a compression lug

## Grounding-aid device (GAD)

### Don't chance grounding safety

When available fault currents exceed 10 kA in underground systems, the Elastimold® grounding-aid device (GAD) is a solution.

The GAD provides a permanent, reliable, direct 600 A or 900 A, 25 kA-rated ground connection without the need to reconfigure or install additional equipment such as reducing plugs or other temporary grounding adapters. The GAD comes complete with a removable protective cap with capacitive test point that allows easy access to check if the system is de-energized and designed to be hotstick workable.

#### Application

The Elastimold GAD is rated 25 kA and easily installs in the rear interface of a 600 A series elbow connector (T-body), providing a direct and permanent grounding connection, saving time, money and resources. It also supports faster system restoration by eliminating the need for configuring additional adapters and work steps.

The associated insulating cap with integral capacitive test point is conveniently located to help check that the circuit is de-energized and is completely hotstick workable.

Once the circuit is de-energized, it is grounded through a grounding cable to the grounding system. The GAD is available with both straight or ball receptacles for maximum ground clamp flexibility.

#### Features

- Available for 15/25 kV and 35 kV
- Short circuit withstand up to 25 kA, full copper construction ideal for 600 A and 900 A applications
- Provides a safe, highly reliable and visible direct connection to ground
- Includes insulated cap with capacitive test point
- Eliminates the need to install temporary grounding adapters
- Provides a direct test point and grounding connection for maximum personnel safety
- Elastimold-exclusive product design available in 15, 25 and 35 kV system classes
- Available for C and ball-stud grounding clamp types\*

\*Series GAD and GADDR are designed for standard C-clamp ground connections, and series BGAD and BGADDR are specifically designed for ball-stud ground connections.



## Grounding-aid device (GAD)



### Grounding connections

Illustration (not to scale)	Description	Voltage class (kV)	Cat. no.	Notes
	600 series grounding device kit	15/25	K676GADDRK	-
	600 series grounding device with ball kit	15/25	K676BGADDRK	N2
	600 series grounding device with 20 mm ball kit	15/25	K676B20GADDRK	N2
	600 series grounding device kit	35	776GADDRK	N1
	600 series grounding device with ball kit	35	776BGADDRK	N1, 2
	600 series grounding device with 20 mm ball kit	35	776B20GADDRK	N1, 2
	BGAD 1" hex deep socket	-	600-570	-

**N1.** Available with 200 kV BIL by adding suffix "-200".

**N2.** Part number 600-570 required to install (1" hex deep socket).

Refer to the W and X tables on pages 84-85 for sizing to cable insulation diameter and conductor size. For cable shield adapters and jacket seals, see pages 74-75.

## 600 A spiking aid cable accessories

—  
01 K655ELR  
—  
02 K656CHSL-HP

600 series separable cable joints with spiking aid option are available in spiking aid T and 2-, 3- and 4-way versions and include a capacitive test point as standard.

Units are interchangeable, featuring bolted connections. Designs are compact and ideally suited for small vaults and manholes.

### Spiking aid T

The spiking aid feature is available in the extended 600 A T-body using an extension connector to span the additional  $8\frac{5}{16}$ " (211 mm) distance and spiking location.

### Spiking aid separable cable joint

One leg of the stacked T-body cable joint is spiked/cut with a grounded guillotine-type cable cutter, near the T-body intersection. Once spiked and proven de-energized, the cable is re-prepped and a spiking-T with a lug extender is assembled and

reconnected to the stack. If this stack ever needs to be spiked again, the spiking-T provides a convenient place to spike with no additional cable prep required. Just replace the spiking-T and the lug extender for reduced outage and reduced cost.

The spiking aid adds a special interface with a replaceable appendage or link that provides a convenient place to spike the bus to assure that it is de-energized. This also ensures that all cables connected are de-energized. In the 2-, 3- and 4-way bus, an optional grounding attachment can be threaded onto the special interface for grounding during the outage. This ground also ensures that all connected cables are grounded. When the work is done and the ground removed, a new cap is installed.

#### Features

- Eliminates the need to spike the cable, thereby eliminating the need to splice or replace the cable
- Fully shielded, fully submersible, 100% peroxide-cured EPDM molded rubber
- Reusable components reduce inventory and other costs
- Includes integral capacitive test point
- Reduces outage time and outage cost









—  
01







—  
02

## 600 A spiking aid cable accessories

### Spiking aid separable cable joint

Image (not to scale)	Description	Voltage class (kV)	Cat. no.	Notes
	2-way insulated bus bar with test point and spiking aid	15/25	K656ISL	N1
	3-way insulated bus bar with test point and spiking aid	15/25	K656CYSL	N1
	4-way insulated bus bar with test point and spiking aid	15/25	K656CHSL	N1
	600 series spiking aid appendage	15/25, 35	K650SL	N2
	Grounding bar for spiking aid	15/25, 35	K650SLGB	–
	Assembly/disassembly tool	All	600YADT-2	N3
	Assembly/disassembly tool	All	600RRT-2	N3

### Repair and spiking aid T-body

Image (not to scale)	Description	Voltage class (kV)	Cat. no.	Notes
	600 series spiking elbow (with spiking contact, insulated plug, cap, stud, lug and cable adapter)	15/25	K656SELR-WOX	N4
	600 series extended elbow (with extended contact, insulated plug, cap, stud, lug and cable adapter)	15/25	K656ELR-WOX	N4
	600 series replacement elbow housing only without test point	15/25	K655BRLR	N5
	600 series replacement elbow housing only with test point	15/25	K656BRLR	N5
	600 series spiking elbow (with spiking contact)	15/25	K656BSELR	–
	600 series extended elbow (with extended contact)	15/25	K656BELR	–
	600 series spiking elbow (with spiking contact, insulating plug, cap, stud, lug and cable adapter)	15/25	K656SELR-WOX	N4
	600 series extended elbow (with extended contact, insulating plug, cap, stud, lug and cable adapter)	15/25	K656ELR-WOX	N4

**N1.** Insulated bus bar only.

**N2.** Replaceable spiking aid appendage for K656CHSL, K656CYSL and K656IS L and M series.

**N3.** Recommended for ease of assembly/disassembly of receptacles to bus. 600YADT-1 is lever drive and 600RRT is screw drive.

**N4.** Add suffix symbol from page 75 to include cable shield grounding kit and/or cable jacket sealing kit.

**N5.** Replacement elbow includes an I-adapter and straight receptacle, resulting in a net gain of 20".

Refer to the W and X tables on pages 84–85 for sizing to cable insulation diameter and conductor size. For cable shield adapters and jacket seals, see pages 74–75.

## 600 A separable cable joints

### 600 series separable cable joints

600 series separable cable joints are available in 2-, 3- and 4-way versions and include a capacitive test point as standard. Units are interchangeable, featuring bolted connections. Designs are compact and ideally suited for small vaults and manholes.

De-energized joints can be quickly and easily connected and disconnected using standard hand tools and equipment in accordance with accepted operating practices. Bus bars can be changed to add or remove cables from the joint.

Optional accessories include insulating and grounding caps and plugs that allow visible external separation, bypass, isolation, dead-ending, grounding and testing.

### Ratings overview

See pages 4–5 for complete information.

#### Current ratings (Prefixes: 650, K650, K655, K656 and 03700)

- 600 A continuous
- 25 kA sym., 10 cycles

#### Voltage ratings 15/25 kV class (5 kV through 28 kV)

- 16.2 kV phase-to-ground
- 28 kV phase-to-phase
- 140 kV BIL
- 45 kV AC withstand
- 84 kV DC withstand
- 21.5 kV corona extinction

#### 35 kV class

- 21.1 kV phase-to-ground
- 36.6 kV phase-to-phase
- 150 kV BIL
- 50 kV AC withstand
- 103 kV DC withstand
- 26 kV corona extinction

Note: Elastimold has increased the IEEE Standard Production and Design Test levels for 25 kV Class products to include 27 kV and 28 kV systems.

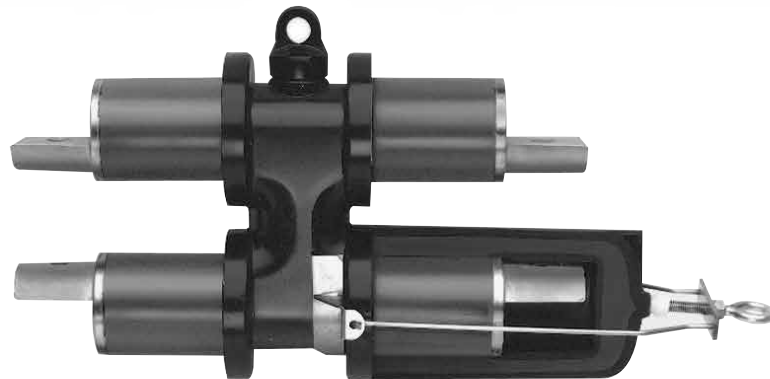

# 600 A separable cable joints

## 600 series separable cable joints

- 01 Separable joint (4-way)
- 02 Separable Wye-joint (3-way)
- 03 Separable straight joint (2-way)

### Separable cable joints – 600 series deadbreak

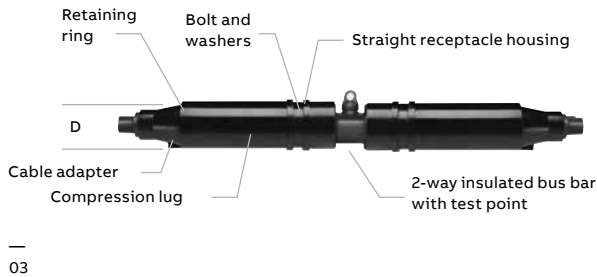
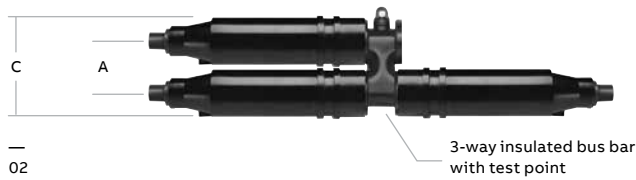
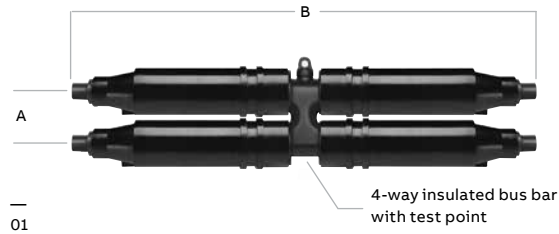

### Operating accessories



Insulated cap with bail



Insulating plug with test point and cap



Grounding cap













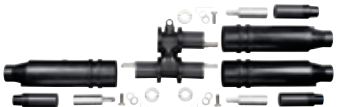



Grounding plug

Note: The separable cable joints shown here use a special "Y" interface that may not be interchangeable with other 600 series interfaces.













Dimension	In.
A	4¼
B	37½
C	8½
D	3¾

## 600 A separable cable joints

Image (not to scale)	Description	Voltage class (kV)	Cat. no.	Notes
	Separable straight joint pkg. (2-way) with test point	15/25	K656I-WOX	N1, 8, 12
		35	M656I-WOX Use tables W7 and X6	N1, 8, 12
	Basic housing pkg. straight joint with test point	15/25	K656I-HP	N2, 12
		35	M656I-HP	N2, 12
	Separable Wye joint pkg. (3-way) with test point	15/25	K656CY-WOX	N1, 8, 12
		35	M656CY-WOX Use tables W7 and X6	N1, 8, 12
	Basic housing pkg. Wye joint with test point	15/25	K656CY-HP	N2, 12
		35	M656CY-HP	N2, 12
	Separable "H" joint pkg. (4-way) with test point	15/25	K656CWOX	N1, 8, 12
		35	M656CWOX Use tables W7 and X6	N1, 8, 12
	Basic housing pkg. "H" joint with test point	15/25	K656CH-HP	N2, 12
		35	M656CH-HP	N2, 12
	2-way insulated bus bar with test point	15/25	K656I-BUS	N3, 12
		35	M656I-BUS	N3, 12
	3-way insulated bus bar with test point	15/25	K656CY-BUS	N3, 12
		35	M656CY-BUS	N3, 12
	4-way insulated bus bar with test point	15/25	K656CH-BUS	N3, 12
		35	M656CH-BUS	N3, 12
	Straight receptacle without test point	15/25	K655YSR-WOX	N4, 8
		35	M655YSR-WOX Use tables W7 and X6	N4, 8
	Direct test straight receptacle elbow	15/25	K655YDSR-WOX	N4, 8, 11
		35	M655YDSR-WOX Use tables W7 and X6	N4, 8, 11
	Direct test straight receptacle elbow with test point	15/25 kV	K656YDSR-WOX	N4, 8, 11
		35	M656YDSR-WOX Use tables W7 and X6	N4, 8, 11
	Straight receptacle housing only without test point	15/25	K655YBSR	N5, 10
		35	M655YBSR	N5, 10
	Straight receptacle housing only with test point	15/25	K656YBDSR	N5, 10
		35	M656YBDSR	N5, 10

## 600 A separable cable joints

### 600 A separable cable joints

Image (not to scale)	Description	Voltage class (kV)	Cat. no.	Notes
	Insulated cap with bail	15/25	K655YDR	-
		35	M655YDR	-
	Bail only	15/25	650BA	-
		35	-	-
	Cable adapter	15/25	655CA-W	-
		35	Use table W7	-
	Adapter retaining ring	15/25	650ARR-X	-
		35	Use table X6	-
	Compression lug	15/25	03700X	N7
		35	03702X	N9
	600 Series straight receptacle size-sensitive kit (cable adapter, retaining ring and lug)	15/25	655CK-W0X-ARR	N8
		35	Use tables W7 and X6	-
	Insulating plug with test point and cap	15/25	K650YBIP	-
		35	M650YBIP	-
	Grounding plug (4/0 AWG x 6' ground lead)	15/25	650YGP	-
		35	-	-
	Grounding cap (4/0 AWG x 6' ground lead)	15/25	650GYDR	-
		35	-	-
	Stainless steel bolt and washers	15/25	650BAW	-
		35	-	-
	Assembly/disassembly tool	All	600YADT-2	N6
	Assembly/disassembly tool	All	600RRT-2	N6

**N1.** Complete joint packages consisting of: insulated bus bar, straight receptacle housings, retaining rings, cable size adapters, lugs, bolts and washers.

**N2.** Housing packages consisting of the following non-size sensitive components of the joint: insulated bus bar, straight receptacle housings, bolts and washers.

**N3.** Insulated bus bar only.

**N4.** Straight receptacle consisting of: straight receptacle housing, retaining ring, cable adapter, lug, bolt and washers.

**N5.** Straight receptacle housing consisting of: straight receptacle housing, bolt and washers.

**N6.** Recommended for ease of assembly/disassembly of receptacles to bus. 600YADT-1 is lever drive and 600RRT is screw drive.

**N7.** Aluminum lug for use on aluminum or copper conductors.

DO NOT substitute threaded 03600X lug.

**N8.** Add suffix symbol from page 75 to include cable shield grounding kit and/or cable jacket sealing kit.

**N9.** Copper lug for use with COPPER CONDUCTOR ONLY. DO NOT substitute threaded 03602X lug.

**N10.** Available without the bolt and washers by adding "N" to the part number.

**N11.** Direct test connectors, along with a 200TC-X series meter adapter, a properly rated voltage meter and hot-line stick, provides a means for direct conductor voltage testing. See page 24 for meter adapters.

**N12.** Available with spiking aid option: K656CHSL, K656CYSL and K656IS L and M series.

Refer to the W and X tables on pages 84–85 for sizing to cable insulation diameter and conductor size. For cable shield adapters and jacket seals, see pages 74–75.

## Multi-point junctions

### Molded multi-point junctions

—  
01 J6-622226-25  
—  
02 J6-662266-25-SV

Elastimold® multi-point junctions are available in 2-, 3-, 4-, 5- or 6-point configurations with 15, 25/28 or 35 kV ratings. Units feature modular design flexibility, allowing selection of any combination of 200 A deepwell or 600 A bushing interfaces located on standard 4" or optional 6½" centers. The 6½" center spacing is especially well suited for distributed switchgear applications, including fused elbow, MVI fault interrupter, MVS switch, etc.

Designs incorporate lightweight, damage-resistant, EPDM molded rubber construction and corrosion-resistant 304 stainless steel mounting brackets. Junctions are maintenance free, fully shielded, deadfront and submersible. Units are ideally suited for subsurface, padmount, indoor and outdoor vault applications.

Elastimold multi-point junctions provide a convenient method for connecting, looping and tapping of 200 A and 600 A elbows and other accessories at a common location where utilization of space, cable training, flexibility and operability are important.

### Features

- 15/25/35 kV, 200/600 A molded multipoint junctions
- Fully shielded, fully submersible molded rubber housing
- Uses 304 stainless steel for brackets to prevent rusting and corrosion
- Provides mating for Elastimold elbow connectors, both 600 A and 200 A
- Increases flexibility and operational ability by saving space in crucial areas
- Optional bails available for 200 A deadbreak application

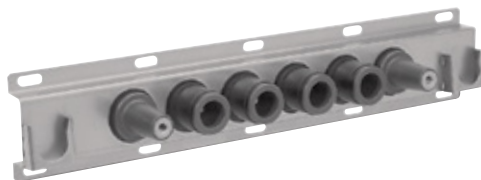

01

### Ratings overview

See pages 4–5 for complete information

#### Current ratings

- 600 A continuous
- 25 kA sym., 10 cycles

#### Or with 200-amp bushing well versions

- 200 A continuous
- 10 kA sym., 10 cycles

#### Voltage ratings

##### 15 kV class

- 8.3 kV phase-to-ground
- 95 kV BIL
- 34 kV AC withstand
- 53 kV DC withstand
- 11 kV corona extinction

##### 25/28 kV class

- 16.2 kV phase-to-ground
- 140 kV BIL
- 45 kV AC withstand
- 84 kV DC withstand
- 21.5 kV corona extinction

##### 35 kV class

- 21.1 kV phase-to-ground
- 150 kV BIL
- 50 kV AC withstand
- 103 kV DC withstand
- 26 kV corona extinction



02



# Multi-point junctions

## Molded multi-point junctions

01 Figure 1: Multi-point junctions with 4" interface spacings.

02 Figure 2: Multi-point junctions with 6½" interface spacings.

### Dimensional information

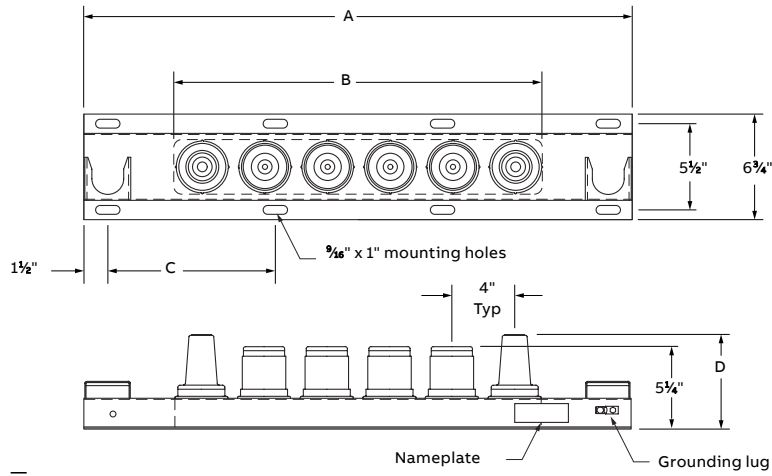

01

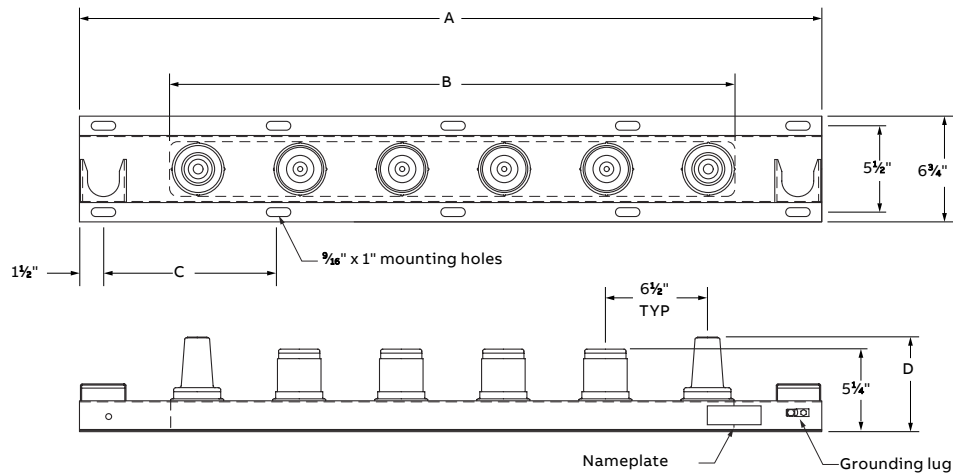

02

Type of junction	Figure 1				Figure 2			
	Dimensions (in.)			Number of mounting holes	Dimensions (in.)			Number of mounting holes
A	B	C	A		B	C		
J2	15	7½	6	6	19½	10	8¼	6
J3	19	11½	8	6	26	16½	11½	6
J4	24	15½	10	6	32½	23	9¾	8
J5	27	19½	12	6	39	29½	12	8
J6	31	23½	9¾	8	45½	36	8¾	10

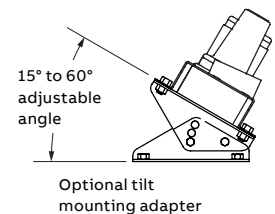





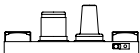

## Multi-point junctions

### Molded multi-point junctions

Elastimold® multi-point junctions feature modular design flexibility that permits the specifier to determine the positions of the bushing interfaces and bushing well positions.

—  
Base catalog numbers

Image (not to scale)	Description	Voltage class (kV)	Cat. no.		Notes
			4" spacing	6½" spacing	
	2-point junction	15	J2 - ____ - 15	J2 - ____ - 15-SV	N1, 2
		25/28	J2 - ____ - 25	J2 - ____ - 25-SV	
		35	J2 - ____ - 35	J2 - ____ - 35-SV	
	3-point junction	15	J3 - _____ - 15	J3 - _____ - 15-SV	N1, 2
		25/28	J3 - _____ - 25	J3 - _____ - 25-SV	
		35	J3 - _____ - 35	J3 - _____ - 35-SV	
	4-point junction	15	J4 - _____ - 15	J4 - _____ - 15-SV	N1, 2
		25/28	J4 - _____ - 25	J4 - _____ - 25-SV	
		35	J4 - _____ - 35	J4 - _____ - 35-SV	
	5-point junction	15	J5 - _____ - 15	J5 - _____ - 15-SV	N1, 2
		25/28	J5 - _____ - 25	J5 - _____ - 25-SV	
		35	J5 - _____ - 35	J5 - _____ - 35-SV	
	6-point junction	15	J6 - _____ - 15	J6 - _____ - 15-SV	N1, 2
		25/28	J6 - _____ - 25	J6 - _____ - 25-SV	
		35	J6 - _____ - 35	J6 - _____ - 35-SV	
	5-point junction	25/28	J5 - 66666 - 25CU	-	N2, 3
		35	J5 - 66666 - 35CU		
	6-point junction	25/28	J6 - 666666 - 25CU	-	N2, 3
		35	J6 - 666666 - 35CU		

**N1.** The 6½" wide spacing is necessary if the junction is to be used to connect with a single-phase MVS molded vacuum switch or MVI molded vacuum interrupter.

**N2.** Also available with a shorter bracket by reducing the number of parking stands; see R, L, N in options.

**N3.** Copper conductor for 900 A rating. Use suffix "CU" at the end of the catalog number.

## Multi-point junctions

### Ordering information

To specify and order Elastimold® multi-point junctions: Use Table 1 to construct a catalog number describing the required junction.

#### Ordering example A

To order a 4-point, 15 kV junction with 4" spacings and 600 series interfaces on the outside ways and 200 A wells on the inside ways, specify catalog number J4-6226-15.

#### Ordering example B

To order a 6-point, 25/28 kV junction with 6½" spacings and 600 series interfaces on ways 1, 3, 4 and 6 and 200 A wells on the ways 2 and 5, specify catalog number J6-626626-25-SV.

Table 1. Catalog number construction

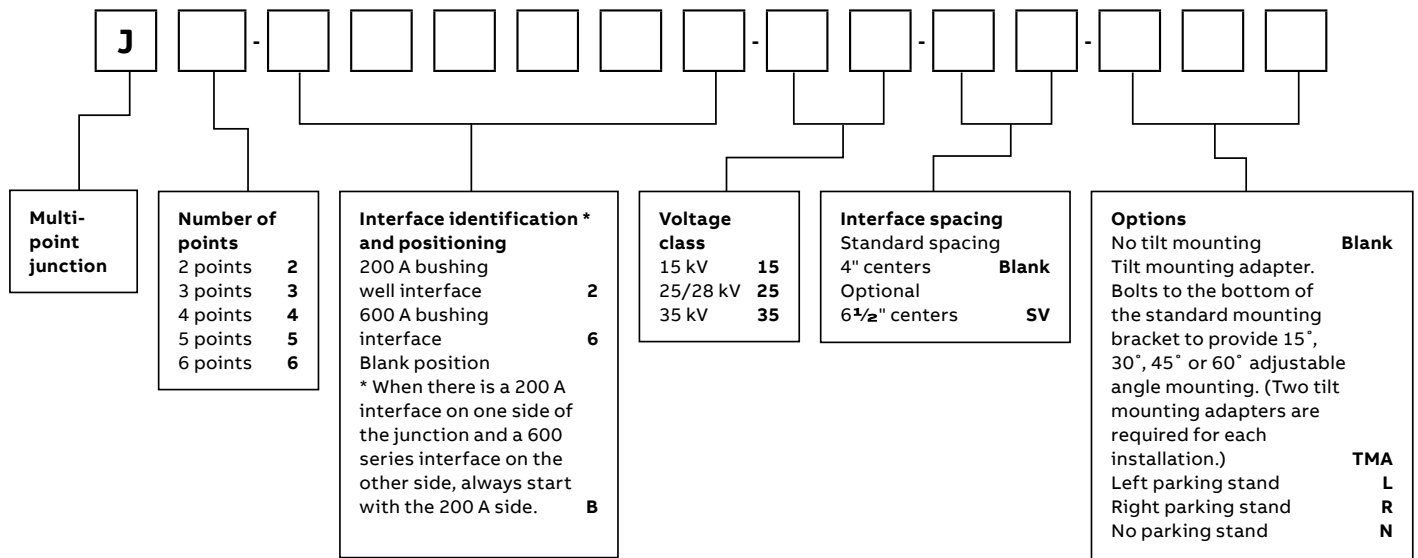

## ComboT integral separable connectors

—  
01 ComboT CETP  
installed.

—  
02 ComboT CCP installed.

—  
ComboT provides the shortest elbow stack height and the most reliable assembly in the industry.

### The shortest stack height in the industry – Works in smaller cabinets and installs in tighter spaces

- Shortest stack height – Each combination elbow/connecting plug reduces stack height 2.67"
- Eliminates blind assembly – Simple connection system reduces the chance of cross threading and is easier to line up and install
- Fewer interfaces and reduced inventory – Combination elbow reducing taps, connecting and bushing well plugs

- Installs with your standard assembly tools – unique conductive component and uses standard 600 or 900 series stud
- Ensures proper installation torque – Internal hex broach
- IEEE 386 color-coded PBT interfaces – Red for 15 kV reducing tap and blue for 25 kV reducing tap; provide better visibility and seating indication, plus reduces sticking
- 25 kV reducing tap with vents – prevents partial-vacuum flashover



—  
01

—  
02

## ComboT integral separable connectors

### Ratings

#### Simple design, simple assembly

The 15 kV CETP and 15/25 kV CCP simple design makes assembly quick and easy, using a standard  $\frac{3}{8}$ "-11 stud that is threaded into the equipment bushing. The hollow bore of the ComboT allows visual validation that the compression lug is positioned properly before the snuffer/bus is inserted and tightened. If preferred, the stud may be first threaded into the snuffer/bus.

Again, the hollow bore of the ComboT allows visual validation that the compression lug is correctly positioned before proceeding. This is all accomplished with the same parts in a ComboT kit. There is no need to choose "male fastener" or "female fastener" when ordering.

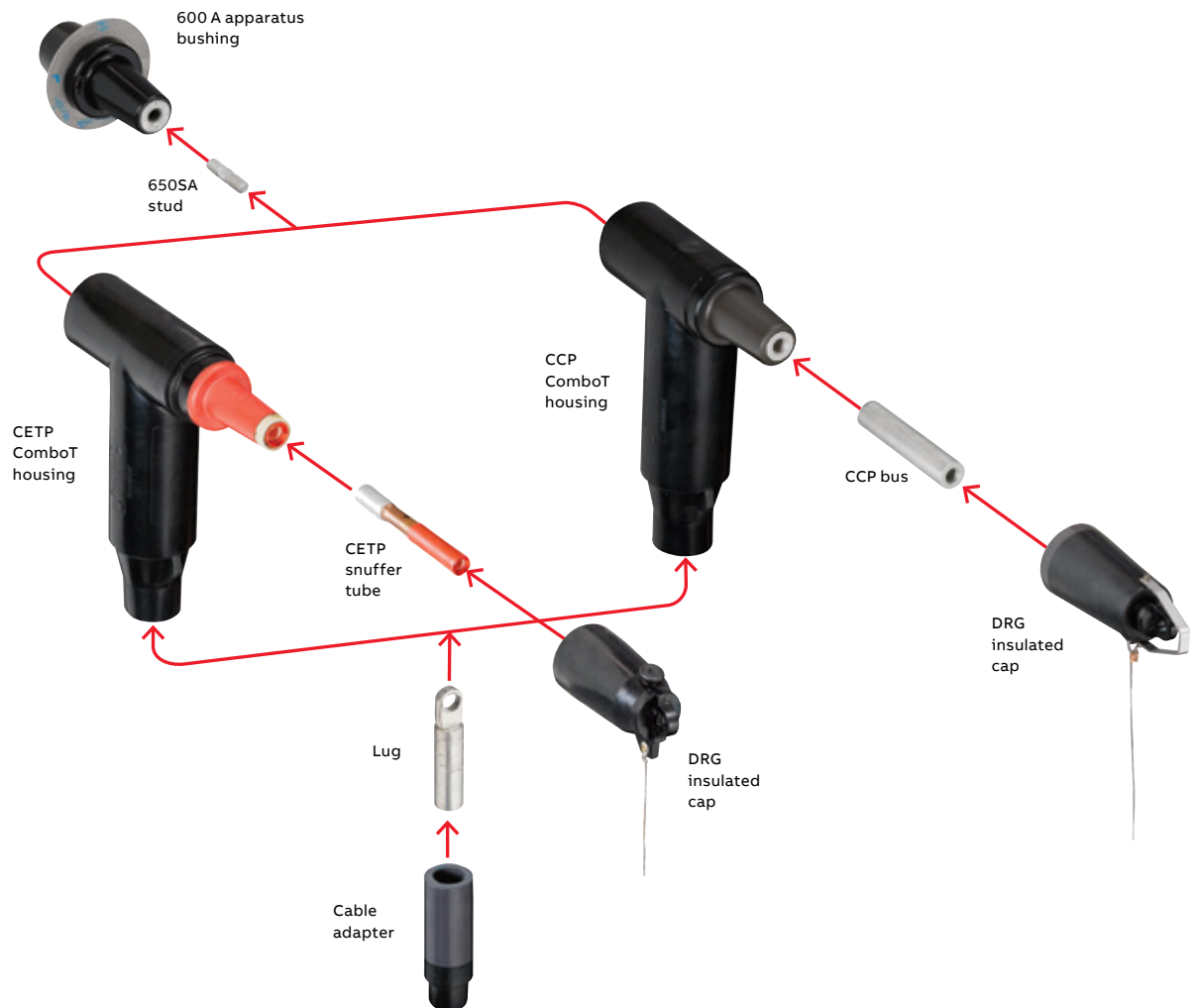



—  
Ratings





Base catalog series	Deadbreak with loadbreak reducing tap							
	655/656CETP series 600 A deadbreak		675/676CETP series 900 A deadbreak		K655/K656CETP series 600 A deadbreak		K675/K676CETP series 900 A deadbreak	
	600 A DB	200 A LB	900 A DB	200 A LB	600 A DB	200 A LB	900 A DB	200 A LB
Voltage class (kV)	15	–	15	–	25	–	25	–
Max. phase-to-ground operating voltage (kV)	8.3	–	8.3	–	15.2	–	15.2	–
Max. phase-to-phase operating voltage (kV)	14.4	–	14.4	–	26.3	–	26.3	–
BIL – Impulse withstand (1.2 x 50 microsecond wave) (kV)	95	–	95	–	125	–	125	–
AC – One-minute withstand voltage (kV)	34	–	34	–	40	–	40	–
DC – 15-minute withstand voltage (kV)	53	–	53	–	78	–	78	–
Corona extinction level @ 3.0 pC sensitivity (kV)	11	–	11	–	19	–	19	–
Interface/connection	600 A DB	200 A LB	900 A DB	200 A LB	600 A DB	200 A LB	900 A DB	200 A LB
Continuous current (A)	600	200	900	200	600	200	900	200
Loadmake/loadbreak switching current (A)	–	200	–	200	–	200	–	200
Symmetrical momentary current – 10 cycle (kA)	25	10	25	10	25	10	25	10
Symmetrical one-time fault close current – 10 cycle (kA)	–	10	–	10	–	10	–	10
Symmetrical momentary current – 3 second (kA)	10	3.5	10	3.5	10	3.5	10	3.5

—  
Ratings

Base catalog series	Deadbreak with connecting plug		Deadbreak with bushing well	
	K655K656 CCP series 600 A deadbreak	K675K676 CCP series 900 A deadbreak	K655K656 CBW series 600 A deadbreak	K675K676 CBW series 900 A deadbreak
	15/25/28	15/25/28	15/25/28	15/25/28
Voltage class (kV)	15/25/28	15/25/28	15/25/28	15/25/28
Max. phase-to-ground operating voltage (kV)	16.2	16.2	16.2	16.2
Max. phase-to-phase operating voltage (kV)	28.0	28.0	28.0	28.0
BIL – Impulse withstand (1.2 x 50 microsecond wave) (kV)	140	140	140	140
AC – One-minute withstand voltage (kV)	45	45	45	45
DC – 15-minute withstand voltage (kV)	84	84	84	84
Corona extinction level @ 3.0 pC sensitivity (kV)	21.5	21.5	21.5	21.5
Continuous current (A)	600	900	600	900
Symmetrical momentary current – 10 cycle (kA)	25	25	25	25
Symmetrical momentary current – 3 second (kA)	10	10	10	10

## ComboT integral separable connectors









































### ComboT integral separable connectors

Description	kV class	Test point	Continuous current, amps	Connector: universal aluminum, copper or bi-metal	Cat. no.	Notes	Basic ComboT elbow with bus and stud
							Kit not to scale
ComboT elbow/ reducing tap plug	15	No	600	U-AL	655BCETP	–	 (No test point; aluminum shown)
			900	CU	675BCETP	1	
			900	BM	675BCETP	1	
	Yes	600	U-AL	656BCETP	–		
		900	CU	676BCETP	1		
		900	BM	676BCETP	1		
ComboT elbow/ reducing tap plug	25	No	600	U-AL	K655BCETP	–	 (Test point; aluminum shown)
			900	CU	K675BCETP	1	
			900	BM	K675BCETP	1	
	Yes	600	U-AL	K656BCETP	–		
		900	CU	K676BCETP	1		
		900	BM	K676BCETP	1		
ComboT elbow/ connecting plug	15/25	No	600	U-AL	K655BCCP	–	 (No test point; aluminum shown)
			900	CU	K675BCCP	1	
			900	BM	K675BCCP	1	
	Yes	600	U-AL	K656BCCP	–		
		900	CU	K676BCCP	1		
		900	BM	K676BCCP	1		
ComboT elbow/ bushing well	15/25	No	600	U-AL	K655BCBW	–	 (Test point; aluminum shown)
			900	CU	K675BCBW	1	
			900	BM	K675BCBW	1	
	Yes	600	U-AL	K656BCBW	–		
		900	CU	K676BCBW	1		
		900	BM	K676BCBW	1		

Notes: 1. 900 A continuous is based on an all-copper system: bushing, stud, tang of the lug, contact of the plug and a cable of equal rating.

2. W and X vary with medium-voltage cable being used, with W based on the insulation diameter and X on the conductor size and construction. See page 62 for specifics.

ComboT integral separable connectors

ComboT Elbow with bus, stud, cable adapter and lug kit			ComboT elbow with bus, stud, cable adapter, lug and insulated cap kit		
Cat. no.	Notes	Kit not to scale	Cat. no.	Notes	Kit not to scale
655CETPW0X	2	(No test point; aluminum shown)	655CETPW0XDRG	2	(No test point; aluminum shown)
675CETPW2X	1, 2		675CETPW2XDRG	1, 2	
675CETPW5X	1, 2		675CETPW5XDRG	1, 2	
656CETPW0X	2		656CETPW0XDRG	2	
676CETPW2X	1, 2		676CETPW2XDRG	1, 2	
676CETPW5X	1, 2		676CETPW5XDRG	1, 2	
<hr/>			<hr/>		
655CETPW0X	2	(Test point; aluminum shown)	655CETPW0XDRG	2	(Test point; aluminum shown)
K675CETPW2X	1, 2		K675CETPW2XDRG	1, 2	
K675CETPW5X	1, 2		K675CETPW5XDRG	1, 2	
K656CETPW0X	2		K656CETPW0XDRG	2	
K676CETPW2X	1, 2		K676CETPW2XDRG	1, 2	
K676CETPW5X	1, 2		K676CETPW5XDRG	1, 2	
<hr/>			<hr/>		
655CCPW0X	2	(No test point; aluminum shown)	655CCPW0XDRG	2	(No test point; aluminum shown)
675CCPW2X	1, 2		675CCPW2XDRG	1, 2	
675CCPW5X	1, 2		675CCPW5XDRG	1, 2	
K656CCPW0X	2		K656CCPW0XDRG	2	
K676CCPW2X	1, 2		K676CCPW2XDRG	1, 2	
K676CCPW5X	1, 2		K676CCPW5XDRG	1, 2	
<hr/>			<hr/>		
655CBWW0X	2	(Test point; aluminum shown)	655CBWW0XBWP	2	(Test point; aluminum shown)
K675CBWW2X	1, 2		K675CBWW2XBWP	1, 2	
K675CBWW5X	1, 2		K675CBWW5XBWP	1, 2	
K656CBWW0X	2		K656CBWW0XBWP	2	
K676CBWW2X	1, 2		K676CBWW2XBWP	1, 2	
K676CBWW5X	1, 2		K676CBWW5XBWP	1, 2	

Notes: 1. 900 A continuous is based on an all-copper system: bushing, stud, tang of the lug, contact of the plug and a cable of equal rating.  
 2. W and X vary with medium-voltage cable being used, with W based on the insulation diameter and X on the conductor size and construction. See page 62 for specifics.



# ComboT integral separable connectors

## Ordering information

The following diagram shows how to construct a catalog number for a ComboT.

Indicates field that must be filled in to complete the catalog number.

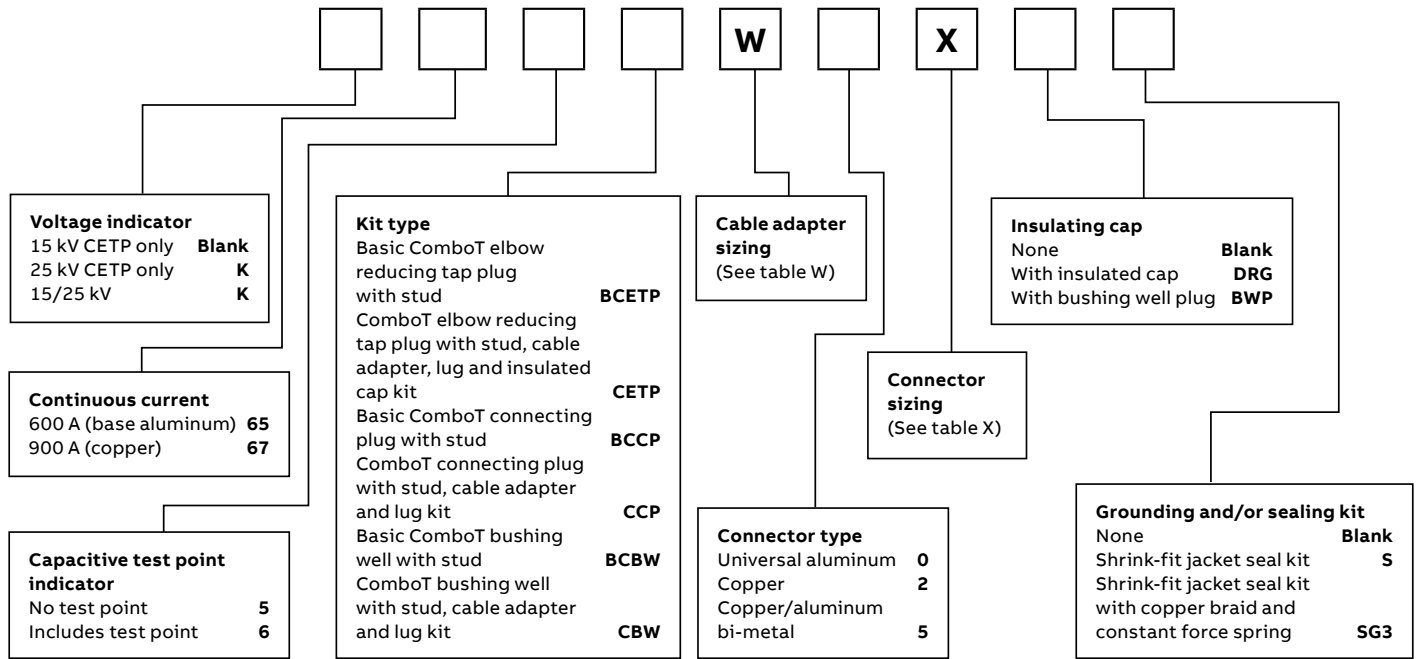

Table W – Cable adapter sizing

Cable insulation dia. range				
Inches		mm		Symbol for W
Min.	Max.	Min.	Max.	
0.640	0.820	16.3	20.8	F
0.760	0.950	19.3	24.1	G
0.850	1.050	21.6	26.7	H
0.980	1.180	24.9	30.0	J
1.090	1.310	27.7	33.3	K
1.180	1.465	30.0	37.2	L
1.280	1.430	32.5	36.3	LM
1.370	1.630	34.8	41.4	M
1.550	1.780	38.5	45.2	N
1.725	1.935	43.8	49.1	P

Table X – Connector sizing

AWG or kcmil		mm <sup>2</sup>		X code
Stranded/compressed	Solid/compact	Compact only		
–	2	25		210
2	1	35		220
1	1/0	50		230
1/0	2/0	–		240
2/0	3/0	70		250
3/0	4/0	95		260
4/0	250	125		270
250	300	–		280
300	350	150		290
350	400	185		300
400	450	240		310
450	500	–		320
500	600	300		330
650	750	400		360
750	900	–		380
900	1000	500		400
1000	–	–		410
–	1250	630		420
1250	–	–		440

## Permanent distribution cable joints

### PCJ™ power cable joints

PCJ power cable joints use permanently crimped connectors. PCJ housings are fully insulated, shielded and sealed for direct-burial, vault, submersible and other severe service applications. Units have been designed and tested per IEEE Standard 404 to ensure system-matched performance and ratings equal to the cable to which the splice will be installed.

#### PCJ power cable joints are available in two styles:

Style 1 uses a single-piece housing that is sized to accommodate a specific range of cable. Style 1 units are ideally suited for straight splicing of the same or similar cable.

Style 2 designs incorporate a universal housing with separate cable adapters to allow transition splices of different types and sizes of cable.

### Electrical ratings summary

The following ratings summary is based on IEEE 404 and applies to all Elastimold PCJ power cable joints.

#### Voltage

- A. 15 kV class (8.7 kV phase-to-ground)
- B. 25 kV class (14.4 kV phase-to-ground)
- C. 35 kV class (20.2 kV phase-to-ground)
- Impulse withstand: A = 110 kV, B = 150 kV, C = 200 kV BIL, 1.2 x 50 microsecond wave
- Corona extinction voltage: A = 13 kV, B = 22 kV, C = 30 kV minimum, 3 pC sensitivity
- DC withstand: During installation, A = 56 kV, B = 80 kV, C = 100 kV
- DC withstand: After installation and in service for the first 5 years, A = 18 kV, B = 25 kV, C = 31 kV for XLPE insulated cables and A = 45 kV, B = 64 kV, C = 80 kV for EPR insulated cables (reference AEIC CS6 and CS8, Section L.2)

#### Current

Continuous rating equal to the rating of the cable  
Short-time rating equal to the rating of the cable up to 35 kA

#### Shield design

- Meets IEEE 592 for exposed semiconducting shields on premolded high voltage cable joints and separable insulated connectors

#### Production tests include 100% tests of the premolded joints to ensure:

- Corona extinction voltage: A = 13 kV, B = 22 kV, C = 30 kV minimum, 3 pC sensitivity
- AC withstand: A = 35 kV, B = 52 kV, C = 69 kV, 60 Hz, 1 minute

#### Design tests on production joints demonstrate compliance with IEEE 404 including:

- Corona extinction voltage: A = 13.0 kV, B = 22.0 kV, C = 30.0 kV minimum, 3 pC sensitivity
- AC withstand: A = 35 kV, B = 52 kV, C = 69 kV, 60 Hz, 1 minute
- DC withstand: A = 75 kV, B = 105 kV, C = 140 kV negative polarity, 15 minutes
- Impulse withstand (BIL): A = 110 kV, B = 150 kV, C = 200 kV, 10 positive and 10 negative, 1.2 x 50 microsecond wave, at conductor temperatures of 20 °C and 130 °C, nominal
- Short-time current: Magnitude equal to cable up to 35 kA
- Cyclic aging: 30 days at A = 26 kV, B = 43 kV, C = 61 kV AC continuous, load current for 8 hours per day, providing 130 °C conductor temperature; joints then subjected to A = 31 kV, B = 50 kV, C = 71 kV for 5 hours followed by A = 39 kV, B = 65 kV, C = 91 kV for 5 min
- Load cycle: Connectors meet requirements of ANSI C119.4, Class A and Class 3 ratings

## Permanent distribution cable joints

### PCJ™ power cable joints

#### PCJ style 1

With single-piece housing

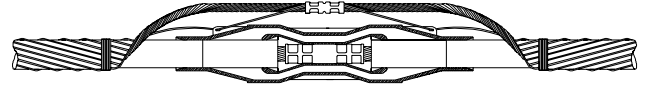

#### PCJ style 2

With universal housing and separate cable adapters that can be varied with the cable application

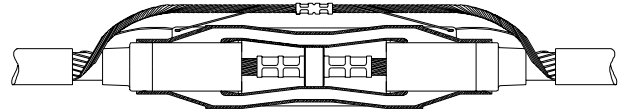

#### Ordering information

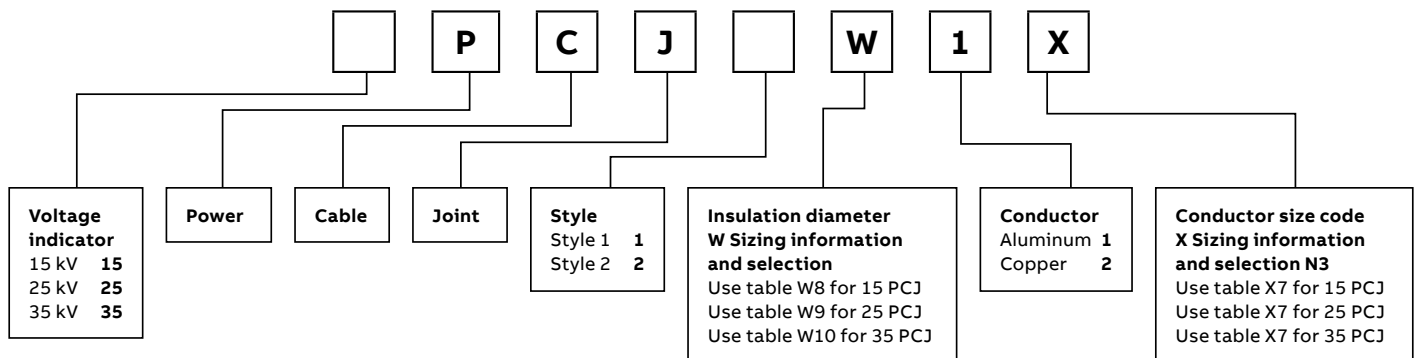

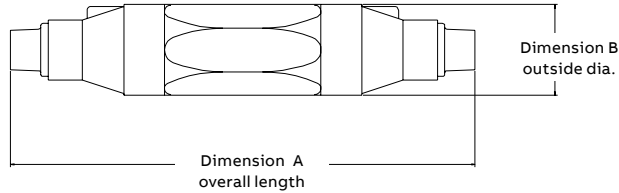

**Dimensional data**

Style 1 Cat. no.	A inches	B inches
15PCJ1FX	10 <sup>3</sup> / <sub>4</sub>	1 <sup>3</sup> / <sub>4</sub>
15PCJ1GX	10 <sup>3</sup> / <sub>4</sub>	1 <sup>3</sup> / <sub>4</sub>
25PCJ1GX	14 <sup>3</sup> / <sub>8</sub>	2 <sup>7</sup> / <sub>16</sub>
15/25/35PCJ1HX	14 <sup>3</sup> / <sub>8</sub>	2 <sup>7</sup> / <sub>16</sub>
15/25/35PCJ1JX	14 <sup>3</sup> / <sub>8</sub>	2 <sup>7</sup> / <sub>16</sub>
15/25/35PCJ1KX	14 <sup>3</sup> / <sub>8</sub>	2 <sup>25</sup> / <sub>32</sub>
15/25/35PCJ1LX	14 <sup>3</sup> / <sub>8</sub>	2 <sup>25</sup> / <sub>32</sub>
15/25PCJ1LMX	14 <sup>3</sup> / <sub>8</sub>	2 <sup>25</sup> / <sub>32</sub>
15/25/35PCJ1MX	14 <sup>3</sup> / <sub>8</sub>	2 <sup>25</sup> / <sub>32</sub>
15/25/35PCJ1NX	15 <sup>3</sup> / <sub>4</sub>	3 <sup>3</sup> / <sub>16</sub>
15/25/35PCJ1PX	15 <sup>3</sup> / <sub>4</sub>	3 <sup>3</sup> / <sub>16</sub>
15/25/35PCJ1QX	15 <sup>3</sup> / <sub>4</sub>	3 <sup>3</sup> / <sub>16</sub>

**Dimensional data**

Style 2 Cat. no.	A inches	B inches
15PCJ2FX	16 <sup>3</sup> / <sub>8</sub>	2 <sup>25</sup> / <sub>32</sub>
15/25PCJ2GX	16 <sup>3</sup> / <sub>8</sub>	2 <sup>25</sup> / <sub>32</sub>
15/25/35PCJ2HX	16 <sup>3</sup> / <sub>8</sub>	2 <sup>25</sup> / <sub>32</sub>
15/25/35PCJ2JX	16 <sup>3</sup> / <sub>8</sub>	2 <sup>25</sup> / <sub>32</sub>
15/25/35PCJ2KX	21	3 <sup>3</sup> / <sub>4</sub>
15/25/35PCJ2LX	21	3 <sup>3</sup> / <sub>4</sub>
15/25/35PCJ2MX	21	3 <sup>3</sup> / <sub>4</sub>
15/25/35PCJ2NX	21	3 <sup>3</sup> / <sub>4</sub>
15/25/35PCJ2PX	21	3 <sup>3</sup> / <sub>4</sub>
15/25/35PCJ2QX	21	3 <sup>3</sup> / <sub>4</sub>

**PCJ power cable joint**

Description	Voltage class (kV)	Cat. no.	Notes
Power cable joint Style 1	15	15PCJ1W1X	N1
	15	15PCJ1W2X	N2
	25	25PCJ1W1X	N1
	25	25PCJ1W2X	N2
	35	35PCJ1W1X	N1
	35	35PCJ1W2X	N2
Power cable joint Style 2	15	15PCJ2W1X	N1
	15	15PCJ2W2X	N2
	25	25PCJ2W1X	N1
	25	25PCJ2W2X	N2
	35	35PCJ2W1X	N1
	35	35PCJ2W2X	N2

- N1.** Kit includes aluminum compression connector suitable for splicing aluminum conductor to aluminum conductor or aluminum conductor to copper conductor. An all-copper connector is required for copper-to-copper connections.
- N2.** Kit includes copper compression connector suitable for splicing copper conductors to copper conductor only. DO NOT use copper connectors on aluminum conductors.
- N3.** When constructing a catalog number for a transition (two different-size cables) joint, list the larger connector first and the smaller connector second.

Refer to the W and X tables on pages 84–85 for sizing to cable insulation diameter and conductor size. For cable shield adapters and jacket seals, see pages 74–75.

## Distribution shrink-fit terminations

### Ranger2™ terminations

- Silicone polymer housing provides superior memory and weathering characteristics
- Shrink-fit housing uses common installation procedures and cable preparation dimensions, and field-removable center core allows for easy installation
- Three different shed designs for superior weathering:
  - Four sheds for 15 kV outdoor model
  - Six sheds for 25/28 kV outdoor model
  - Eight sheds for 35 kV outdoor model
- Three sizes cover entire cable range from #2 AWG to 1250 kcmil
- Units accommodate popular XLP and EPR cable types and various shield constructions
- Integral Hi-K voltage stress-control tube provides uniform voltage grading over the length of the termination and eliminates damaging voltage stress concentrations at the cable insulation shield edge
- Thick wall construction securely maintains critical interface pressure for consistent long-term reliability and performance
- Pull-down tabs for easy installation of built-in jacket seal – Accommodate CN, JCN, tape, wire or LC shielded cable construction
- Lightweight, compact design installs in restricted spaces and permits application where free hanging is desired
- Dark gray molded silicone insulator uses specially formulated silicone materials with improved UV stability, track, erosion and weather resistance for enhanced performance under the worst environmental conditions
- Optional connectors with copper stem and one-hole or two-hole spade
- Optional cable and support bracket with three sizes ranging from 0.80"–2.40" O.D.

### Silicone polymer housings

The R2T and R2IT terminations are manufactured using an optimized weather-resistant silicone formulation. The housing offers superior cable sealing and voltage withstand characteristics.

Elastimold® terminations meet or exceed all requirements of IEEE 48 for Class 1 outdoor or Class 2 indoor terminations. Unit tests include voltage withstand wet and dry, before and after load cycling on units installed on maximum conductor sized cable.

#### Kit contents

Every R2T and R2IT comes complete with housing and stress tube preassembled on the core, ready for installation. Easy-to-read installation instructions will take you from cable preparation through installation. All kits include a tube of silicone grease, two plastic gloves and two strips of self-fusing silicone tape. Outdoor kits also include mastic for sealing. Metallic tape (M) kits include a grounding adapter for tape shield, wire shield and unshield cables. LC shield (L) kits include a high ampacity grounding adapter for longitudinally corrugated shield, tape shield and wire over tape shield cables.

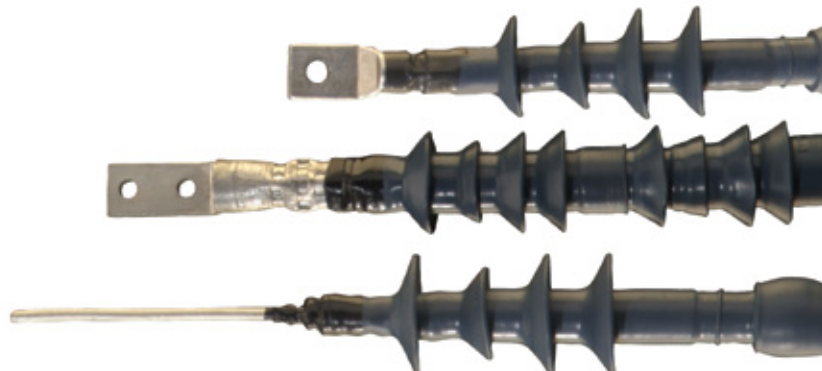

—  
Stress relief

The R2T and R2IT terminations provide electric stress control for the cable by means of a flexible tube with a high permittivity dielectric constant.

The stress-relief tube is preassembled on the core under the polymer housing. As the core is removed, the stress-relief tube and housing shrink onto the cable at the same time, in exactly the right position. No secondary operations are required during installation. The electrical fields are refracted through the high dielectric constant tube and housing as shown.

—  
Installation

Standard cable preparation techniques are used for all R2T Elastimold Ranger2 outdoor terminations and R2IT Elastimold Ranger2 indoor terminations. The Elastimold shrink-fit terminations are assembled on a removable core. After the termination is placed onto the prepared cable, the core is removed by pulling on the end. The housing then collapses onto the prepared cable. Memory of the material provides the interface solid dielectric and sealing properties required to meet the electrical ratings and prevent the ingress of moisture.

—  
Certified

Elastimold Ranger2 terminations have been designed and tested per applicable portions of ANSI, IEEE, AEIC, ICEA and other industry standards.

**IEEE 48**

Standard for indoor and outdoor cable terminations.

**ANSI C119.4**

Standard for cable connectors for aluminum and copper conductors.

**AEIC CS8-06 and ANSI/ICEA S-94-649-2004 and S-97-682-2000**

Standards for XLP and EPR insulated cables.

—  
Voltage stress

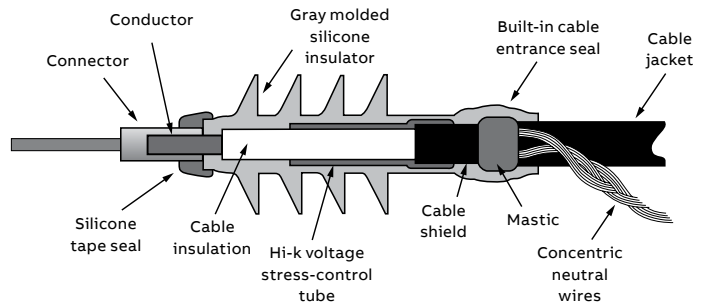
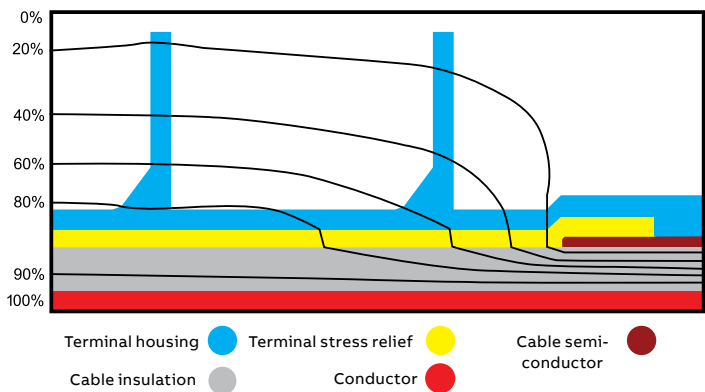

## Distribution shrink-fit terminations

### Ranger2™ terminations

#### Ratings

	R2IT15 indoor	R2T15 outdoor	R2T28 outdoor	R2T35 outdoor
Sizes available*	1, 2, 4	1, 2, 4	2, 4	2, 4
Voltage rating (kV)	15	15	25/28	35
Max. design voltage to ground (kV)	9.5	9.5	16	22
Corona extinction voltage (kV) ( $\leq 3$ pC) (partial discharge)	13	13	22	30
<b>Insulation withstand voltage:</b>				
Lightning impulse (BIL dry 110 withstand) (kV crest)	110	110	150	200
10 Sec. wet (60 Hz) (kV)	–	45	60	80
1 Minute dry (60 Hz) (kV)	50	50	65	90
5 Hour dry (60 Hz) (kV)	35	35	55	75
DC withstand 15 min. dry (kV)	75	75	105	140

#### Application information

IEEE 48 classification	Outdoor = Class 1A, indoor = Class 2
Ambient temperature range	-30 °C to 65 °C
Power system frequency	48 to 62 Hz
Altitude range	3,300 feet max.
Mounting	Free hanging or optional bracket

#### Dimensions



	R2IT15 indoor	R2T15 outdoor	R2T28 outdoor	R2T35 outdoor
Sizes available*	1, 2, 4	1, 2, 4	2, 4	2, 4
Voltage rating (kV)	15	15	25/28	35
Number of sheds	0	4	6	8
Minimum strike distance in. (mm)	8.4 (213)	11.6 (295)	14.5 (368)	16.8 (427)
Cree distance in. (mm)	8.4 (213)	15.0 (381)	22.8 (579)	30.0 (762)

\* See pages 80–82 for cable insulation diameter ranges.

The R2T and R2IT termination design couples shrink-fit technology and Elastimold®'s pull-down jacket seal feature to provide a termination line that covers the widest range of applications with the fewest number of models. Three sizes cover 0.64" (16 mm) to 2.10" (53 mm) insulation diameter cables (#2 AWG through 1250 kcmil).

The R2T housings are designed for maximum performance in all field conditions with superior cree and strike distances for long-term service. Insulating silicone sleeves are also available when more cree is required or when wildlife protection is needed to insulate the connectors. Contact your ABB sales representative for further information.

**Ranger2 terminations base catalog numbers**



				Cable range (insulation diameter)		Concentric neutral and jacketed concentric neutral cable	Tape shield, wire shield and unishield cable	LC shield, wire over tape shield and tape shield cable	Cat. no.
	kV class	kV class	Inches	mm					
	15	Indoor	0.64 to 1.12	16.3 to 28.4	R2IT15J1	R2IT15M1	R2IT15L1		
			0.84 to 1.38	21.3 to 35.1	R2IT15J2	R2IT15M2	R2IT15L2		
			1.30 to 2.10	33.0 to 53.3	R2IT15J4	R2IT15M4	R2IT15L4		
	15	Outdoor	0.64 to 1.12	16.3 to 28.4	R2T15J1	R2T15M1	R2T15L1		
			0.84 to 1.38	21.3 to 35.1	R2T15J2	R2T15M2	R2T15L2		
			1.30 to 2.10	33.0 to 53.3	R2T15J4	R2T15M4	R2T15L4		
	25/28	Outdoor	0.84 to 1.38	20.3 to 35.1	R2T28J2	R2T28M2	R2T28L2		
			1.30 to 2.10	33.0 to 53.3	R2T28J4	R2T28M4	R2T28L4		
	35	Outdoor	0.84 to 1.38	20.03 to 35.1	R2T35J2	R2T35M2	R2T35L2		
			1.30 to 2.10	33.0 to 53.3	R2T35J4	R2T35M4	R2T35L4		



## Distribution shrink-fit terminations

### Ranger2™ terminations

#### Ranger2 termination connector options

	Type	Material	Conductor	Conductor size	Connector prefix*
	Stem compression connector	Aluminum	Aluminum or copper	#2-4/0 (34-107)	T0
		Aluminum	Aluminum only	#2-4/0 (34-107)	T1
	One-hole spade connector	Tinned aluminum	Aluminum or copper	#2-500 (34-253)	H0
	Two-hole spade connector	Tinned aluminum	Aluminum or copper	#2-1250 (34-633)	N0
		Tinned copper	Copper	#2-1250 (34-633)	N2



\* See page 75 for conductor code.

#### Optional cable support brackets

	Type	Cable range (overall O.D.)	Stainless steel	
			Cat. no.	Suffix number
	Single clamp	0.80"-1.25" (20-32 mm)	JB-1	B1
	Single clamp	1.10"-1.50" (28-38 mm)	JB-2	B2
	Double clamp	1.45"-1.95" (37-50 mm)	JB-3	B3
	Double clamp	1.80"-2.40" (45-61 mm)	JB-4	B4

#### Add-on grounding kits

##### Convert a jacketed concentric neutral "J" kit to an "M" or "L" shield kit

	Cat. no.	Type	Size	Use with series
	GMA	Tape shield/wire shield/unishield	A	R2IT15J1, R2IT15J2, R2T15J1, R2T15J2, R2T28J2, R2T35J2
	GMB	Tape shield/wire shield/unishield	B	R2IT15J4, R2T15J4, R2T28J4, R2T35J4
	GLA	LC shield/wire over tape shield	A	R2IT15J1, R2IT15J2, R2T15J1, R2T15J2, R2T28J2, R2T35J2
	GLB	LC shield/wire over tape shield	B	R2IT15J4, R2T15J4, R2T28J4, R2T35J4

# Distribution shrink-fit terminations

## Ranger2™ terminations

### Ordering information for Ranger2 terminations

Ranger2 terminations may be ordered in components or as complete kits by following the steps outlined and using the model below to develop the catalog number for your application. Contact your local ABB sales representative for special requirements.

Indicates field that must be filled in to complete order. Note: Availability of selected configuration will be verified at quotation time.

The following diagram shows how to construct a catalog number for a Ranger2 termination.

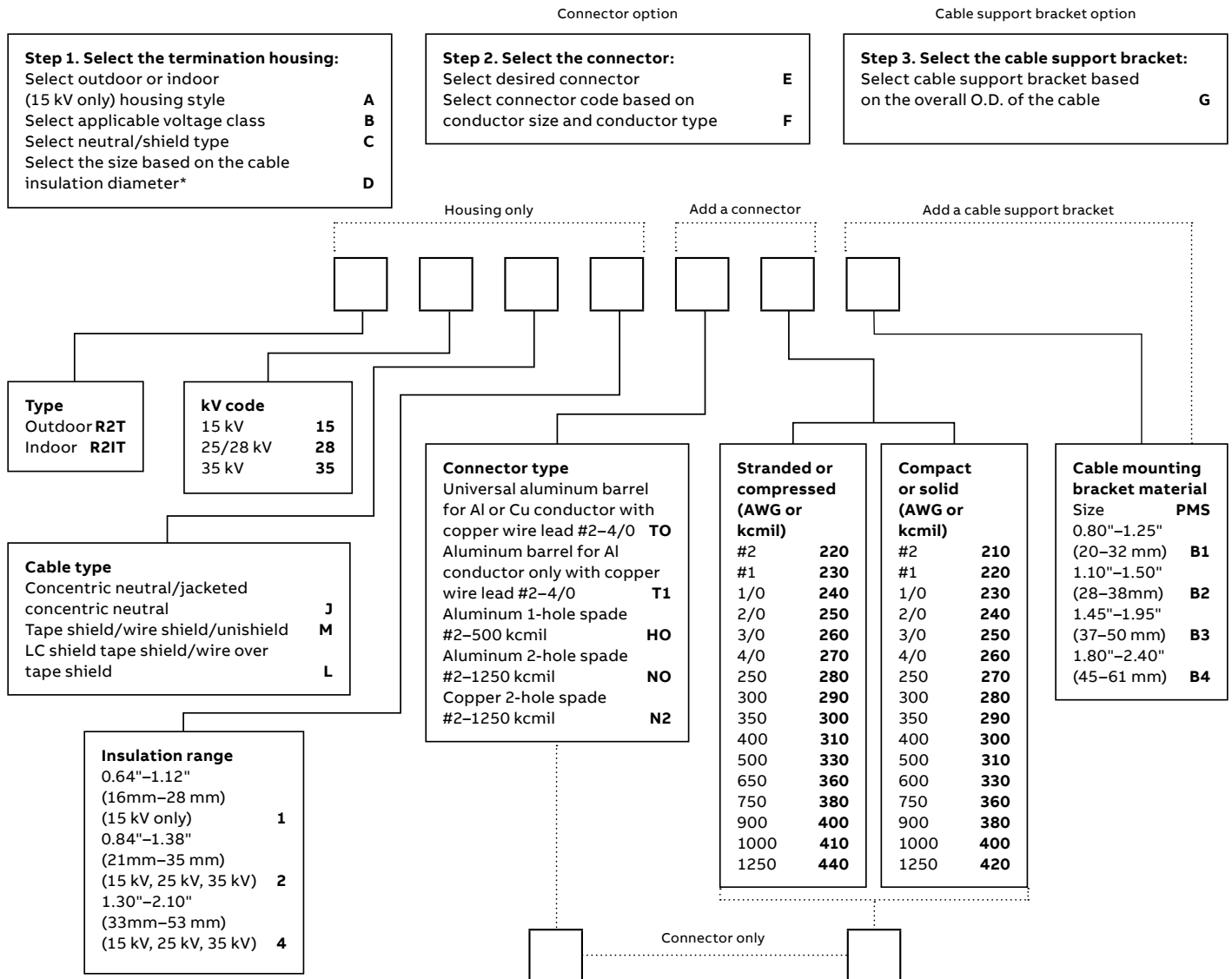

\* To help in selecting the proper terminator, ICEA and AEIC standard dimensions for XLP and EPR cables are on pages 80-82.  
 \*\* In 28 kV, the connector type "NO" is only for insulation range 2 and 4.

## Distribution shrink-fit terminations

### Ranger2™ terminations

01 Train the cable into position and cut to length. Using standard practices, cut back the cable jacket, metallic shield, semi-conductive shield and cable insulation, exposing the conductor.

02 Finish preparing the metallic shield. For concentric neutral or jacketed concentric neutral cables, bend back the neutral wires and seal with mastic strips and vinyl tape. For metallic tape, drain wire, unshield or LC shield cables: install the ground braid using the constant force spring and seal with mastic strips and vinyl tape.

03 Clean the exposed conductor, install and crimp the connector.

04 Use mastic and vinyl tape to fill any gap or step between the connector and the cable insulation. Clean the cable.

05 Apply a liberal bead of silicone lubricant to the semi-con shield step.

06 Pull the loose end of the core cord until the core is even with the end of the termination housing.

07 Position the terminator onto the cable.

08 Shrink into place by unwinding the removable core.

09 Apply silicone lubricant to skirt and mastic area.

10 Fold down the skirt over the mastic to seal the cable entrance.

11 Seal the top of the terminator at the connector area with silicone tape.

12 Attach the neutral wires or optional ground braid to the system ground per local code. Install the optional cable support bracket if required.

#### Typical installation of Elastimold® Ranger2 shrink-fit terminations (R2T – Outdoor and R2IT – Indoor)

**Warning:** Refer to local code for required PPE.



01, 02, 03, 04



05



06



07



08



09



10



11



12

## Pre-molded terminations

### Cable terminations

Elastimold® cable terminations are available in a single-piece design. Terminators allow connection and transition from shielded, underground cable to bare overhead conductors and live-front equipment. Units are designed and rated per IEEE 48 for riser pole, padmount, indoor and outdoor applications. PCT1 and PCT2 terminators provide sufficient creep, strike and weather sealing for Class 1 outdoor service. PCT1 and PCT2 also include an integral cable jacket seal.

#### Voltage ratings

##### 15 kV class

- 9.5 kV phase-to-ground
- 110 kV BIL 1.2 x 50 microsecond wave
- AC withstand:
  - 50 kV 1 min. – Dry
  - 35 kV 6 hr. – Dry
  - 45 kV 10 sec. – Wet
- 13 kV corona extinction

##### 25 kV class

- 16 kV phase-to-ground
- 150 kV BIL 1.2 x 50 microsecond wave
- AC withstand:
  - 65 kV 1 min. – Dry
  - 55 kV 6 hr. – Dry
  - 60 kV 10 sec. – Wet
- 21.5 kV corona extinction

### Electrical ratings summary

The following ratings summary is based on IEEE Standard 48 and applies to all the terminations on this . Elastimold terminations are designed for use on three-phase systems, either 3-wire or 4-wire, and the single-phase laterals of these systems.

#### Cable terminations

	Description	Voltage class (kV)	Cat. no.	Notes
	Single-piece terminator (class 1)	15	PCT1-1X-4 Use table X9	N2, 3, 4, 5
		25	PCT2-1X-4 Use table X9	N2, 3, 4, 6
	Housing only	15	PCT1-4	N5
		25	PCT2-4	N6
	Rod contact for PCT	15/25	00700X Use table X9	N1, 3, 4
	Two-hole spade for PCT	All	01000X Use table X9	N1
	One-hole spade for PCT	All	01100X Use table X9	N1
	PCT positioning bracket	All	PB-1	N1, 7

- N1.** Use with PCT1 or PCT2 terminators.
- N2.** Includes rod contact as standard. Specify suffix "-3" in place of "-4" for two-hole spade lug. Specify suffix "-5" in place of "-4" for one-hole spade lug.
- N3.** Use 1X for an aluminum rod contact for aluminum conductors only.
- N4.** Substitute 0X for 1X for a universal aluminum rod contact for aluminum or copper conductors.
- N5.** Use for insulation dia. range from 0.640" thru 1.070".
- N6.** Use for insulation dia. range from 0.830" thru 1.180".
- N7.** Fits overall cable O.D. from 0.750" to 1.625".

#### Terminations

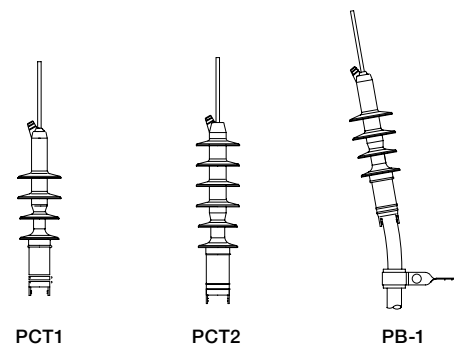

## Cable shield adapters and jacket seals

Elastimold® elbows, cable joints and terminators have been designed for use on XLP, EPR or similar solid dielectric insulated power cables. These cables are available with a variety of optional shielding and jacket constructions. In order to properly mate and install the cable to an Elastimold product, the use of a shield adapter, grounding kit

or jacket seal may be required. The diagram below provides information concerning the application and selection of various shield adapters, grounding kits and jacket seals for the most popular cable types. Consult your ABB representative for recommendations concerning other cable constructions.

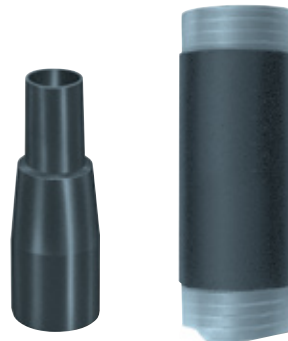
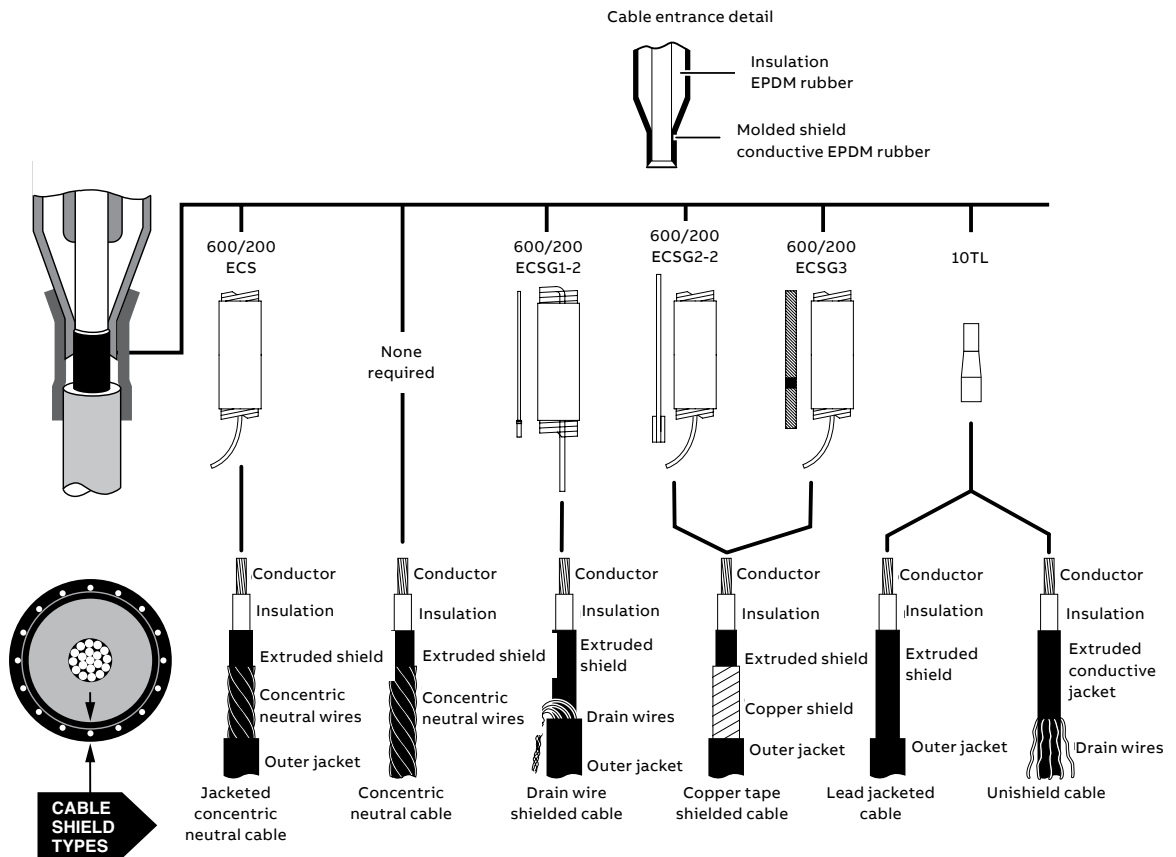



**Cable shield adapters**

Cable Insulation dia.	10TL inches
Min.	0.495
Max.	1.875

01 10TL



**Jacket seals**

Jacket O.D.	200ECS inches	600ECS inches
Min.	0.80	1.28
Max.	1.50	2.30

02 ECS

**Cable shield adapters and jacket seals**

Image (not to scale)	Description	Cat. no.	Suffix	Notes
	Cold-shrinkable jacket seal	200ECS	-S	N1, 3
	Cold-shrinkable jacket seal	600ECS	-S	N1, 4
	Shield adapter	10TL-W	-TL	N1, 2
	Cold-shrinkable seal with copper rod and crimp connector	200ECSG1-2	-SG1	N1, 3, 5, 6
	Cold-shrinkable seal with copper rod and crimp connector	600ECSG1-2	-SG1	N1, 4, 5, 6
	Cold-shrinkable seal with copper rod and constant force spring	200ECSG2-2	-SG2	N1, 3, 5, 6
	Cold-shrinkable seal with copper rod and constant force spring	600ECSG2-2	-SG2	N1, 4, 5, 6
	Cold-shrinkable seal with copper braid and constant force spring	200ECSG3	-SG3	N1, 3, 5, 7
	Cold-shrinkable seal with copper braid and constant force spring	600ECSG3	-SG3	N1, 4, 5, 7

**10TL insulation sizing**

Insulation inches		
Min.	Max.	Symbol For W
0.495	0.585	EB
0.525	0.635	EF
0.575	0.585	FA
0.625	0.735	FAB
0.675	0.785	FB
0.725	0.835	FG
0.775	0.885	GA
0.825	0.935	GAB
0.875	0.985	GB
0.930	1.040	GH
0.980	1.115	HA
1.040	1.175	HAB
1.095	1.240	HB
1.160	1.305	HJ
1.220	1.375	JA
1.285	1.395	JAB
1.355	1.520	JB
1.485	1.595	KA
1.530	1.640	KAB
1.575	1.685	KB
1.755	1.875	PA

**N1.** To order the kits as separate items, use the catalog numbers shown in the table.

Example: To order a cold-shrinkable tube as a separate item, use catalog number 200ECS.

To order the kits as components of other items, add the suffix to the end of the catalog number. Example: To order a cold-shrinkable jacket seal as a component of an elbow kit, use catalog number 162LR-A5200-S.

**N2.** Only use this suffix with catalog numbers that designate a "W" housing size. Sizing the main component will also size the suffix adapter.

**N3.** Size range 0.80" to 1.50" jacket diameters. Maximum installed diameter is approximately 2".

**N4.** Size range 1.28" to 2.30" jacket diameters. Maximum installed diameter is approx. 2.75".

**N5.** Voltage rating equal to Elastimold product being used.

**N6.** Copper rod size is No. 6 for sizes FA thru HA and No. 2 for sizes HAB thru JB.











**N7.** Braid is equivalent to No. 6 copper rod for sizes FA thru HA and No. 2 copper rod for sizes HAB thru JB.

## Equipment bushings

The ABB Elastimold® brand offers a complete line of 200 A bushing well and 600 A series apparatus bushings for use on transformers, switchgear and other equipment applications. The bushings incorporate IEEE 386 standard interfaces (shown on 6) and are constructed of molded epoxy with stainless steel flanges for mounting by welding or

gasketed clamp. Bushings are available for use on air, oil or SF6 insulated equipment. Units are rated for submersible, padmount, indoor, outdoor and other applications. Options include hold-down bail tabs and replaceable studs for 200-amp deepwell bushings.

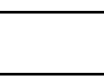
### Equipment bushings

Image (not to scale)	Description	Voltage class (kV)	Cat. no.	Bushing shank length (in.)	Notes
	Short shank well with bail tabs and non-replaceable well stud	15/25	K1601PC-S1	2 <sup>3</sup> / <sub>4</sub>	N3, 7, 12
		35	L1601PC-S1		N3, 7, 12, 16
	Short shank well with bail tabs and replaceable well stud	15/25	K1601PC-S1-R	2 <sup>3</sup> / <sub>4</sub>	N1, 3, 7, 12
		35	L1601PC-S1-R		N1, 3, 7, 12, 16
	Short shank well without bail tabs and non-replaceable well stud	15/25	K1601PC-S2	2 <sup>3</sup> / <sub>4</sub>	N3, 7, 12, 15
		35	L1601PC-S2		N3, 7, 12, 15, 16
	Short shank well without bail tabs and with replaceable well stud	15/25	K1601PC-S2-R	2 <sup>3</sup> / <sub>4</sub>	N1, 3, 7, 12, 15
		35	L1601PC-S2-R		N1, 3, 7, 12, 15, 16
	Long shank well with bail tabs and non-replaceable well stud	15/25	K1601PC-T1	9 <sup>1</sup> / <sub>4</sub>	N3, 7, 12
		35	L1601PC-T1		N3, 7, 12, 16
	Long shank well with bail tabs and with replaceable well stud	15/25	K1601PC-T1-R	9 <sup>1</sup> / <sub>4</sub>	N1, 3, 7, 12
		35	L1601PC-T1-R		N1, 3, 7, 12, 16
	Long shank well without bail tabs and with non-replaceable well stud	15/25	K1601PC-T2	9 <sup>1</sup> / <sub>4</sub>	N3, 7, 12, 15
		35	L1601PC-T2		N3, 7, 12, 15, 16
	Long shank well without bail tabs and with replaceable well stud	15/25	K1601PC-T2-R	9 <sup>1</sup> / <sub>4</sub>	N1, 3, 7, 12, 15
		35	L1601PC-T2-R		N1, 3, 7, 12, 15, 16
	200 A deadbreak bushing	15/25	K180S4	2 <sup>9</sup> / <sub>16</sub>	N3, 7, 11
	200 A deadbreak bushing	15/25	K180T4	7 <sup>11</sup> / <sub>32</sub>	N3, 7, 11
	200 A deadbreak bushing	15/25	K180C4	9 <sup>1</sup> / <sub>4</sub>	N3, 7, 11
	600 A short shank bushing without stud	15/25	K650S1	2 <sup>15</sup> / <sub>16</sub>	N2, 5, 7, 12, 13, 15, 18, 19
	900 A Cu short shank bushing without stud	15/25	K675S1		N3, 5, 7, 12, 13, 15, 18 19
	600 A short shank bushing without stud	35	750S1		N2, 5, 7, 12, 14, 15, 16, 18 19
	600 A long shank bushing without stud	15/25	K650T1	8 <sup>9</sup> / <sub>16</sub>	N2, 5, 7, 12, 13, 15, 18
	900 A Cu long shank bushing without stud	15/25	K675T1	8 <sup>9</sup> / <sub>16</sub>	N3, 5, 7, 12, 13, 15, 18
	600 A long shank bushing without stud	35	750T1	8 <sup>9</sup> / <sub>16</sub>	N2, 5, 7, 12, 14, 15, 16, 18
	600 A 12" long shank bushing without stud	35	750L12	12	N2, 5, 7, 12, 14, 15, 16, 18
	600 A in-air long shank bushing without stud	15/25	K650TBC	8 <sup>9</sup> / <sub>16</sub>	N2, 4, 7, 6, 12
	900 A Cu in-air long shank bush without stud	15/25	K675TBC	-	N3, 5, 7, 6, 12
	Boot and collars for K600T1 to use in air	15/25	600BC	-	N6
	600 A bushing and gasket kit	15/25	600CK	-	-
	35	600CK	-	-	
	200 A bushing clamp and gasket kit – 3 holes	15/25	K1601PC-S2-CK3H	-	17
		35	L1601PC-S2-CK3H	-	17
	200 A bushing clamp and gasket kit – 4 holes	15/25	K1601PC-S2-CK4H	-	17
		35	L1601PC-S2-CK4H	-	17

**N1.** Replacement stud available separately. Specify 1601RS.

**N2.** Equipped with standard aluminum conductor rod.

**N3.** Equipped with copper conductor rod.

**N4.** Includes 3/8"-11 threaded stud at elbow end.

**N5.** Includes 3/8"-11 threaded hole at elbow end.

**N6.** Provides increased creep and strike.

**N7.** Includes shipping cap.

**N11.** Parking stands for 200 A deadbreak applications are available as separate items. Specify 151PS.

**N12.** Parking stands for 200 A loadbreak and 600 A deadbreak applications are available as separate items. Specify 160PS.

**N13.** Aluminum stud available separately. Specify 650SA.

**N14.** Aluminum stud available separately. Specify 750SA.

**N15.** Available as a kit with clamp and gasket adding suffix "CK".

**N16.** Available for 35 kV with 200 kV BIL adding suffix "-200".

**N17.** For use on bushing well without bail tabs only.

**N18.** Add suffix "-CLB" for flange with stud clearance for clamping.

**N19.** Notched flange for bolted mounting add -NF

## Medium-voltage cable accessories technical information

### How to specify size-sensitive products

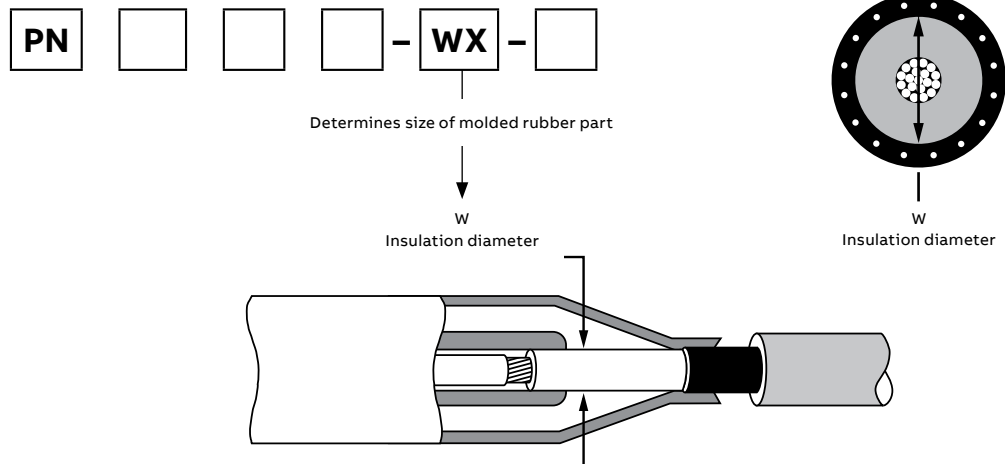

### Insulation diameter selection guide

Elastimold® elbows, cable joints and terminations are designed for application on XLP, EPR and other solid-dielectric insulated power cables. These components are constructed of molded elastomer and rely on an interference fit with the cable insulation diameter in order to maintain proper dielectric strength, creep path integrity and a water seal. Elastimold components are available in a wide range of sizes in order to accommodate a variety of cable insulation diameters.

Selection of size-sensitive components requires determining the cable insulation diameter. This can be done in several ways:

- A. Refer to the cable manufacturer's spec sheet for dimensions.
- B. Measure the cable.
- C. If the cable conforms to AEIC or ICEA standards and is:
  1. 15 kV, 175-mil wall thickness, use the table on 80.

2. 15 kV, 220-mil wall thickness, use the table on 81.
3. 25 kV, 260-mil wall thickness, use the table on 82.
4. 35 kV, 345-mil wall thickness, use the table on 82.

After the cable insulation diameter minimum and maximum have been determined:

1. Locate the W table indicated in the catalog number selection chart.
2. Complete the ordering information by selecting and inserting the symbol (given in the W table) into the catalog number.



## Medium-voltage cable accessories technical information

### Ordering examples

#### AEIC

To complete the information required to order a K655LR-W0X elbow for use on standard AEIC 1000 kcmil compressed stranding aluminum 25 kV cable with 0.260" thick insulation wall:

- A. Determine that the insulation diameter (for AEIC cable in the table on page 82) is 1.645 – 1.770".
- B. For this elbow, the catalog number selection chart on 21 indicates to use Table W7 for elbow sizing and Table X6 for connector sizing.
- C. From Table W7, the symbol for W is N.
- D. From Table X6, the symbol for X is 410.
- E. The completed catalog number, therefore, is K655LR-N0410.

#### ICEA

To complete the information required to order a K655LR-W0X elbow for use on standard ICEA 1000 kcmil compressed stranding aluminum 25 kV cable with 0.260" thick insulation wall:

- A. Determine that the insulation diameter (for ICEA cable in the table on page 82) is 1.645 – 1.740".
- B. For this elbow, the catalog number selection chart on 21 indicates to use Table W7 for elbow sizing and Table X6 for connector sizing.
- C. From Table W7, the symbol for W is N.
- D. From Table X6, the symbol for X is 410.
- E. The completed catalog number, therefore, is K655LR-N0410.

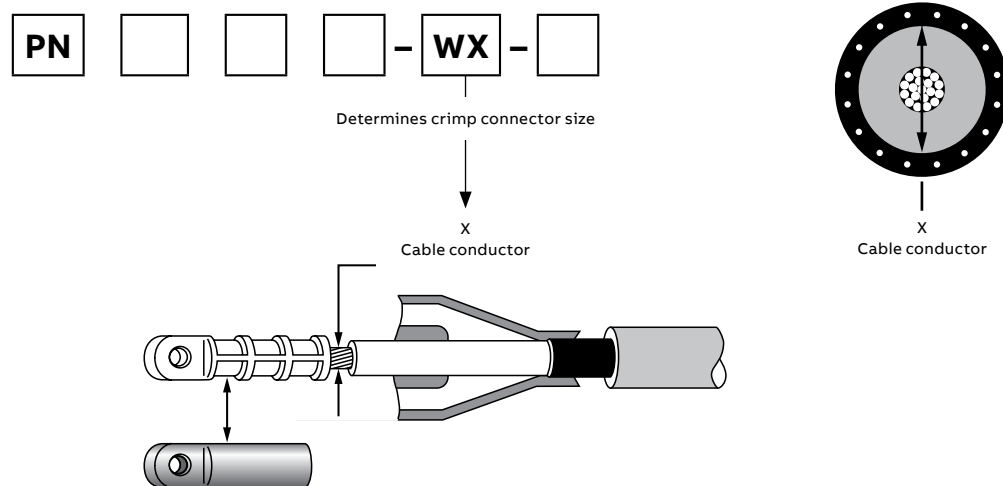

## Connector selection guide

Elastimold® elbows, cable joints and terminations are furnished with crimp-style cable connectors. As standard, these connectors are constructed with a tin-plated aluminum barrel filled with an oxide inhibitor. Most aluminum barrel connectors are universal and are designed for use on either aluminum or copper conductor cable.

When specified, all copper crimp-style connectors can be furnished. These connectors are only for use on copper conductor cable and are not for use with aluminum conductor cables. Bi-metallic connectors are constructed with a copper top and an aluminum barrel. Bi-metal connectors can be used on either aluminum or copper conductor cable and are furnished as standard with 200 A loadbreak elbows and 200 A deadbreak elbows. PCT and R2T terminators are furnished with rod connectors.

### Aluminum connectors used in PCJ cable joints are rated as follows:

- Aluminum conductor to aluminum conductor, cable rated
- Aluminum conductor to copper conductor, cable rated equal to the aluminum cable

### Copper connectors used in PCJ cable joints are rated as follows:

- Copper conductor to copper conductor, cable rated

Selecting and ordering the proper crimp connector requires determining information relative to the cable conductor as follows:

- Conductor size in AWG or kcmil
- Conductor type (stranded, compressed, compact or solid)
- Conductor material (aluminum or copper)

After the cable conductor information has been determined:

1. Locate the X table indicated in the catalog number selection chart.
2. Complete the ordering information by selecting and inserting the symbol (given in the X table) into the catalog number.

See the ordering examples on page 78 for further information.

## Medium-voltage cable accessories technical information

### AEIC and ICEA cable insulation diameter

#### AEIC CS8-06

Specification for extruded dielectric, shielded power cable rated 5–46 kV

AEIC-calculated diameters – Solid and compressed stranding from tables C-4 and C-6 and compact stranding from tables C-5 and C-7

#### ANSI/ICEA S-94-649-2004 & S-97-682-2000

Standard for concentric neutral cables and utility shielded power cables rated 5–46 kV

ICEA – Concentric stranding from table C-3, compressed stranding from table C-4, compact stranding from table C-5

ICEA abbreviated – For additional cables, please refer to the standard

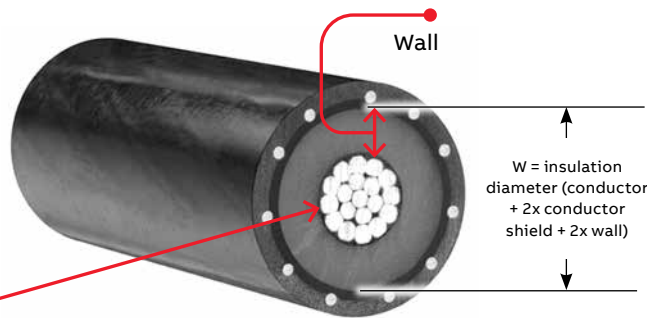

- 15 kV 100% – 175 mil insulation (0.175")
- 15 kV 133% – 220 mil insulation (0.220")
- 25 kV 100% – 260 mil insulation (0.260")
- 35 kV 100% – 345 mil insulation (0.345")

15 kV cable (100% level, 175 mil)

Aluminum and copper conductor size (AWG or kcmil)	Industry standard	Solid conductor		Stranded conductor		Compressed conductor		Compact conductor	
		Diameter in inches over insulation		Diameter in inches over insulation		Diameter in inches over insulation		Diameter in inches over insulation	
		Min.	Max.	Min.	Max.	Min.	Max.	Min.	Max.
#2	AEIC	0.610	0.700	–	–	0.635	0.725	0.620	0.710
	ICEA	0.610	0.695	0.645	0.730	0.635	0.720	0.620	0.705
#1	AEIC	0.645	0.730	–	–	0.675	0.765	0.655	0.740
	ICEA	0.645	0.725	0.685	0.770	0.675	0.760	0.655	0.735
1/0	AEIC	0.680	0.770	–	–	0.715	0.805	0.690	0.775
	ICEA	0.680	0.760	0.725	0.810	0.715	0.800	0.690	0.775
2/0	AEIC	–	–	–	–	0.760	0.850	0.730	0.815
	ICEA	–	–	0.775	0.855	0.760	0.845	0.730	0.815
3/0	AEIC	–	–	–	–	0.810	0.900	0.775	0.865
	ICEA	–	–	0.825	0.905	0.810	0.895	0.775	0.860
4/0	AEIC	–	–	–	–	0.865	0.955	0.830	0.915
	ICEA	–	–	0.880	0.965	0.865	0.950	0.830	0.910
250	AEIC	–	–	–	–	–	–	–	–
	ICEA	–	–	0.935	1.020	0.920	1.005	0.880	0.965
350	AEIC	–	–	–	–	1.025	1.115	0.980	1.065
	ICEA	–	–	1.045	1.130	1.025	1.110	0.980	1.065
500	AEIC	–	–	–	–	1.150	1.245	1.100	1.185
	ICEA	–	–	1.175	1.260	1.150	1.235	1.100	1.185
750	AEIC	–	–	–	–	1.340	1.440	1.280	1.370
	ICEA	–	–	1.370	1.455	1.340	1.425	1.280	1.365
1000	AEIC	–	–	–	–	1.485	1.590	1.430	1.520
	ICEA	–	–	1.520	1.610	1.485	1.575	1.430	1.515

ICEA Note: Diameters specified in the above table are different than specified by AEIC CS8-00. Consult accessory manufacturer for proper selection of accessories. Diameters to be measured in accordance with 9.6.

## Medium-voltage cable accessories technical information

### AEIC and ICEA cable insulation diameter

15 kV cable (133% level, 220 mil)

Aluminum and copper conductor size (AWG or kcmil)	Industry standard	Solid conductor		Stranded conductor		Compressed conductor		Compact conductor	
		Diameter in inches over insulation		Diameter in inches over insulation		Diameter in inches over insulation		Diameter in inches over insulation	
		Min.	Max.	Min.	Max.	Min.	Max.	Min.	Max.
#2	AEIC	0.700	0.790	-	-	0.725	0.815	0.710	0.800
	ICEA	0.700	0.790	0.735	0.825	0.725	0.815	0.710	0.800
#1	AEIC	0.735	0.820	-	-	0.765	0.855	0.745	0.830
	ICEA	0.735	0.820	0.775	0.865	0.765	0.855	0.745	0.830
1/0	AEIC	0.770	0.860	-	-	0.805	0.895	0.780	0.865
	ICEA	0.770	0.855	0.815	0.905	0.805	0.895	0.780	0.865
2/0	AEIC	-	-	-	-	0.850	0.940	0.820	0.905
	ICEA	-	-	0.865	0.950	0.850	0.935	0.820	0.905
3/0	AEIC	-	-	-	-	0.900	0.990	0.865	0.955
	ICEA	-	-	0.915	1.000	0.900	0.985	0.865	0.955
4/0	AEIC	-	-	-	-	0.955	1.045	0.920	1.005
	ICEA	-	-	0.970	1.060	0.955	1.045	0.920	1.005
250	AEIC	-	-	-	-	-	-	-	-
	ICEA	-	-	1.025	1.115	1.010	1.100	0.970	1.060
350	AEIC	-	-	-	-	1.115	1.205	1.070	1.155
	ICEA	-	-	1.135	1.220	1.115	1.200	1.070	1.155
500	AEIC	-	-	-	-	1.240	1.335	1.190	1.275
	ICEA	-	-	1.265	1.355	1.240	1.330	1.190	1.275
750	AEIC	-	-	-	-	1.430	1.530	1.370	1.460
	ICEA	-	-	1.460	1.550	1.430	1.520	1.370	1.460
1000	AEIC	-	-	-	-	1.575	1.680	1.520	1.610
	ICEA	-	-	1.610	1.705	1.575	1.670	1.520	1.610

## Medium-voltage cable accessories technical information

### AEIC and ICEA cable insulation diameter

#### 25 kV cable (100% Level, 260 mil)

Aluminum and copper conductor size (AWG or kcmil)	Industry standard	Solid conductor		Stranded conductor		Compressed conductor		Compact conductor	
		Diameter in inches over insulation		Diameter in inches over insulation		Diameter in inches over insulation		Diameter in inches over insulation	
		Min.	Max.	Min.	Max.	Min.	Max.	Min.	Max.
#1	AEIC	0.805	0.900	–	–	0.835	0.935	0.815	0.910
	ICEA	0.805	0.895	0.845	0.935	0.835	0.925	0.815	0.905
1/0	AEIC	0.840	0.940	–	–	0.875	0.975	0.850	0.945
	ICEA	0.840	0.930	0.885	0.980	0.875	0.965	0.850	0.940
2/0	AEIC	–	–	–	–	0.920	1.020	0.890	0.985
	ICEA	–	–	0.935	1.025	0.920	1.010	0.890	0.980
3/0	AEIC	–	–	–	–	0.970	1.070	0.935	1.035
	ICEA	–	–	0.985	1.075	0.970	1.060	0.935	1.030
4/0	AEIC	–	–	–	–	1.025	1.125	0.990	1.085
	ICEA	–	–	1.040	1.135	1.025	1.115	0.990	1.080
250	AEIC	–	–	–	–	–	–	–	–
	ICEA	–	–	1.095	1.190	1.080	1.175	1.040	1.135
350	AEIC	–	–	–	–	1.185	1.295	1.140	1.245
	ICEA	–	–	1.205	1.295	1.185	1.275	1.140	1.230
500	AEIC	–	–	–	–	1.310	1.425	1.260	1.365
	ICEA	–	–	1.335	1.430	1.310	1.405	1.260	1.350
750	AEIC	–	–	–	–	1.500	1.620	1.440	1.550
	ICEA	–	–	1.530	1.625	1.500	1.595	1.440	1.535
1000	AEIC	–	–	–	–	1.645	1.770	1.590	1.700
	ICEA	–	–	1.680	1.775	1.645	1.740	1.590	1.685

#### 35 kV cable (100% level, 345 mil)

Aluminum and copper conductor size (AWG or kcmil)	Industry standard	Solid conductor		Stranded conductor		Compressed conductor		Compact conductor	
		Diameter in inches over insulation		Diameter in inches over insulation		Diameter in inches over insulation		Diameter in inches over insulation	
		Min.	Max.	Min.	Max.	Min.	Max.	Min.	Max.
1/0	AEIC	1.010	1.110	–	–	1.045	1.145	1.020	1.115
	ICEA	1.010	1.110	1.055	1.155	1.045	1.145	1.020	1.120
2/0	AEIC	–	–	–	–	1.090	1.190	1.060	1.155
	ICEA	–	–	1.105	1.200	1.090	1.190	1.060	1.160
3/0	AEIC	–	–	–	–	1.140	1.240	1.105	1.205
	ICEA	–	–	1.155	1.255	1.140	1.240	1.105	1.205
4/0	AEIC	–	–	–	–	1.195	1.295	1.160	1.255
	ICEA	–	–	1.210	1.310	1.195	1.295	1.160	1.260
250	AEIC	–	–	–	–	–	–	–	–
	ICEA	–	–	1.265	1.370	1.250	1.350	1.210	1.315
350	AEIC	–	–	–	–	1.355	1.470	1.310	1.420
	ICEA	–	–	1.375	1.475	1.355	1.455	1.310	1.410
500	AEIC	–	–	–	–	1.480	1.600	1.430	1.540
	ICEA	–	–	1.505	1.605	1.480	1.580	1.430	1.530
750	AEIC	–	–	–	–	1.670	1.795	1.610	1.725
	ICEA	–	–	1.700	1.800	1.670	1.770	1.610	1.710
1000	AEIC	–	–	–	–	1.815	1.945	1.760	1.875
	ICEA	–	–	1.850	1.955	1.815	1.920	1.760	1.865

ICEA Note: Diameters specified in the above table are different than specified by AEIC CS8-00. Consult accessory manufacturer for proper selection of accessories. Diameters to be measured in accordance with 9.6.

## Conductor diameters for copper and aluminum (Class B) stranded, compressed, compact and solid cables

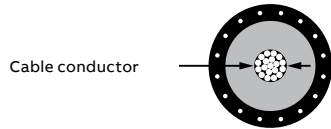

Conductor diameters for copper and aluminum (Class B) stranded, compressed, compact and solid cables

Conductor size (AWG or kcmil)	No. of strands and their nom. strand dia. (in.)	Cross-sectional area		Stranded conductors (inches)	Compressed conductors (inches)	Compact conductors (inches)	Solid conductors (inches)
		Square inches	mm <sup>2</sup> conversion				
#14	7 x 0.0242	0.0032	2.08	0.073	–	–	0.064
#12	7 x 0.0305	0.0051	3.31	0.092	–	–	0.081
#10	7 x 0.0385	0.0082	5.26	0.116	–	–	0.102
#8	7 x 0.0486	0.0130	8.37	0.146	–	–	0.129
#6	7 x 0.0612	0.0206	13.30	0.184	–	–	0.162
#4	7 x 0.0772	0.0328	21.15	0.232	–	–	0.204
#2	7 x 0.0974	0.0521	33.62	0.292	0.283	0.268	0.258
#1	19 x 0.0664	0.0657	42.41	0.332	0.322	0.299	0.289
1/0	19 x 0.0745	0.0829	53.49	0.373	0.362	0.336	0.325
2/0	19 x 0.0837	0.1054	67.43	0.418	0.405	0.376	–
3/0	19 x 0.0940	0.1318	85.01	0.470	0.456	0.423	–
4/0	19 x 0.1055	0.1662	107.2	0.528	0.512	0.475	–
250	37 x 0.0822	0.1964	127	0.575	0.558	0.520	–
350	37 x 0.0973	0.2749	177	0.681	0.661	0.616	–
500	37 x 0.1162	0.3924	253	0.813	0.789	0.736	–
600	61 x 0.0992	0.4712	304	0.893	0.866	0.813	–
700	61 x 0.1071	0.5498	355	0.964	0.935	0.877	–
750	61 x 0.1109	0.5890	380	0.998	0.968	0.908	–
800	61 x 0.1145	0.6283	405	1.031	1.000	0.938	–
900	61 x 0.1215	0.7069	456	1.094	1.061	0.999	–
1000	61 x 0.1280	0.7854	507	1.152	1.117	1.060	–
1100	91 x 0.1099	0.8639	557	1.209	1.173	–	–
1200	91 x 0.1148	0.9425	608	1.263	1.225	–	–
1250	91 x 0.1172	0.9818	633	1.289	1.250	–	–
1300	91 x 0.1195	1.021	659	1.315	1.276	–	–
1400	91 x 0.1240	1.100	709	1.364	1.323	–	–
1500	91 x 0.1284	1.178	760	1.412	1.370	–	–
1600	127 x 0.1122	1.257	811	1.459	1.415	–	–
1700	127 x 0.1157	1.335	861	1.504	1.459	–	–
1750	127 x 0.1174	1.374	887	1.526	1.480	–	–
1800	127 x 0.1191	1.414	912	1.548	1.502	–	–
1900	127 x 0.1223	1.492	963	1.590	1.542	–	–
2000	127 x 0.1225	1.571	1010	1.632	1.583	–	–

## Medium-voltage cable accessories technical information

Table W

Table W

Applicable cat. no. use for following products	Cable insulation diameter in inches		Symbol for W	Applicable cat. no. use for following products	Cable insulation diameter in inches		Symbol for W
	Min.	Max.			Min.	Max.	
<b>Table W1</b>				<b>Table W7</b>			
151SP/SR	0.575	0.740	A	K656I/CY/CH	0.420	0.660	D
151LS/LY	0.635	0.905	B	K655/656LR	0.530	0.680	E
161DLR	0.805	1.060	C	K655/656SR	0.640	0.820	F
161/162LR	0.890	1.220	D	655/656LINK	0.760	0.950	G
161/162LRJS	1.090	1.310	E	K655/656LINK	0.850	1.050	H
161LR/161LRJS				655/656ETP	0.980	1.180	J
261LR/261LRJS				K655/656ETP	1.090	1.310	K
162LR/162LRJS				655/656RTP	1.180	1.465	L
261DLR				K655/656LRTP	1.280	1.430	LM
262LR/262LRJS				655/656BI-LINK	1.370	1.630	M
					1.550	1.780	N
					1.665	1.785	PA
					1.725	1.935	P
<b>Table W2</b>				<b>Table W8</b>			
273RLR	0.760	0.950	G	15PCJ-1	0.640	0.820	F
274RLR	0.850	1.050	H	15PCJ-2	0.760	0.950	G
273DLR	0.980	1.180	J		0.850	1.050	H
	1.090	1.310	K		0.980	1.180	J
					1.090	1.310	K
					1.180	1.465	L
					1.280	1.430	LM
					1.370	1.630	M
					1.515	1.780	N
					1.725	1.935	P
					1.900	2.120	Q
<b>Table W3</b>				<b>Table W9</b>			
375LR	0.850	1.050	H	25PCJ-1	0.760	0.950	G
376LR	0.980	1.180	J	25PCJ-2	0.850	1.050	H
	1.090	1.310	K	755/756LR	0.980	1.180	J
	1.235	1.465	L	755/756LINK	1.090	1.310	K
				755/756ETP	1.180	1.465	L
				755/756LRTP	1.280	1.430	LM
				755/756BI-LINK	1.370	1.630	M
				755CA/CK/TCK	1.515	1.780	N
					1.725	1.935	P
					1.900	2.120	Q
					2.115	2.235	R
<b>Table W4</b>							
167/168RLR	0.640	0.820	F				
167LRT	0.760	0.950	G				
	0.850	1.050	H				
	0.980	1.180	J				
	1.090	1.310	K				
<b>Table W5</b>							
167/168ELR	0.665	0.895	6689				
273/274DEL	0.740	0.950	7495				
273/274ELR	0.880	1.100	88110				
167/168DEL	1.090	1.310	K				
<b>Table W6</b>							
10EP	0.495	0.585	EB				
152EA	0.525	0.635	EF				
160CA*	0.575	0.685	FA				
(*EB-FA only)	0.625	0.735	FAB				
	0.675	0.785	FB				
	0.725	0.835	FG				
	0.775	0.885	GA				
	0.825	0.935	GAB				
	0.875	0.985	GB				

## Medium-voltage cable accessories technical information

### Table W & Table X

Table W (continued)

Applicable cat. no. use for following products	Conductor size AWG or kcmil	Symbol for W		Applicable cat. no. use for following products	Conductor size AWG or kcmil	Symbol for W	
		Strand./ compr.	Compt./ solid.			Strand./ compr.	Compt./ solid.
<b>Table W10</b>				<b>Table W16</b>			
35PCJ-1	0.850	1.050	H	252LR	0.575	0.740	A
35PCJ-2	0.980	1.180	J	252LRJS	0.635	0.905	B
	1.090	1.310	K		0.805	1.060	C
	1.180	1.465	L		0.890	1.220	D
	1.370	1.630	M		1.090	1.310	E
	1.515	1.780	N				
	1.725	1.935	P				
	1.900	2.120	Q				

Table X

Applicable cat. no. use for following products	Conductor size AWG or kcmil	Symbol for X		Applicable cat. no. use for following products	Conductor size AWG or kcmil	Symbol for X	
		Strand./ compr.	Compt./ solid.			Strand./ compr.	Compt./ solid.
<b>Table X1</b>				<b>Table X6</b>			
167/168ELR/DELRL	#2	220	210	K655/656ETP	650	750/800	360
273/274ELR/DELRL	#1	230	220	755/756ETP	700/750	900	380
156LR, 161/162LR				655/656BI-LINK	800	-	390
261/262LR,167LRT	1/0	240	230	K655/656BI-LINK	900	1000	400
167/168RLR,167DLR	2/0	250	240	755BI-LINK	1000	-	410
273/274RLR,273DLR	3/0	260	250	655CK, 755CK	1000	-	410
00400, 02500, 02509, 02702,	4/0	270	260	655TCK, 03600	-	1250	420
02800, K151SP/SR,				03602, 03700, 03702	-	1250	440
375LR/376LR	250	-	270				
<b>Table X2</b>				<b>Table X7</b>			
375/376LR	1/0	240	230	15PCJ1	#2	220	210
375/376LR	2/0	250	240	25PCJ1	#1	230	220
	3/0	260	250	35PCJ1	1/0	240	230
	4/0	270	260	15PCJ2	2/0	250	240
<b>Table X6</b>				<b>Table X9</b>			
655/656LRTP	-	#2	210	PCT1	#2	220	210
K655/656LRTP	#2	#1	220	PCT2	#1	230	220
755/756LRTP	#1	1/0	230	01000	1/0	240	230
K656I/Y/H, K655/656LR	1/0	2/0	240	01010	2/0	250	240
755/756LR, K655/656SR	2/0	3/0	250		3/0	260	250
655/656LINK, K655/656LINK	3/0	4/0	260		4/0	270	260
755/756LINK, 655/656ETP	4/0	250	270				
K655/656ETP, 755/756ETP	250	300	280				
655/656BI-LINK	300	350	290				
K655/656BI-LINK	350	400	300				
755BI-LINK, 655CK	400	450	310				
755CK, 655TCK, 03600,	450	500/550	320				
03602, 03700, 03702	500	600	330				
K655/656LRTP	550	650	340				
755/756LRTP, K656I/Y/H	600	700	350				
K655/656LR, K655/656LR							
755/756LR, K655/656SR							
655/656LINK, K655/656LINK							
755/756LINK, 655/656ETP							
K655/656ETP, 755/756ETP							



# Elastimold fuse housings ordering information

The following diagram shows how to construct a catalog number for a fuse housing:

Indicates field that must be filled in to complete the catalog number.

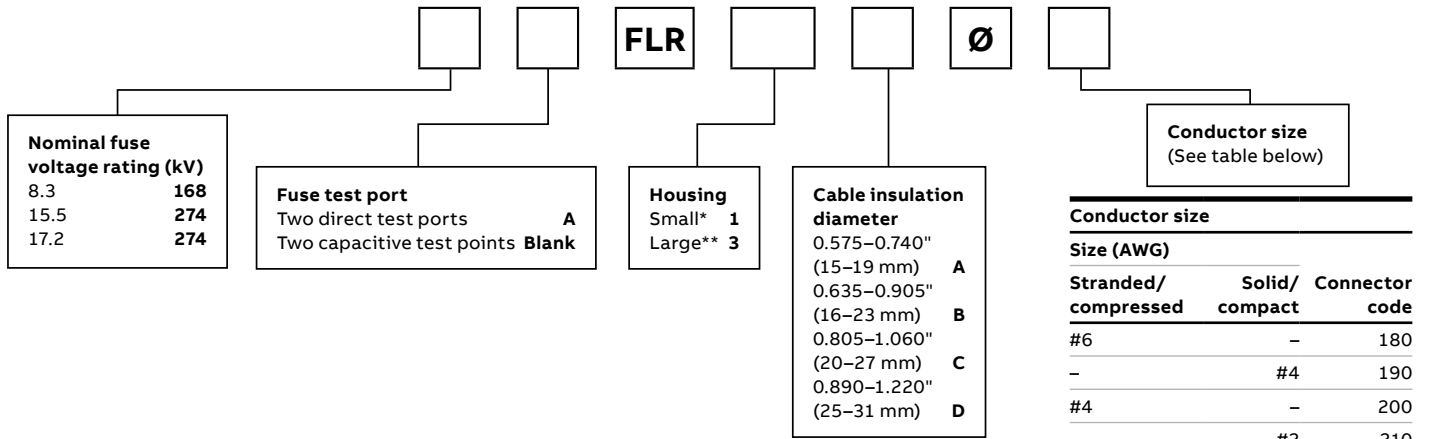

\*Small housing is used with 8.3 kV (3–45 A) and 15.5 kV (6–20 A) rated fuses.  
 \*\*Large housing is used with 8.3 kV (65 A and 80 A) and 17.2 kV (3–45 A) rated fuses.

- 01 168FLR1
- 02 274FLR1
- 03 168FLR3 A = 8 7/8" (225 mm)
- 274FLR3 A = 9 1/4" (235 mm)

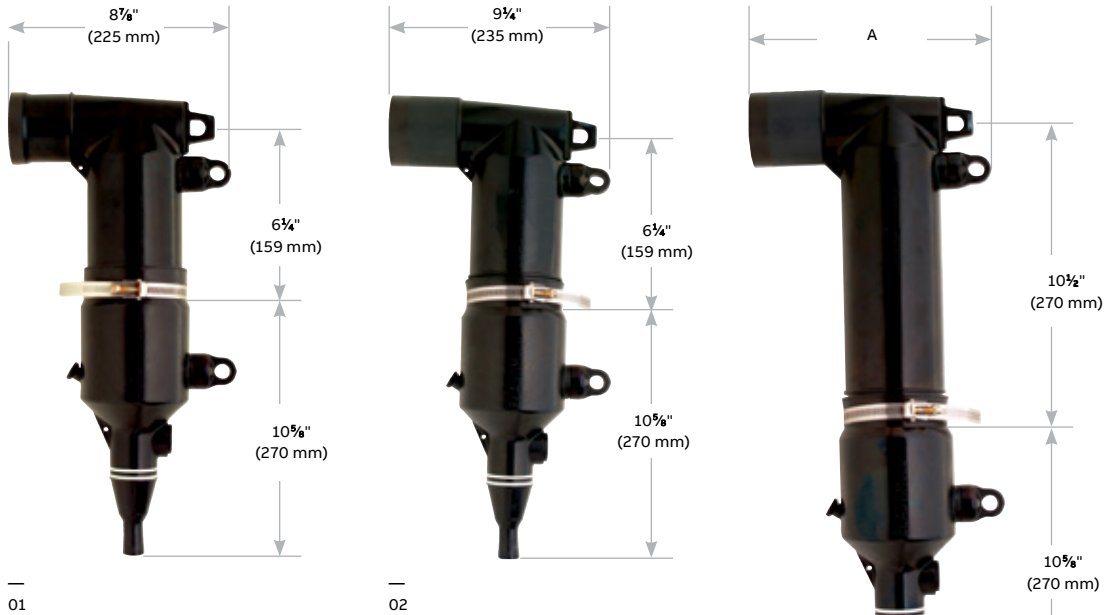

Note: 1. All dimensions rounded up to the nearest eighth inch.  
 2. Also available with direct test port.  
 3. Dimensions with direct test port units are 10 1/4" (260 mm) or 10 5/8" (270 mm).  
 4. 168FLR3 uses a large housing with a 15 kV, 200 A elbow interface.

## Current-limiting fuse ordering information

The following diagram shows how to construct a catalog number for full-range current-limiting fuses.

Indicates field that must be filled in to complete order.

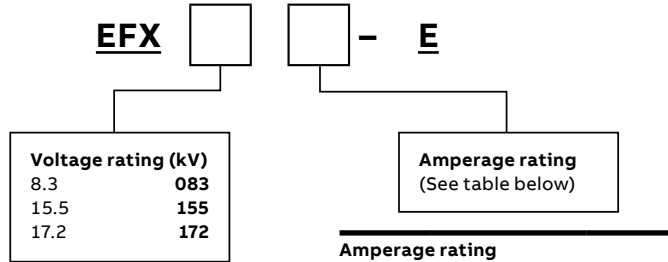

Amperage rating		
Amperage rating	kV	Code
3	8.3/17.2	003
6	8.3/15.5/17.2	006
8	8.3/15.5/17.2	008
10	8.3/15.5/17.2	010
12	8.3/15.5/17.2	012
18	8.3/15.5/17.2	018
20	8.3/15.5/17.2	020
25	8.3/17.2	025
30	8.3/17.2	030
40	8.3/17.2	040
45	8.3/17.2	045
65	8.3	065
80	8.3	080

—  
01 8.3 kV (3–45 A)/15.5 kV (6–20 A) fuse  
—  
02 8.3 kV (65–80 A)/17.2 kV (3–45 A) fuse

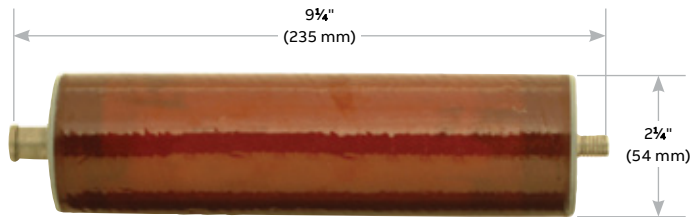

—  
01

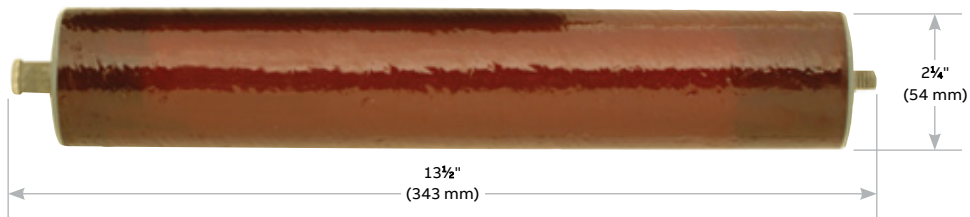

—  
02

Note: All dimensions rounded up to the nearest eighth inch.

## Shielded surge arresters

### Metal oxide varistor (MOV) surge arresters

Fully shielded, fully submersible for convenient energized connection with 200 A loadbreak or deadbreak components up to 35 kV.

- IEEE 386 interfaces provide convenient energized connection with other 200 A loadbreak or deadbreak components
- EPDM molded rubber construction – Fully shielded and fully submersible for a variety of applications
- Compact size enables installation in your existing cabinetry, saving you money
- Three styles of arresters available fit your application and are easy to install
- Direct connection on PSA and BSA versions eliminates the need for additional accessories, saving even more money
- #4 AWG ground lead tethered to the jacket withstands 10,000 A for 10 cycles without fusing
- Ground lead also controls end plug when ejected, preventing uncontrolled trajectory, and maintains the housing shield ground connection after failure

Voltage surges that exceed the BIL rating of the distribution system components will cause damage to the installed equipment. To protect against these surges, overhead surge arresters are widely used. Their application is understood since overhead lines and equipment are directly affected by voltage surges (e.g. lightning). However, the use of overhead arresters alone will not guarantee proper protection of the insulation in the underground portion of an electrical distribution system. The let-through surge from the riser pole arresters into the underground systems could be enough to cause damage to the aging equipment insulation.

Elastimold® MOV surge arresters provide high voltage lightning and switching surge protection of transformers, cable, equipment and other components typically located on underground power distribution systems. Proper placement, voltage selection and coordination with riser pole arresters minimize damaging surge voltages by improving protective margins.

Typical applications include installing an arrester at the end of a radial system or at both ends of an open point on a loop system. Additional arresters can be added at strategic locations upstream from the end point for optimum protection.

Metal oxide varistor (MOV) surge arresters are available in three styles: elbow (ESA™), parking stand (PSA™) and bushing (BSA™). The PSA and BSA arresters permit direct connection, eliminating the need for additional accessories. ESA elbow arresters are also available with a 200 A deadbreak interface for mating with other deadbreak accessories.

The following highlights the different installation options using bushing and parking stand arresters where elbow arresters are normally used. Using BSAs and PSAs will contribute to saving space inside transformers and improving operability.

#### Ratings

High current, short duration	All MOV arresters withstand two discharges of 40 kA crest
Low current, long duration	All MOV arresters withstand 20 surges of 75 A/2,000 microseconds duration
Duty cycle test	All MOV arresters withstand 22 operations of 5 kA crest at 8 x 20 microseconds duration while energized at rated voltage for the initial 20 operations and at maximum continuous operating voltage (MCOV) for the final two operations

Following each of the preceding tests, MOV arresters demonstrate thermal recovery at MCOV.

Installation options

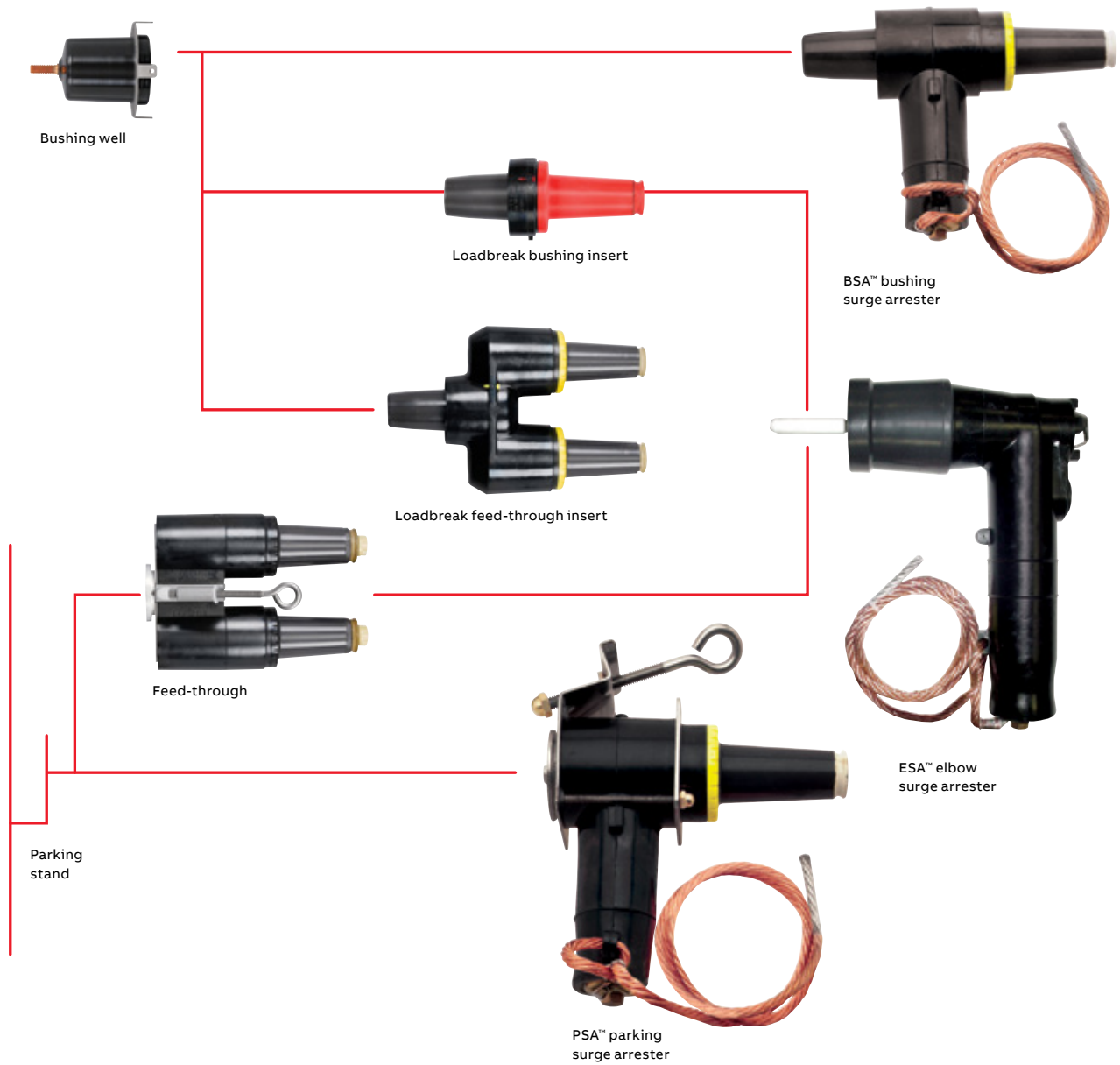

## Shielded surge arresters

Loop-feed circuit (type 2 transformer)



**Two elbow arresters and a feed-through**  
This approach uses elbow arresters only. (One of the elbow arresters may be mounted on the H1A bushing if operating procedures permit.)



**Elbow arrester and parking stand arrester**  
This approach can reduce overcrowding by eliminating the feed-through device. This is desirable in a mini-pad transformer.

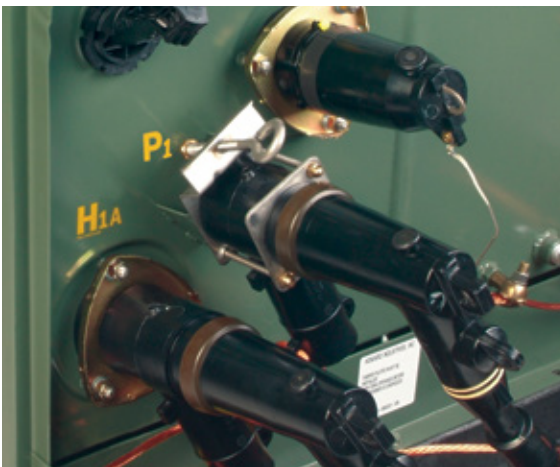

**Bushing arrester and parking stand arrester\***  
This approach is best for increasing operability and reducing transformer overcrowding.

The bushing arrester enables the source cable to be positioned on H1A, which conforms with some operating practices.

A bushing arrester mounted on H1A can be directed downward without interference. Potential interference between an elbow arrester on H1B and a cable parked on P is eliminated.

The bushing arrester requires significantly less space than an elbow arrester used with a feed-through insert.

Operability is enhanced because the open point can be closed by moving the parked cable to H1B without removing an arrester.

\* Transformers must be specified with bushing wells.

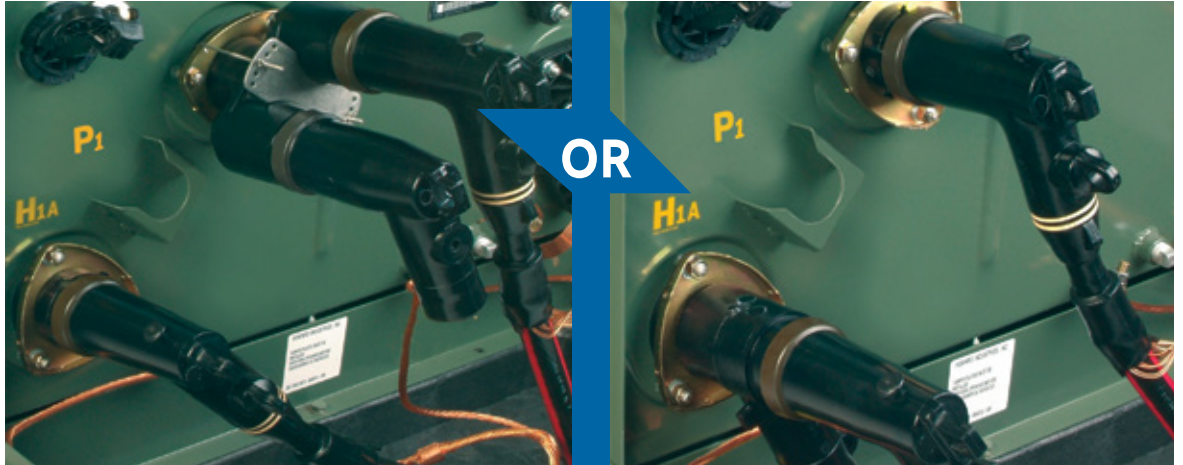

#### **Additional margin of protection**

An additional margin of protection may be gained by adding an arrester at the next transformer upstream on each side of the open point. This application is dependent on the system voltage and condition of the cable.

If an additional arrester is added in the circuit, it can be an elbow arrester in combination with a feed-through insert or it can be a bushing arrester. Use of a bushing arrester will reduce transformer faceplate overcrowding.

#### **Other configurations**

Other configurations are possible, such as specifying a bushing arrester on every transformer. This enables the open point to be quickly and easily moved to any point in the circuit while maintaining the surge protection (without moving all of the portable surge arresters).

The externally mounted bushing arrester provides the surge protection benefits without the negative factors of an under-oil arrester.



## Shielded surge arresters

Radial-feed circuit (end point)



### Single-bushing transformer

To add surge protection to a single-bushing transformer, use a bushing arrester or an elbow arrester with a feed-through insert.

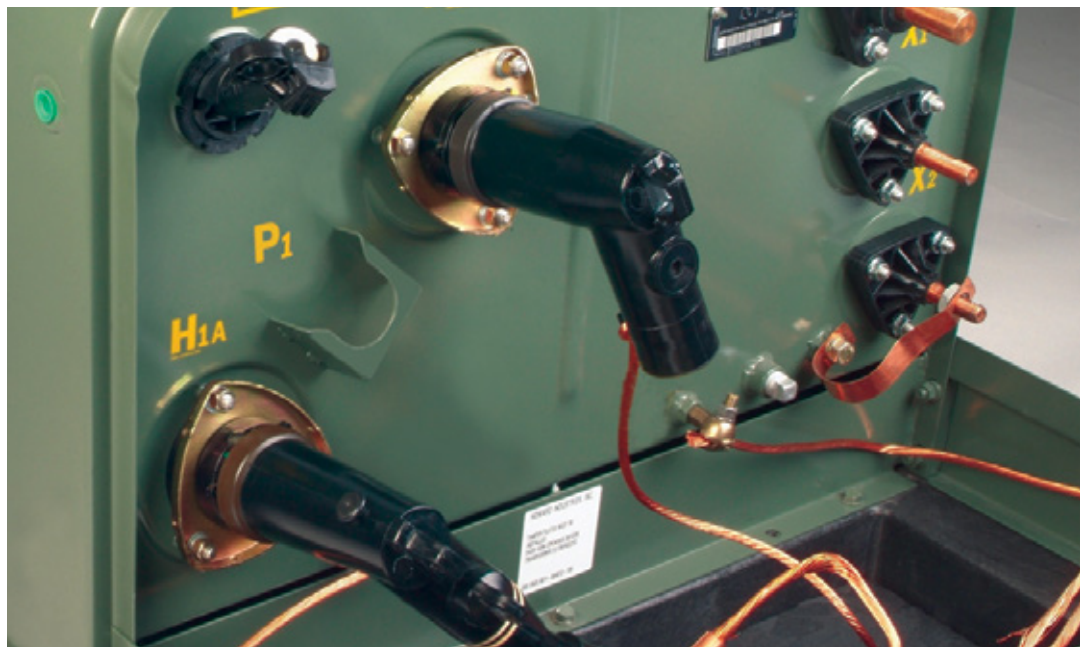

### Two-bushing transformer

To add surge protection to a two-bushing transformer at the end point of a radial-feed circuit, add an elbow arrester to the unoccupied bushing or use a bushing arrester.

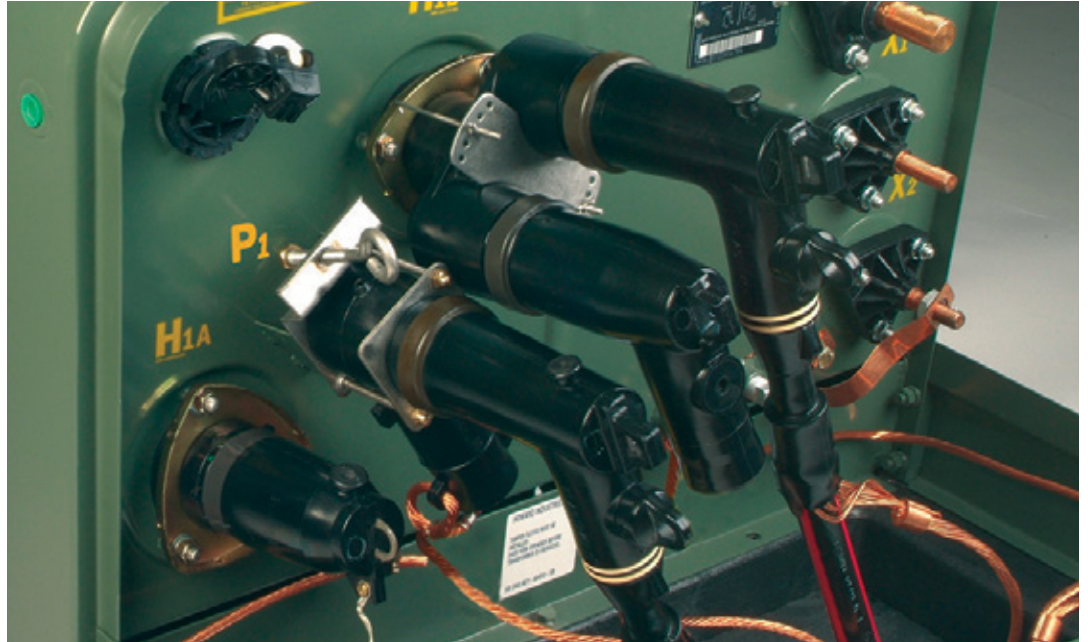

**Conversion of a radial-feed transformer to a loop-feed, open-point transformer**

To convert a single-bushing transformer to a loop-feed, open-point transformer, add a parking stand arrester and an elbow arrester in combination with a feed-through insert.

—  
**Protective characteristics**

Voltage class (kV)	MCOV (kV RMS)	Duty cycle rating (kV RMS)	Maximum discharge voltage (kV crest) 8 x 20 microsecond current wave				
			1.5 kA	3 kA	5 kA	10 kA	20 kA
15	2.55	3	8.06	8.48	8.74	9.36	10.4
	5.1	6	16.12	16.95	17.47	18.72	20.8
	8.4	10	28.21	29.66	30.57	32.76	36.4
	10.2	12	32.24	33.9	34.94	37.44	41.6
	12.7	15	40.3	42.38	43.68	46.8	52
	15.3	18	48.36	50.85	52.41	56.16	62.4
25	8.4	10	28.21	29.66	30.57	32.76	36.4
	10.2	12	32.24	33.9	34.94	37.44	41.6
	12.7	15	40.3	42.38	43.68	46.8	52
	15.3	18	48.36	50.85	52.41	56.16	62.4
	17	21	56.42	59.32	61.14	65.52	72.8
38	19.5	24	64.48	67.8	69.88	74.88	83.2
	22	27	72.54	76.28	78.62	84.24	93.6
	24.4	30	80.6	84.75	87.35	93.6	104
	29	36	96.72	101.7	104.82	112.32	124.8
	32.5	40.5	109.35	114.98	118.5	126.97	141.07



## Shielded surge arresters

To specify and order an MOV surge arrester:

1. Determine the appropriate maximum continuous operating voltage (MCOV) for your system voltage using the arrester application table below.
2. Specify the appropriate Elastimold® catalog number from the selection chart.

Arrester application table

Voltage class (kV)	System line-to-line voltage kV RMS		MCOV* kV RMS	
	Nominal	Maximum	Solidly grounded neutral circuits	3-Wire ungrounded circuits
15	2.40	2.54	2.55	2.55
	4.16	4.40	2.55	5.10
	4.80	5.08	5.10	5.10
	6.90	7.26	5.10	8.40
	8.32	8.80	5.10	8.40
	12.47	13.20	8.40	15.30
	13.20	13.97	8.40	15.30
	13.80	14.50	8.40**	15.30
	13.80	14.50	10.20	15.30
25	6.90	7.26	5.10	8.40
	8.32	8.80	5.10	8.40
	12.47	13.20	8.40	15.30
	13.20	13.97	8.40	15.30
	13.80	14.50	8.40**	15.30
	13.80	14.50	10.20	15.30
	20.78	22.00	12.70	–
	20.78	22.00	15.30**	–
	23.00	24.34	15.30	–
	24.94	26.40	15.30	–
	24.94	26.40	17.00**	–
28.00	29.80	17.00	–	

\* MCOV = maximum continuous operating voltage.

\*\* Preferred arrester MCOV for this system voltage.

—  
Selection chart

	Description	Voltage class (kV)	Cat. no.	MCOV kV RMS
	200 A BSA bushing surge arrester (includes assembly tool)  See notes 1-4	15	167BSA-3	2.55
			167BSA-6	5.10
			167BSA-10	8.40
			167BSA-12	10.20
			167BSA-15	12.70
		25	167BSA-18	15.30
			273BSA-10	8.40
			273BSA-12	10.20
			273BSA-15	12.70
			273BSA-18	15.30
	200 A ESA elbow surge arrester  See notes 1, 2, 5	15	167ESA-3	2.55
			167ESA-6	5.10
			167ESA-10	8.40
			167ESA-12	10.20
			167ESA-15	12.70
		25	167ESA-18	15.30
			273ESA-10	8.40
			273ESA-12	10.20
			273ESA-15	12.70
			273ESA-18	15.30
	200 A PSA parking stand arrester  See notes 1-3	15	167PSA-3	2.55
			167PSA-6	5.10
			167PSA-10	8.40
			167PSA-12	10.20
			167PSA-15	12.70
		25	167PSA-18	15.30
			273PSA-10	8.40
			273PSA-12	10.20
			273PSA-15	12.70
			273PSA-18	15.30
	600 A ESA elbow surge arrester	15/28	K655ESA-10	8.4
			K655ESA-12	10.2
			K655ESA-15	12.7
			K655ESA-18	15.3
			K655ESA-21	17.0

- Note: 1. Elastimold PSA and BSA arresters are equipped with a fully rated 200 A switching and fault-close loadbreak bushing.  
 2. Elastimold arresters use high strength, silver epoxy-bonded MOV blocks and shunted spring connections for the best circuit connection.  
 3. A 36" #4 AWG ground lead is provided with each unit.  
 4. BSA installed by turning internal hex bolt (accessed through the 200 A bushing interface) with a  $\frac{5}{16}$ " hex wrench and bent-wire torque wrench supplied with each unit.  
 5. For 15 kV and 25 kV class deadbreak system elbow arresters, use catalog number 156ESA with the appropriate duty cycle rating.

## Shielded surge arresters

To specify and order an MOV surge arrester:

1. Determine the appropriate maximum continuous operating voltage (MCOV) for your system voltage using the arrester application table below.
2. Specify the appropriate Elastimold® catalog number from the selection chart.

**Arrester application table**

Voltage class (kV)	System line-to-line voltage kV RMS		MCOV* kV RMS	
	Nominal	Maximum	Solidly grounded neutral circuits	3-Wire ungrounded circuits
35	23.00	24.34	–	22.00
	34.50	36.51	22.00**	–
	34.50	36.51	24.40	29.00

\* MCOV = maximum continuous operating voltage.

\*\* Preferred arrester MCOV for this system voltage.

—  
Selection chart

	Description	Voltage class (kV)	Cat. no.	MCOV kV RMS
	200 A BSA bushing surge arrester  See notes 1-4	35	375BSA-24	19.50
			375BSA-27	22.00
			375BSA-30	24.40
	200 A ESA elbow surge arrester  See notes 2-3	35	375ESA-24	19.50
			375ESA-27	22.00
			375ESA-30	24.40
			375ESA-36	29.00
	200 A PSA parking stand arrester  See notes 1-3	35	375PSA-24	19.50
			375PSA-27	22.00
			375PSA-30	24.40
	600 A ESA elbow surge arrester	35	755ESA-18	15.3
			755ESA-24	19.5
			755ESA-27	22.0
			755ESA-30	24.4
			755ESA-33	26.8
			755ESA-36	29.0
			755ESA-40.5	32.5

Note: 1. Elastimold PSA and BSA arresters are equipped with a fully rated 200 A switching and fault-close loadbreak bushing.

2. Elastimold arresters use high strength, silver epoxy-bonded MOV blocks and shunted spring connections for the best circuit connection.

3. A 36" #4 AWG ground lead is provided with each unit.

4. BSA installed by turning internal hex bolt (accessed through the 200 A bushing interface) with a  $\frac{5}{16}$ " hex wrench and bent-wire torque wrench supplied with each unit.

5. For 15 kV and 25 kV class deadbreak system elbow arresters, use catalog number 156ESA with the appropriate duty cycle rating.

## Transmission cable joints

TCJ™ transmission cable joints for 46 kV through 138 kV class systems

### Factory molded and tested to ensure the highest quality.

- Each cable joint is produced exactly per design, producing a quality not possible with field molding equipment or tape
- Electrically tested in the factory to ensure consistent quality
- Molding is done in the factory, reducing on-site time – No penciling of cable insulation required
- Easy-to-learn installation procedure
- Field molds, wrapping machines or pre-stretch not required, and a low-cost assembly tool is available
- Extended shelf life enables instant availability of spares
- Joints may be installed either as a standard shield break or as a non-shield break
- Designed with optimized pre-molded stress control and heat transfer capabilities

TCJ transmission cable joints for 46 kV through 138 kV class systems are designed by ABB, the manufacturer of Elastimold® pre-molded cable accessories.

All TCJ transmission cable joints are factory molded and factory tested, providing maximum reliability. Factory molding ensures a level of insulation and shielding system integrity not achievable with field-fabricated insulation systems. Use TCJ transmission cable joints in combination with various options for conductor connectors, shielding and environmental sealing, depending on the characteristics of the cable and your installation.

TCJ transmission cable joints are designed for use on solid dielectric cables with insulation diameters from 36.5 mm to 65.5 mm (1.43" to 2.58") for Style 1 (through 69 kV) and 57.2 mm to 91.96 mm (2.25" to 3.62") for Style 4 (through 138 kV). When assembled, they provide permanent, fully shielded, fully submersible cable joints for direct-burial or vault applications. A shield break option is provided for cross bonding purposes on Style 4.

Easy-to-learn installation procedures eliminate the need for labor-intensive field molds, tape-wrapping machinery or field expansion. Field assembly is greatly simplified, because all electrical stress-management elements have been provided during the factory-molding process rather than being fabricated in the field.

A TCJ transmission cable joint is available for your application. Contact your local ABB representative for a specific proposal based on your requirements.



TCJ™ construction

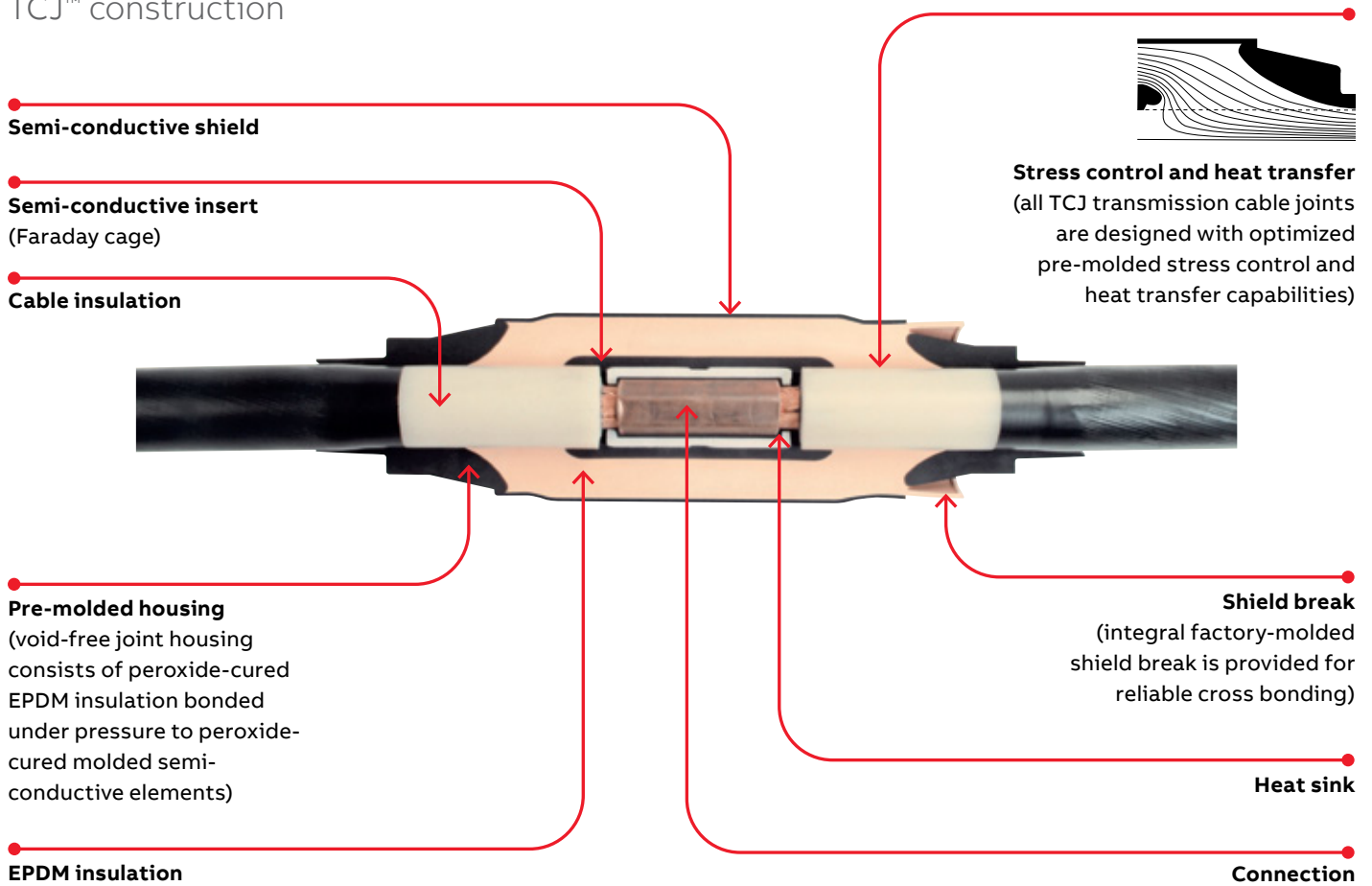

Dimensional information

Base cat. no.	Voltage class nominal (kV)	Maximum system voltage* (kV)	Style	Size	Inches				Millimeters			
					Insulation diameter range		Joint housing		Insulation diameter range		Joint housing	
					Min.	Max.	Diameter	Length	Min.	Max.	Diameter	Length
69TCJS1	69	72.5	1	M	1.435	1.675	4.16	20.35	36.5	45.6	105.7	516.9
					1.585	1.840	4.16	20.35	40.4	46.7	105.7	516.9
					1.790	2.090	4.75	22.48	45.5	53.1	120.7	571.0
					1.995	2.300	4.75	22.48	50.7	58.4	120.7	571.0
					2.200	2.580	4.75	22.48	55.9	65.5	120.7	571.0
69TCJS3	69	72.5	3	2	1.967	2.260	5.62	30.00	50.0	57.4	142.7	762.0
69TCJS4	69	72.5	4	3	2.252	2.607	7.22	32.00	57.2	66.2	183.4	812.8
					2.565	2.948	7.22	32.00	65.2	74.9	183.4	812.8
					2.900	3.290	7.22	32.00	73.7	83.6	183.4	812.8
					3.249	3.620	7.82	32.00	82.5	92.0	198.6	812.8
138TCJS3	138	145	3	2	1.967	2.260	5.62	30.00	50.0	57.4	142.7	762.0
138TCJS4	138	145	4	3	2.252	2.607	7.22	32.00	57.2	66.2	183.4	812.8
					2.565	2.948	7.22	32.00	65.2	74.9	183.4	812.8
					2.900	3.290	7.22	32.00	73.7	83.6	183.4	812.8
					3.249	3.620	7.82	32.00	82.5	92.0	198.6	812.8
					3.580	3.980	7.82	32.00	90.93	101.10	199.6	812.8

\* Maximum system voltage conforms with AEIC/IEC industry standards.

## Transmission cable joints

### Ratings for transmission cable joints

Nominal system voltage (kV)	69	138
Maximum system voltage: (kV)	72.5	145
BIL: 1.2 x 50µs; 10 pos., 10 neg., impulses (kV)	350	650
DC withstand: 15 min. (kV)	240	315
Minimum corona extinction voltage (kV) (3 pC sensitivity)	60	120
AC withstand: 15 min. (kV)	90	190
Current	Continuous rating equal to cable	
Thermal –	90 °C	
A. Max. continuous conduct. temp.	Class A/class 2	
B. Splice compression connectors per ANSI C119.4		
Semi-conductive shield	Meets shield test of IEEE 592	

### Type tests for transmission cable joints – per IEC 60840/IEEE 404

Tan delta @ 90 °C conductor	< 0.5%	< 0.5%
130 °C heating cycle voltage test (kV)	72	152
BIL: 1.2 x 50µs; 25 °C & 90 °C 10 pos., 10 neg., impulses (kV)	350	650
AC withstand: 6 hours (kV)	100	200

### Production tests for transmission cable joints (each unit)

Minimum corona extinction voltage (kV) (3 pC sensitivity)	60	120
AC withstand: (kV)	160/15 min.	240/30 min.

## Example of a typical installation of transmission cable joints

— 01 Overlap cables, straighten and strip back jacket.



— 01

— 02 Square cut the cable at the center line of the joint.

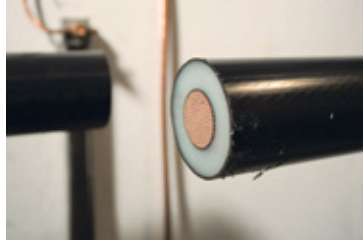

— 02

— 03 Remove the semi-conductive shield.



— 03

— 04 Bare the conductor.

— 05 Sand semi-conductive shield to provide a smooth transition to the cable insulation.



— 04



— 05

— 06 Store the cover-up sleeve on each cable.



— 06

— 07 Pull TCJ joint housing into the storage position on the cable.

— 08 Join the conductor using a compression, welded or other type of connector.



— 07



— 07

— 09 Conductors shown joined using a compression connector.

— 10 Reposition the assembly tool and pull the TCJ joint housing into the final position on the cable.



— 08

— 11 Seal joint ends with mastic wrap.

— 12 Connect neutral wires as required.

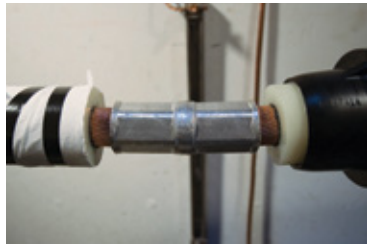

— 09



— 10

— 13 Position and shrink cover-ups.

— 14 Finished joint.



— 11



— 12



— 13



— 14

**Warning:** Refer to local code for required PPE.



## Transmission cable terminations

### Elastimold® 69TCT terminator

Class 1 termination for cable systems rated through 69 kV.



- Molded EPDM elastomer housing is durable under severe environmental conditions and does not require a surface oil/grease to maintain non-tracking properties
- State-of-the-art shed design employs unequal diameters to interrupt the drip path from shed to shed
- Housing slides over cable insulation to provide required creep path and waterseal
- Computer-designed molded stress relief ensures proper stress relief for the terminated cable

The 69TCT terminator provides a Class 1 termination for cable systems rated through 69 kV class. It conforms to IEC 840 and IEEE 48. This terminator is designed for solid dielectric cables with insulation diameters from 36.8 mm to 62.2 mm (1.45" x 2.45") and accommodates conductor sizes from 90 mm<sup>2</sup> to 1700mm<sup>2</sup> (4/0 to 3500 kcmil). Various aerial lugs are available for the conductor connection.

The durable elastomer construction eliminates glaze damage failures associated with porcelain. A state-of-the-art shed design ensures a non-continuous drip path, and the non-tracking polymer requires no surface oil or grease.

#### Installation

The 69TCT terminator is lightweight and easy to handle. It can be assembled horizontally on the ground and then raised to the installation position without a crane. Installation can be accomplished without special training using the Elastimold TCJ-ATK-U universal assembly tool. The 69TCT can use standard cable support systems.

#### Electrical data

Nominal voltage (kV)	69
Maximum working voltage (kV)	72.5
Partial discharge (kV)	<3 pC @ 60
BIL (@ 1.2 x 50 microsecond wave) 10 positive, 10 negative (kV)	350
AC withstand 60 Hz 1 minute dry (kV)	175

# TCT construction

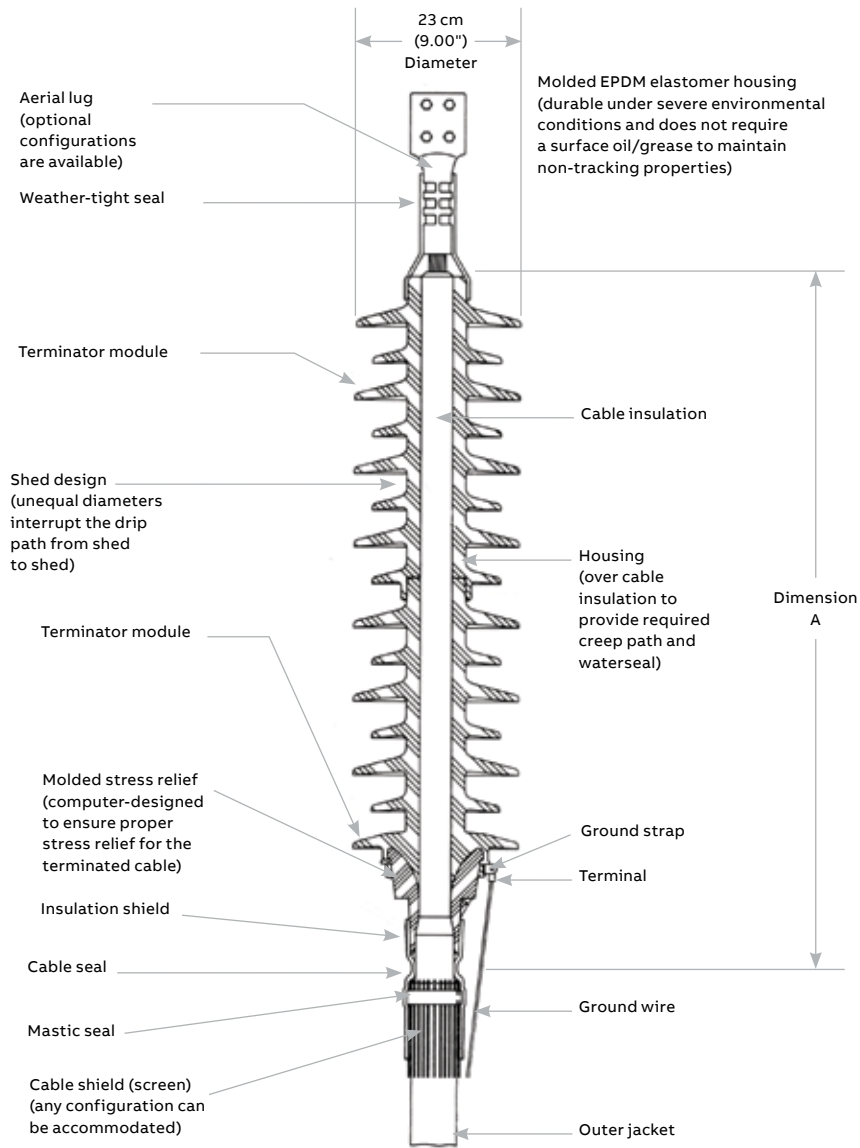

## Dimensional information

Base cat. no.	Voltage class nominal (kV)	Maximum system voltage* (kV)	Modules	Size	Inches						Millimeters					
					Insulation range		Termination height (A)	Strike distance	Creep distance	Insulation range		Termination height (A)	Strike distance	Creep distance		
					Min.	Max.				Min.	Max.					
69TCT	69	72.5	2	0	1.450	1.700	36.81	32.00	92.25	36.8	43.2	935.0	812.8	2343.2		
				1	1.650	1.900									41.9	48.3
				2	1.850	2.150									47.0	54.6
				3	2.100	2.450									53.3	62.2
69TCT	69	72.5	3	0	1.450	1.700	53.19	48.38	139.63	36.8	43.2	1351.0	1228.7	3546.5		
				1	1.650	1.900									41.9	48.3
				2	1.850	2.150									47.0	54.6
				3	2.100	2.450									53.3	62.2

\* Maximum system voltage conforms with AEIC/IEC industry standards.

## Transmission cable accessories installation tools

### Termination and joint installation tool – TCJ-ATK-U



Aids in sliding the joint or termination onto the cable.

#### TCJ installation

When installing a TCJ transmission cable joint, secure the cable clamp to the cable, position the housing clamp on the joint housing and then pull and park the joint on the cable by rotating the winch handles. Connect the conductors of the two cables and reverse the TCJ-ATK-U to slide the joint housing to the center of the splice.

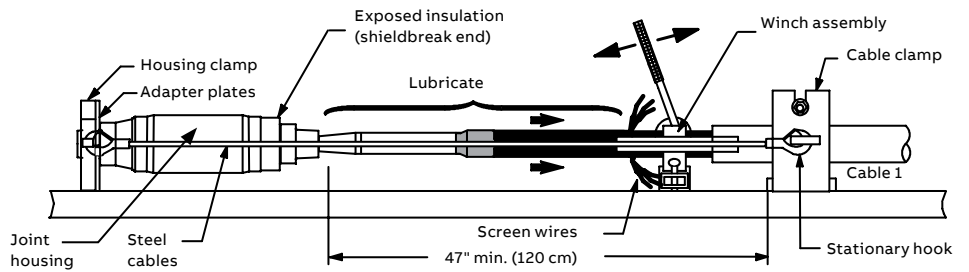

Typical transmission cable joint (TCJ) installation using the TCJ-ATK-U.



#### TCT installation

When installing a TCT transmission cable termination, secure the cable clamp to the cable, position the housing clamp on the termination housing and pull the termination into the cable by rotating the winch handles.

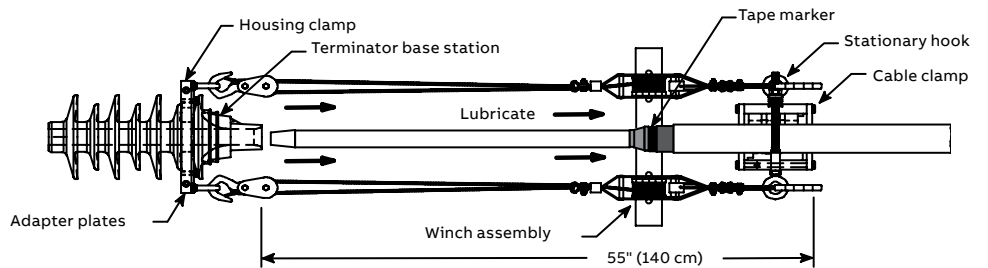

Typical transmission cable termination (TCT) installation using the TCJ-ATK-U.

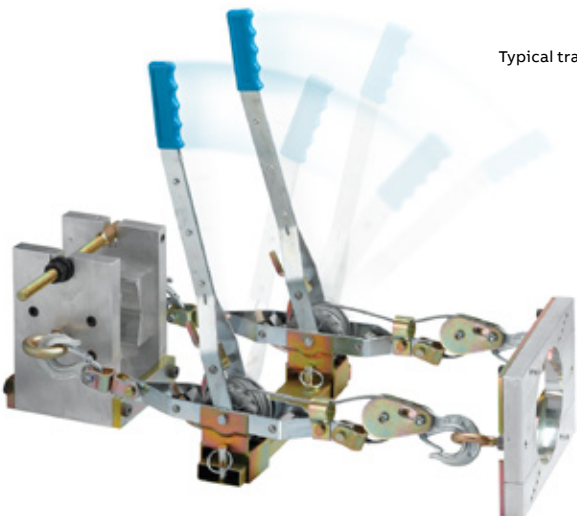

# Transmission cable accessories technical information

## Cable construction

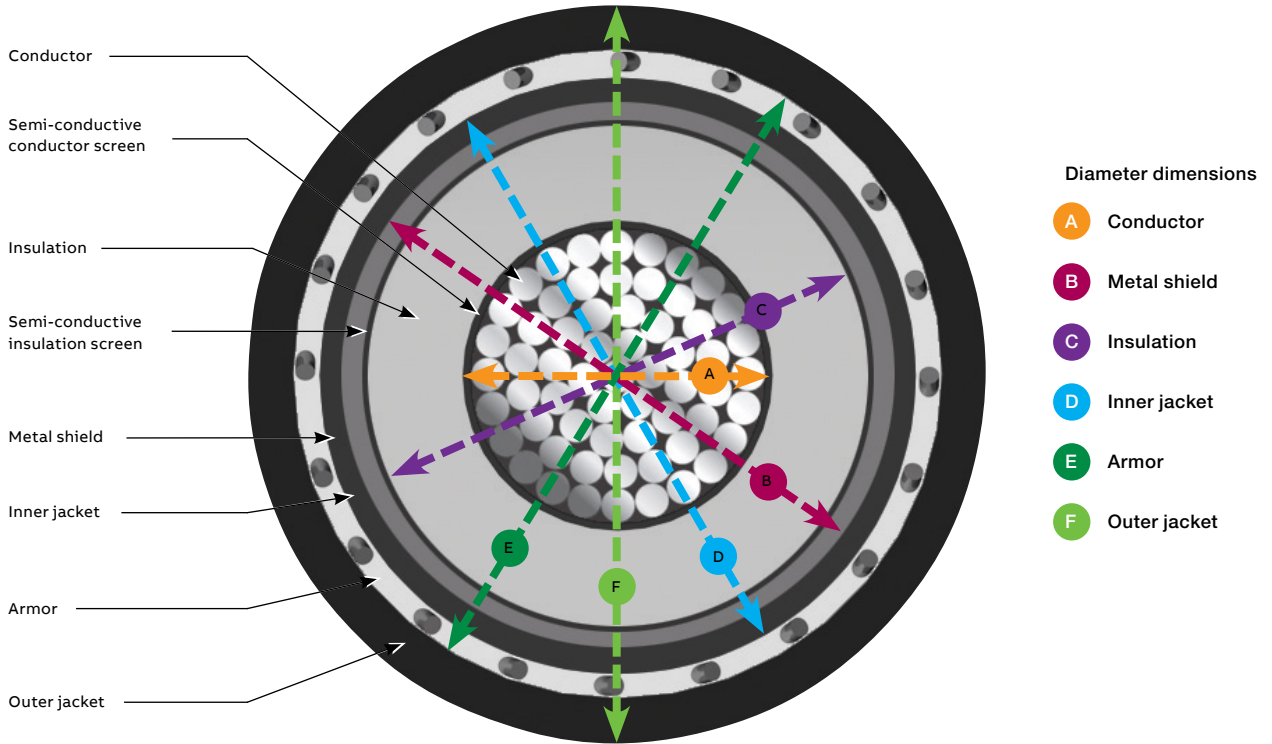

Provide cable cut sheet or provide dimensional data below.

### Cable data requirements for cable joint and cable termination selection

Item name	Material	Size (mm <sup>2</sup> or kcmil)	Outside diameter (mm or inches)
Conductor	<input type="checkbox"/> Aluminum <input type="checkbox"/> Copper		<b>A</b>
Metal shield			<b>B</b>

Item name	Material	Normal thickness (mm or inches)	Nominal outside diameter (mm or inches)
Insulation	<input type="checkbox"/> XLPE <input type="checkbox"/> EPR		<b>C</b>
Inner jacket			<b>D</b>
Armor*			<b>E</b>
Outer jacket*			<b>F</b>

\* If applicable

Nominal system voltage \_\_\_\_\_ kV

Non-shieldbreak joint qty. \_\_\_\_\_

Termination qty. \_\_\_\_\_

## Appendix

### Part number index

Cat. no.	Page	Cat. no.	Page	Cat. no.	Page
00400X	12	1602A3R	11	168RLR-W5X	10
00700X	73	160CA-W	12, 17	200AT	11
01000X	73	160DR	11	200ECS	75
01100X	73	160DRG	11	200ECSG1-2	75
02500X	12, 17	160GLR	11, 30, 34	200ECSG2-2	75
02509X	12	161DLR-W5X	10	200ECSG3	75
02702X	12, 17	161GP	11	200TC-1	12, 22
02800X	12	161LRJS-W5X	10	200TC-2	12, 22
03600X	34	161LR-W5X	10	200TC-4	12, 22
03602X	34	161SOP	11	252LRJS-W5X	16
03700X	22, 30, 34, 52	162LRJS-W5X	10	252LR-W0X	16
03702X	22, 30, 34, 52	162LR-W5X	10	25PCJ1GX	65
04601X	30	164FT	11	261DLR-W5X	10
04601XXX	22	164FT2-AB	11	261LRJS-W5X	10
10EP-W	12, 17	164FT3-AB	11	261LR-W5X	10
10TL-W	75	164FT4-AB	11	262LRJS-W5X	10
138TCJS3	99	164FTV	11	262LR-W5X	10
138TCJS4	99	164J2	12	2701A4	11
15/25/35PCJ1HX	65	164J2-5	12	2701EA4	11
15/25/35PCJ1JX	65	164J3	12	2702A1	11
15/25/35PCJ1KX	65	164J3-5	12	272GP	11
15/25/35PCJ1LX	65	164J4	12	272SOP	11
15/25/35PCJ1MX	65	164J4-5	12	273BSA-10	95
15/25/35PCJ1NX	65	164SOP	11	273BSA-12	95
15/25/35PCJ1PX	65	166LRF	12	273BSA-15	95
15/25/35PCJ1QX	65	167BSA-10	95	273BSA-18	95
15/25/35PCJ2HX	65	167BSA-12	95	273BSA-21	95
15/25/35PCJ2JX	65	167BSA-15	95	273DEL R-W5X	10
15/25/35PCJ2KX	65	167BSA-18	95	273DRG	11
15/25/35PCJ2LX	65	167BSA-3	95	273ELR-W5X	10
15/25/35PCJ2MX	65	167BSA-6	95	273ESA-10	95
15/25/35PCJ2NX	65	167DEL R-W5X	10	273ESA-12	95
15/25/35PCJ2PX	65	167DRG	11	273ESA-15	95
15/25/35PCJ2QX	65	167ELR-W5X	10	273ESA-18	95
15/25PCJ1LMX	65	167ESA-10	95	273ESA-21	95
15/25PCJ2GX	65	167ESA-12	95	273PSA-10	95
150BA	16	167ESA-15	95	273PSA-12	95
150TB1	17	167ESA-18	95	273PSA-15	95
150TB2	17	167ESA-3	95	273PSA-18	95
150TB3	17	167ESA-6	95	273PSA-21	95
150TB4	17	167LRT-W5X	11	273RLR-W5X	10
150TB5	17	167PSA-10	95	274DEL R-W5X	10
150TB6	17	167PSA-12	95	274DRG	11
151GP	16	167PSA-15	95	274ELR-W5X	10
152EA-W	17	167PSA-18	95	274FT	11
156LRF DP	16	167PSA-3	95	274FT2-AB	11
15PCJ1FX	65	167PSA-6	95	274FT3-AB	11
15PCJ1GX	65	167RLR-W5X	10	274FT4-AB	11
15PCJ2FX	65	168DEL R-W5X	10	274FTV	11
1601A4	11	168DRG	11	274J2	12
1601EA4	11	168ELR-W5X	10	274J2-5	12

## Appendix

### Part number index

Cat. no.	Page	Cat. no.	Page	Cat. no.	Page
274J3	12	600SW	22	750CP	22
274J3-5	12	600YADT-2	48, 52	750ETP	22, 34
274J4	12	650ARR-X	22, 52	750GP	22
274J4-5	12	650BA	52	750J2	26
274RLR-W5X	10	650BAW	52	750J3	26
274SOP	11	650CAB	30	750J4	26
276BWP	11	650ET	34	750L12	76
3701A3	11	650ETP	22, 34	750LB	30
3701A4	11	650GP	22	750LBM-3	30
3702A1	11	650GYDR	52	750LK-C	30
370GLR	11, 30, 34	650LK-C	30	750LK-C-VB	30
370TR	11, 30, 34	650LK-C-VB	30	750LRTPA2	34
371FT	11	650LRTPA3	34	750S1	76
372SOP	11	650RSC	30	750SA	22
373FT	11	650SA	22	750SOP	22
373FT2-AB	11	650VSA	22	750T1	76
373FT3-AB	11	650YGP	52	750VSA	22
373FT4-AB	11	655BCETP	60	755BE	22
373FTV	11	655BEA3	34	755BEA2	34
373J2	12	655BI-LINK-C-LR-WOX-DRG	30	755BI-LINK-C-LR-WOX-DRG	30
373J2-5	12	655CA-W	22, 52	755BLR	21
373J3	12	655CETPWOX	61	755BVS	21
373J3-5	12	655CETPW0XDRG	61	755CA-W	22
373J4	12	655CK-WOX	22, 30, 34	755CK-WOX	22, 30, 34
373J4-5	12	655CK-WOX-ARR	22, 52	755DLR-WOX	21
375BSA-24	97	655ETP-WOX-DRG	33	755ESA-18	97
375BSA-27	97	655LINK-C-LR-WOX-A-DRG	30	755ESA-24	97
375BSA-30	97	655LINK-C-LR-WOX-B-DRG	30	755ESA-27	97
375DRG	11	655LRTP-WOX-DRG	33	755ESA-30	97
375ESA-24	97	655RETP	33	755ESA-33	97
375ESA-27	97	655RLRTP	33	755ESA-36	97
375ESA-30	97	655TCK-WOX	34	755ESA-40.5	97
375ESA-36	97	656BCETP	60	755ETP-WOX-DRG	33
375LRF	12	656CETPWOX	61	755L1	26
375LR-W5X	10	656CETPW0XDRG	61	755L2-WOX	26
375PSA-24	97	675BCETP	60	755L3-WOX	26
375PSA-27	97	675CETPW2X	61	755L4-WOX	26
375PSA-30	97	675CETPW2XDRG	61	755LINK-C-LR-WOX-A-DRG	30
376DRG	11	675CETPW5X	61	755LINK-C-LR-WOX-B-DRG	30
376LR-W5X	10	675CETPW5XDRG	61	755LRTP-WOX-DRG	33
438609	16	676BCETP	60	755LR-WOX	21
600-570	46	676CETPW2X	61	755TCK-WOX	34
600AT	34	676CETPW2XDRG	61	755VSL2-WOX	26
600ATM	22, 26, 34	676CETPW5X	61	755VSL3-WOX	26
600BC	76	676CETPW5XDRG	61	755VSL4-WOX	26
600CK	76	69TCJS1	99	756BLR	21
600ECS	75	69TCJS3	99	756DLR-WOX	21
600ECSG1-2	75	69TCJS4	99	756DR	22
600ECSG2-2	75	69TCT	103	756DRG	22
600ECSG3	75	750BIP	22	756LR-WOX	21
600RRT-2	48, 52	750CAB	30	776B20GADDRK	46

## Appendix

### Part number index

Cat. no.	Page	Cat. no.	Page	Cat. no.	Page
776BGADDRK	46	K1501J2-U8	16	K650SOP	22
776GADDRK	46	K1501J3-U8	16	K650SRA	21
EACT-0300	36	K1501J4-U8	16	K650T1	76
EACT-0500	36	K1502A1	16	K650TBC	76
EACT-0750	36	K150DP	16	K650YBIP	52
EACT-1250	36	K150DR	16	K651CP	22
EACT-1500	36	K150S	17	K655BCBW	60
GLA	70	K150T	17	K655BCCP	60
GLB	70	K151LS-WOX	17	K655BCETP	60
GMA	70	K151LY-WOX	17	K655BE	22
GMB	70	K151SOP	16	K655BEA2	34
J2 - ____ - 15	55	K151SP-WOX	16	K655BI-LINK-C-LR-WOX-DRG	30
J2 - ____ - 15-SV	55	K151SR-WOX	16	K655BLR	21
J2 - ____ - 25	55	K1601PC-S1	76	K655BRLR	48
J2 - ____ - 25-SV	55	K1601PC-S1-R	76	K655BSR	21
J2 - ____ - 35	55	K1601PC-S2	76	K655BVS	21
J2 - ____ - 35-SV	55	K1601PC-S2-CK3H	76	K655CBWWOX	61
J3 - _____ - 15	55	K1601PC-S2-CK4H	76	K655CBWWOXBWP	61
J3 - _____ - 15-SV	55	K1601PC-S2-R	76	K655CCPW0X	61
J3 - _____ - 25	55	K1601PC-T1	76	K655CCPW0XDRG	61
J3 - _____ - 25-SV	55	K1601PC-T1-R	76	K655CETPW0X	61
J3 - _____ - 35	55	K1601PC-T2	76	K655CETPW0XDRG	61
J3 - _____ - 35-SV	55	K1601PC-T2-R	76	K655DLR-WOX	21
J4 - _____ - 15	55	K1601WFT	11	K655DSR-WOX	21
J4 - _____ - 15-SV	55	K1601WFTV	11	K655ESA-10	95
J4 - _____ - 25	55	K1601WJ2	12	K655ESA-12	95
J4 - _____ - 25-SV	55	K1601WJ2-5	12	K655ESA-15	95
J4 - _____ - 35	55	K1601WJ3	12	K655ESA-18	95
J4 - _____ - 35-SV	55	K1601WJ3-5	12	K655ESA-21	95
J5 - _____ - 15	55	K1601WJ4	12	K655ETP-WOX-DRG	33
J5 - _____ - 15-SV	55	K1601WJ4-5	12	K655L1	26
J5 - _____ - 25	55	K180C4	76	K655L2-WOX	26
J5 - _____ - 25-SV	55	K180S4	76	K655L3-WOX	26
J5 - _____ - 35	55	K180T4	76	K655L4-WOX	26
J5 - _____ - 35-SV	55	K650BIP	22	K655LINK-C-LR-WOX-A-DRG	30
J5 - 66666 - 25CU	55	K650CAB	30	K655LINK-C-LR-WOX-B-DRG	30
J5 - 66666 - 35CU	55	K650CP	22	K655LRTP-WOX-DRG	33
J6 - _____ - 15	55	K650ETP	22, 34	K655LR-WOX	21
J6 - _____ - 15-SV	55	K650J2	26	K655RETP	33
J6 - _____ - 25	55	K650J3	26	K655RLRTP	33
J6 - _____ - 25-SV	55	K650J4	26	K655SR-WOX	21
J6 - _____ - 35	55	K650LB	30	K655VSL2-WOX	26
J6 - _____ - 35-SV	55	K650LBM-3	30	K655VSL3-WOX	26
J6 - 666666 - 25CU	55	K650LK-C	30	K655VSL4-WOX	26
J6 - 666666 - 35CU	55	K650LK-C-VB	30	K655YBSR	51
JB-1	70	K650LRTPA2	34	K655YDR	52
JB-2	70	K650RTP	22	K655YDSR-WOX	51
JB-3	70	K650RTW	22	K655YSR-WOX	51
JB-4	70	K650S1	76	K656BCBW	60
K1501A1	16	K650SL	48	K656BCCP	60
K1501FT	16	K650SLGB	48	K656BCETP	60

## Appendix

### Part number index

Cat. no.	Page	Cat. no.	Page	Cat. no.	Page
K656BELR	48	K676BCBW	60	R2IT15J4	69
K656BLR	21	K676BCCP	60	R2IT15L1	69
K656BRLR	48	K676BCETP	60	R2IT15L2	69
K656BSELR	48	K676BGADDRK	46	R2IT15L4	69
K656CBWWOX	61	K676CBWW2X	61	R2IT15M1	69
K656CBWWOXBWP	61	K676CBWW2XBWP	61	R2IT15M2	69
K656CCPW0X	61	K676CBWW5X	61	R2IT15M4	69
K656CCPW0XDRG	61	K676CBWW5XBWP	61	R2T15J1	69
K656CETPW0X	61	K676CCPW2X	61	R2T15J2	69
K656CETPW0XDRG	61	K676CCPW2XDRG	61	R2T15J4	69
K656CH-BUS	51	K676CCPW5X	61	R2T15L1	69
K656CH-HP	51	K676CCPW5XDRG	61	R2T15L2	69
K656CHSL	48	K676CETPW2X	61	R2T15L4	69
K656CW0X	51	K676CETPW2XDRG	61	R2T15M1	69
K656CY-BUS	51	K676CETPW5X	61	R2T15M2	69
K656CY-HP	51	K676CETPW5XDRG	61	R2T15M4	69
K656CYSL	48	K676GADDRK	46	R2T28J2	69
K656CY-W0X	51	L1601PC-S1	76	R2T28J4	69
K656DLR-W0X	21	L1601PC-S1-R	76	R2T28L2	69
K656DR	22	L1601PC-S2	76	R2T28L4	69
K656DRG	22	L1601PC-S2-CK3H	76	R2T28M2	69
K656ELR-W0X	48	L1601PC-S2-CK4H	76	R2T28M4	69
K656ELR-WOX	48	L1601PC-S2-R	76	R2T35J2	69
K656I-BUS	51	L1601PC-T1	76	R2T35J4	69
K656I-HP	51	L1601PC-T1-R	76	R2T35L2	69
K656ISL	48	L1601PC-T2	76	R2T35L4	69
K656I-W0X	51	L1601PC-T2-R	76	R2T35M2	69
K656LR-W0X	21	M276BWP	11	R2T35M4	69
K656SELR-W0X	48	M650YBIP	52	VSGADCP-25	42
K656SELR-WOX	48	M655YBSR	51	VSGADCP-35	42
K656YBDSR	51	M655YDR	52		
K656YDSR-W0X	51	M655YDSR-W0X	51		
K675BCBW	60	M655YSR-W0X	51		
K675BCCP	60	M656CH-BUS	51		
K675BCETP	60	M656CH-HP	51		
K675CBWW2X	61	M656CW0X	51		
K675CBWW2XBWP	61	M656CY-BUS	51		
K675CBWW5X	61	M656CY-HP	51		
K675CBWW5XBWP	61	M656CY-W0X	51		
K675CCPW2X	61	M656I-BUS	51		
K675CCPW2XDRG	61	M656I-HP	51		
K675CCPW5X	61	M656I-W0X	51		
K675CCPW5XDRG	61	M656YBDSR	51		
K675CETPW2X	61	M656YDSR-W0X	51		
K675CETPW2XDRG	61	PB-1	73		
K675CETPW5X	61	PCT1-1X-4	73		
K675CETPW5XDRG	61	PCT1-4	73		
K675S1	76	PCT2-1X-4	73		
K675T1	76	PCT2-4	73		
K675TBC	76	R2IT15J1	69		
K676B20GADDRK	46	R2IT15J2	69		



**Additional information**

ABB has made every attempt to ensure the accuracy and reliability of the contents of this document. However, all content is provided for general informational purposes only, and ABB makes no guaranty or warranty, express or implied, as to the accuracy of any technical content, or that the information contained in this publication will be error free and all such guarantees or warranties are expressly disclaimed. ABB may change or modify the contents at any time, without prior notice. We reserve all rights in this document and in the subject matter and illustrations contained therein. Any reproduction or utilization of its contents — in whole or in parts — is forbidden without prior written consent of ABB.





—  
**US**

ABB Installation Products Inc.  
Electrification business

**[electrification.us.abb.com](http://electrification.us.abb.com)**