

Python® Cable Accessories

Extruded Dielectric Cable 69kV-345kV Rating



G&W Electric's portfolio of transmission cable accessories reflects our long history of industry-leading research and development. We are a pioneer in the design and manufacturing of quality cable accessories, with a long history of expertise that actively contributes to development standards for IEEE.

G&W Electric offers a variety of transmission cable accessories for extruded dielectric cable systems. Accessories are available for extruded, self-contained and pipe type cables for outdoor and equipment mount applications. Our power cable accessories are designed to the latest industry standards to ensure time-proven, reliable system performance.

- Components used in cable systems
- 100% Tested
- Factory Molded
- For outdoor applications through 345kV
- For gas insulated substations and transformers through 345kV
- Dry type designs available for easy installation
- Mechanical Shrink installation option available

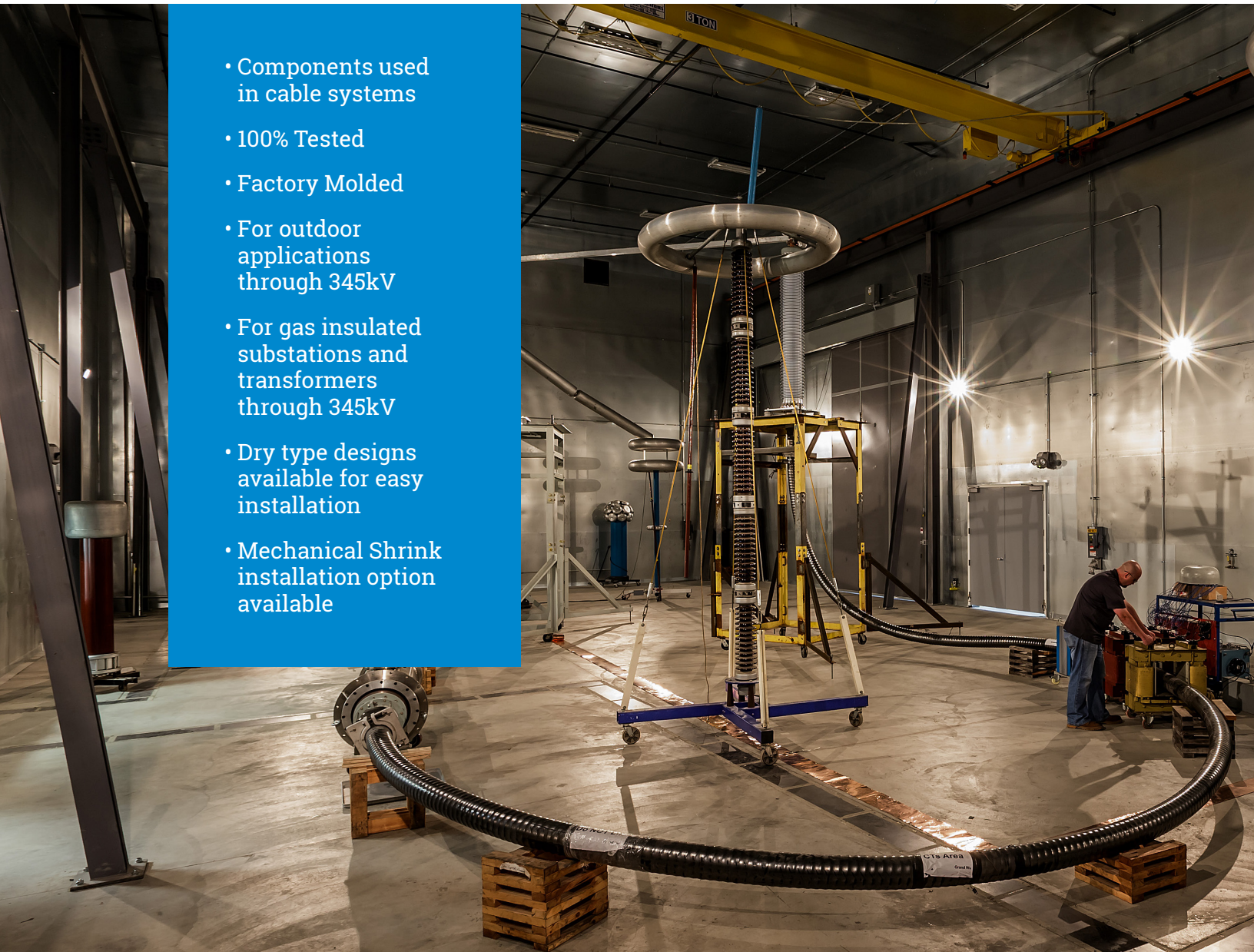

G&W Electric's high voltage testing laboratory in Bolingbrook, IL



PYTHON® SERIES

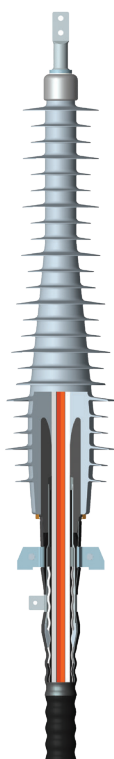

Dry Type Outdoor Terminations

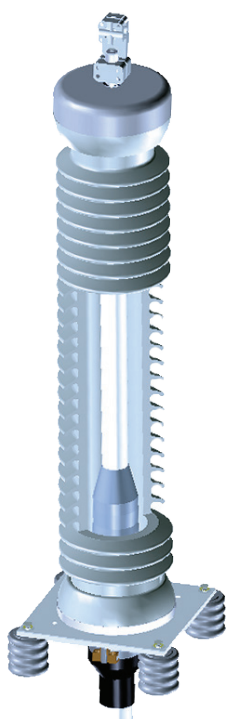

Outdoor Terminations

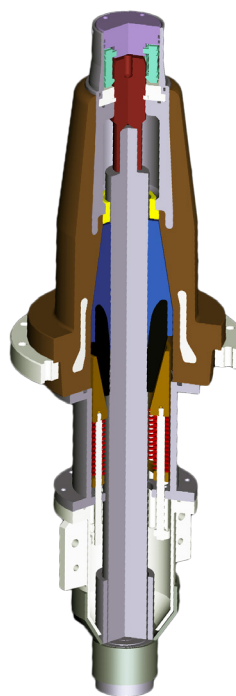

Dry GIS and Transformer Terminations

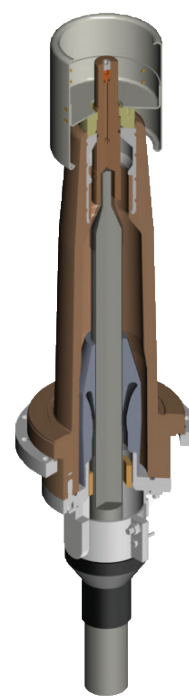

GIS and Transformer Terminations



Premolded Joint

Dry Type Outdoor Terminations

G&W Electric's Python premolded dry type outdoor terminations are available for 145kV IEC (138kV IEEE) XLPE and EPR cable systems.

FEATURES

- Lightweight
- Dry type premolded termination body
- Flexible design
- Vertical, horizontal or angled mounting positions
- Mechanical shrink installation
- Tested to IEC 60840

STANDARD COMPONENTS

1. Conductor Connector
(Crimp type connectors supplied as standard)
2. Hood nut
3. Corona shield cap
4. Termination body
5. Stress Cone
6. Position and cushion ring
7. Slip ring
8. Cable entrance housing
9. Insulation and seal tapes
10. Mounting bracket
11. Heat shrink tube
12. Grounding plate
13. Wiping seal

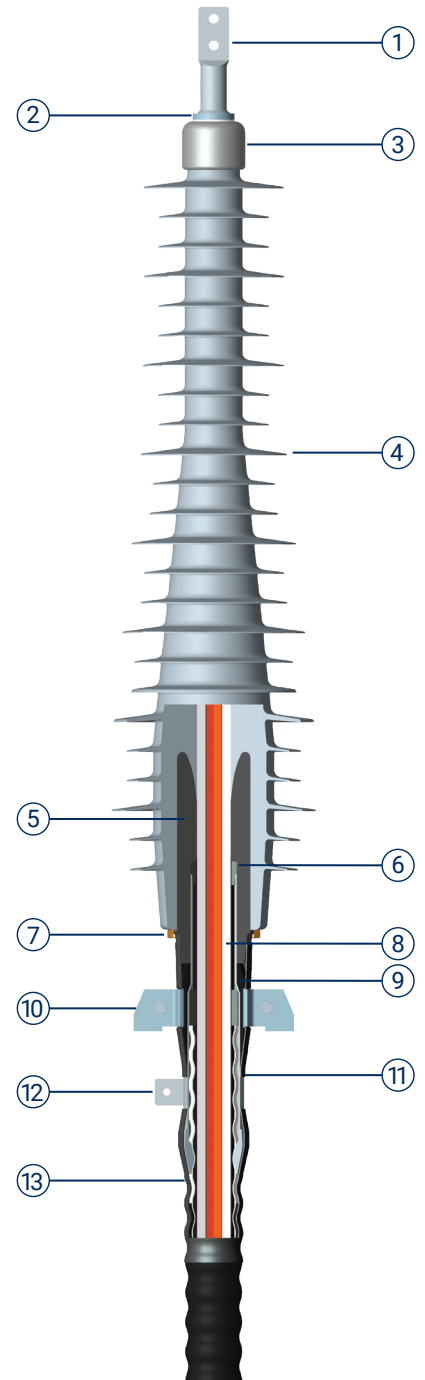

APPLICATION RANGE EPR, XLPE CABLE

CONDUCTOR MATERIAL	CONDUCTOR SIZE	INSULATION DIAMETER
145 (138) kV		
Copper	240mm ² - 1600 mm ² (500 kcmil - 3000 kcmil)	59mm - 90mm (2.32 in. - 3.54 in.)
Aluminum	2400mm ² - 1200mm ² (500 kcmil - 2500 kcmil)	59mm - 90mm (2.32 in. - 3.54 in.)

CATALOG NUMBER BUILDER

Use the chart below to build your G&W Electric catalog number. This number should be used for all inquiries and quote requests. In addition, the following cable information is required to process your order:

1. Conductor size and O.D. of conductor (nominal and max)
2. Insulation O.D. (min and max)
3. Insulation shield O.D. (min and max)
4. Jacket O.D. (nominal and max)
5. Cable construction details with metallic sheath type and fault current rating

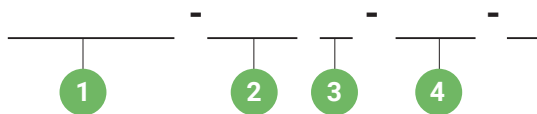

1 Basic Termination

Rated Voltage kV (IEC)	Rated Voltage kV (IEEE)	BIL (kV)	Code
145	138	650	PAT 130C

2 Conductor Size (See Application Range Chart)

SIZE mm ²	Code	kcmil	Code
240	240M	500	500K
300	300M	750	750K
400	400M	1000	1000K
500	500M	1250	1250K
630	630M	1500	1500K
800	800M	1750	1750K
1000	1000M	2000	2000K
1200	1200M	2500	2500K

3 Conductor Material

Material	Code
Copper	C
Aluminum	A

4 Aerial Connection

Description	Code
2-Hole, Non-rotating	2H
4-Hole NEMA, Rotating	4H

EXAMPLE:

PAT130C-630MC-2H-X

145kV termination for 630mm² copper conductor with 2-hole, non-rotating aerial connection.

Style 4 Clamp Type

Aerial Conductor Size		Aerial Lug Height Dimension		Lug Material	Code
mm ²	AWG/kcmil	inches	mm		
35-240	#2-500	7	178	Bare Copper	C1
				Tinned	C1T
				Silver Plated Copper	C1S
300-500	550-1000	7	178	Bare Copper	C2
				Tinned	C2T
				Silver Plated Copper	C2S

Aerial Lug Options

2-Hole, Non-rotating	
Underground Conductor Size	Hole I.D.
240mm ² - 300mm ² (500 kcmil - 750 kcmil)	13mm
400mm ² - 1200mm ² (1000 kcmil - 2500 kcmil)	17mm
4-Hole NEMA, Rotating	
Underground Conductor Size	Hole I.D.
240mm ² - 1200mm ² (500 kcmil - 2500 kcmil)	14.5mm

Ship Weight

Catalog Prefix	Approximate Ship Weight
PAT 130C	36 kg (80 lbs)

Outdoor Terminations

G&W Electric's Python outdoor PAT style transmission terminations are designed for extruded dielectric cable systems from 72.5kV to 362kV IEC (69kV to 345kV IEEE).

FEATURES

- Pressure tight epoxy socket insulator
- Prefabricated silicone rubber stress cone
- Application range is 240mm² - 2500mm² XLPE cable
- Meet or exceed requirements of IEC 60840, IEC 62067, IEEE 48, IEEE 404 and AEIC CS9-06

STANDARD COMPONENTS

1. Aerial lug specified by user
2. Connector (Crimp type connectors supplied as standard)
3. Aluminum cap plate
4. Aluminum corona shield
5. Insulator
6. Dielectric fluid
7. Premolded rubber stress cone
8. Aluminum entrance housing with heat shrink seal, standoff insulators (4) and galvanized steel mounting plate
9. Cable preparation kit

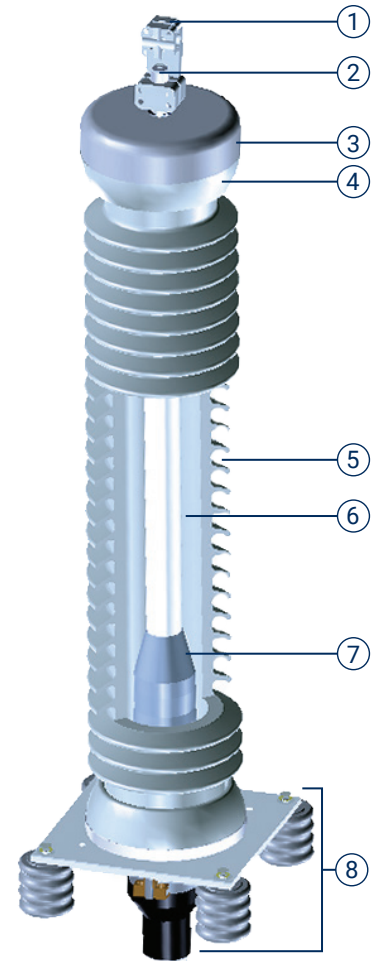

APPLICATION RANGE

CONDUCTOR MATERIAL	CONDUCTOR SIZE	INSULATION DIAMETER**
72.5 (69kV)		
Copper	240mm ² - 2000mm ² (500 kcmil - 4000 kcmil)	40.5mm - 93.2mm (1.59in. - 3.67in.)
Aluminum*	240mm ² - 2000mm ² (500 kcmil - 4000 kcmil)	
145 (138) kV		
Copper	240mm ² - 2000mm ² (500 kcmil - 4000 kcmil)	43mm - 106.5mm (1.69in. - 4.19in.)
Aluminum*	240mm ² - 2000mm ² (500 kcmil - 4000 kcmil)	
170 (161kV)		
Copper	240mm ² - 1600mm ² (500 kcmil - 4000 kcmil)	43mm - 106.5mm (1.69in. - 4.19in.)
Aluminum*	240mm ² - 1200mm ² (500 kcmil - 4000 kcmil)	
245 (230kV)		
Copper	400mm ² - 2500mm ² (750 kcmil - 5000 kcmil)	65mm - 124.9mm (2.55in. - 4.92in.)
Aluminum*	400mm ² - 2500mm ² (750 kcmil - 5000 kcmil)	
362 (345kV)		
Copper	1200mm ² - 2500mm ² (2500 kcmil - 5000 kcmil)	104mm - 133.5mm (4.1in. - 5.26in.)
Aluminum	1200mm ² - 2500mm ² (2500 kcmil - 5000 kcmil)	

*Aluminum conductors larger than 1200mm² (2500 kcmil) may require special conductor connection provisions.

**Contact your G&W Electric representative for additional cable sizes

Insulator Options

- Gray porcelain
- Brown porcelain
 - Blends with existing installations
- Silicone rubber, composite insulator
 - Less than one third the weight of porcelain insulator
 - Will not break or fracture
 - Fire and UV resistant

Cable Suspension Grip Option

- Supplied with:
- Stainless steel cable grip
 - Turnbuckles (2)
 - Eyebolts (2)

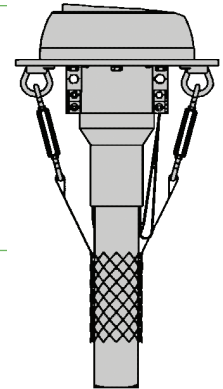

Arcing Horns Option

- Prevents damage to insulator due to significant overvoltage conditions
- Provides an alternate current path away from the insulator
- Adjustable to system requirements

Aerial Lug Options

Style 4 Clamp Type

Aerial Conductor Size		Lug Material	Code
mm ²	AWG/kcmil		
35-240	#2-500	Bare Copper	C1
		Tinned	C1T
		Silver Plated Copper	C1S
300-500	550-1000	Bare Copper	C2
		Tinned	C2T
		Silver Plated Copper	C2S

Style 8 NEMA 4-Hole Type

Description	Code
Bare Copper	NX
Tin Plated Copper	NT
Silver Plated Copper	NS

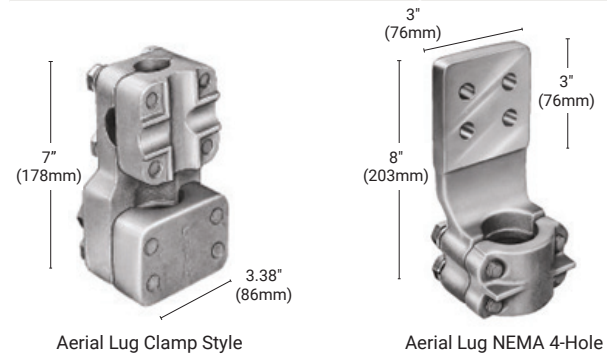

Dielectric Fluid Volume Compensating System

- Required for proper performance in horizontal or inverted termination installations.
- Compensates for dielectric fluid expansion and contraction caused by temperature fluctuations.
- Supplied with:
 - Dielectric fluid reservoir with internal gas bladder
 - Insulating hose
 - Optional alarm device to signal accidental loss of dielectric fluid
- Contact your G&W Electric representative for additional information.

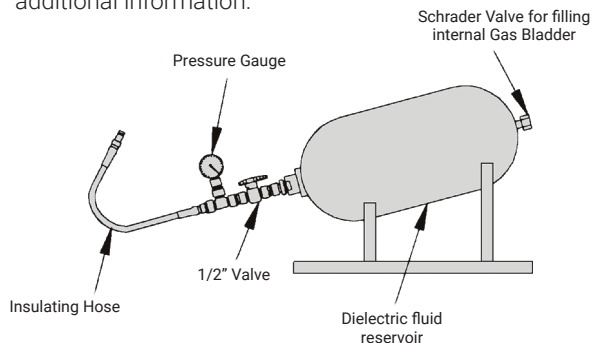

Drain Valve Option

- Permits sampling of the dielectric fluid
- Located on base plate
- Required if volume compensating system option is specified

Ship Weight

Catalog Prefix	Approximate Ship Weight	
	Porcelain	Composite
PAT119	150 kg (327 lbs)	100 kg (217 lbs)
PAT140	270 kg (592 lbs)	220 kg (485 lbs)
PAT150	290 kg (639 lbs)	188 kg (415 lbs)
PAT160	1068 kg (2337 lbs)	780 kg (1710 lbs)
PAT180	2540 kg (5600 lbs)	2540 kg (5600 lbs)

CATALOG NUMBER BUILDER

Use the chart below to build your G&W Electric catalog number. This number should be used for all inquiries and quote requests. In addition, the following cable information is required to process your order:

1. Conductor size and O.D. of conductor (nominal and max)
2. Insulation O.D. (min and max)
3. Insulation shield O.D. (min and max)
4. Jacket O.D. (nominal and max)
5. Cable construction details with metallic screen type and fault current rating



EXAMPLE:

PAT140-3540G-630MC-X-C1T-X-X

145kV termination with gray porcelain insulator for 630mm² copper conductor, mounting plate with standoff insulators, aluminum entrance housing and heat shrink seals, with clamp style, tinned copper aerial lug for 240mm² maximum overhead conductor with standard, mechanical shrink installation.

1 Basic Termination

Rated Voltage kV (IEC)	Rated Voltage kV (IEEE)	BIL (kV)	Code
72.5	69	350	PAT 119
145	138	650	PAT 140
170	161	750	PAT 150
245	230	1050	PAT 160
362	345	1300	PAT 180

2 Insulator- Material, Color, and Creepage

PAT 119	Code
Porcelain, gray, 1702mm standard creepage	1702G
Porcelain, brown, 1702mm standard creepage	1702B
Porcelain, gray, 2464mm extra creepage	2464G
Porcelain, brown, 2464mm extra creepage	2464B
Silicone rubber, gray, 2194mm extra creepage	2194G
PAT 140	Code
Porcelain, gray, 3540mm standard creepage	3540G
Porcelain, brown, 3540mm standard creepage	3540B
Porcelain, gray, 5050mm extra creepage	5050G
Porcelain, brown, 5050mm extra creepage	5050B
Silicone rubber, gray, 4495mm extra creepage	4495G

2 Insulator- Material, Color, and Creepage

PAT 150	Code
Porcelain, gray, 4115mm standard creepage	4115G
Porcelain, brown, 4115mm standard creepage	4115B
Porcelain, gray, 5890mm extra creepage	5890G
Porcelain, brown, 5890mm extra creepage	5890B
Silicone rubber, gray, 5050mm extra creepage	5050G
PAT 160	Code
Porcelain, gray, 5221mm standard creepage	5221G
Porcelain, brown, 5221mm standard creepage	5221B
Porcelain, gray, 8006mm extra creepage	8006G
Porcelain, brown, 8006mm extra creepage	8006B
Silicone rubber, gray, 7693mm extra creepage	7693G
PAT 180	Code
Porcelain, gray, 12500mm extra creepage	12500G
Porcelain, brown, 12500mm extra creepage	12500B
Silicone rubber, gray, 12250mm extra creepage	12250G

3 Conductor Size (See Application Range Chart)

SIZE mm ²	Code	kcmil	Code
240	240M	500	500K
300	300M	750	750K
400	400M	1000	1000K
500	500M	1250	1250K
630	630M	1500	1500K
800	800M	1750	1750K
1000	1000M	2000	2000K
1200	1200M	2500	2500K
1400	1400M	3000	3000K
1600	1600M	5000	5000K
1800	1800M		
2000	2000M		
2500	2500M		

4 Conductor Material

Material	Code
Copper	C
Aluminum	A

5 Mounting/Entrance Configuration

Description	Code
Mounting plate with standoff insulators (4), aluminum entrance housing and heat shrink seals	X
Wiping sleeve for lead sheath, corrugated aluminum, or corrugated copper cable, mounting plate with standoff insulators (4)	WS

6 Aerial Lugs

Description	Code
No additional components required	X
Arcing horns	AH
Drain valve	DV
Stainless steel suspension grips	SG

7 Aerial Lug Finish

Finish	Code
None	X
Tinned	T
Silver	S

8 Additional Components

Description	Code
No additional components required	X
Arcing horns	AH
Drain valve	DV
Stainless steel suspension grips	SG

9 Installation

Description	Code
Mechanical shrink	X
Slip on: Use for spares or long term storage. Installation tool is available and is ordered separately	S

Dry GIS and Transformer Terminations

G&W Electric's Python SSC style transmission terminations are designed for gas insulated switchgear and transformer applications on extruded dielectric cable systems rated up to 362kV IEC (345kV IEEE).

FEATURES

- Pressure tight epoxy socket insulator
- Prefabricated silicone rubber stress cone
- Dry type design, no oil filling of the termination required
- Dimensions meet the requirements of IEC 62271-209
- Application range is 240mm² - 2500mm² XLPE cable
- Meet or exceed requirements of IEC 60840, IEC 62067, IEEE 48, IEEE 404 and AEIC CS9-06

STANDARD COMPONENTS

1. Contact Pad
2. Quick connect assembly
3. Connector
4. Stress cone stopper
5. Epoxy Insulator
6. Premolded rubber stress cone
7. Clamping ring
8. Stress cone compression kit
9. Entrance housing
10. Heat shrink tube

Note: Standard kit also includes: grease, sandpaper, PVC tape, heat shrink seal, solder, flux, tinned copper ground braid and grounding lugs.

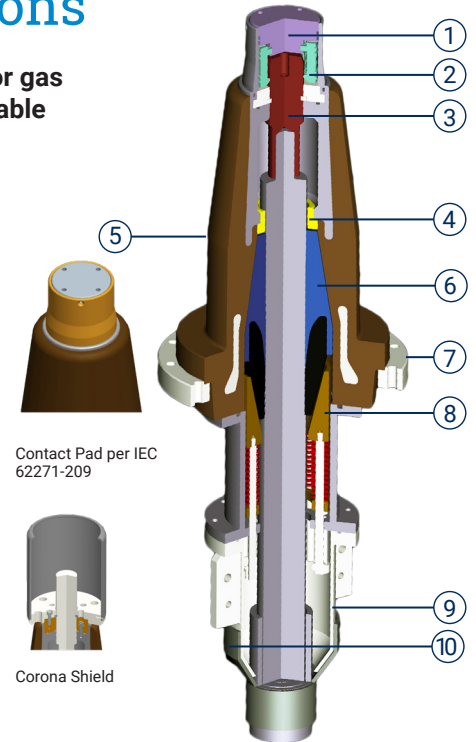

APPLICATION RANGE

CONDUCTOR MATERIAL	CONDUCTOR SIZE	INSULATION DIAMETER**
145 (138) kV		
Copper	240mm ² - 2000mm ² (500kcmil - 4000kcmil)	57.5mm - 101.5mm (2.26 in. - 3.99 in.)
Aluminum*	240mm ² - 1200mm ² (500kcmil - 2500kcmil)	
Plug-in/Plug-out 145 (138kV)		
Copper	240mm ² - 1600mm ² (500kcmil - 3200kcmil)	57.5mm - 91.5mm (2.26 in. - 3.60 in.)
Aluminum*	240mm ² - 1600mm ² (500kcmil - 3200kcmil)	
170 (161kV)		
Copper	240mm ² - 2000mm ² (500kcmil - 4000kcmil)	57.5mm - 101.5mm (2.26 in. - 3.99 in.)
Aluminum*	240mm ² - 1200mm ² (500kcmil - 2500kcmil)	
245 (230kV)		
Copper	400mm ² - 2500mm ² (750kcmil - 5000kcmil)	76.5mm - 116.5mm (3.01 in. - 4.59 in.)
Aluminum*	400mm ² - 1200mm ² (750kcmil - 2500kcmil)	
Plug-in/Plug-out 245 (230kV)		
Copper	400mm ² - 1600mm ² (750kcmil - 3200kcmil)	73mm - 108mm (2.87 in. - 4.25 in.)
Aluminum*	400mm ² - 1600mm ² (750kcmil - 3200kcmil)	
362 (345kV)		
Copper	1200mm ² - 2500mm ² (2500kcmil - 5000kcmil)	104mm - 133.5mm (4.10 in. - 5.26 in.)
Aluminum	1200mm ² (2500kcmil) only	

* Aluminum conductors larger than 1200mm² (2500 kcmil) may require special conductor connection provisions.

** Contact your G&W Electric representative for additional cable sizes.

CATALOG NUMBER BUILDER

Use the chart below to build your G&W Electric catalog number. This number should be used for all inquiries and quote requests. In addition, the following cable information is required to process your order:

1. Conductor size and O.D. of conductor (nominal and max)
2. Insulation O.D. (min and max)
3. Insulation shield O.D. (min and max)
4. Jacket O.D. (nominal and max)
5. Cable construction details with metallic screen type and fault current rating.



EXAMPLE:

SSC140-SF-X-630MC

145kV termination with IEC 62271-209 contact pad for 630mm² copper conductor.

1 System Voltage

Rated Voltage kV (IEC)	Rated Voltage kV (IEEE)	BIL (kV)	Code
145	138	650	SSC140
170	161	750	SSC150
245	230	1050	SSC160
362	345	1300	SSC180

2 Connection Type

Description	Code
Stem Connector*	X
Contact Pad per IEC 62271-209	SF

*If stem connector option is chosen, aerial lug option can be chosen from page 6.

3 Corona Shield Option

Description	Code
None	X
Corona Shield	CS

4 Conductor Size (See Application Range Chart)

SIZE mm ²	Code	kcmil	Code
240	240M	500	500K
300	300M	750	750K
400	400M	1000	1000K
500	500M	1250	1250K
630	630M	1500	1500K
800	800M	1750	1750K
1000	1000M	2000	2000K
1200	1200M	2500	2500K
1400	1400M	3000	3000K
1600	1600M	5000	5000K
1800	1800M		
2000	2000M		
2500	2500M		

5 Conductor Material

Description	Code
Copper	C
Aluminum	A

Ship Weight

Catalog Prefix	Approximate Ship Weight
SSC140	90 kg (199 lbs)
SSC150	90 kg (199 lbs)
SSC160	110 kg (243 lbs)
SSC180	600 kg (1323 lbs)

CATALOG NUMBER BUILDER FOR PLUG-IN/PLUG-OUT

Use the chart below to build your G&W Electric catalog number. This number should be used for all inquiries and quote requests. In addition, the following cable information is required to process your order:

1. Conductor size and O.D. of conductor (nominal and max)
2. Insulation O.D. (min and max)
3. Insulation shield O.D. (min and max)
4. Jacket O.D. (nominal and max)
5. Cable construction details with metallic screen type and fault current rating.



EXAMPLE:

SSC140-X-P-X-630M-C

145kV plug-in termination with IEC 62271-209 contact pad for 630mm² copper conductor.

1 System Voltage

Rated Voltage kV (IEC)	Rated Voltage kV (IEEE)	BIL (kV)	Code
145	138	650	SSC140
245	230	1050	SSC160

2 Connection Type

Description	Code
Stem Connector*	X-P
Contact Pad per IEC 62271-209	SF-P

*If stem connector option is chosen, aerial lug option can be chosen from page 6.

3 Corona Shield Option

Description	Code
None	X
Corona Shield	CS

4 Conductor Size (See Application Range Chart)

Size mm ²	Code	kcmil	Code
240	240M	500	500K
300	300M	750	750K
400	400M	1000	1000K
500	500M	1250	1250K
630	630M	1500	1500K
800	800M	1750	1750K
1000	1000M	2000	2000K
1200	1200M	2500	2500K
1400	1400M	3000	3000K
1600	1600M	3200	3200K

5 Conductor Material

Description	Code
Copper	C
Aluminum	A

Ship Weight

SSC140	90kg (199lbs)
SSC160	90kg (199lbs)

GIS and Transformer Terminations

G&W Electric's Python PATR style transmission terminations are designed for gas insulated substation and oil immersed equipment applications on extruded dielectric cable systems rated: 72.5kV, 145kV, and 245kV IEC (69kV, 138kV, 230kV IEEE)

FEATURES

- Stress Cone: Factory molded and 100% tested
- Available with mechanical shrink or slip on installation method
- 69kV and 138kV are type tested per applicable requirements of IEEE 48 and IEC 60840
- 230kV is prequalification and type tested per IEC 62067
- Suitable for XLPE and EPR cables

STANDARD COMPONENTS

1. Equipment connection:
 - Contact pad style suitable for GIS or oil immersed transformer applications
 - Stem connector style suitable for oil immersed transformer applications. Various styles of aerial lugs are available for stem connector design.
2. Connector with double "O"-ring seal
3. Epoxy insulator with built-in cable shield break
4. Dielectric fluid
5. Premolded rubber stress cone
6. Aluminum clamping ring
7. Aluminum base plate
8. Aluminum entrance housing with heat shrink seal

Note: Standard kit also includes: grease, sandpaper, PVC tape, heat shrink seal, solder, flux, tinned copper ground braid and grounding lugs.

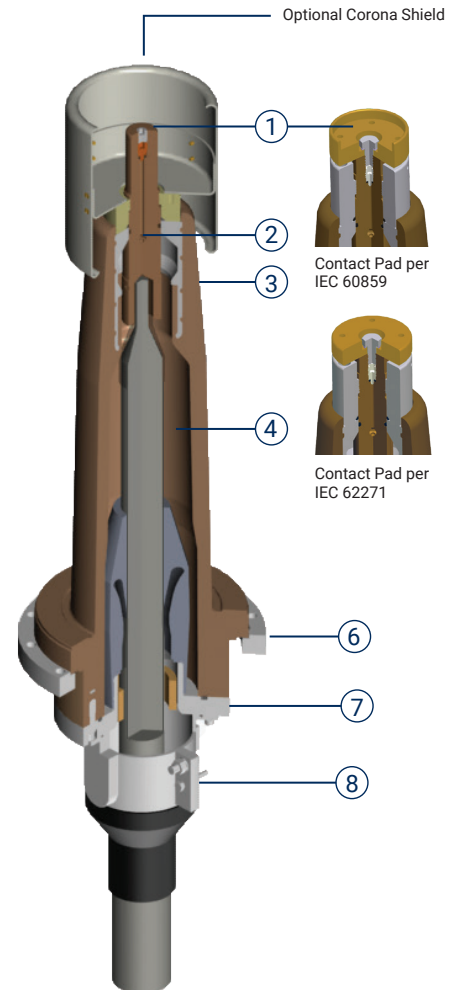

APPLICATION RANGE

CONDUCTOR MATERIAL	CONDUCTOR SIZE	INSULATION DIAMETER
72.5 (69) kV		
Copper	240mm ² - 1600mm ² (500 kcmil - 3000 kcmil)	40.5mm - 90mm (1.59 in. - 3.54 in.)
Aluminum*	240mm ² - 1200mm ² * (500 kcmil - 2500 kcmil)	
145 (138) kV		
Copper	240mm ² - 2000mm ² (500 kcmil - 4000 kcmil)	43mm - 106.5mm (1.69 in. - 4.19 in.)
Aluminum*	240mm ² - 1200mm ² * (500 kcmil - 2500 kcmil)	
245 (230) kV		
Copper	400mm ² - 2500mm ² (750 kcmil - 5000 kcmil)	65mm - 124.9mm (2.55 in. - 4.92 in.)
Aluminum*	400mm ² - 1200mm ² * (750 kcmil - 2500 kcmil) *	

** Aluminum conductors larger than 800mm² (1600 kcmil) may require special conductor connection provisions. Contact your G&W Electric representative for additional cable sizes.*

Aerial Lug Options

Style 4 Clamp Type

Aerial Conductor Size		Aerial Lug Height Dimension		Lug Material	Code
mm ²	AWG/kcmil	inches	mm		
35-240	#2-500	7	178	Bare Copper	C1
				Tinned	C1T
				Silver Plated Copper	C1S
300-500	550-1000	7	178	Bare Copper	C2
				Tinned	C2T
				Silver Plated Copper	C2S

Style 8 NEMA 4-Hole Type

Description	Code
Bare Copper	N
Tin Plated Copper	NT
Silver Plated Copper	NS

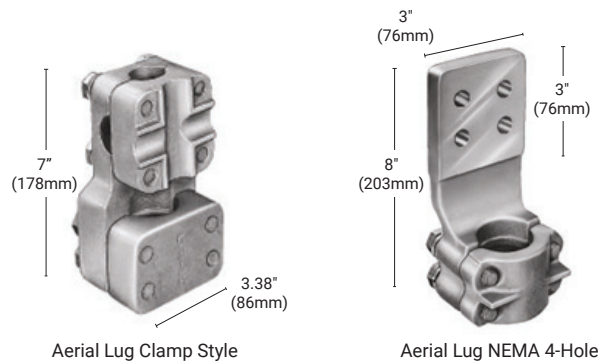

Dielectric Fluid Volume Compensating System

- Required for proper performance in horizontal or inverted termination installations.
- Compensates for dielectric fluid expansion and contraction caused by temperature fluctuations.
- Supplied with:
 - Dielectric fluid reservoir with internal gas bladder
 - Insulating hose
 - Optional alarm device to signal accidental loss of dielectric fluid
- Contact your G&W Electric representative for additional information.

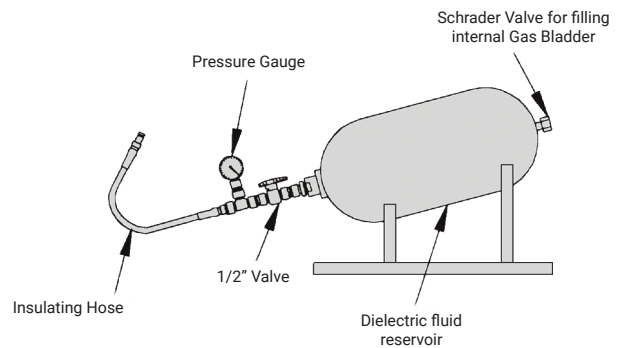

Oil Filling Kit

- Required for filling terminations during installation.
- Kit must be ordered separately.
- Kit can be used to fill multiple terminations. G&W Electric recommends ordering one oil filling kit per six terminations ordered.
- Supplied with:
 - Pump
 - Valves and fittings
 - Hose (2 meters)
 - Sight glass

Connectors

Connection Type	Code
Stem Connector	X
Contact Pad per IEC 60859	SF
Contact Pad per IEC 62271-209	SG

- Crimp type connectors supplied as standard
- Shear bolt connectors available

Ship Weight

Catalog Prefix	Approximate Ship Weight
PATR119	72 kg (160 lbs)
PATR140	90 kg (200 lbs)
PATR160	177 kg (390 lbs)

CATALOG NUMBER BUILDER

Use the chart below to build your G&W Electric catalog number. This number should be used for all inquiries and quote requests. In addition, the following cable information is required to process your order:

1. Conductor size and O.D. of conductor (nominal and max)
2. Insulation O.D. (min and max)
3. Insulation shield O.D. (min and max)
4. Jacket O.D. (nominal and max)
5. Cable construction details with metallic screen type and fault current rating



EXAMPLE:

PATR140-X-CS-630MC-X-C1S-X
 145kV termination with stem connector and corona shield for 630mm² copper conductor with clamp style, silver plated aerial lug, with standard, mechanical shrink installation.

1 System Voltage

Rated Voltage kV (IEC)	Rated Voltage kV (IEEE)	BIL (kV)	Code
72.5	69	350	PATR119
145	138	650	PATR140
245	230	1050	PATR160

4 Conductor Size (See Application Range Chart)

SIZE mm ²	Code	kcmil	Code
240	240M	500	500K
300	300M	750	750K
400	400M	1000	1000K
500	500M	1250	1250K
630	630M	1500	1500K
800	800M	1750	1750K
1000	1000M	2000	2000K
1200	1200M	2500	2500K
1400	1400M	3000	3000K
1600	1600M	5000	5000K
1800	1800M		
2000	2000M		
2500	2500M		

2 Connectors

Connection Type	Code
Stem Connector	X
Contact Pad per IEC 60859	SF
Contact Pad per IEC 62271-209	SG

3 Corona Shield Option

Description	Code
None	X
Corona Shield	CS

CATALOG NUMBER BUILDER (continued)

Use the chart below to build your G&W Electric catalog number. This number should be used for all inquiries and quote requests. In addition, the following cable information is required to process your order:

1. Conductor size and O.D. of conductor (nominal and max)
2. Insulation O.D. (min and max)
3. Insulation shield O.D. (min and max)
4. Jacket O.D. (nominal and max)
5. Cable construction details with metallic screen type and fault current rating

5 Conductor Material

Description	Code
Copper	C
Aluminum	A

8 Aerial Lug Finish

Finish	Code
None	X
Tinned	T
Silver	S

6 Entrance Configuration

Description	Code
Aluminum entrance housing and heat shrink seal	X
Wiping Sleeve for lead sheath, corrugated aluminum, or corrugated copper cable, Mounting plate with standoff insulators (4)	WS

9 Installation

Description	Code
Mechanical shrink	X
Slip on: Use for spares or long term storage. Installation tool is available and is ordered separately	S

7 Aerial Lugs (Use only with stem connector)

Description	Code
No aerial lug	X
Clamp, Copper, 240mm ² max	C1
Clamp, Copper, 300mm ² - 500mm ²	C2
NEMA 4-hole, Copper	N

Premolded Joint

G&W Electric's Python premolded rubber joints (PMJ) are available from 72.5kV to 362kV (69kV to 345kV IEEE) extruded dielectric cable systems.

FEATURES

- Factory premolded joint
- 100% routine tested
- 69kV type tested per IEC60840
- 115 - 230kV type tested per IEC60840, IEC62067 and IEEE404
- 345kV type tested per IEC62067

APPLICATIONS

- Extruded dielectric cable systems, XLPE and EPR insulated
 - Cable ground shield: copper wires/tapes, corrugated aluminum or copper sheath, lead sheath
 - Direct burial, submersed or vault

OPTIONS

- Available with mechanical shrink or slip-on installation method
- Shield break or Non shield break configurations
- Available with the following options for outer protection:
 - Heat shrink tubing
 - Copper housing
- Shear bolt connectors available



APPLICATION RANGE

CONDUCTOR MATERIAL	CONDUCTOR SIZE	INSULATION DIAMETER
72.5 (69kV)		
Copper	240mm ² - 2000mm ² (500 kcmil - 4000 kcmil)	50.8mm - 93.2mm (2 in. - 3.67 in.)
Aluminum	240mm ² - 2000mm ² (500 kcmil - 4000 kcmil) *	
145 (138) kV		
Copper	240mm ² - 2000mm ² (500 kcmil - 4000 kcmil)	54mm - 98mm (2.12 in. - 3.86 in.)
Aluminum	240mm ² - 2000mm ² (500 kcmil - 4000 kcmil)	
170 (161kV)		
Copper	240mm ² - 2000mm ² (500 kcmil - 4000 kcmil)	60mm - 98mm (2.36 in. - 3.86 in.)
Aluminum	240mm ² - 2000mm ² (500 kcmil - 4000 kcmil) *	
245 (230kV)		
Copper	400mm ² - 2500mm ² (750 kcmil - 5000 kcmil)	74mm - 124mm (2.91 in. - 4.88 in.)
Aluminum	400mm ² - 2500mm ² * (750 kcmil - 5000 kcmil) *	
362 (345kV)		
Copper	800mm ² - 2500mm ² (1500 kcmil - 5000 kcmil)	95mm - 133mm (3.74 in. - 5.24 in.)
Aluminum	800mm ² - 2500mm ² (1500 kcmil - 5000 kcmil) *	

* Aluminum conductors larger than 500mm² (1000 kcmil) may require special conductor connection provisions. Contact your G&W Electric representative for additional cable sizes.

CATALOG NUMBER BUILDER

Use the chart below to build your G&W Electric catalog number. This number should be used for all inquiries and quote requests. In addition, the following cable information is required to process your order:

1. Conductor size and O.D. of conductor (nominal and max)
2. Insulation O.D. (min and max)
3. Insulation shield O.D. (min and max)
4. Jacket O.D. (nominal and max)
5. Cable construction details with metallic screen type and fault current rating

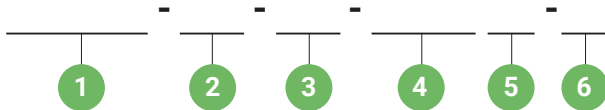

1 System Voltage

Rated Voltage kV (IEC)	Rated Voltage kV (IEEE)	BIL (kV)	Code
72	69	350	PMJ119
145	138	650	PMJ140
170	161	750	PMJ150
245	230	1050	PMJ160
362	345	1300	PMJ180

2 Shield Break Option

Description	Code
With Shield Break	B
Without Shield Break	N

3 Conductor Size (See Application Range Chart)

SIZE mm ²	Code	kcmil	Code
400	400M	750	750K
500	500M	1000	1000K
630	630M	1250	1200K
800	800M	1500	1500K
1000	1000M	1750	1750K
1200	1200M	2000	2000K
1400	1400M	2500	2500K
1600	1600M	3000	3000K
1800	1800M	5000	5000K
2000	2000M		
2500	2500M		

EXAMPLE 1:

PMJ140-B-630MC-CF-X

Premolded joint, 145kV (138kV), with shield break 630mm² copper conductor cable. Kit is supplied with copper housing with compound and fiberglass enclosure with compound. Mechanical shrink installation method.

EXAMPLE 2:

PMJ160-N-2500KA-X-S

Premolded joint, 245kV (230kV), without shield break for 2500 kcmil aluminum conductor cable. Slip-On installation method.

4 Conductor Material

Material	Code
Copper	C
Aluminum	A

5 Additional Housing Protection

Description	Code
None	X
Copper Housing with Compound	C

6 Installation Method

Description	Code
Mechanical Shrink - Not available in 345kV	X
Slip On- Use for spares or long term storage. Installation tool is available and is ordered separately	S

Ship Weight

Catalog Prefix	Approximate Ship Weight
PMJ119	75 kg (165 lbs)
PMJ140	105 kg (266 lbs)
PMJ150	110 kg (243 lbs)
PMJ160	150 kg (331 lbs)
PMJ180	450 kg (992 lbs)

Application Photos

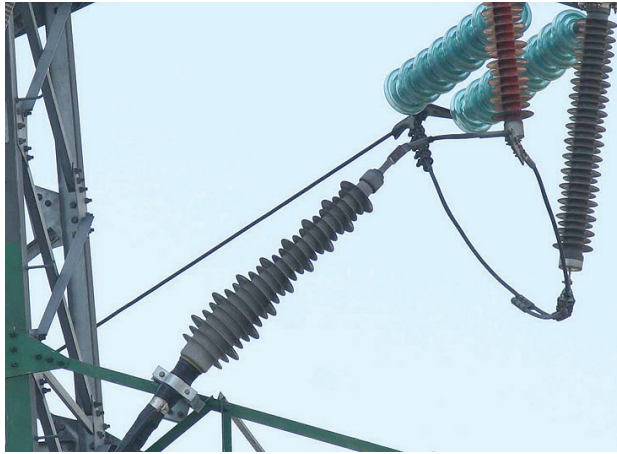

Dry type outdoor termination angle mounted on a tower.

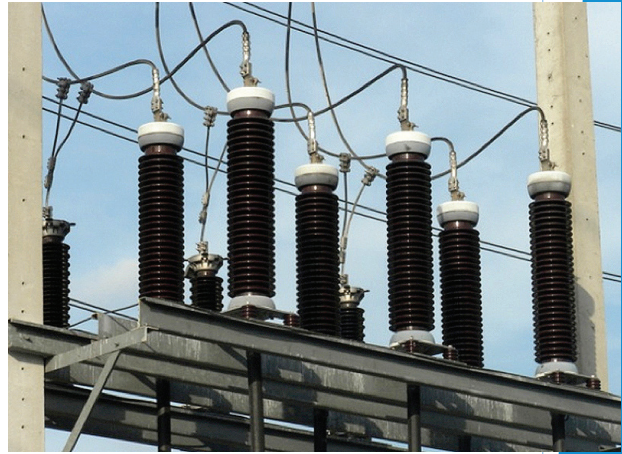

Outdoor terminations with optional brown porcelain.



SSC140-SF terminations installed in a GIS.



Dry type outdoor termination in a substation application.

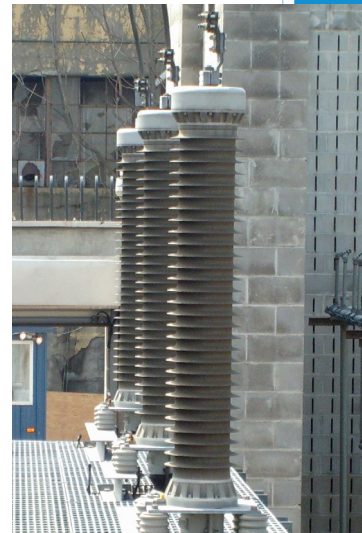

Outdoor termination.



PATR140-SF terminations installed in a GIS.

Contact us today

+1.708.388.5010 or info@gwelec.com



Since 1905, G&W Electric has been a leading provider of innovative power grid solutions, including the latest in load and fault interrupting switches, reclosers, system protection equipment, power grid automation and transmission and distribution cable terminations, joints and other cable accessories. G&W Electric is headquartered in Bolingbrook, Illinois, U.S.A., with manufacturing facilities and sales support in more than 100 countries, including Canada, Italy, China, Mexico, Brazil, India, UAE and Singapore. We help our customers meet their challenges and gain a competitive edge through a suite of advanced products and technical services.