

Cone check valve S4



General:

- Material: PVC-U / PP / PVDF
- Sealing material: EPDM / FPM
- Spring: WST 1.4401
PTFE coated
- Dimensions: DN10 – DN80
d16 – d110
3/8" – 4"

Connector types:

PVC

- Solvent socket DIN / ASTM / JIS
- Solvent spigot DIN
- Threaded socket BSP
- PE fusion socket DIN
- PE fusion spigot DIN
- Fixed flange DIN / ANSI / JIS
- Backing flange DIN
(on request)

PP

- Fusion socket DIN
- Fusion spigot DIN
- Threaded socket BSP

PVDF

- Fusion socket DIN
- Fusion spigot DIN
- Threaded socket BSP

Further Connector types on request

Operating pressure:

DN10 d16 3/8" – DN50 d63 d2"	PN16/10
DN65 d75 d2 1/2"	PN16/8
DN80 d90 3"	PN10/6
DN80 d110 4"	PN6

Technical features:

- Corrosion resistant
- Maintenance free operation over a long working life
- Easy of servicing
- Radial installation or removal
- Quick and exact closing and opening
- Opening pressure 0,06 bar

Diese Druckschrift enthält keine Gewährleistungszusagen, sondern will lediglich eine erste Information vermitteln. Das Programm wird ständig erweitert, daher entsprechen die Ausführungen und Typen dem Stand bei Drucklegung.
Technische Änderungen vorbehalten!

Cone check valve S4

Dimensions:

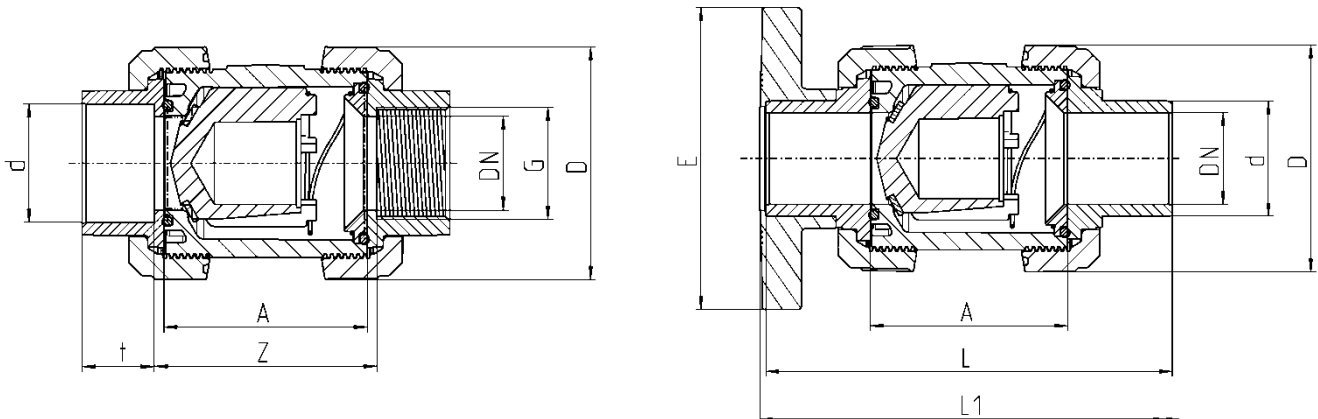

PVC-U

Connector types

PV-U solvent socket / solvent spigot / threaded socket

PVC-U fixed flange

PE fusion socket / fusion spigot

DN	10	15	20	25	32	40	50	65	80	80
d	16	20	25	32	40	50	63	75	90	110
G ¹ TSO	3/8"	1/2"	3/4"	1"	1 1/4"	1 1/2"	2"	2 1/2"	3"	-
A	62	62	70	74	84	95	109	137	163	163
D	53	53	63	70	85	101	124,5	155	188	188
t ² SSO	16,5	16,5	19,5	22,5	26,5	31,5	38,5	45	55,5	64
t ⁴ FSO PE	14,5	16	17	19,5	22	25	29	34,5	37,5	41,5
E ⁶ FF	-	97	105	125	140	150	165	185	200	229
L ⁴ SSP	115	125	145	154	174	194	223	287	300	341
L ⁵ FSP PE	112	123	143	151	142	180	197	253	293	323
L1 ⁶ FF	120	130	150	160	180	200	230	290	310	350
Z ² SSO	68	67	76	80	81	103	120	148	180	173
Z ¹ TSO	67	67	77	81	90	104	120	150	185	-
Z ³ FSO PE	71	68	80	79	98	115	137	165	210	210
PN	16	16	16	16	16	16	16	16	10	6

Dimensions in mm

¹ TSO = threaded socket

² SSO = solvent socket

³ SSP = solvent spigot

⁴ FSO = fusion socket

⁵ FSP = fusion spigot

⁶ FF = fixed flange

- = not realised

Cone check valve S4

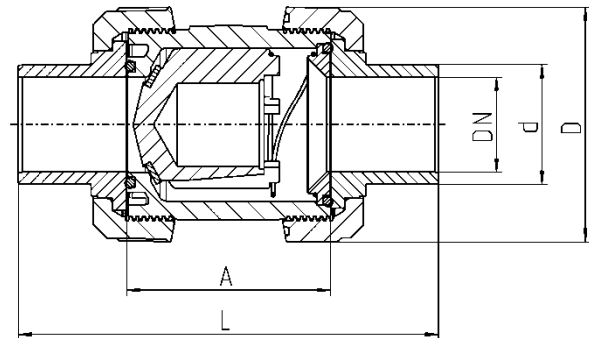
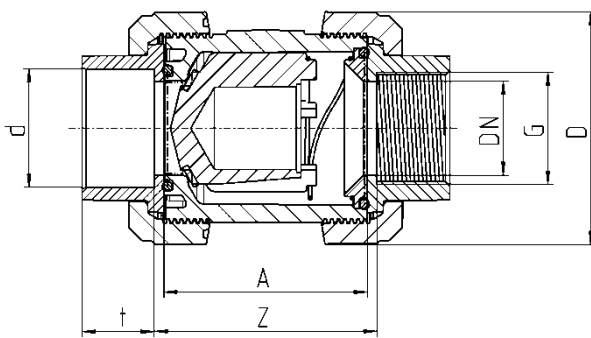

PP

Connector types

PP fusion socket / fusion spigot / threaded socket

PE fusion socket / fusion spigot

DN	10	15	20	25	32	40	50	65	80	80
d	16	20	25	32	40	50	63	75	90	110
G ¹ TSO	3/8"	1/2"	3/4"	1"	1 1/4"	1 1/2"	2"	2 1/2"	3"	-
A	62	62	69	73	83	94	108	133	160	160
D	53	53	64	71	84,5	100	120,5	155	187	187
t ² FSO PP	14,5	16	17,5	19,5	22	25,5	29	34,5	38,5	42
t ² FSO PE	14,5	16	17	19,5	22	25	29	34,5	37,5	41,5
L ³ FSP PP	114	124	143	152	171	191	220	277	295	312
L ³ FSP PE	112	123	142	150	141	179	196	249	290	320
Z ¹ TSO	67	67	74	80	89	103	119	143	180	-
Z ² FSO PP	71	68	78	84	97	113	136	162	211	211
Z ² FSO PE	71	68	79	84	97	114	136	161	207	207
PN	10	10	10	10	10	10	10	8	6	6

Dimensions in mm

¹ TSO = threaded socket

² FSO = fusion socket

³ FSP = fusion spigot

- = not realised



www.fluidflo.com.au

info@fluidflo.com.au

Tel: (03) 9290-9813

ABN 28480253276

Cone check valve S4

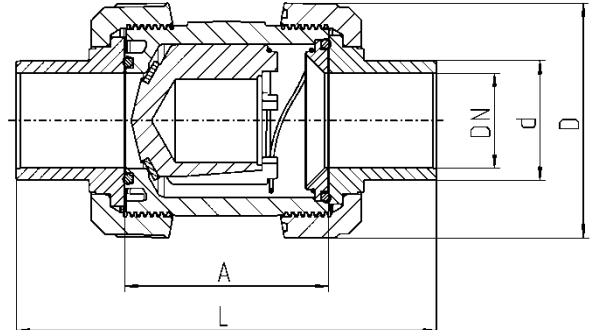
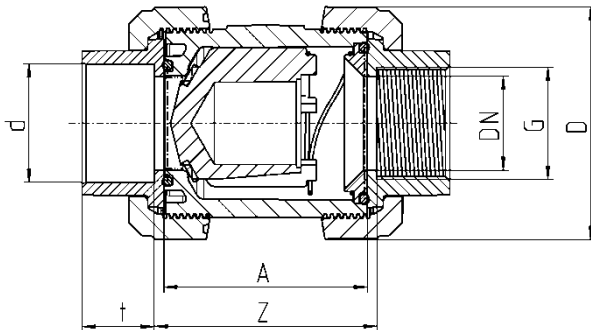

PVDF

Connector types

PVDF fusion socket / fusion spigot / threaded socket

DN	10	15	20	25	32	40	50	65	80	80
d	16	20	25	32	40	50	63	75	90	110
G ¹ TSO	3/8"	1/2"	3/4"	1"	1 1/4"	1 1/2"	2"	2 1/2"	3"	-
A	62	62	69	73	83	94	108	133	160	160
D	52,5	52,5	63	70	83	98,5	118	151	183	183
t ² FSO	14,5	16	17,5	19,5	22	25,5	29	34,5	38,5	41,5
L ³ FSP	114	125	143	152	171	191	220	297	295	320
Z ¹ TSO	67	67	74	80	89	103	119	143	180	-
Z ² FSO	71	68	78	84	97	113	136	162	207	213
PN	16	16	16	16	16	16	16	16	10	6

Dimensions in mm

- ¹ TSO = threaded socket
- ² FSO = fusion socket
- ³ FSP = fusion spigot
- = currently not realised



Cone check valve S4

Exploded drawing:

- 01. O-Ring
- 02. Body
- 03. Flat gasket
- 04. Cone
- 05. Spring (PTFE (Teflon®) coated or WST 1.4401)
- 06. Thrust collar
- 07. O-Ring
- 08. Connector types
 - Solvent socket / -spigot
 - Fusion socket /-spigot
 - Threaded socket
- 09. Union nut
- 11. Screen (only PP and PVDF)
- 13. Flange adapter / stub flange
- 14. Backing flange / fixed flange
- 15. Connection set

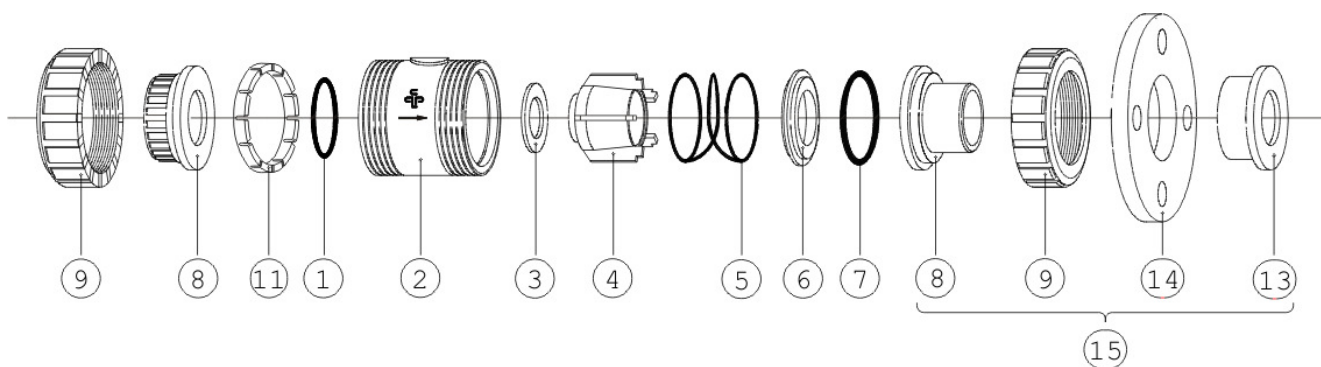

Cone check valve S4



Diagrams:

Pressure loss diagram

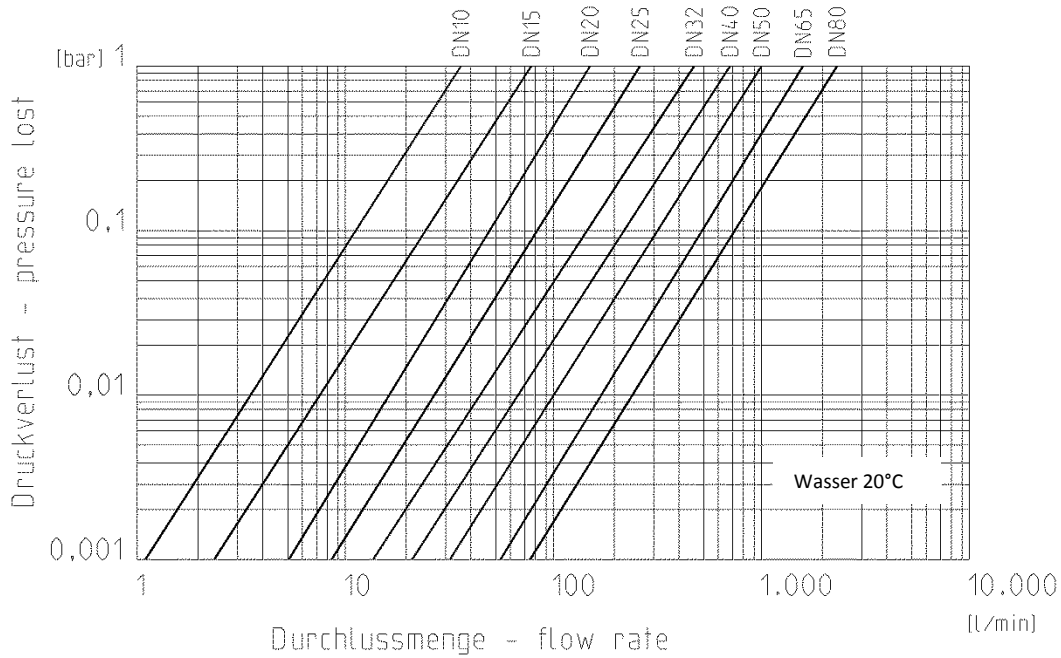

Druckverlust	DN10	DN15	DN20	DN25	DN32	DN40	DN50	DN65	DN80
0,001 bar	1,2	2,4	5	8,4	14,5	21,5	31,6	53,1	74,9
1 bar	36	76	160	265	460	680	1000	1680	2370



Cone check valve S4



Pressure - Temperature-Diagram

PVC-U

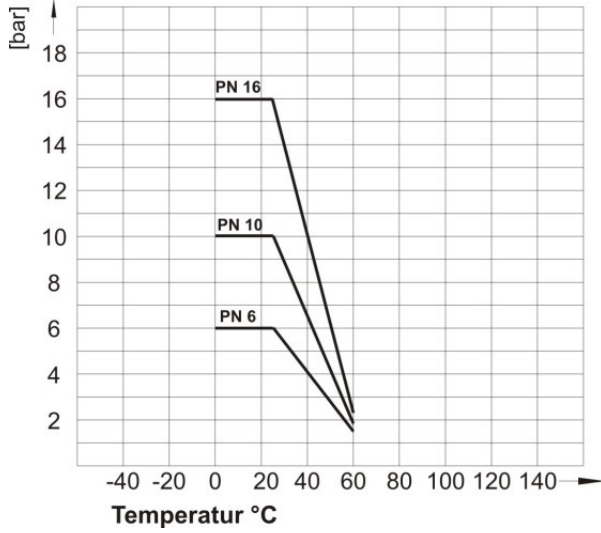

PP

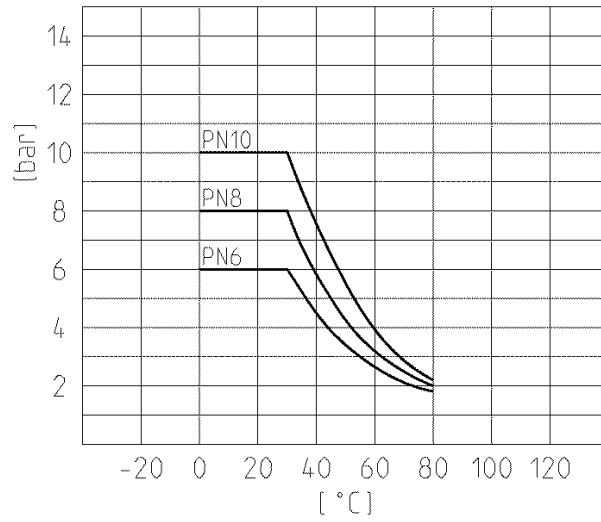

PVDF

