

# MT Series Solenoid Valves

TEL (03) 9290 9813  
INFO@FLUIDFLO.COM.AU  
WWW.FLUIDFLO.COM.AU



## Specifications

Temperature Range:	-25°C to +80°C
Actuation Frequency:	5 cycle/sec
Orifice Area:	19.63 (CV=1.10)
Port Size:	¼" BSP
Weather Rating:	IP65 (min)
Insulated Voltage:	1000v
Duty factor:	100%ED

The MT series of solenoid valves are manufactured to latest technology and give trouble free operation in excess of 1 million cycles. All have threaded ports for independent or Namur interface and are suitable for 5/2 or 3/2 operation.

## Options

- All grade 316 stainless steel version.
- Coils in class I, Div. 1&2, Group A, B, C and D, Exd IICT6, Ex ia CT6 and Ex m II T6.
- Coatings in PTFE or Nickel Phosphorus.
- Temperatures from -40 to +200 deg C available.
- Glass filled Nylon or Anodized aluminium body.
- Double coil version available.

## APPROVALS



## Features

- 5/2 or 3/2 configuration with reversible mount plate.
- Manual override.
- Interchangeable multi voltage coil.
- Stainless-steel fasteners included.
- LED plug for power on indication.
- Interchangeable DIN plug.
- Coils in class I, Div. 1&2, Group A, B, C and D, Exd IICT6, Ex ia CT6 and Ex m II T6.
- Anodized body for superior protection.

# MT Series Solenoid Valves

TEL (03) 9290 9813  
 INFO@FLUIDFLO.COM.AU  
 WWW.FLUIDFLO.COM.AU



## Operation

FIG. 1

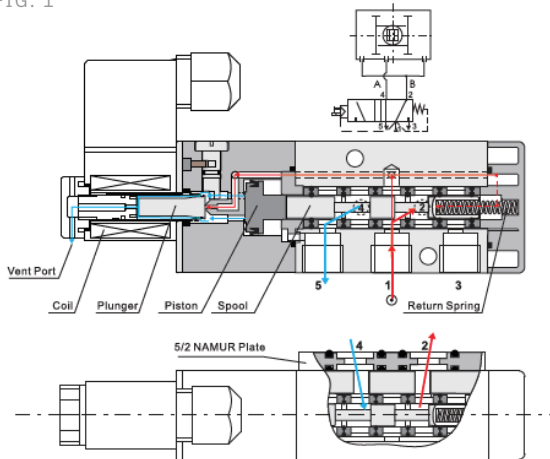

In Fig.1, the coil is de-energized, a spring on the plunger will return the plunger to its seat, blocking internal pilot air, and opens a vent port. This vent port will allow the air on the piston to escape, and the return spring will return the spool to its normal position. In this position, the spool directs flow of supply air from inlet port 1 to outlet port 4 while outlet port 2 is connected to exhaust port 3. As for the standard assembly, the outlet port 4 is connected to port B of actuator. The air from outlet port 4 will return the piston of actuator to closed position.

FIG. 2

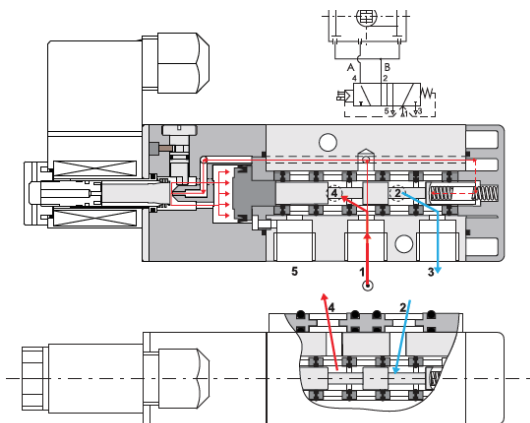

In Fig. 2, when the coil is energized it creates a magnetic field surrounding the plunger assembly and plunger. The plunger is lifted off its seat by this force and supply air provides an internal pressure that is directed to the piston which shifts the spool and compresses the return spring. This shifting directs the flow of supply air from inlet port 1 to outlet port 2 while outlet port 4 is connected to exhaust port 5. The spool assembly now connects port 2 with port A of actuator. The air from outlet 2 will move the pistons of actuator to the opening position when coil is energized.

## MT510F3 Dimensions

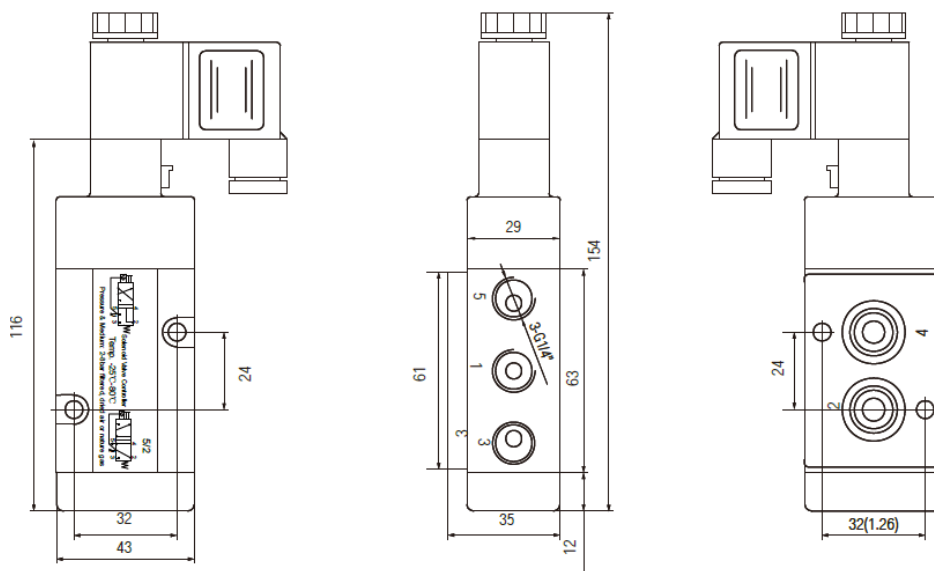







# MT Series Solenoid Valves

TEL (03) 9290 9813  
 INFO@FLUIDFLO.COM.AU  
 WWW.FLUIDFLO.COM.AU

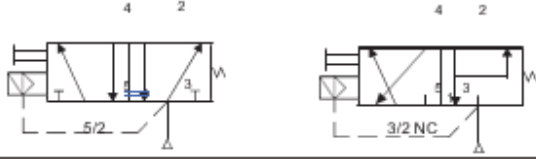

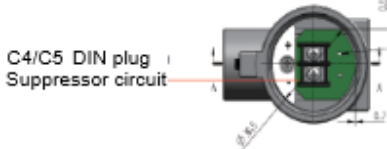
## Coil Specifications & Options

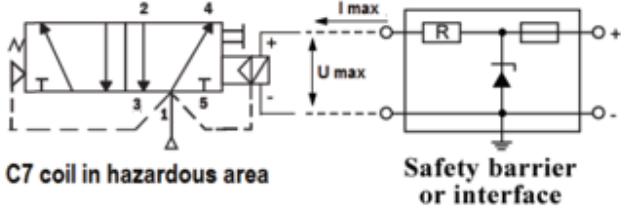
Item of Spool Valve	MT510F3	Coil Code	C4 & C5 (flameproof)	C7 (intrinsically safe)
Spool valve/Body	Extruded aluminum	Operating Voltage	12/24/48VDC-4W	24VDC
Coating	Anodized coated, or Nickel coated		110/210/220/240VAC-4VA (50/60HZ)	
Seal	Buna N	Voltage Tolerance	±10%	
Function	5/2 and 3/2NC, CV = 1.1(19.63mm <sup>2</sup> ) Monostable	Cable Entry	M20 1.5 or 1/2" NPT, terminal strip	
Materials in contact with fluid	Aluminum, Glass-filled PA, POM, Buna N	Insulation Protection	F Class	H Class
Supply Ports	1/4" BSPP or NPT	Insulated voltage	1000V	
Assembly and Connection	24×32 Namur, Manual override on body	Duty factor	100% ED	
Fasteners	Stainless steel	Weatherproof	IP67	
Environment	Indoor and outdoor	Area Classification	Ex d IIC T6	Ex ia IIB T6 Ga
Medium Temperature	-25°C~80°C	Zone	Class1 Zone1A	Class 1 Zone 0
Working Pressure	2~8 bar	Operating Temp.	-20°C~60°C	-40°C~60°C
Working Medium	less than 40µm filtered and dried air	<b>APPROVED BY</b>		
Bi-stable (MT520F3C4/C5)	available on requiring	C0	CE IP67 NAME4,4X	C7
Working life	more than 1000,000 cycle (On the normal working condition)		CE Ex ATEX IP67	
<b>Coil Type</b>		<b>Function</b>		
C0	 C0 with fieldbus 			
C4	 C5 (316ss) 			
C7		<p>**Refer to below drawing, C7 coil must be connected individually to an approved safety barrier. Placed in a safe zone, these safety barriers can be used to supply intrinsically safe coil C7 installed in a hazardous zone. The electrical connection between the safety barrier (or interface) and the intrinsically safe coil C7 can be made using ordinary wires or cables. The inductance of the connecting line between the safety barrier and the pilot coil C7 must be less than 0.5mH</p> 		

Each 5/2 solenoid valve comes with a 5/2 and a 3/2 interface plate for double acting and spring return actuators.

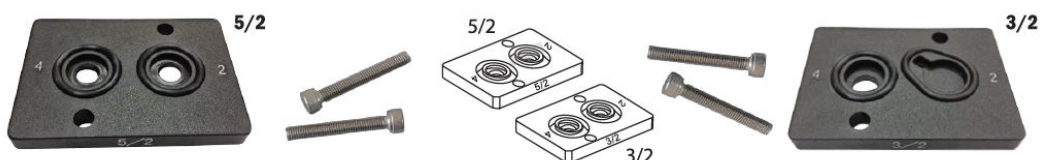

# MT Series Solenoid Valves

TEL (03) 9290 9813  
 INFO@FLUIDFLO.COM.AU  
 WWW.FLUIDFLO.COM.AU



## Coil Specifications & Options

	Model	Size	
Brass cone	BM10	BSP or NPT1/8"	
	BM11	BSP or NPT1/4"	
	BM12	BSP or NPT3/8"	
	BM13	BSP or NPT1/2"	
	BM20	BSP or NPT1/8"	
Brass Flat	BM21	BSP or NPT 1/4"	
	BM22	BSP or NPT3/8"	
	BM23	BSP OR NPT 1/2"	
	SM20	BSP or NPT1/8"	
Stainless steel flat	SM21	BSP or NPT1/4"	
	SM22	BSP or NPT3/8"	
	SM23	BSP or NPT1/2"	
	PM30	BSP or NPT1/8"	
Plastic cone	PM31	BSP or NPT1/4"	
	PM32	BSP or NPT3/8"	
	PM33	BSP or NPT1/2"	
	BM40	BSP or NPT1/8"	
Brass speed control	BM41	BSP or NPT1/4"	
	BM42	BSP or NPT3/8"	
	BM43	BSP or NPT1/2"	
	BM50	BSP or NPT1/8"	
Brass speed control/filter	BM51	BSP or NPT1/4"	
	BM52	BSP or NPT3/8"	
	BM53	BSP or NPT1/2"	

Armed speed controllers are available for both double acting (ASCD) and spring return (ASCSR) for precise control of opening and closing speeds of actuators. Open and close speeds can be controlled independently or simultaneously.

