

LEGEND ATTACHMENTS

2020
Product Catalog



☎ 218-844-5378 (Main Office)
☎ 612-360-4160 (Tim Lake - Sales)
✉ tlake@legendattachments.com
www.LegendAttachments.com

📍
Legend Attachments
1090 Legion Road
Detroit Lakes, MN 56501

GRAPPLES

Standard Rock Grapple.....	1
Heavy Duty Rock Grapple.....	1
Utility Grapple.....	2
Compact Tractor Brush Grapple.....	2
Heavy Duty Low Profile Bucket with Grapple.....	3
Stump Grapple.....	3
Grapple Rake.....	4
Dual Arm Grapple Rake.....	4
Bale Grapple.....	5
High Capacity Bucket Grapple.....	5
Standard Manure Grapple.....	6
Root Grapple.....	6
Heavy Duty Low Profile Scrap Grapple.....	7
Heavy Duty Round Tine Grapple.....	7

BRUSH CUTTERS

Rotary Brush Cutter Direct Std Flow.....	9
Rotary Brush Cutter Gear Box Std Flow.....	10
Rotary Brush Cutter High Flow.....	11
Open Front Rotary Brush Cutter Direct Std Flow.....	12
Open Front Rotary Brush Cutter Gear Box Std Flow.....	13
Open Front Rotary Brush Cutter High Flow.....	14

BUCKETS

Utility Rock Bucket/Skeleton.....	15
Standard Rock Bucket/Skeleton.....	15
Heavy Duty Rock Bucket/Skeleton.....	16
Heavy Duty Rock Bucket 5' Spacing.....	16
Heavy Duty Low Profile Bucket.....	17
Tooth Bucket.....	17
Utility Bucket.....	18
Stump Bucket.....	18
Manure Bucket.....	19

LANDSCAPING

Tree Spade.....	21
Rock Digger.....	21
Tree Puller - Low Profile.....	22
Tree Puller - HD.....	22
Log Fork.....	23
Tree Shear.....	24
Land Plane.....	24
Log Splitter.....	25

PALLET FORKS

Standard Duty Pallet Forks.....	27
Heavy Duty Pallet Forks.....	28
Heavy Duty Walk-Thru Pallet Forks.....	28
Heavy Duty 6' Wide Pallet Forks.....	29
Clamp-On Pallet Forks.....	30
Pallet Fork Clamp On Trailer Mover.....	31

SNOW REMOVAL

Snow Bucket.....	33
Screen Snow Bucket.....	33
Snow Pusher.....	34
Snow Pusher Accessories.....	34
Bucket Mount Snow Pusher.....	35

HAY HANDLING

Receiver Style Bale Spear.....	37
Single Bale Spear (Econo).....	37
Single Bale Spear.....	37
Double Bale Spear.....	38
Triple Bale Spear.....	38
Double Round Bale Spear.....	38
Square/Round Bale Spear Combo.....	39
Heavy Duty Pallet Fork/Bale Spear Combo.....	40
Bale Accumulator Grapple.....	41
6 Pack Bale Accumulator Grapple.....	42

3 POINT

3 Point Trailer Hitch.....	43
Category 1 - 3 Point Landscape Rake.....	44

MOUNTING PLATES

U-Style Mounting Plates.....	45
V-Style Mounting Plates.....	45
Solid Style Mounting Plates.....	45
2 Piece Mounting Plates.....	45
Miscellaneous Mounting Plates.....	46-47

3 POINT ADAPTER

3 Point Adapter.....	49
----------------------	----

UNIVERSAL ADAPTER

Universal Quick Attach Adapter.....	50
-------------------------------------	----

RECEIVER PLATES

Receiver Plates.....	51
Receiver Plate Accessories.....	51

ACCESSORIES

Bolt-On Cutting Edge.....	53
Bolt-On Tooth Bar.....	53

STANDARD ROCK GRAPPLE

72" Model #33011 • 79" Model #33167
82" Model #33224

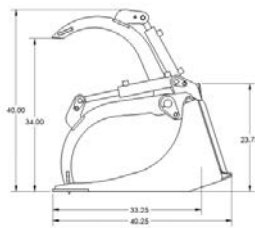

- Integrated step in the center of the attachment allows for easy, slip free entry into your skid loader while providing superior hose connection protection. Raised ridge in center of tines & profiled rear help secure rocks while digging.
- Independent grapples with greasable main pins and bushings.
- Engineered for loading rock, sifting debris from dirt or sand, general debris removal & more. Dig, grab, pull, clear & sift with one attachment.
- Heavy duty skeleton frame of the bucket provides the durability to meet the most demanding jobs and toughest conditions. Serrated tooth cross bar design holds the toughest materials.

HEAVY DUTY ROCK GRAPPLE

72" Model #33004 • 79" Model #33215
82" Model #33216

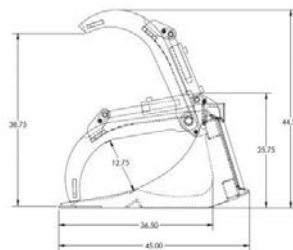

- Integrated step in the center of the attachment allows for easy, slip free entry into your skid loader while providing superior hose connection protection. Raised ridge in center of tines & profiled rear help secure rocks while digging.
- Independent grapples with greasable main pins and bushings.
- Engineered for loading rock, sifting debris from dirt or sand, general debris removal & more. Dig, grab, pull, clear & sift with one attachment.
- Heavy duty skeleton frame of the bucket provides the durability to meet the most demanding jobs and toughest conditions. Serrated tooth cross bar design holds the toughest materials.

SPECIFICATIONS

Width	72", 79", 82"
Overall Height - Closed	27"
Overall Height - Open	40"
Overall Depth	41.25"
Grapple Opening	34"
Depth of Bucket	33.25"
Tines	3/8" - Grade 50
Cutting Edge	1/2" x 8" - Grade 50
Top Tube	3" x 4" x 1/4"
Bottom Tube	2" x 4" x 1/4"
Grapple Arms	1/2" Grade 50 - Laser Cut
Cylinders	2" x 8" - Welded
Hydraulic Couplers	Flat Face
Hydraulic Hoses	3/8"
Max. PSI	3000 PSI
Pivot Points	Grease Zerk
Main Pin	1.75" x 20"
Rear Cylinder Pin	1" x 6"
Front Cylinder Pin	1" x 5.5"
Weight	72" = 900 lbs, 79" = 987 lbs, 82" = 1025 lbs

SPECIFICATIONS

Width	72", 79", 82"
Overall Height - Closed	27"
Overall Height - Open	44"
Overall Depth	46"
Grapple Opening	38"
Depth of Bucket	37"
Tines	3/8" - Grade 50
Cutting Edge	1/2" x 10" - Grade 50
Top Tube	3" x 4" x 1/4"
Bottom Tube	3" x 4" x 1/4"
Grapple Arms	1/2" Grade 50 - Laser Cut
Cylinders	2 1/2" x 8" - Welded
Hydraulic Couplers	Flat Face
Hydraulic Hoses	3/8"
Max. PSI	3000 PSI
Pivot Points	Grease Zerk
Main Pin	1.75" x 20"
Rear Cylinder Pin	1" x 6"
Front Cylinder Pin	1" x 5.5"
Weight	72" = 1100 lbs, 79" = 1264 lbs, 82" = 1312 lbs

GRAPPLES

UTILITY GRAPPLE

72" Model #23001

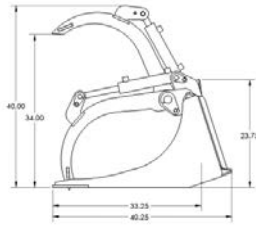

- Engineered for loading rock, sifting debris from dirt or sand, general debris removal and more. Dig, grab, pull, clear and sift with one attachment.
- Heavy duty skeleton frame of the bucket provides the durability to meet the most demanding jobs and toughest conditions.
- Integrated step in the center of the attachment allows for easy, slip free entry into your skid loader while providing superior hose connection protection.
- Raised ridge in center of tines and profiled rear help secure rocks while digging.

SPECIFICATIONS

Width	72"
Overall Height - Closed	26"
Overall Height - Open	40"
Overall Depth	41.75"
Grapple Opening	34"
Depth of Bucket	35.25"
Spacing Between Tines	3"
Cutting Edge	1/2" x 8" - Grade 50
Top Tube	3" x 3" x 3/16"
Bottom Tube	3" x 3" x 3/16"
Grapple Arms	3/8" Grade 50
Cylinders	2" x 8" - Clevis
Hydraulic Couplers	Optional
Hydraulic Hoses	3/8"
Max. PSI	2500 PSI
Weight	72" = 783 lbs

**Recommended for loaders up to
2250 lb total lift capacity**

COMPACT TRACTOR BRUSH GRAPPLE

60" Model #33132 • 72" Model #33126

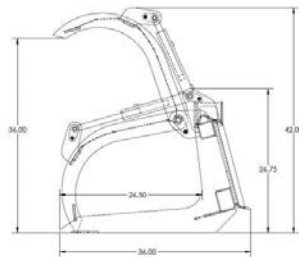

- Gusseted between teeth for added strength
- Handle uneven, odd-shaped material
- Designed to be light but strong so tractor owners can use their tractor to its full potential

SPECIFICATIONS

Width	60", 72"
Overall Height - Closed	26.75"
Overall Height - Open	42"
Overall Depth	36"
Grapple Opening	36"
Depth of Bucket	26.5"
Tines	5/16" - Grade 50
Spacing Between Tines	60" = 9.5", 72" = 8.5"
Top Tube	3" x 3" x 3/16"
Bottom Tube	3" x 4" x 3/16"
Grapple Arms	1/4" A-36
Cylinders	1 1/2" x 8" - Welded
Hydraulic Couplers	Not Included
Hydraulic Hoses	3/8"
Max. PSI	3000 PSI
Pivot Points	Grease Zerks
Main Pin	1" x 20"
Cylinder Pins	1" x 5 1/2"
Weight	60" = 465 lbs, 72" = 497 lbs

**Recommended for loaders up to
1500 lb total lift capacity**

HEAVY DUTY LOW PROFILE BUCKET W/ GRAPPLE

60" Model #33270 • 68" Model #33271 • 72" Model #33267
78" Model #33272 • 80" Model #33273 • 84" Model #33274
Also Available with Teeth

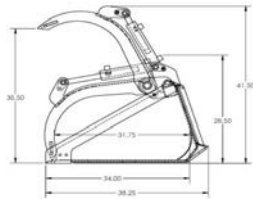

- Low profile for better visibility of the cutting edge
- Excellent for all your landscaping or demolition duties
- Reinforced bucket liner for longer life and less buckling

STUMP GRAPPLE

Model #33032

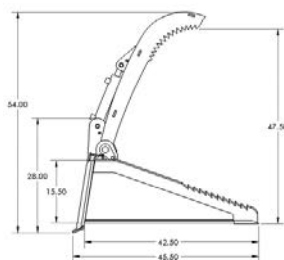

- The Stump Bucket is a powerful tool for the fast and effective removal of stumps and roots. Dig out the stump, pop it out of the ground, and haul it away. Handle brush, logs, debris and other materials securely with this sturdy grapple.
- Perfect for grounds maintenance, landscaping, tree nurseries and forestry industries. Rip, Tear and Shred Stubborn Root Balls, Stumps, and Tree Debris from the Ground. Optional weld on teeth.

SPECIFICATIONS

Width	60", 68", 72", 78", 80" & 84"
Overall Height - Closed	28.5"
Overall Height - Open	41.5"
Overall Depth	38.25"
Grapple Opening	35.5"
Depth of Bucket	34"
Main Body Thickness	3/16"
Side Cutting Edge	3/8" - Grade 50
Wear Bars	1/2" Grade 50 - 10" Wide
Mounting Plate	5/16" HR Steel
Cutting Edge	3/4" x 6"
Grapple Arms	1/2" Grade 50 - Laser Cut
Cylinders	2" x 8" - Welded
Hydraulic Couplers	Flat Face
Hydraulic Hoses	3/8"
Max. PSI	3000 PSI
Struck Capacity cu. ft.	60" - 13.2, 68" - 15, 72" - 15.9 78" - 17.5, 80" - 17.75, 84" - 18.5
Heaped Capacity cu. ft.	60" - 15.8, 68" - 18, 72" - 19 78" - 20.5, 80" - 20.12, 84" - 22.25
Weight	60" - 827 lbs, 68" - 867 lbs 72" - 872 lbs, 78" - 917 lbs 80" - 952 lbs, 84" - 972 lbs

SPECIFICATIONS

Width	45"
Overall Height - Closed	28.25"
Overall Height - Open	47"
Overall Depth	46"
Grapple Opening	45.5"
Depth of Bucket	45.5"
Side Cutting Edge	1/2" - Grade 50
Wear Bars	1/2" - Grade 50
Top Tube	3" x 4" x 1/4"
Bottom Tube	2" x 4" x 1/4"
Grapple Arms	1/2" Grade 50 - Laser Cut
Tines	3/8" Grade 50 - Laser Cut
Cylinders	2 1/2" x 8" - Welded Cross Tube
Main Pin	1.50" Diameter - Greasable
Hydraulic Couplers	Flat Face
Hydraulic Hoses	3/8"
Max. PSI	3000 PSI
Weight	500 lbs

GRAPPLES

GRAPPLE RAKE

72" Model #33078

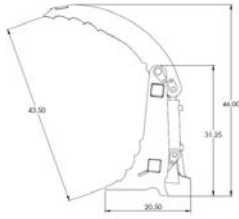

- Independent Grapple Arms for grabbing uneven loads
- Serrated tooth design grabs and holds tight

SPECIFICATIONS

Overall Width	70.5"
Overall Height - Closed	31.25"
Overall Height - Open	46"
Overall Depth	20.5"
Grapple Opening	43.5"
Depth of Bucket	35.25"
Tines	1/2" - Grade 50
Spacing Between Tines	9 1/2"
Tubes	3" x 3" x 1/4"
Grapple Arms	1/2" Grade 50 - Laser Cut
Cylinders	2 1/2" x 8" - Welded Cross Tube
Hydraulic Couplers	Flat Face
Hydraulic Hoses	3/8"
Max. PSI	3000 PSI
Pivot Points	Grease Zerks
Weight	830 lbs

DUAL ARM GRAPPLE RAKE

72" Model #33220 • 78" Model #33221

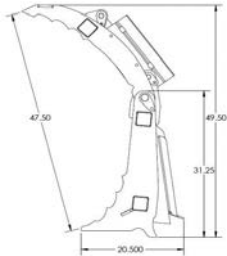

- Easily pick up debris
- Ability to use as a root rake
- Great for raking, piling, storm clean-up and demolition
- Excellent for rake or back dragging

SPECIFICATIONS

Overall Width	72", 78"
Overall Height - Closed	31.25"
Overall Height - Open	49.5"
Overall Depth	20.5"
Grapple Opening	47.5"
Tines	1/2" - Grade 50
Spacing Between Tines	9 1/2"
Tubes	3" x 3" x 1/4"
Grapple Arms	1/2" Grade 50 - Laser Cut
Cylinders	2 1/2" x 8" - Welded Cross Tube
Hydraulic Couplers	Flat Face
Hydraulic Hoses	3/8"
Max. PSI	3000 PSI
Pivot Points	Grease Zerks
Weight	72" = 865 lbs, 78" = 950 lbs

BALE GRAPPLE

72" Model #33225 • 79" Model #33226 • 82" Model #33227

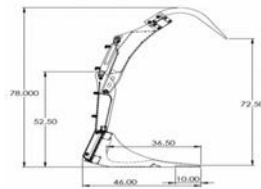

- Easily lift 2 large bales at once
- Open bottom lets the debris fall through
- Large jaw opening for handling round bales
- Curved jaw teeth penetrate the bale, minimizing damage

SPECIFICATIONS

Width	72", 79", 82"
Overall Height - Closed	55"
Overall Height - Open	78"
Overall Depth	60"
Grapple Opening	73"
Depth of Bucket	40"
Tines	3/8" - Grade 50
Spacing Between Tines	5"
Cutting Edge	1/2" x 10" - Grade 50
Top Tube	3" x 4" x 1/4"
Bottom Tube	3" x 4" x 1/4"
Grapple Tines	5/8" T-1 - Laser Cut
Cylinders	2" x 12" - Welded Clevis
Hydraulic Couplers	Flat Face
Hydraulic Hoses	3/8"
Max. PSI	3000 PSI
Pivot Points	Grease Zerks
Weight	72" - 1204 lbs, 79" - 1289 lbs 82" - 1342 lbs

HIGH CAPACITY BUCKET GRAPPLE

84" Model #33337

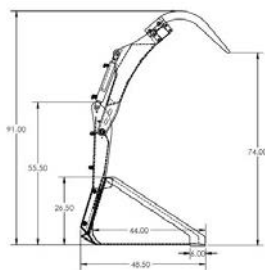

- Easily lift 2 large bales at once
- Open bottom lets the debris fall through
- Large jaw opening for handling round bales
- Curved jaw teeth penetrate the bale, minimizing damage

SPECIFICATIONS

Width	84"
Overall Height - Closed	55"
Overall Height - Open	78"
Overall Depth	60"
Grapple Opening	73"
Depth of Bucket	40"
Tines	3/8" - Grade 50
Cutting Edge	1/2" x 10" - Grade 50
Top Tube	3" x 4" x 1/4"
Bottom Tube	3" x 4" x 1/4"
Grapple Tines	5/8" T-1 - Laser Cut
Cylinders	2" x 12" - Welded Clevis
Hydraulic Couplers	Flat Face
Hydraulic Hoses	3/8"
Max. PSI	3000 PSI
Pivot Points	Grease Zerks
Struck Capacity cu. ft.	27.3
Heaped Capacity cu. ft.	32.7
Weight	1229 lbs

GRAPPLES

STANDARD MANURE GRAPPLE

66" Model #33192 • 72" Model #33246

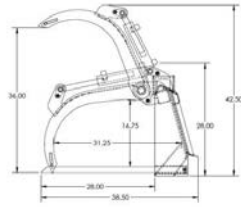

- Independent grapples with greaseable main pin
- Excellent for many different materials including manure, brush, hay, straw and light demolition
- Replaceable tines constructed of 1.5" 1144 stress relieved steel, Ultimate Tensile Strength of 115,000 psi

SPECIFICATIONS

Width	66" & 72"
Overall Height - Closed	28"
Overall Height - Open	42.5"
Overall Depth	38.5"
Grapple Opening	36"
Depth of Bucket	31.25"
Replaceable Tines	1 1/2" - 1144 Steel
Spacing Between Tines	5 1/4"
Main Body	1/4" A36 HRP & O
Grapple Arms	3/8" - Grade 50
Cylinders	2" x 8" - Welded Cross Tube
Hydraulic Couplers	Optional
Hydraulic Hoses	3/8"
Max. PSI	3000 PSI
Pivot Points	Grease Zerks
Weight	66" = 780 lbs, 72" = 809 lbs

ROOT GRAPPLE

73" Model #33081

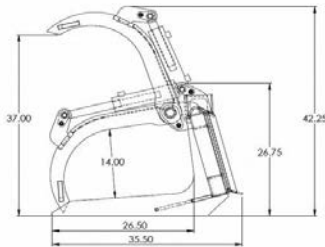

- For the most powerful skid steers with the toughest of jobs
- Move large loads with ease
- Closes tighter than most other Grapples
- Clears large logs, rocks, brush and demolition materials

SPECIFICATIONS

Overall Width	73"
Overall Height - Closed	28"
Overall Height - Open	43"
Overall Depth	36"
Grapple Opening	36"
Bucket Depth	27"
Tines	1" - T-1 High Strength Steel
Spacing Between Tines	11"
Top Tube	3" x 3" x 1/4"
Bottom Tube	3" x 4" x 1/4"
Grapple Arms	3/4" Grade 50 - Laser Cut
Cylinders	2 1/2" Bore
Hydraulic Couplers	Flat Face
Hydraulic Hoses	3/8"
Max. PSI	3000 PSI
Pivot Points	Grease Zerks
Main Point	1.75" x 20"
Rear Cylinder Pin	1" x 6"
Front Cylinder Pin	1" x 5.5"
Weight	1025 lbs

HEAVY DUTY LOW PROFILE SCRAP GRAPPLE

60" Model #33290 • 68" Model #33291 • 72" Model #33292
78" Model #33293 • 80" Model #33294 • 84" Model #33295

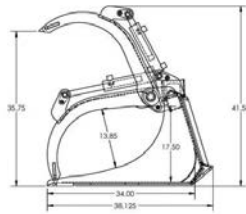

- Low profile for better visibility of the cutting edge
- Excellent for all your landscaping or demolition duties
- Reinforced bucket liner for longer life and less buckling

HEAVY DUTY ROUND TINE GRAPPLE

72" Model #33029 • 84" Model #33366

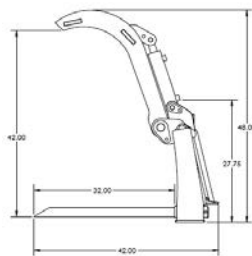
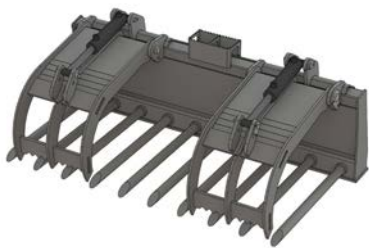

- Independent, dual grapples to handle the toughest of loads
- Designed to pick up brush and debris while leaving the dirt behind

SPECIFICATIONS

Overall Width	60", 68", 72", 78", 80" & 84"
Overall Height - Closed	28.5"
Overall Height - Open	41.5"
Overall Depth	38.125"
Grapple Opening	35.75"
Depth of Bucket	34"
Main Body Thickness	3/16"
Side Plate	3/8" - Grade 50
Wear Bars	1/2" Grade 50 - 10" Wide
Mounting Plate	5/16" - HR Steel
Cutting Edge	3/4" x 6"
Grapple Arms	1/2" Grade 50 - Laser Cut
Cylinders	2" x 8" Welded
Hydraulic Hoses	3/8"
Max. PSI	3000 PSI
Pivot Points	Grease Zerks
Struck Capacity cu. ft.	60" = 13.2, 68" = 15, 72" = 15.9 78" = 17.5, 80" = 17.75, 84" = 18.5
Heaped Capacity cu. ft.	60" = 15.8, 68" = 18, 72" = 19 78" = 20.5, 80" = 20.12, 84" = 22.25
Weight	60" = 842 lbs, 68" = 882 lbs 72" = 897 lbs, 78" = 937 lbs 80" = 980 lbs, 84" = 996 lbs

SPECIFICATIONS

Width	72", 84"
Overall Height - Closed	27"
Overall Height - Open	44"
Overall Depth	42"
Grapple Opening	40"
Depth of Bucket	32.5"
Tines	2" - 1045 Cold Rolled Round
Spacing Between Tines	5 1/4"
Bucket Thickness	3/16", 1/4" & 3/8" Frame Work, Laser Cut
Bottom Plate	1/2" - Grade 50 Steel
Grapple Arms	1/2" Grade 50 Steel - Laser Cut
Cylinders	2 1/2" Bore
Hydraulic Couplers	Flat Face
Hydraulic Hoses	3/8"
Max. PSI	3000 PSI
Pivot Points	Grease Zerks
Main Pin	1.75" x 22"
Rear Cylinder Pin	1" x 6"
Front Cylinder Pin	1" x 5 1/2"
Weight	72" = 1195 lbs, 84" = 1375 lbs

ROTARY BRUSH CUTTER - DIRECT STD FLOW

60" Model #33057 • 66" Model #33092
72" Model #33058 • 78" Model #33083



- Manufactured as one of the toughest Brush Cutters available
- Cut grass or brush up to 3"
- Great for cleaning trails or construction sites
- Painted using a 2 part Urethane process for an exceptional finish

SPECIFICATIONS

Blade Carrier	Laser Cut Plate
Blade Rotation	Counter Clockwise
Cutting Capacity	Up to 3"
Drive	Eskridge
Motor	6.1 cu. in.
Hydraulic Couplers	Flat Face 1/2" Body - ISO16028
Hydraulic Hoses	3/4"
Max. PSI	3000 PSI
Wear Bars	3/8" Thick - Welded on
Front Chain Mount	Replaceable 5/16" chain - 5 links long
Rear Chain Mount	Replaceable 5/16" chain - 3 links long

ADDITIONAL SPECIFICATIONS	60" MODEL #33057	66" MODEL #33092	72" MODEL #33058	78" MODEL #33083
Overall Width	64"	70"	75.5"	85"
Overall Length	74"	82"	88"	96"
Overall Height	24"	24"	24"	24"
Blade, Bolts	Blades: 5/8" x 5" and 2.5" Drop - 19.25" hole to tip Bolts: BB100A	Blades: 5/8" x 5" and 2.5" Drop - 19.25" hole to tip Bolts: BB100A	Blades: 5/8" x 5" and 2.5" Drop - 25.25 hole to tip Bolts: BB100A	Blades: 5/8" x 5" and 2.5" Drop - 25.25 hole to tip Bolts: BB100A
Blade Carrier	3/4" T1, 27" Diameter	3/4" T1, 32" Diameter	3/4" T1, 27" Diameter	3/4" T1, 35 1/4" Diameter
Nut	1.25 - 7" Castle Nut	1.25 - 7" Castle Nut	1.25 - 7" Castle Nut	1.25 - 7" Castle Nut
Flow	15 - 25 GPM	15 - 25 GPM	15 - 25 GPM	15 - 25 GPM
Blade Tip Speed	Min @ 15 GPM (8547 FPM) Max @ 25 GPM (14244 FPM)	Min @ 15 GPM (9587 FPM) Max @ 25 GPM (15978 FPM)	Min @ 15 GPM (8482 FPM) Max @ 25 GPM (14136 FPM)	Min @ 15 GPM (11594 FPM) Max @ 25 GPM (19323 FPM)
Deck Thickness	1/4"	1/4"	1/4"	1/4"
Weight	925 lbs	1095 lbs	1195 lbs	1560 lbs

BRUSH CUTTERS

ROTARY BRUSH CUTTER - GEAR BOX STD FLOW

60" Model #33066 • 66" Model #33091

72" Model #33088 • 78" Model #33089



- Manufactured as one of the toughest Brush Cutters available
- Cut grass or brush up to 2 1/2"
- Great for cleaning trails or construction sites
- Painted using a 2 part Urethane process for an exceptional finish

SPECIFICATIONS

Blade Carrier	Laser Cut Plate
Blade Rotation	Counter Clockwise
Cutting Capacity	Up to 2 1/2"
Drive	Omni Gear Box
Motor	8.6 cu. in.
Hydraulic Couplers	Flat Face 1/2" Body - ISO16028
Hydraulic Hoses	3/4"
Max. PSI	3000 PSI
Wear Bars	3/8" Thick - Welded on
Front Chain Mount	Replaceable 5/16" chain - 5 links long
Rear Chain Mount	Replaceable 5/16" chain - 3 links long

ADDITIONAL SPECIFICATIONS	60" MODEL #33066	66" MODEL #33091	72" MODEL #33088	78" MODEL #33089
Overall Width	64"	70"	75.5"	85"
Overall Length	74"	82"	88"	96"
Overall Height	24"	24"	24"	24"
Blade, Bolts	Blades: 1/2" x 4" and 2.5" Drop - 19.75" hole to tip Bolts: BB10	Blades: 5/8" x 5" and 2.5" Drop - 22.25" hole to tip Bolts: BB10	Blades: 5/8" x 5" and 2.5" Drop - 25.25 hole to tip Bolts: BB10	Blades: 5/8" x 5" and 2.5" Drop - 28.25 hole to tip Bolts: BB10
Blade Carrier	3/4" T1 Plate	3/4" T1 Plate	3/4" T1 Plate	3/4" T1 Plate
Nut	1.125 Fine Thread Top Lock	1.125 Fine Thread Top Lock	1.125 Fine Thread Top Lock	1.125 Fine Thread Top Lock
Flow	15 - 25 GPM	15 - 25 GPM	15 - 25 GPM	15 - 25 GPM
Blade Tip Speed	Min @ 15 GPM (8928 FPM) Max @ 25 GPM (14879 FPM)	Min @ 15 GPM (9928 FPM) Max @ 25 GPM (16549 FPM)	Min @ 15 GPM (10775 FPM) Max @ 25 GPM (17958 FPM)	Min @ 15 GPM (12006 FPM) Max @ 25 GPM (20010 FPM)
Deck Thickness	1/4"	1/4"	1/4"	1/4"
Weight	940 lbs	1110 lbs	1210 lbs	1575 lbs

ROTARY BRUSH CUTTER - HIGH FLOW

60" Model #33085 • 66" Model #33093
72" Model #33086 • 78" Model #33087



- Manufactured as one of the toughest Brush Cutters available
- Cut grass or brush up to 4"
- Great for cleaning trails or construction sites
- Painted using a 2 part Urethane process for an exceptional finish

SPECIFICATIONS

Blade Carrier	Laser Cut Plate
Blade Rotation	Counter Clockwise
Cutting Capacity	Up to 4"
Drive	Eskridge
Motor	11.9 cu. in.
Hydraulic Couplers	Flat Face 1/2" Body - ISO16028
Hydraulic Hoses	3/4"
Max. PSI	3000 PSI
Wear Bars	3/8" Thick - Welded on
Front Chain Mount	Replaceable 5/16" chain - 5 links long
Rear Chain Mount	Replaceable 5/16" chain - 3 links long

ADDITIONAL SPECIFICATIONS	60" MODEL #33085	66" MODEL #33093	72" MODEL #33086	78" MODEL #33087
Overall Width	64"	70"	76"	85"
Overall Length	74"	82"	90"	96"
Overall Height	24"	24"	24"	24"
Blade, Bolts	Blades: 5/8" x 5" and 2.5" Drop - 19.25" hole to tip Bolts: BB100A	Blades: 5/8" x 5" and 2.5" Drop - 19.25" hole to tip Bolts: BB100A	Blades: 5/8" x 5" and 2.5" Drop - 25.25 hole to tip Bolts: BB100A	Blades: 5/8" x 5" and 2.5" Drop - 25.25 hole to tip Bolts: BB100A
Blade Carrier	3/4" T1, 27" Diameter	3/4" T1, 35 1/4" Diameter	3/4" T1, 27" Diameter	3/4" T1, 35 1/4" Diameter
Nut	1.25 - 7" Castle Nut	1.25 - 7" Castle Nut	1.25 - 7" Castle Nut	1.25 - 7" Castle Nut
Flow	26 - 40 GPM	26 - 40 GPM	26 - 40 GPM	26 - 40 GPM
Blade Tip Speed	Min @ 26 GPM (7660 FPM) Max @ 40 GPM (11784 FPM)	Min @ 26 GPM (8518 FPM) Max @ 40 GPM (13105 FPM)	Min @ 26 GPM (9245 FPM) Max @ 40GPM (14222 FPM)	Min @ 26 GPM (10301 FPM) Max @ 40 GPM (15848 FPM)
Deck Thickness	1/4"	1/4"	1/4"	1/4"
Weight	975 lbs	1125 lbs	1230 lbs	1595 lbs

BRUSH CUTTERS

OPEN FRONT ROTARY BRUSH CUTTER DIRECT STD FLOW

60" Model #33253 • 66" Model #33254

72" Model #33252 • 78" Model #33255



- Manufactured as one of the toughest Brush Cutters available
- Cut grass or brush up to 3 1/2"
- Great for cleaning trails or construction sites
- Painted using a 2 part Urethane process for an exceptional finish

SPECIFICATIONS

Blade Carrier	Laser Cut Plate
Blade Rotation	Counter Clockwise
Cutting Capacity	Up to 3.5"
Drive	Eskridge
Motor	6.1 cu. in.
Hydraulic Couplers	Flat Face 1/2" Body - ISO16028
Hydraulic Hoses	3/4"
Max. PSI	3000 PSI
Wear Bars	3/8" Thick - Welded on

ADDITIONAL SPECIFICATIONS	60" MODEL #33253	66" MODEL #33254	72" MODEL #33252	78" MODEL #33255
Overall Width	64"	70"	75.5"	85"
Overall Length	74"	82"	88"	96"
Overall Height	26"	26"	26"	26"
Blade, Bolts	Blades: 5/8" x 5" and 2.5" Drop - 19.25" hole to tip / Bolts: BB100A	Blades: 5/8" x 5" and 2.5" Drop - 19.25" hole to tip Bolts: BB100A	Blades: 5/8" x 5" and 2.5" Drop - 25.25 hole to tip Bolts: BB100A	Blades: 5/8" x 5" and 2.5" Drop - 25.25 hole to tip Bolts: BB100A
Blade Carrier	3/4" T1, 27" Diameter	3/4" T1, 32" Diameter	3/4" T1, 27" Diameter	3/4" T1, 35 1/4" Diameter
Nut	1.25 - 7" Castle Nut	1.25 - 7" Castle Nut	1.25 - 7" Castle Nut	1.25 - 7" Castle Nut
Flow	15 - 25 GPM	15 - 25 GPM	15 - 25 GPM	15 - 25 GPM
Blade Tip Speed	Min @ 15 GPM (8547 FPM) Max @ 25 GPM (14244 FPM)	Min @ 15 GPM (9587 FPM) Max @ 25 GPM (15978 FPM)	Min @ 15 GPM (8482 FPM) Max @ 25 GPM (14136 FPM)	Min @ 15 GPM (11594 FPM) Max @ 25 GPM (19323 FPM)
Deck Thickness	1/4"	1/4"	1/4"	1/4"
Weight	950 lbs	1120 lbs	1220 lbs	1585 lbs

OPEN FRONT ROTARY BRUSH CUTTER GEAR BOX STD FLOW

60" Model #33257 • 66" Model #33258

72" Model #33256 • 78" Model #33259



- Manufactured as one of the toughest Brush Cutters available
- Cut grass or brush up to 3"
- Great for cleaning trails or construction sites
- Painted using a 2 part Urethane process for an exceptional finish

SPECIFICATIONS

Blade Carrier	Laser Cut Plate
Blade Rotation	Counter Clockwise
Cutting Capacity	Up to 3"
Drive	Omni Gear Box
Motor	8.6 cu. in.
Hydraulic Couplers	Flat Face 1/2" Body - ISO16028
Hydraulic Hoses	3/4"
Max. PSI	3000 PSI
Wear Bars	3/8" Thick - Welded on

ADDITIONAL SPECIFICATIONS	60" MODEL #33257	66" MODEL #33258	72" MODEL #33256	78" MODEL #33259
Overall Width	64"	70"	75.5"	85"
Overall Length	74"	82"	88"	96"
Overall Height	26"	26"	26"	26"
Blade, Bolts	Blades: 1/2" x 4" and 2.5" Drop - 19.75" hole to tip / Bolts: BB10	Blades: 5/8" x 5" and 2.5" Drop - 22.25" hole to tip Bolts: BB10	Blades: 5/8" x 5" and 2.5" Drop - 25.25 hole to tip Bolts: BB10	Blades: 5/8" x 5" and 2.5" Drop - 28.25 hole to tip Bolts: BB10
Blade Carrier	3/4" T1 Plate	3/4" T1 Plate	3/4" T1 Plate	3/4" T1 Plate
Nut	1.125 Fine Thread Top Lock	1.125 Fine Thread Top Lock	1.125 Fine Thread Top Lock	1.125 Fine Thread Top Lock
Flow	15-25 GPM	15-25 GPM	15-25 GPM	15-25 GPM
Blade Tip Speed	Min @ 15 GPM (8928 FPM) Max @ 25 GPM (14879 FPM)	Min @ 15 GPM (9928 FPM) Max @ 25 GPM (16549 FPM)	Min @ 15 GPM (10775 FPM) Max @ 25 GPM (17958 FPM)	Min @ 15 GPM (12006 FPM) Max @ 25 GPM (20010 FPM)
Deck Thickness	1/4"	1/4"	1/4"	1/4"
Weight	965 lbs	1135 lbs	1235 lbs	1600 lbs

BRUSH CUTTERS

OPEN FRONT ROTARY BRUSH CUTTER HIGH FLOW

60" Model #33261 • 66" Model #33262

72" Model #33260 • 78" Model #33263



- Manufactured as one of the toughest Brush Cutters available
- Cut grass or brush up to 5"
- Great for cleaning trails or construction sites
- Painted using a 2 part Urethane process for an exceptional finish

SPECIFICATIONS

Blade Carrier	Laser Cut Plate
Blade Rotation	Counter Clockwise
Cutting Capacity	Up to 5"
Drive	Eskridge
Motor	11.9 cu. in.
Hydraulic Couplers	Flat Face 1/2" Body - ISO16028
Hydraulic Hoses	3/4"
Max. PSI	3000 PSI
Wear Bars	3/8" Thick - Welded on

ADDITIONAL SPECIFICATIONS	60" MODEL #33261	66" MODEL #33262	72" MODEL #33260	78" MODEL #33263
Overall Width	64"	70"	75.5"	85"
Overall Length	74"	82"	88"	96"
Overall Height	26"	26"	26"	26"
Blade, Bolts	Blades: 5/8" x 5" and 2.5" Drop - 19.25" hole to tip / Bolts: BB100A	Blades: 5/8" x 5" and 2.5" Drop - 19.25" hole to tip Bolts: BB100A	Blades: 5/8" x 5" and 2.5" Drop - 25.25 hole to tip Bolts: BB100A	Blades: 5/8" x 5" and 2.5" Drop - 25.25 hole to tip Bolts: BB100A
Blade Carrier	3/4" T1 Plate	3/4" T1 Plate	3/4" T1 Plate	3/4" T1 Plate
Nut	1.25 - 7" Castle Nut	1.25 - 7" Castle Nut	1.25 - 7" Castle Nut	1.25 - 7" Castle Nut
Flow	26-40 GPM	26-40 GPM	26-40 GPM	26-40 GPM
Blade Tip Speed	Min @ 26 GPM (7660 FPM) Max @ 40 GPM (11784 FPM)	Min @ 26 GPM (8518 FPM) Max @ 40 GPM (13105 FPM)	Min @ 26 GPM (9245 FPM) Max @ 40GPM (14222 FPM)	Min @ 26 GPM (10301 FPM) Max @ 40 GPM (15848 FPM)
Deck Thickness	1/4"	1/4"	1/4"	1/4"
Weight	1000 lbs	1150 lbs	1255 lbs	1620 lbs

UTILITY ROCK BUCKET/SKELETON

72" with 3/8" Tines Model #23000

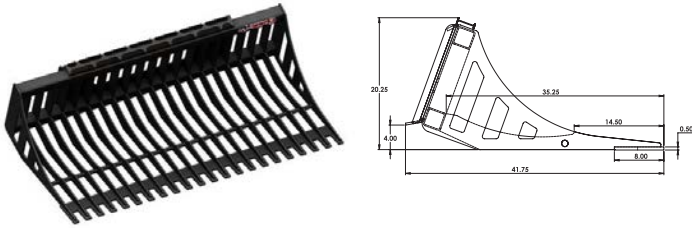

- Engineered for loading rock, sifting debris from dirt or sand, general debris removal and more. Dig, grab, pull, clear and sift with one attachment.
- Works great for back dragging and leveling.
- Heavy duty skeleton frame of the bucket provides the durability to meet the most demanding jobs and toughest conditions. Unique tooth design to hold materials in the bucket.

SPECIFICATIONS

Overall Width	72"
Overall Height	20.25"
Overall Depth	41.75"
Inside Depth of Bucket	35.25"
Cutting Edge	1/2" x 8" - Grade 50
Top Tube	3" x 3" x 3/16"
Bottom Tube	3" x 3" x 3/16"
Weight	550 lbs

**Recommended for loaders up to
2250 lb total lift capacity**

STANDARD ROCK BUCKET/SKELETON

72" Model #33047 • 79" Model #33062 • 82" Model #33056



- A little more robust than the standard duty edition. Features one piece tines and a heavier angle iron cross bar.
- Engineered for loading rock, sifting debris from dirt or sand, general debris removal and more. Dig, grab, pull, clear and sift with one attachment.
- Heavy duty skeleton frame of the bucket provides the durability to meet the most demanding jobs and toughest conditions. Unique tooth design to hold materials in the bucket.

SPECIFICATIONS

Overall Width	72", 79", 82"
Overall Height	21"
Overall Depth	40.5"
Inside Depth of Bucket	33"
Tines	3/8" - Grade 50
Spacing Between Tines	3"
Cutting Edge	1/2" x 8" - Grade 50
Top Tube	3" x 4" x 1/4"
Bottom Tube	2" x 4" x 1/4"
Weight	72" = 600 lbs, 79" = 687 lbs 82" = 715 lbs

BUCKETS

HEAVY DUTY ROCK BUCKET/SKELETON

72" Model #33001 • 79" Model #33154 • 82" Model 33172

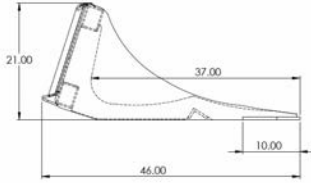

- Perfect tool for digging material from demolition jobs
- Unique tooth design to hold material in bucket
- Clears roots and rocks while leaving the dirt behind

SPECIFICATIONS

Overall Width	72", 79", 82"
Overall Height	21"
Overall Depth	46"
Inside Depth of Bucket	37"
Tines	3/8" - Grade 50
Width Between Tines	3"
Cutting Edge	1/2" x 10" - Grade 50
Top Tube	3" x 4" x 1/4"
Bottom Tube	3" x 4" x 1/4"
Weight	72" = 700 lbs, 79" = 768 lbs 82" = 803 lbs

HEAVY DUTY ROCK BUCKET 5" SPACING

72" Model #33165 • 79" Model #33158 • 82" Model #33166

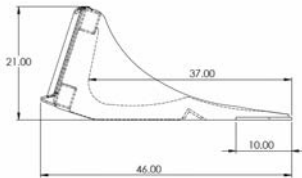

- Heavy duty digging and lifting
- Good for large rocks

SPECIFICATIONS

Overall Width	72", 79", 82"
Overall Height	21"
Overall Depth	46"
Inside Depth of Bucket	37"
Tines	3/8" - Grade 50
Width Between Tines	5"
Cutting Edge	1/2" x 10" - Grade 50
Top Tube	3" x 4" x 1/4"
Bottom Tube	3" x 4" x 1/4"
Weight	72" = 550 lbs, 79" = 598 lbs 82" = 612 lbs

HEAVY DUTY LOW PROFILE BUCKET

60" Model #33037 • 68" Model #33053
 72" Model #33013 • 78" Model #33042
 80" Model #33023 • 84" Model #33024

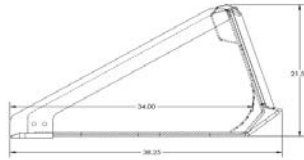

- Low profile for better visibility of the cutting edge
- Reinforced bucket liner for longer life and less buckling
- Holes in cutting edge for optional 5/8" x 8 bolt on cutting edge (6" bolt spacing)

TOOTH BUCKET

60" Model #33037T • 68" Model #33053T
 72" Model #33013T • 78" Model #33042T
 80" Model #33023T • 84" Model #33024T

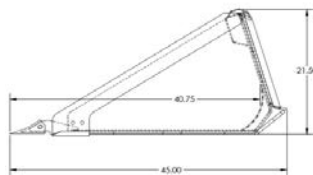

- Excellent cutting edge visibility
- Loosen hard pack dirt
- High break out force
- Versatile bucket for tough digging and material handling

SPECIFICATIONS

Overall Width	60", 68", 72", 78", 80" & 84"
Overall Height	21.5"
Overall Depth	38.25"
Bucket Thickness	3/16"
Side Plates	3/16"
Step Bent Insert	3/16"
Side Cutting Edge	3/8" - Grade 50
Wear Bars	3/8" - Grade 50
Mounting Plate	5/16" - HR Steel
Cutting Edge	3/4" x 6"
Step	Extruded Grips
Struck Capacity cu. ft.	60" = 13.2, 68" = 15, 72" = 15.9 78" = 17.5, 80" = 17.75, 84" = 18.5
Heaped Capacity cu. ft.	60" = 15.8, 68" = 18, 72" = 19 78" = 20.5, 80" = 20.12, 84" = 22.25
Weight	60" = 485 lbs, 68" = 525 lbs 72" = 530 lbs, 78" = 575 lbs 80" = 610 lbs, 84" = 630 lbs

SPECIFICATIONS

Overall Width	60", 68", 72", 78", 80" & 84"
Overall Height	21.5"
Overall Depth	45"
Bucket Thickness	3/16"
Side Plates	3/16"
Step Bent Insert	3/16"
Side Cutting Edge	3/8" - Grade 50
Wear Bars	3/8" - Grade 50
Mounting Plate	5/16" - HR Steel
Cutting Edge	3/4" x 6"
Step	Extruded Grips
Struck Capacity cu. ft.	60" = 13.2, 68" = 15, 72" = 15.9 78" = 17.5, 80" = 17.75, 84" = 18.5
Heaped Capacity cu. ft.	60" = 15.8, 68" = 18, 72" = 19 78" = 20.5, 80" = 20.12, 84" = 22.25
Weight	60" = 565 lbs, 68" = 605 lbs, 72" = 620 lbs, 78" = 665 lbs 80" = 705 lbs, 84" = 730 lbs

BUCKETS

UTILITY BUCKET

66" Model #33012 • 72" Model #33184 • 84" Model #33185

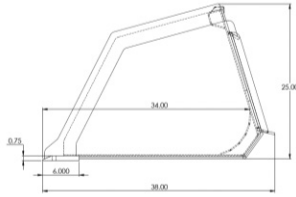

- Inside of bucket is fully welded for added strength
- Excellent for general purpose use
- Option to add bolt-on cutting edge

SPECIFICATIONS

Overall Width	66", 72", 84"
Overall Height	25"
Overall Depth	38.5"
Bucket Thickness	3/16"
Side Plates	3/16"
Step Bent Insert	3/16"
Side Cutting Edge	3/8" - Grade 50
Wear Bars	3/8" - Grade 50
Mounting Plate	5/16" - HR Steel
Cutting Edge	3/4" x 6"
Step	Extruded Grips
Struck Capacity cu. ft.	66" = 20.5, 72" = 21.9, 84" = 25
Heaped Capacity cu. ft.	66" = 24.6, 72" = 26.2, 84" = 30
Weight	66" = 576 lbs, 72" = 630 lbs 84" = 735 lbs

STUMP BUCKET

Model #33040

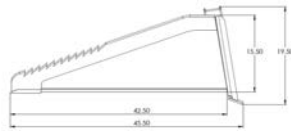

- Excellent for digging up stumps, removing rocks & digging trenches
- Takes the work out of digging
- Painted using a 2 part Urethane process for an exceptional finish

SPECIFICATIONS

Overall Width	45"
Overall Height	18"
Overall Depth	44"
Bucket Thickness	5/16" - Grade 50
Side Cutting Edge	1/2" - Grade 50
Wear Bars	1/2" - Grade 50
Cutting Edge	3/4" x 6"
Weight	353 lbs

MANURE BUCKET

54" Model #33316 • 66" Model #33278
72" Model #33247 • 78" Model #33279



- Manure Buckets are great for picking up manure and other materials while leaving soil and debris behind
- Excellent for general purpose use
- Also works great for picking up loose hay
- Inside of bucket is fully welded for added strength
- Heavy duty design
- 3 Sizes available for multiple applications
- 1144 Stress Relieved Tines - bolt in style means that the tines are easily replaceable should one get damaged

SPECIFICATIONS

Overall Width	54", 66", 72", 78"
Overall Height	25"
Overall Depth	38.5"
Depth of Bucket	35"
Tines	54" = 9, 66" = 11, 72" = 11, 78" = 12
Bucket Thickness	1/4"
Tine Spacing	54" = 9 tines, 5" space, 66" = 9 tines, 6.75" space, 72" = 11 tines, 6.75" space, 78" = 12 tines, 6.6" space
Weight	54" = 498 lbs, 66" = 522 lbs 72" = 541 lbs, 78" = 582 lbs

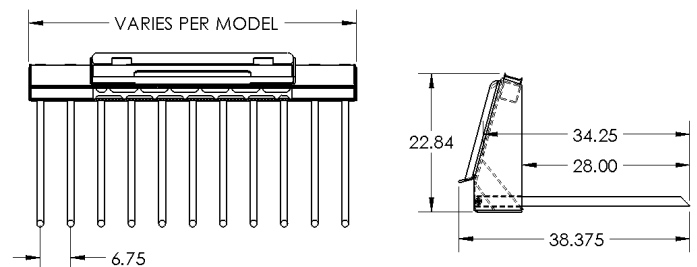

TREE SPADE

Model #33131



- Durable construction for years of use
- Transplant trees
- Remove Small Rocks
- Fully Reinforced

SPECIFICATIONS

Overall Width	47.5"
Overall Height	25"
Overall Depth	51"
Bucket Thickness	3/8" - Grade 50
Top Tube	4" x 4" x 1/4"
Cutting Edge	1/2" x 3"
Back Plate	5/16" - Grade 50
Weight	405 lbs

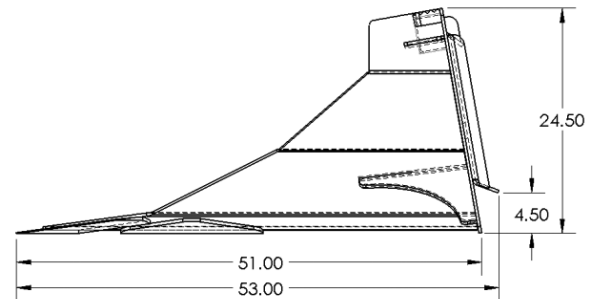

ROCK DIGGER

Model #33041



- 1 inch T-1 Tines
- 7.5" between tines
- Dig out large rocks and stumps with ease

SPECIFICATIONS

Overall Width	41.75"
Overall Height	19.25"
Overall Depth	31.25"
Tines	1" T-1 Steel
Mounting Plate	5/16" - Grade 50
Cutting Edge	3/4" x 6" - 1055 Steel
Tubing	3" x 4" x 1/4"
Weight	334 lbs

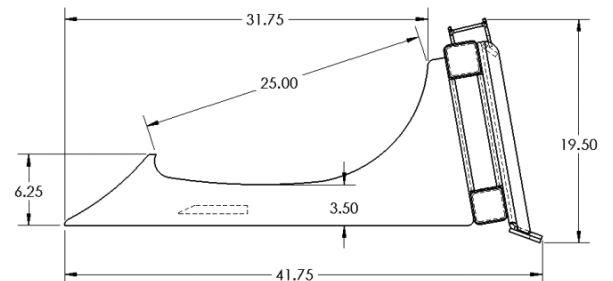

LANDSCAPING

TREE PULLER - LOW PROFILE

Model #33351



- Designed for removal of small trees and brush - making land clearing easier and faster.
- Heavy wall tube and heavy reinforcement plates make these the strongest in the market in their class.
- Serrated grip teeth hold tight onto the material.

SPECIFICATIONS

Overall Width	46"
Overall Height	28"
Overall Depth	28.4"
Grapple Opening	10" / 12.75"
Grapple Teeth	5/8" - Grade 50
Flat Face Couplers	Included
Hydraulic Hoses	3/8"
Cylinder	2" x 8" Tie Rod
Main Pin	1 1/2" Greasable
Weight	366 lbs

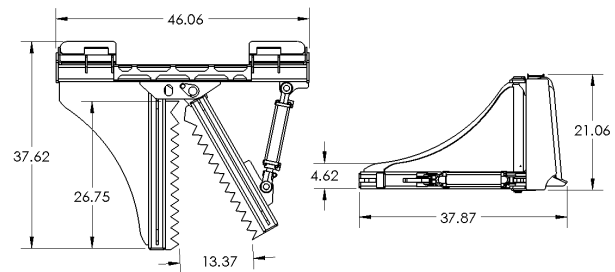

TREE PULLER - HD

Model #33350



- Designed for removal of small trees and brush - making land clearing easier and faster.
- Heavy wall tube and heavy reinforcement plates make these the strongest in the market in their class.
- Serrated grip teeth hold tight onto the material.
- Repositionable clamping arm for grabbing small saplings up thru 12" diameter.
- Works in both Horizontal and Vertical positions due to its multiple rows of clamping teeth.

SPECIFICATIONS

Overall Width	46"
Overall Height	21.6"
Overall Depth	37.9"
Grapple Opening	12.5"
Grapple Teeth	5/8" - Grade 50
Flat Face Couplers	Included
Hydraulic Hoses	3/8"
Cylinder	2" x 8" Welded
Main Pin	1 1/2" Greasable
Weight	346 lbs

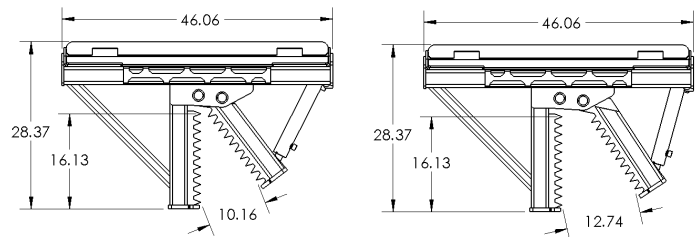

LOG FORK

Model #33217



The Log fork is a unique design that is perfect for grabbing logs from a stack or stacking logs. This attachment is also great for handling rocks, brush and stumps.



SPECIFICATIONS

Overall Width	45.5"
Overall Height - Closed	28"
Overall Height - Open	33.5"
Overall Depth	41"
Grapple Opening	30"
Depth of Bucket	30"
Side Plates	3/4" - Grade 50
Tubing	3" x 3" x 3/16"
Grapple Arms	1/2" Grade 50 - Laser Cut
Cylinder	2" x 8" - Welded Cross Tube
Main Pin	1.50" Diameter - Greasable
Hydraulic Couplers	Factory Installed, Flat face
Hydraulic Hoses	3/8"
Max. PSI	3000 PSI
Weight	460 lbs

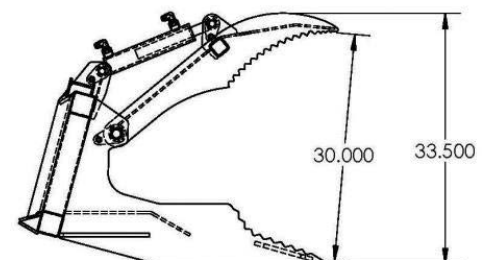
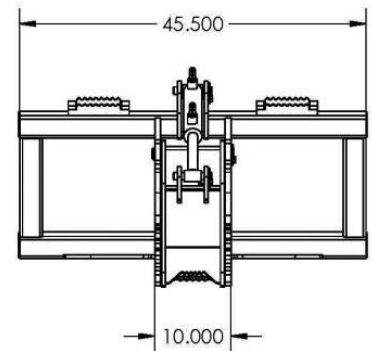
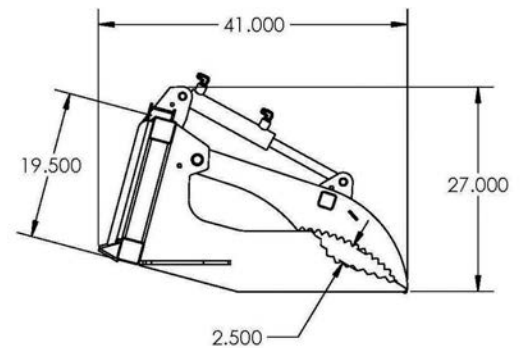

LANDSCAPING

TREE SHEAR

Model #33300

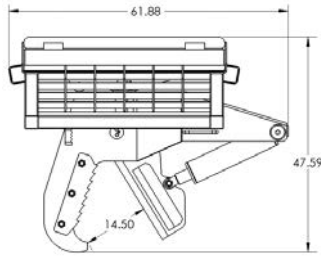

The Legend Tree Shears are designed to shear trees up to 14" in diameter* and will couple with your equipment with a standard skid loader mounting plate. The serrated teeth-edge design gives the Legend Tree Shears a strong, grapple-like feature to pick up and remove debris. These teeth also hold the tree securely during the cutting cycle allowing all of the machine's hydraulic power to focus on cutting the tree. A single shearing blade made from 1" T1 provides low cost maintenance for many years of hard use.

The shear is designed with the shear being flush to the ground. Major pivot points are machined and greasable for long life and being made from high tensile steel ensures longevity. Single blade shearing promotes the tree to fall in the direction of the blades travel. The heavy duty fence provides pushing power and protection for the operator.

SPECIFICATIONS

Overall Width	62"
Overall Height	49"
Overall Depth	48"
Shear Jaw Thickness	1" - Grade 50
Grip Teeth Thickness	3/4" - Grade 50
Cylinder	5" Bore, 2" Rod
Cutting Edge	1" - T-1 Steel
Weight	934 lbs

LAND PLANE

79" Model #33022 • 101" Model #33311



- Bi-Directional to speed up site preparation
- Heavy Duty cutting edges
- Level and grade landscape jobs
- Prepares lawns for seeding or turf placement

SPECIFICATIONS

Overall Width	79", 101"
Overall Height	19.5" Adjustable
Overall Depth	50"
Frame Work	3/8" - Grade 50
Cutting Edge	1/2" x 6" - Front & Back
Mounting Plate	Adjustable
Expanded Metal	5/16" Grade 50 - Laser Cut
Front Bucket Hooks	Standard
Weight	79" = 550 lbs, 101" = 667 lbs

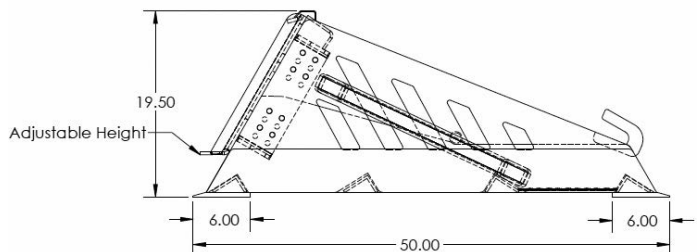

LOG SPLITTER

36" Model #33187



SPECIFICATIONS

Overall Width	45.375"
Overall Height	22.25"
Overall Length	107"
Cylinder	4" Bore
Cutting Edge	1" - T1 Steel
Force	20 Ton
Weight	36" = 680 lbs

The Legend Log Splitter is designed to split trees with up to 20 tons force* and will couple with your equipment with a standard skid loader mounting plate. A single shearing blade made from 1" T1 provides low cost maintenance, splitting the hardest woods is not a challenge.

Optional 4 way wedge (shown) can be provided to speed the process of splitting. Easily installed / removed with a couple bolts.

Grip and split design lets the operator stay in the cab and maneuver around to the logs, grabbing them, lifting them, and splitting them over the pile.

* Pressure may vary depending on skid loaders pump output.

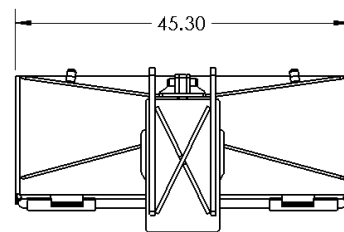
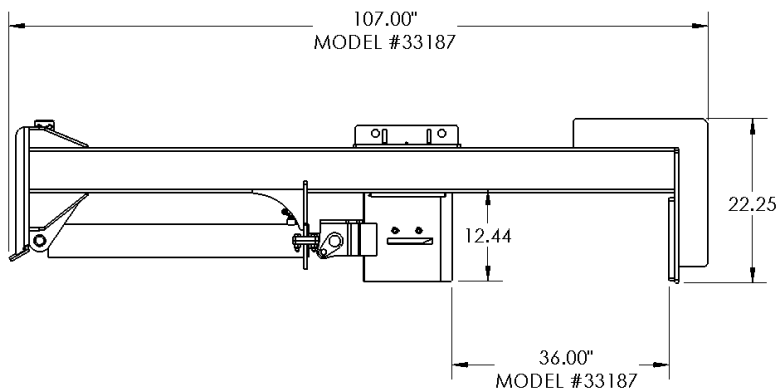

STANDARD DUTY PALLET FORKS

Model #90001W



- Brick Guard allows for clear vision of load while providing protection to the operator.
- Brick guard is removable.
- Ideal for moving materials around the job site.
- Designed for moving palletized, equal loaded and strapped materials only.
- Adjustable forks allow you to make adjustments from 8" to 47" wide. Rail lockdown for improved safety. Forks are fixed at the top and heel to prevent bouncing while carrying loads.
- Capacity is based on no more than 1/2 load per fork and load no more than 1/2 way out on each fork.
- Built to perform and outlast the competitions light duty pallet forks
- Comes with Standard 48" Forks

SPECIFICATIONS

Overall Width	45"
Overall Height	42"
Depth	9.5"
Top and Bottom Rails	3/8" - Grade 50
Fork Length	48"
Fork Width	4"
Fork Thickness	1 3/8"
Tines	Class II Part #80489
Tine Load Capacity at 24" Load Center (per pair)	4400 lbs
Weight	345 lbs

DISCLAIMER:

These are light duty pallet forks, designed for palletized material using light duty machinery. We suggest that the machine does not exceed 1450 lbs. lift capacity. Tine ratings are higher than the frame limit. User must understand the capabilities of their equipment and attachments prior to use. Misuse of the Light Duty Pallet Forks will void manufacturer's warranty. Load must be lifted evenly to keep frame from bending.

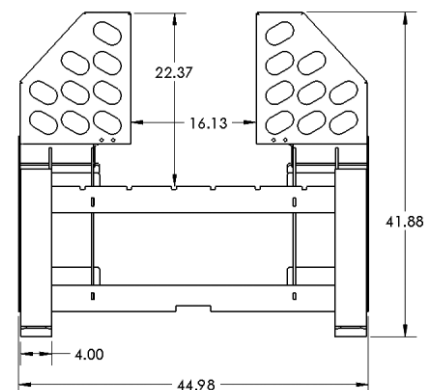
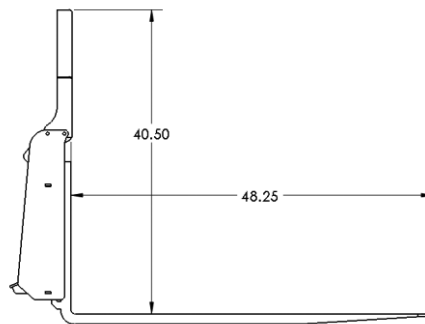

PALLET FORKS

HEAVY DUTY PALLET FORKS

Model #33019-48



HEAVY DUTY WALK-THRU PALLET FORKS

Model #33019-48W



- Heavy Duty Full Brick Guard allows for clear vision of load while providing the best and strongest protection to the operator.
- Ideal for moving materials around the job site. Designed for moving palletized and strapped materials only.
- Adjustable forks allow you to make adjustments from 8" to 47" wide. Rail lockdown for improved safety. Forks are fixed at the top and heel to prevent bouncing while carrying loads.
- Built to perform and outlast the competition
- Comes with Standard 48" - 4400# Forks
- Optional 48" - 5500# Forks available.
- Optional 60" - 5500# Forks available

SPECIFICATIONS

Overall Width	46"
Overall Height	40"
Depth	9.5"
Top and Bottom Rails	1/2" - Grade 50
Fork Length	48"
Fork Width	4"
Fork Thickness	1 3/8"
Tines	Class II Part #80489
Est. Load Capacity at 24" Load Center (per pair)	4400 lbs
Weight	525 lbs

Designed for use with palletized material only. Lift limit is determined by fork capacity or loader capacity, whichever is less. Capacity is based on no more than 1/2 load per fork and load no more than 1/2 way out on each fork.

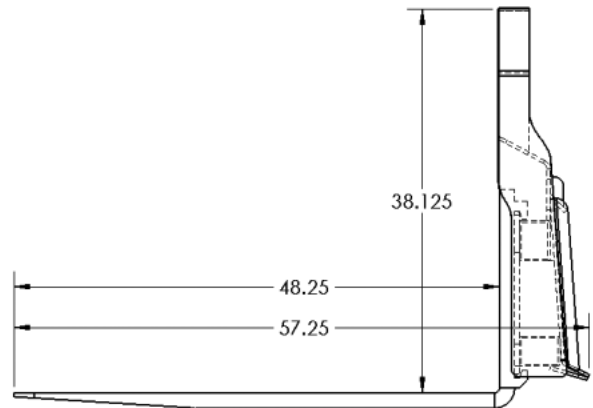
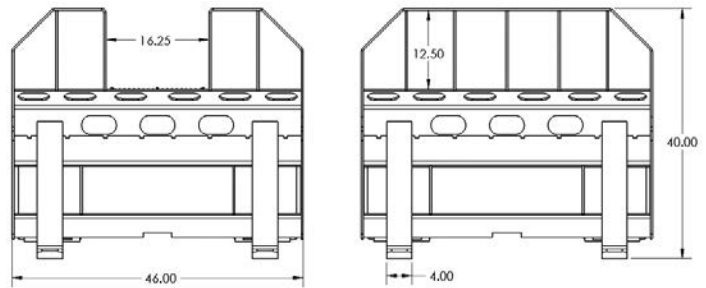

HEAVY DUTY 6' WIDE PALLET FORKS

Model #33106-48W



**Optional 3rd Fork Shown

- Heavy Duty Full Brick Guard allows for clear vision of load while providing the best and strongest protection to the operator.
- Ideal for moving wide materials around the job site. Designed for moving palletized and strapped materials only.
- Adjustable forks allow you to make adjustments from 8" to 69" wide. Rail lockdown for improved safety. Forks are fixed at the top and heel to prevent bouncing while carrying loads.
- Built to perform and outlast the competition.
- Comes with (2) Standard 48" - 4400# Forks
- Optional 48" - 4400# 3rd Fork available**
- Optional 48" - 5500# Forks available.
- Optional 60" - 5500# Forks available

SPECIFICATIONS

Overall Width	70"
Overall Height	40"
Depth	9.5"
Top and Bottom Rails	1/2" - Grade 50
Fork Length	48"
Fork Width	4"
Fork Thickness	1 3/8"
Tines	Class II Part #80489
Tine Load Capacity at 24" Load Center (per pair)	4400 lbs
Weight	564 lbs

Designed for use with palletized material only. Lift limit is determined by fork capacity or loader capacity, whichever is less. Capacity is based on no more than 1/2 load per fork and load no more than 1/2 way out on each fork.

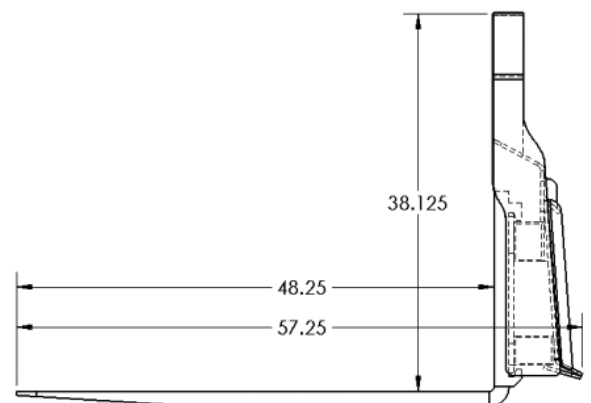
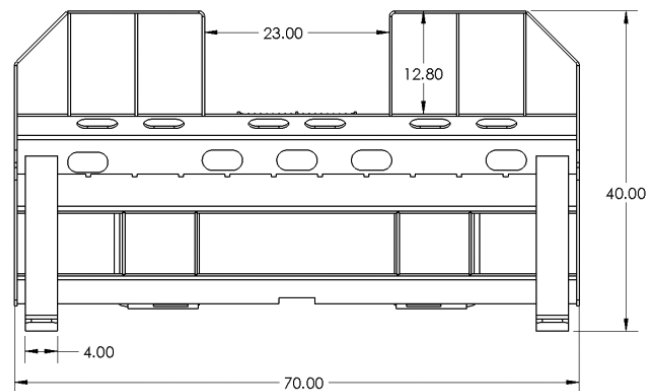

PALLET FORKS

CLAMP-ON PALLET FORKS

Model #33179

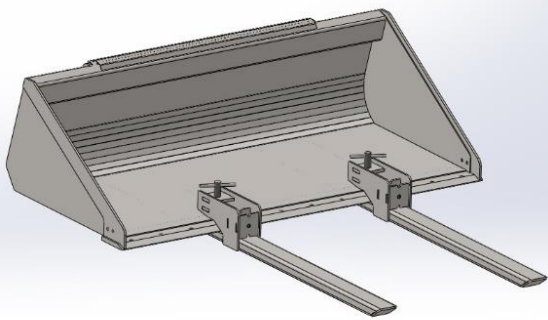

Bucket Not Included

- Durable construction for years of use
- Easy on/off design for added convenience
- Mounts to most loader buckets without tools
- Built-in stake pocket for a 2 x 4 to be installed as an upright backstop
- Easy adjustment to any pallet width
- Built-in stake pocket for a 2 x 4 to be installed as an upright backstop

SPECIFICATIONS

Lift Capacity (per Set of 2 Pallet Forks)	2000 lbs
Overall Tine Length	41.25"
Tine Width	4"
Tine Height	2"
Threaded Clamp Rod	1-6 Acme
Throat Opening	1 3/8"
Throat Depth	8"
Weight (each)	61 lbs

Designed for use with palletized material only. Lift limit is determined by fork capacity or loader capacity, whichever is less. Capacity is based on no more than 1/2 load per fork and load no more than 1/2 way out on each fork.



PALLET FORK CLAMP ON TRAILER MOVER

Model #33287

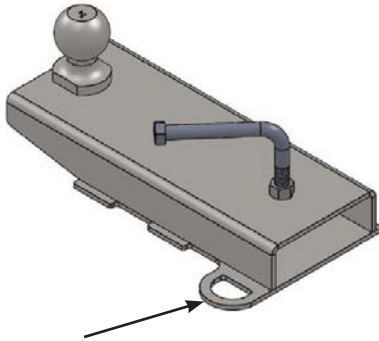

Attach strap or small chain from pallet fork brick guard to this loop for added safety

- Durable construction for years of use
- Easy on/off design for added convenience
- Mounts to most Fork Tines without tools
- Comes Standard with 2" Ball Installed

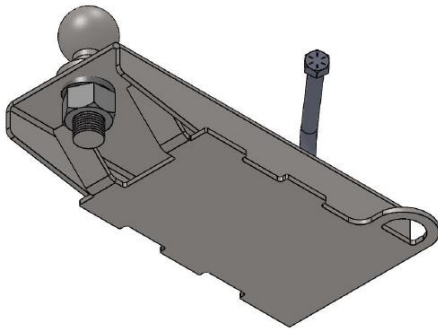

SPECIFICATIONS

Overall Length	12.75"
Overall Width	7.25"
Overall Height	5"
Threaded Clamp Bolt	1/2" - 13
Opening Width for Fork Tine	4 5/8"
Opening Height for Fork Tine	1 9/16"
Weight	11 lbs

Designed for Light Duty Trailer Moving

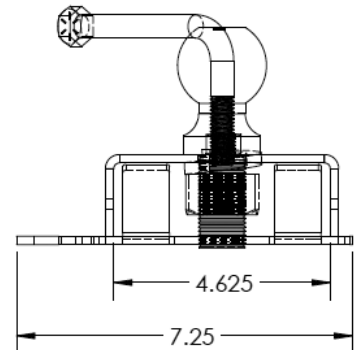
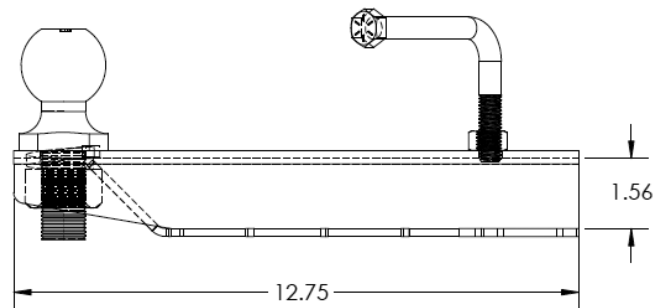

SNOW BUCKET

84" Model #33014 • 96" Model #33020

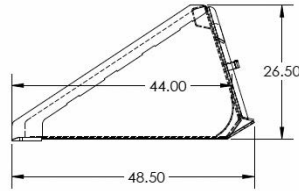

- Low profile with large capacity
- Bolt on cutting edge available
- For snow or lighter materials
- Designed so you can see the cutting edge

SPECIFICATIONS

Overall Width	84", 96"
Overall Height	26.5"
Overall Depth	48.5"
Bucket Thickness	3/16"
Side Plates	3/16"
Step Bent Insert	3/16"
Side Cutting Edge	3/8" - Grade 50
Wear Bars	3/8" - Grade 50
Mounting Plate	5/16" - A-36 Steel, Extra Tall
Cutting Edge	3/4" x 6"
Step	Laser & Formed, Welded on Back
Struck Capacity cu. ft.	84" = 27.3, 96" = 31.2
Heaped Capacity cu. ft.	84" = 32.7, 96" = 37.4
Weight	84" = 700 lbs, 96" = 800 lbs

SCREEN SNOW BUCKET

84" Model #33163 • 96" Model #33162
102" Model #33196 • 108" Model #33197

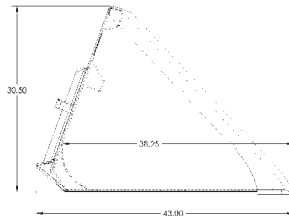

Engineered Snow Buckets are designed for snow or light debris. They offer a weld-on cutting edge backed up by wear-bars that strengthen the bucket bottom for added durability and keep the bucket skin from wearing from the bottom.

The back is screened to allow the operator to visibly see the cutting edge while loading the bucket. The screen portion also stops heaped material from completely flowing over.

Holes in the welded cutting edge allow for bolting on a 5/8 x 8" optional cutting edge (sold separately). 6" bolt spacing standard on all buckets.

SPECIFICATIONS

Overall Width	84", 96", 102", 108"
Overall Height	84" = 30.5", 96" = 30.5" 102" = 30.5", 108" = 30.5"
Overall Depth	84" = 43", 96" = 38.25" 102" = 38.25", 108" = 38.25"
Bucket Thickness	3/16"
Side Plates	3/16"
Step Bent Insert	3/16"
Side Cutting Edge	3/8" - Grade 50
Wear Bars	3/8" - Grade 50
Mounting Plate	5/16"
Cutting Edge	3/4" x 6"
Step	Serrated
Struck Capacity cu. ft.	84" = 30.11, 96" = 34.19 102" = 36.8, 108" = 39.0
Heaped Capacity cu. ft.	84" = 36.13, 96" = 41.02 102" = 44.16, 108" = 46.80
Weight	84" = 742, 96" = 809 102" = 836, 108" = 898

SNOW REMOVAL

SNOW PUSHER

96" Model #33017 • 120" Model #33021 • 144" Model #33207

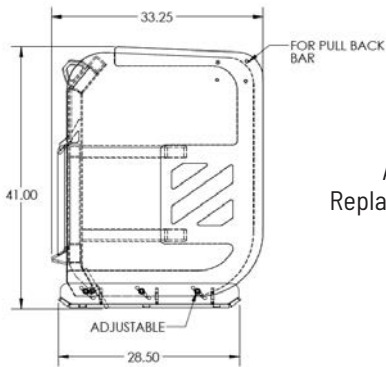

Adjustable & Replaceable Wear Bars

SPECIFICATIONS

Overall Width	96", 120", 144"
Overall Depth	33.25"
Overall Height	41"
Bucket Thickness	3/16"
Side Plates	3/16"
Side Plate Reinforcement	1/4"
Wear Bars	1/2" with 4 Adjustments
Mounting Plate	5/16" - HR Steel
Cutting Edge	1/2" x 7" - Grade 50
Weight	96" = 737 lbs, 120" = 867 lbs, 144" = 1042

SNOW PUSHER ACCESSORIES

96" & 120" Outside
Model #33017C-1

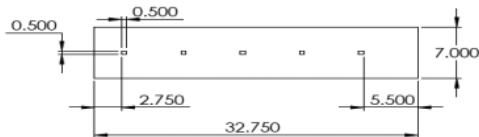

96" Middle
Model #33017C-2

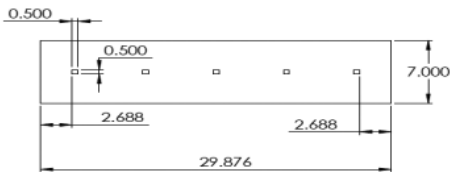

120" Middle
Model #33021C-1

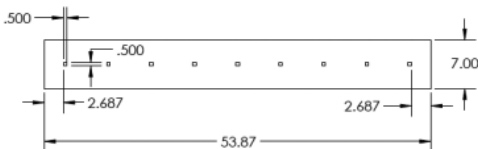

SPECIFICATIONS

MODEL #	DESCRIPTION	WEIGHT
33017-PB	96" Pull Back Bar	182 lbs
33021-PB	120" Pull Back Bar	226 lbs
33017C-1	96" Outside	33 lbs
33017C-1	120" Outside	33 lbs
33017C-2	96" Middle	30 lbs
33021C-1	120" Middle	54 lbs
33017B-LH	Skid Shoe Left	23 lbs
33017B-RH	Skid Shoe Right	23 lbs

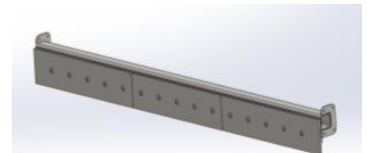
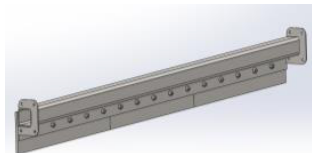

BUCKET MOUNT SNOW PUSHER

144" Model #33249 • 168" Model #33329

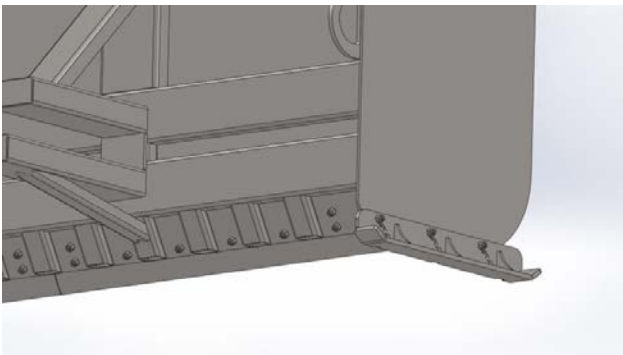
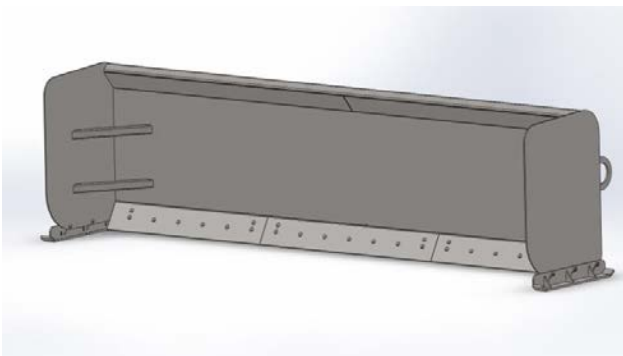
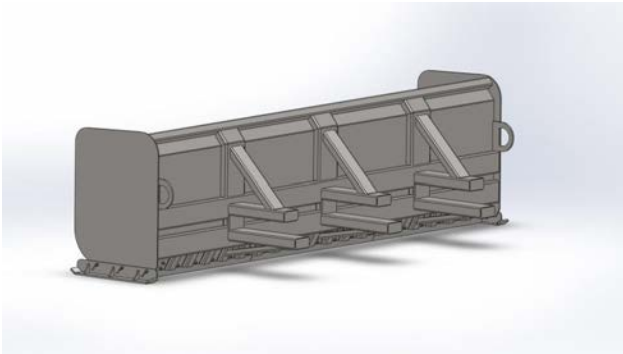

SPECIFICATIONS

Overall Width	144", 168"
Overall Height	41.5"
Overall Depth	54"
Bucket Thickness	3/16"
Side Plates	5/16"
Side Plate Tie Rings	1/2"
Wear Bars	1/2" with 4 Adjustments
Mounting Plate	5/16" - HR Steel
Cutting Edge	1/2" x 7" - Grade 50
Weight	144" = 1300 lbs, 168" = 1516 lbs

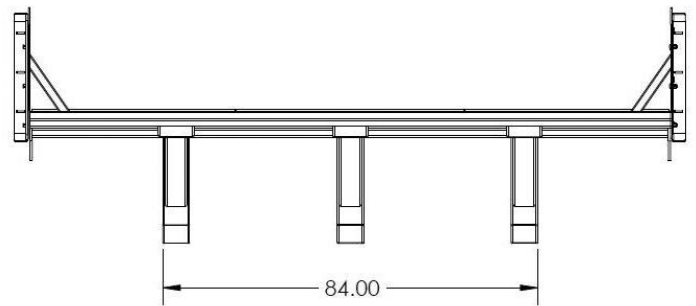

Standard width of bucket mount tubes is 84", if a different size is needed please contact the factory with that information.

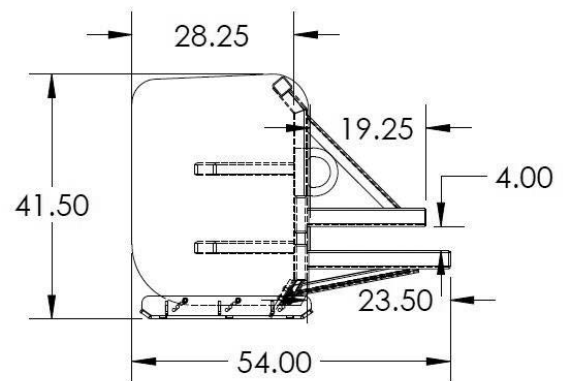

Adjustable & Replaceable Wear Bars

RECEIVER STYLE BALE SPEAR

Model #33016

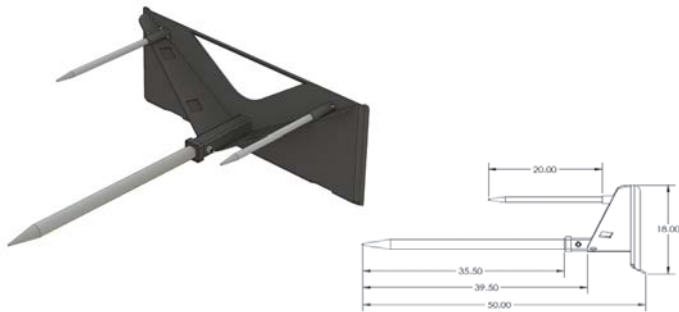

Replaceable Main Spear & Stabilizing Spears

SPECIFICATIONS

Width	46"
Overall Depth	50"
Height	18"
Main Spear	43" Spear - Bolt in Spear 35.5" Usable Length (P#33016-03)
Stabilizer Spear	23" Spear, 20" Usable Length (P#33016-02)
Max Lift	Total Max Load 1500 lbs
Weight	155 lbs

SINGLE BALE SPEAR (ECONO)

Model #33189

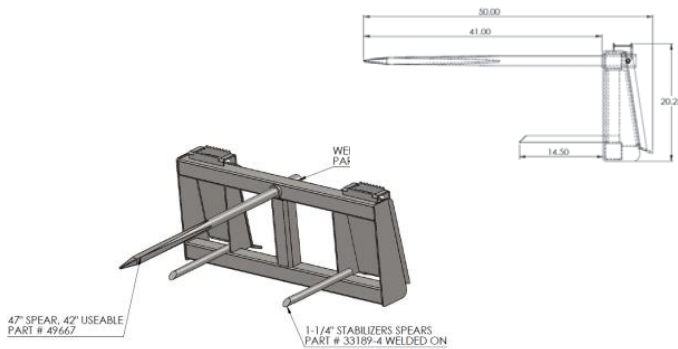

Economical Way to Move a Single Bale

SPECIFICATIONS

Width	46"
Overall Depth	50"
Height	20"
Spear	47" Spear - Bolt in Spear 42" Usable Length (P#49667)
Sleeve	Weld in Sleeve (P#49668)
Max Lift	Total Max Load 3000 lbs
Weight	189 lbs

SINGLE BALE SPEAR

Model #33124

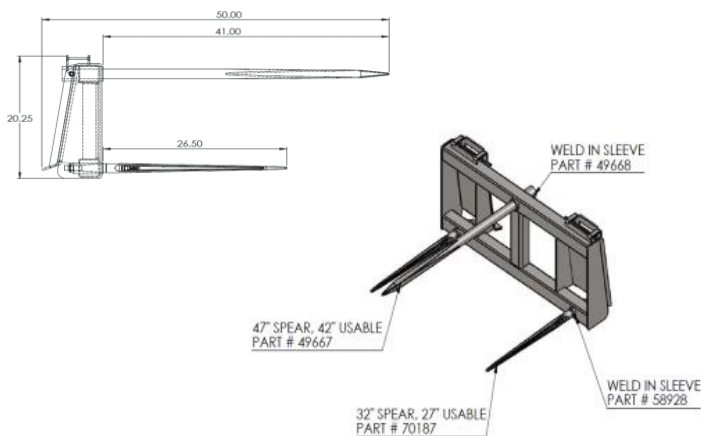

Single Bale Moving • Durable Construction

SPECIFICATIONS

Width	46"
Overall Depth	50"
Height	20"
Main Spear	47" Spear - Bolt in Spear 42" Usable Length (P#49667)
Main Sleeve	Weld in Sleeve (P#49668)
Stabilizer Spear	32" Spear, 27" Usable Length (P#70187)
Stabilizer Sleeve	Weld on Sleeve (P#58928)
Max Lift	Total Max Load 3000 lbs
Weight	189 lbs

HAY HANDLING

DOUBLE BALE SPEAR

Model #33160

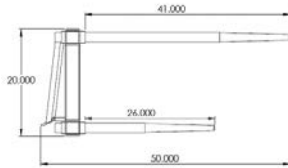

Bottom Lift Ability Allows for Higher Lifting

SPECIFICATIONS

Width	46"
Overall Depth	50"
Height	20"
Width Between Spear	36"
Spear	47" Spear - Bolt in Spear 42" Usable Length (P#49667)
Sleeve	Weld in Sleeve (P#49668)
Stabilizer Spear	1" Cold Roll Round 23" Spear, 18.5" Usable Length (P#33160-7)
Max Lift	Total Max Load 3000 lbs
Weight	190 lbs

TRIPLE BALE SPEAR

Model #33159

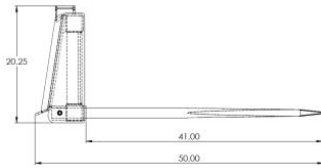
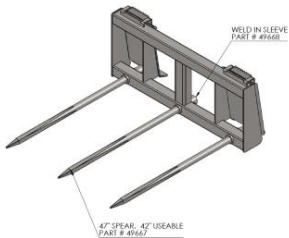

Best Suited for Large Round or Square Bales

SPECIFICATIONS

Width	46"
Overall Depth	50"
Height	20"
Width Between Spears	36"
Spear	47" Spear - Bolt in Spear 42" Usable Length (P#49667)
Sleeve	Weld in Sleeve (P#49668)
Max Lift	Total Max Load 3000 lbs
Weight	224 lbs

DOUBLE ROUND BALE SPEAR

Model #33125

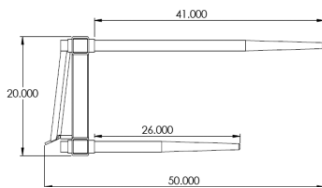

Double Bale Moving Saves Time

SPECIFICATIONS

Width	68"
Overall Depth	50"
Height	20"
Width Between Top Spears	60"
Width Between Bottom Spears	42"
Top Spears	47" Spear - Bolt in Spear 42" Usable Length (P#49667)
Sleeves	Weld in Sleeve (P#49668)
Bottom Spears	32" Spear - Bolt in Spear, 27" Usable Length (P#69122), 3500 lb Max
Max Lift	Total Max Load 3000 lbs
Weight	325 lbs

SQUARE/ROUND BALE SPEAR COMBO

Model #33277

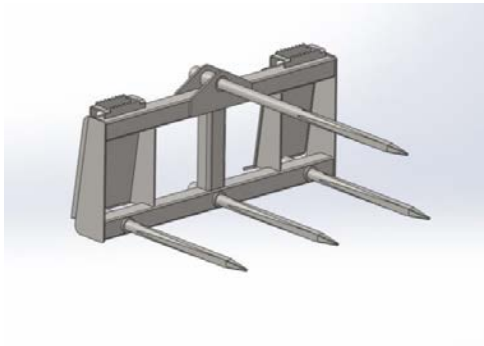

SPECIFICATIONS

Width	46"
Overall Depth	50"
Height	22"
Top Spear	47" Spear - Bolt in Spear 42" Usable Length (P#49667)
Bottom Spears	32" Spear - Bolt in Spear, 27" Usable Length (P#69122)
Sleeves	Weld in Sleeve (P#49668)
Max Lift	Total Max Load 3000 lbs
Weight	220 lbs

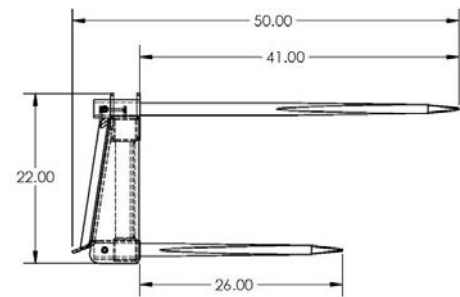

Remove Top Spear When Handling Square Bales
Remove Bottom Center Spear When Handling Round Bales

HAY HANDLING

HEAVY DUTY PALLET FORK/ BALE SPEAR COMBO

Euro Mount Model #33112

Skid Steer Mount Model #33302



Remove the Spears for a Standard Walk-Thru Pallet Fork Attachment.

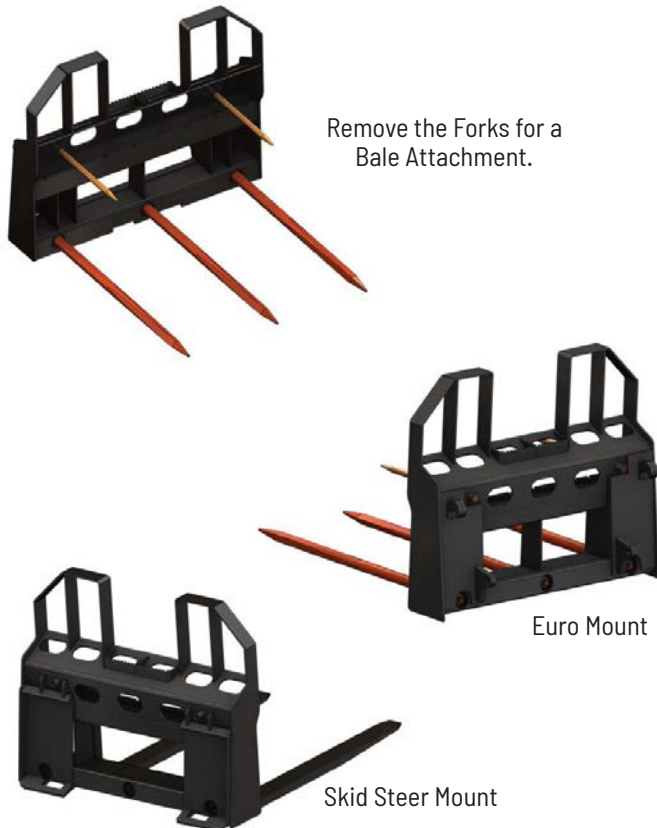

Remove the Forks for a Bale Attachment.

Euro Mount

Skid Steer Mount

SPECIFICATIONS

Overall Width	48.5"
Overall Depth	60"
Overall Height	40.75"
Fork Thickness	1 3/8" Class II
Fork Width	4"
Fork Capacity	4400 lbs
Lifting Spear	2" Diameter Bolt in, 41" Usable
Max Stabilizer Spear	1" Diameter Pin in, 14.75" Usable
Mounting Plate	5/16" - Grade 50
Weight	619 lbs

Designed for use with palletized material only. Lift limit is determined by fork capacity or loader capacity, whichever is less. Capacity is based on no more than 1/2 load per fork and load no more than 1/2 way out on each fork.

PARTS LIST

Skid Steer Mount Frame	33302F
Euro Mount Frame	33112F
1" Stabilizers	33016-02
Pallet Forks	80489
49" Spears	21615181

- The Pallet Fork / Bale Spear Combo is a great combination of 2 products in one.
- Designed for easy conversion from forks to spear. All components are removable for easy customization.
- Walk thru backer give the operator easy access in and out of the machine, while giving you solid ridged protection from bales and palletized items.
- Built to perform and outlast the competition
- Comes with Standard 48" - 4400# Forks
- Optional 48" - 5500# Forks available
- Optional 60" - 5500# Forks available

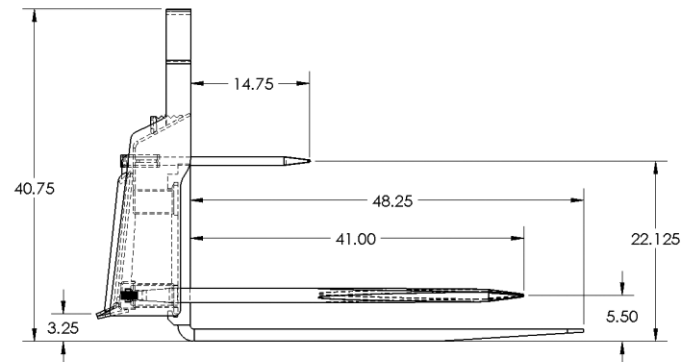

BALE ACCUMULATOR GRAPPLE

Model #55003-S



- Designed as a loader-mounted bale accumulator and grapple fork in one. It lets you gather bales in the field, load them onto a trailer or truck, and unload them using the same piece of equipment. Capable of up to 10 bales at one time.
- Bale accumulator has removable sides for easy grabbing when unloading or pulling bales from a stack.
- Allows for one man operation.
- Quick attach and other mounting styles available for skid loaders and tractor loaders.
- Attachment plate can be moved up or down to suit your needs.



SPECIFICATIONS

Overall Width	84"
Overall Depth	104"
Overall Height	26"
Cylinder	2" x 8" - Welded Cross Tube
Bushings	Machined Wear Resistant Nylon
Hooks	65-45-12 Ductile Iron
Frame	Laser Cut and Formed
Hoses	3/8" - 3000 PSI
Max Lift	10 Bales
Weight	998 lbs

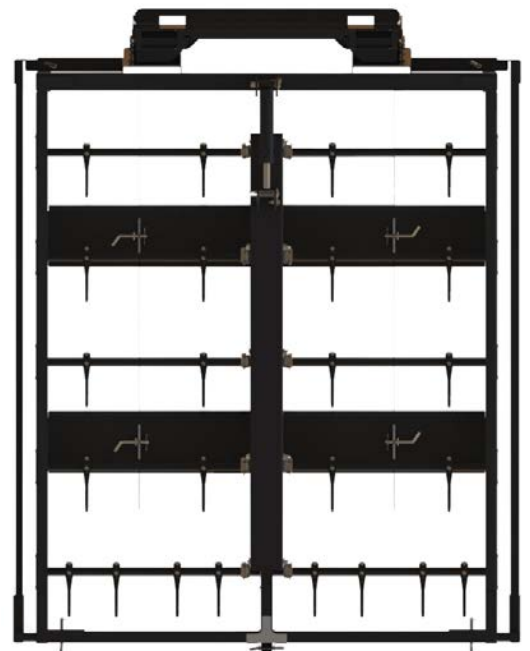

HAY HANDLING

6 PACK BALE ACCUMULATOR GRAPPLE

Model #55004-S



- Hands free haying
- Grabs and lifts 6 square bales at a time
- Removable sides for ease of grabbing when stacked
- Reduces labor - One person can gather, lift load and unload
- Quickly mounts to Skid Steers or Tractors
- Built tough for long lasting use



SPECIFICATIONS

Width	84"
Overall Depth	68"
Height	26"
Cylinder	2" x 8" - Welded Cross Tube, ORB Ports
Bushings	Impact Resistant UHMW
Hooks	65-45-12 Ductile Iron
Frame	Laser Cut and Formed
Hoses	3/8" - 3000 PSI (Hoses Sold Separately)
Max Lift	6 Bales
Weight	600 lbs

3 POINT TRAILER HITCH

Model #44001



- Provides the ability to move trailers without getting off of the tractor
- Built using laser cut parts
- Includes (1) 2" ball, (1) 1 7/8" ball, (2) Cat I lift pins and (1) 3/4" pin
- Heavy duty side lift pins
- Fits Cat I Hitches

SPECIFICATIONS

Overall Width	31"
Overall Depth	2.5"
Overall Height	21"
Material	Grade 50 Steel
Towing Capacity	8000 lbs
Weight	34 lbs

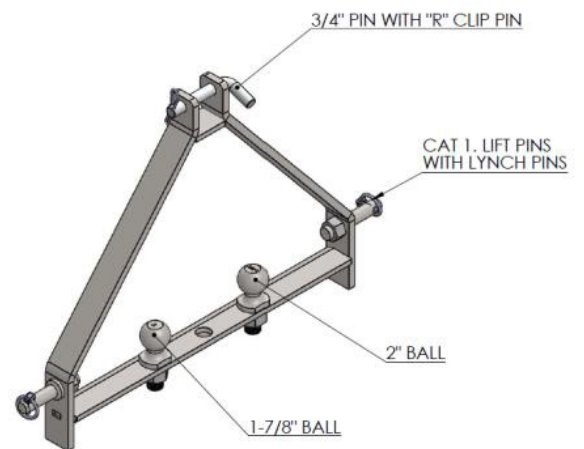

3 POINT

CATEGORY 1 - 3 POINT LANDSCAPE RAKE

60" Model #44009 • 72" Model #44012



- Standard Category 1 attachment
- 7 positions to give you complete control
- Top 3rd link has positions for float or static
- Durable, dependable and built to last Italian spring tooth tines
- Painted using a 2 part Urethane Process for an exceptional finish
- **Available in Red, Green or Black (Add -R, -G or -B after part number when ordering for color choice)**

SPECIFICATIONS

Overall Width	60", 72"
Depth	43"
Overall Height	36.25"
3Point Attachment Frame	5/16" - Grade 50
Tube	3" x 3" x 3/16"
Material	Grade 50 Steel
Weight	60" = 207 lbs, 72" = 255 lbs



MOUNTING PLATES

U-Style Model #33000 • V-Style Model #33005
Solid Style Model #33031 • 2 Piece Model #33043

SPECIFICATIONS

U-Style Model 33000	58 lbs
V-Style Model 33005	74 lbs
Sold Style Model 33031	85 lbs
2 Piece (L & R) Model 33043	41 lbs

- Update old attachments or build your own
- Fits all loaders and skid steers with universal quick-attach hitches
- Unpainted for easy welding



U-Style Model #33000



V-Style Model #33005



Solid Style Model #33031

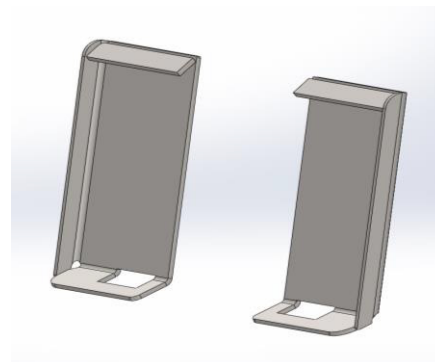

2 Piece Model #33043

MOUNTING PLATES

MISC. MOUNTING PLATES

Euro Style Plates 2 Piece Model #33229

Euro Style Plate Model #33219

JD 400/500 Series Kit (Offset Style) Model #33228

JD 400/500 Series Kit (Flat Style) Model #33199

RC-30/PT-30 Model #33130

SPECIFICATIONS

Euro Style 2 Piece Model 33000	46 lbs
Euro Style 33219	86 lbs
JD Offset Style Model 33228	40 lbs
JD Flat Style Model 33199	26 lbs
RC-30/PT-30 Model 33130	53 lbs

- Update old attachments or build your own
- Fits all loaders and skid steers with universal quick-attach hitches
- Unpainted for easy welding

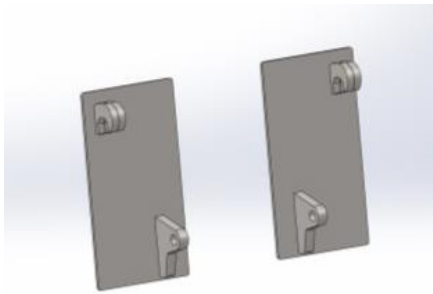

Euro Style Plates 2 Piece Model #33229

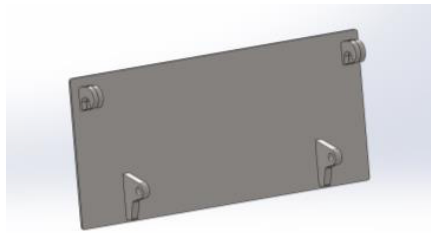

Euro Style Plate Model #33219

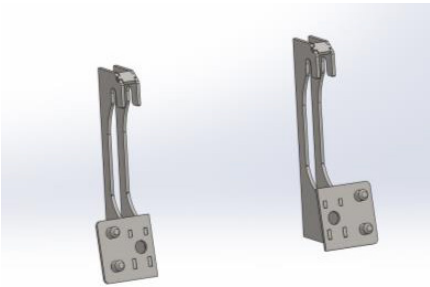

JD 400/500 Series Kits (Offset Style)
Model #33228

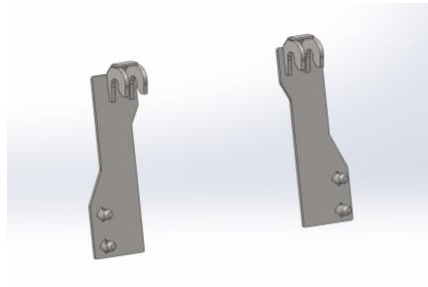

JD 400/500 Series Kits (Flat Style) Model
#33199

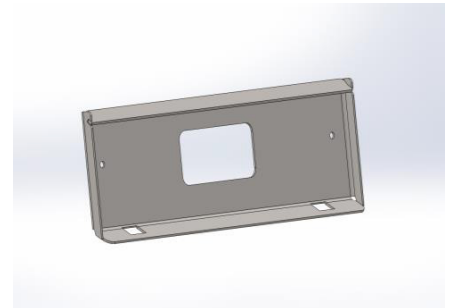

RC-30 / PT-30 Model #33130

MISC. MOUNTING PLATES

Toro Dingo Model #33182

Euro-Bale Accumulator Model #33201-Euro

U-Style Accumulator Mount Assembly Model #33201B

JD 400/500 Bale Accumulator Mount Assembly Model #33201-JD

Euro-Global Quick Attach Adapter Model #33334

Bobcat 440, 440B, 443, 444 Model #33304

SPECIFICATIONS

Toro Dingo Model 33182	30 lbs
Euro-Bale Accumulator Model #33201-Euro	114 lbs
U-Style Accumulator Mount Assembly Model #33201B	89 lbs
JD 400/500 Bale Accumulator Mount Assy. Model #33201-JD	114 lbs
Euro-Global Quick Attach Adaptor Model #33334	165 lbs
Bobcat 440, 440B, 443, 444 Model #33304	31 lbs

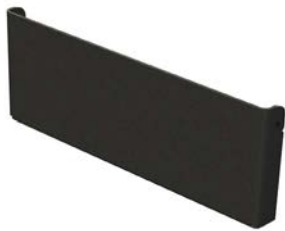

Toro Dingo Mounting Plate Model # 33182



Euro - Bale Accumulator Mounting Plate Model # 33201-Euro



U-Style Bale Accumulator Mount Assembly Model # 33201B



JD 400/500 Bale Accumulator Mount Assembly Model # 33201-JD



Euro-Global Quick Attach Adapter Model # 33334



Bobcat 440, 440B, 443, 444 Model #33304

3 POINT ADAPTER

3 POINT ADAPTER

Model #33280

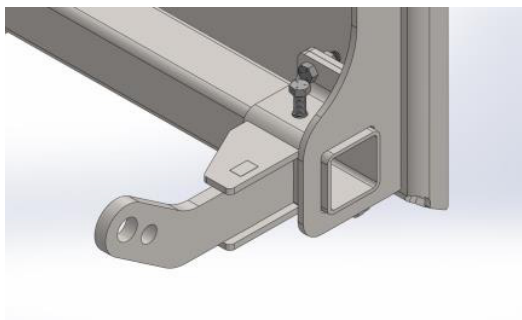
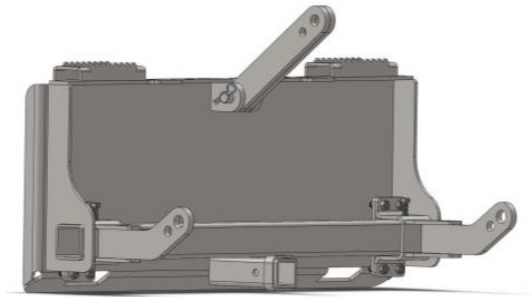

- Universal Skid Steer Mount with Cat. I and II Adapters plus additional Receiver Hitch
- Easily adapt 3 Point Tractor Attachments to Skid Steer
- Durable, dependable and built to last
- Painted using a 2 part Urethane Process for an exceptional finish

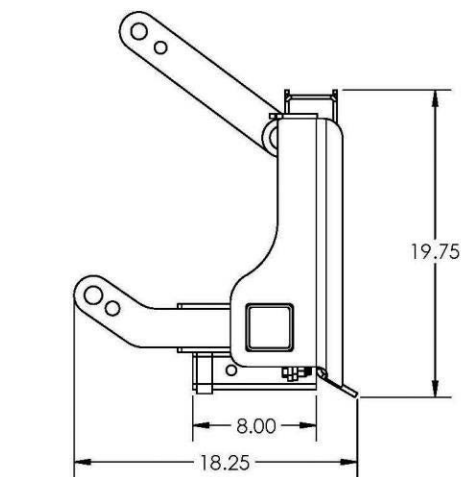
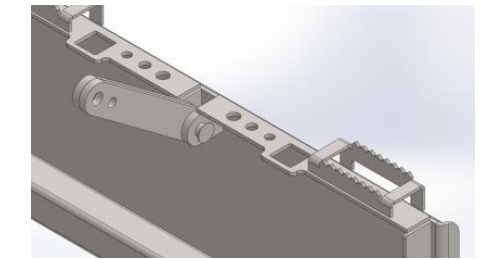

SPECIFICATIONS	
Overall Width	18.25"
Depth	8"
Overall Height	19.75"
Mounting Plate	5/16" - Grade 50
Tube	3" x 3" x 3/16"
Link Plates	5/8" - Grade 50
Weight	175 lbs

UNIVERSAL ADAPTER

UNIVERSAL QUICK ATTACH ADAPTER

Model #33054



- Easily convert Pin On Style Loaders to Universal Skid Steer Style
- Greaseable Pin and Bushing
- Durable, dependable and built to last
- Slim design keeps attachment close to machine

SPECIFICATIONS

Overall Width	44.125"
Depth	4"
Overall Height	16.875"
Bracket Height	16.875"
Bracket Width	9"
Tube	2" x 5" x 1/4"
Handle	3/8" - Laser Cut Grade 50
Weight	104 lbs

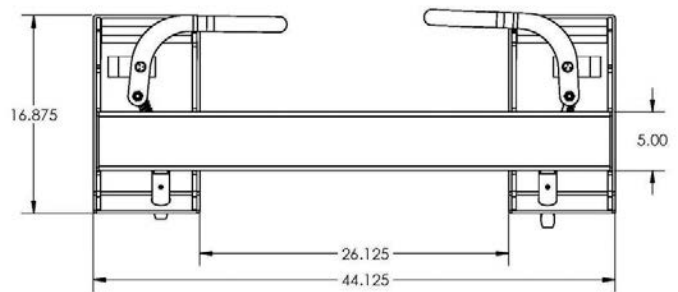

RECEIVER PLATE

Model #33015



SPECIFICATIONS

Width	45.75"
Depth	14"
Height	18"
Mounting Plate	5/16" - A-36 Steel
Gusset	1/4" - A-36 Steel
Top Bar	3/8" - A-36 Steel
Tube	2 1/2" Seamless Tube, Accepts a 2" Receiver Tube
Weight	105 lbs

Max. Lift Capacity - 1000 lbs

If you are constantly needing to move equipment quickly and easily from one place to another, or if you need to hook up to the truck every time you need to move a trailer around, this Receiver Hitch is the attachment you are looking for.

Hook up to this quick attach unit and let your skid loader do the work for you. This hitch allows you to quickly and easily guide equipment to where you need to without the inconvenience of hooking it up first. Works with any trailer, including goosenecks.

RECEIVER PLATE ACCESSORIES

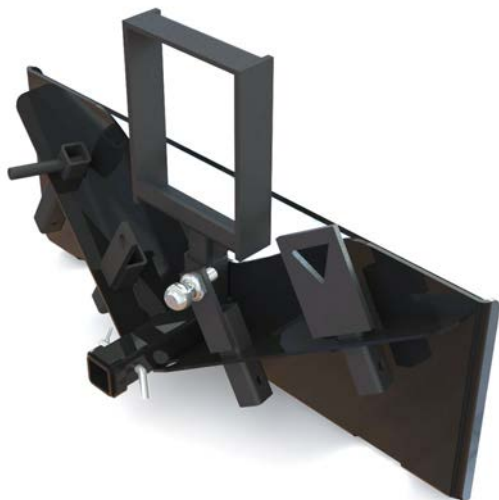

SPECIFICATIONS

Model #	Description	Weight
33161-50	Large Post Puller	26 lbs
33161-51	Hitch with Rod	6 lbs
33161-52	Ball Hitch (No Ball)	5 lbs
33161-53	Small T-Post Puller	8 lbs
33161-54	Tree Puller	24 lbs
10322	5/8" Receiver Pin	.75 lbs

Accessories are designed for use with our receiver plate only, 1000 lb lift capacity. Lift limit is determined by receiver capacity or loader capacity, whichever is less.

BOLT-ON CUTTING EDGE

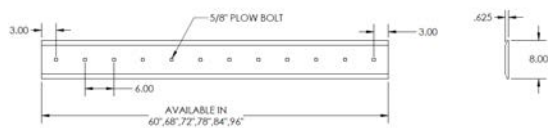
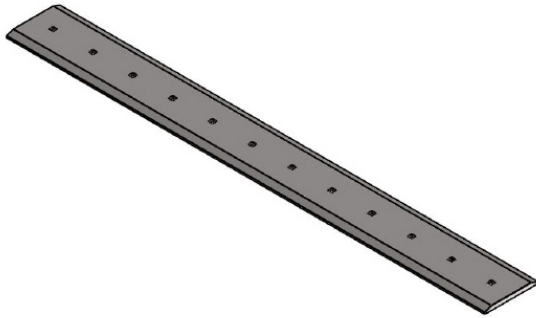

- 5/8" 8" double bevel Grade 1080

BOLT-ON TOOTH BAR

60" Model #33208 • 68" Model #33209
 72" Model #33039 • 78" Model #33210
 80" Model #33211 • 84" Model #33164



- Excellent tool for loosening compacted soil or grubbing out rocks
- Adaptable to most tractor and skid steer loader buckets
- An economical and convertible alternative to bolt-on or weld-on individual teeth
- Replacement teeth available

SPECIFICATIONS

Model	Description	Weight
33193	60" / 10 Hole	80 lbs
33194	68" / 11 Hole	91 lbs
33050	72" / 12 Hole	96 lbs
33201J-07	78" / 13 Hole	105 lbs
33051-80	80" / 13 Hole	107 lbs
33051	84" / 14 Hole	112 lbs
33052	96" / 16 Hole	128 lbs
33230	102" / 17 Hole	136 lbs
33231	108" / 18 Hole	144 lbs

SPECIFICATIONS

Designed for buckets with 3/4" thick cutting edge
 Fits all Legend Attachment Buckets. For all other bucket models,
 specify inside bucket width when ordering.

Overall Width	Varies by Bucket Width
Overall Depth	12.25"
Material	Grade 50 Steel
Weight	60" = 81 lbs, 68" = 92 lbs, 72" = 97 lbs 78" = 105 lbs, 80" = 108 lbs, 84" = 114 lbs

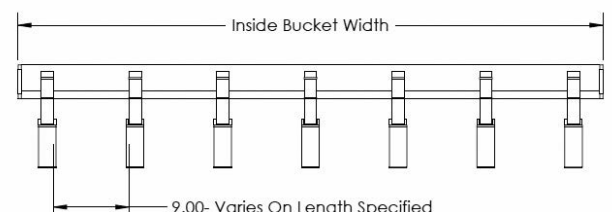
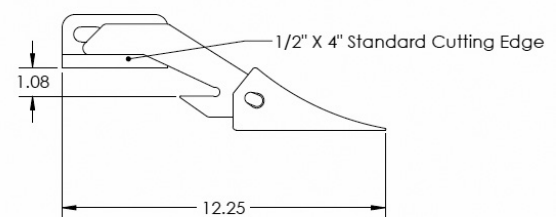

LEGEND ATTACHMENTS



Rev. 12/19

Legend Attachments Performance Guarantee

We offer the only true Performance guarantee in the industry. If your serial numbered attachment fails because of defects in material or workmanship, under normal working conditions in a 12 month period we will replace it at no charge. This warranty does not cover replacement of scheduled service items and high wear items.

Products and specifications are subject to change at any time.