

OWNER'S MANUAL

X-ROCK

www.x-rock.co.uk

instagram: [xrock_sup](https://www.instagram.com/xrock_sup)



XROCK_SUP

320x80x15cm **X-ROCK ARUBA**

ALL-AROUND INFLATABLE STAND UP PADDLE BOARD



X-ROCK

www.x-rock.co.uk

instagram: [xrock_sup](https://www.instagram.com/xrock_sup)

DEAR CUSTOMER:

Congratulations on your purchase of a **X-ROCK ARUBA** Inflatable Stand Up Paddle board. We are proud of providing the brilliant product to our customers around the world. Your new item is an investment which deserves your care and attention. This manual has been compiled to help you to operate your product with safety and pleasure.

The manual contains the following information:

- . Content of the package.
- . Product details
- . Assembly and disassembly
- . Operation instruction
- . Troubleshooting
- . Warranties

To ensure safety and prevent tragic accidents, please read it carefully and familiarize yourself with the product before using it.

The cautions and warnings below are advisories relative to various types of situations.

Please read them before you use the product.

CAUTION!

DENOTES AN IMMINENT HAZARD WHICH WILL RESULT IN SEVERE INJURY IF YOU DO NOT COMPLY WITH THE INSTRUCTIONS.

WARNING!

WARNING! REMINDS YOU OF SAFETY MEASURES WHICH MUST BE OBSERVED. DENOTES ALSO UNSAFE PRACTICES WHICH COULD RESULT IN INJURY OR PRODUCT OR PROPERTY DAMAGE IF YOU DO NOT COMPLY WITH THE INSTRUCTIONS.

GENERAL SAFETY

Stand up paddling can be physically demanding and dangerous in certain conditions. Users of this product should also understand that you may be seriously injured during the stand-up paddling if you not following all the safety precautions. Always obey all applicable watercraft laws and common sense.

SAFETY CHECKLIST

- Always paddle in safe conditions.
- Always wear a leash attaching you to the board.
- **Always wear a coast guard approved personal flotation device (PFD).**
- Always paddle with others.
- Avoid paddling in off shore winds or windy conditions.
- Be sure not to exceed your paddling ability and beware of your limits.
- Be aware of changing weather conditions.
- Do not use alcohol or mind-altering drugs while using this product.
- Never use this product in dark without proper lighting.
- Never let a minor use the board without adult supervision.
- Before going on a long paddle, be sure to inflate your board 24 hours prior to using it to make sure your board is airtight.

WARNING!

IT IS THE OWNER'S RESPONSIBILITY TO MAKE SURE THAT ALL USERS WILL CAREFULLY READ AND FOLLOW THE MANUAL AND INSTRUCTIONS FOR THE SAFE OPERATION OF THIS PRODUCT. OBSERVE ALL LOCAL AND NATIONAL LAWS.

X-ROCK

www.x-rock.co.uk
instagram: [xrock_sup](#)

IN THE PACKAGE

- One inflatable stand up paddleboard
- One 3-piece adjustable shaft fiber glass paddle
- One removable Quick Lock tool-less fin set
- One inflate/deflate double action hand pump
- One 10 ft coiled leash
- One storage and carry backpack
- One repair kit (glue is to be purchased separately)

TECHNICAL SPECIFICATION

MODEL	LENGTH	WIDTH	THICKNESS	WEIGHT	VOLUME	LOAD
320x80x15CM	10.6FT/320CM	31IN/80CM	6IN/15CM	18.7LB/8.5KG	275 L	297LB/135 KG



① CARRY HANDLES

② BUNGEE CORD

③ D-RINGS

④ EVA PAD

⑤ AIR VALVE

⑥ CENTER FIN

⑦ SIDE FIN

X-ROCK
www.x-rock.co.uk
 instagram: xrock_sup

ASSEMBLY/DISASSEMBLY

WARNING!

DO NOT USE SHARP TOOLS!

ANY USE OF AIR COMPRESSORS WILL DAMAGE YOUR PRODUCT AND VOID ALL WARRANTIES.

FOR FIRST INFLATION, IT IS RECOMMENDED TO INFLATE INDOOR AT ROOM TEMPERATURE WHERE THE BOARD MATERIAL IS SOFT AND THE ASSEMBLY PROCESS IS EASIER.

Choose a smooth and clean surface to unfold your product.

INFLATION

1) The board is equipped with a high-pressure valve. To inflate, first open the cap by turning it counterclockwise. Check and make sure the valve is in closed position. To verify that, push the pin down. If the pin stays down, you have now opened the valve. To close it, push the pin again so it springs back up. Now the valve is closed. Inflation is done in the CLOSED position (pin UP), and deflation is done in the OPEN position (pin DOWN).

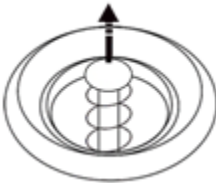

PIN UP- VALVE CLOSED

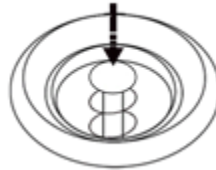

PIN DOWN- VALVE OPEN

2) The pump has two ports: the OUT port and the IN port on the handle. The OUT port is for inflation, and the IN port is for deflation. Attach one end of the pump hose to the OUT port, and the other end to the high-pressure valve. Push the hose fitting into the valve and turn clockwise to lock the position. Inflate until the desired pressure is reached the recommended pressure (12 to 15 psi). After inflation, disconnect the hose and close the cap. The valve won't be airtight until the valve cap is closed.

3) Read the instructions on the pump body about single action pumping and double action pumping. First pump in double action mode to generate large volume of air at low pressure. When you feel pumping becomes heavy, switch to single action and inflate to the desired pressure. Check board pressure with the gauge on the pump. Do not over-inflate the board. The recommended pressure for typical use is 12 to 15 psi.

FIN INSTALLATION

After inflation, install the center fin on the bottom of the board. Insert the one side of the fin into the box (a), and then push the fin into the box to make sure it's fully inserted. After the fin is completely install into the box, put the small insert into the opposite groove for fixing (b).



(a)



(b)

X-ROCK

www.x-rock.co.uk

instagram: [xrock_sup](https://www.instagram.com/xrock_sup)

PADDLE ASSEMBLY

The paddle consists of 3 sections: the handle, the shaft, and the blade. The shaft is symmetric, so it doesn't matter which end connects to the blade. To connect the blade and the shaft, first open the clip on the buckle. Align the spring ball on the blade with the lock hole on the shaft, then insert the blade into the shaft and make sure the spring ball locks in the hole (a). Close the clips on the buckle to secure the connection. For the handle there is no spring ball. Simply use the buckle to secure the handle. If the buckle becomes loose, open the clip and rotate clockwise to tighten the connection (b).

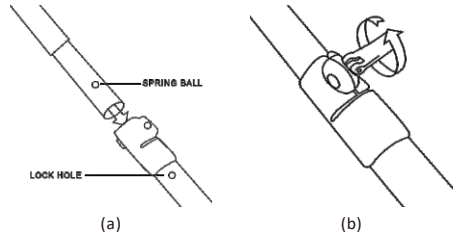

LEASH INSTALLATION

Affix one end of the leash to the back d-ring on the board, and the other end to your body.

WARNING!

ALWAYS WEAR A LEASH WHEN PADDLING!

DEFLATION

- 1) To deflate, open the valve cap and push the valve pin down to open the high-pressure valve.
- 2) After most air has emitted, use the pump to extract the remaining air. To do so, attach one end of the pump hose to the IN port, and the other end to the high-pressure valve. Pump till the board is fully deflated, detach the hose, push the valve pin to close the valve, and then close the cap.

CAUTION!

IF THE BOARD IS EXPOSED TO THE HOT SUN, CHECK THE PRESSURE AND MAKE SURE IT'S NOT OVERPRESSURED. DEFLATE SLIGHTLY IF NECESSARY.

STORAGE

- 1) Clean and check the board and all the accessories after each use. Rinse it thoroughly with clean water and make sure to remove any residues or salt if used in salt water. Do not use detergents or any type of silicone-based products. Make sure the product is completely dry before putting away.
- 2) Roll it up from the tail. put it into the backpack. Rolling from the tail can contain the fin boxes and clips inside the wrap, which will provide better protection than exposing them to the outside.
- 3) When storing your board, keep it in a clean and dry place that is not affected by major variations in temperature and other damaging factors. You may store it, deflated and rolled up in a bag or assembled and lightly inflated (not subject to deformations). Store it away from rodents.

CAUTION!

DO NOT STORE THE BOARD AT A TEMPERATURE BELOW 0 °C / 32 F . IT WILL DETERIORATE THE MATERIAL AND CAUSE PERMANENT DAMAGE.

X-ROCK

www.x-rock.co.uk

instagram: [xrock_sup](https://www.instagram.com/xrock_sup)

OPERATING INSTRUCTIONS

WARNING!

BEWARE OF OFFSHORE WINDS AND CURRENTS!
GET INFORMED ON LOCAL REGULATIONS AND HAZARDS RELATED TO THIS SPORT OR WATER ACTIVITIES.
LEARN ABOUT YOUR PADDLING AREA. ASK LOCALS ABOUT TIDES AND CURRENTS.
BEFORE USING THE PRODUCT, PLEASE CHECK CAREFULLY ITS FULLY FUNCTIONAL.
BE CAREFUL THAT YOU DO NOT OVERESTIMATE YOUR STRENGTH, YOUR ENDURANCE OR YOUR SKILL.
BE CAREFUL NEVER TO UNDERESTIMATE THE FORCES OF NATURE.
DO NOT EXCEED THE DESIGNED CAPACITY. AVOID ALL CONTACT BETWEEN THE BUOYANCY TUBES AND SHARP OBJECTS OR AGGRESSIVE LIQUIDS (SUCH AS ACID).
THIS PRODUCT IS DELIVERED WITH A BACKPACK. KEEP IT AWAY FROM CHILDREN. DANGER OF SUFFOCATION!

GENERAL PADDLING INFORMATION

The following are general steps to start paddling:

- 1) For the most comfortable start, choose a flat water location without too much wind, current or tidal movement.
- 2) Push board out onto water until fins can't touch the bottom, usually knee deep.
- 3) Most people start with kneeling on the board. Hold the paddle in the middle while blade angled to the rear. Take 2 small strokes then swap paddle to the other side and take two more.
- 4) Once you feel comfortable, try stand up. Place one foot on each side of the center of the board, shoulder width apart. If standing up makes you feel nervous, you can knee down and try again.
- 5) After standing up, soften your knees and tighten your core for balance.
- 6) Pull your top arm towards your body to extend the paddle forward. Insert paddle into the water as far forward as possible and bury the paddle into the water. Remove from water by rotating in as paddle comes in line with your body.
- 7) To make a wide turn keep paddling on one side without switching. To make a narrow turn place your paddle near the tail of the board and pull forward whilst shifting your torso to the desired direction.

SOME TIPS FOR BEGINNERS

- Look forward horizontally. Do not look into the water.
- Keep paddling. Your paddle is another supporting point for keeping balance.
- When adjusting your paddle, make the handle 9" or armlength overhead.

X-ROCK

www.x-rock.co.uk
instagram: [xrock_sup](https://www.instagram.com/xrock_sup)

TROUBLESHOOTING

PUMP NOT INFLATE/GAUGE NOT REGISTER

1. There are two ports on the pump, IN and OUT. Make sure you use the OUT port on the handle to inflate.
2. Do not bend too much when connecting the pipe to the valve, otherwise the pipe will easily fall off the valve. Please try to keep the vertical connection.
3. Check the pump gauge. Make sure the hose is detached. Pull up the pump handle. Block the OUT port with one hand, and then push the handle down with the other hand. You should feel resistance, and the gauge pointer should move. If you don't feel resistance, then the pump is leaking air. If you feel resistance, but the pointer does not move, the gauge is defective.

FIN FALL OFF

- 1) Press the clip down fully to lock the fin.
- 2) There is a screw underneath the clip. Tighten the screw to secure the installation.

LEAK

1) HIGH PRESSURE VALVE LEAKING

If the board is losing pressure check the board for leaks starting with the high-pressure valve, inflate the board to around 7 psi and spray the valve area with water, Check and see if there are air bubbles.

If leak is identified, deflate the board (a) and tighten the valve using the supplied wrench in the repair kit, Insert the wrench into the valve and rotate clockwise (b), After tightening, Inflate the board to check if leaking is fixed.

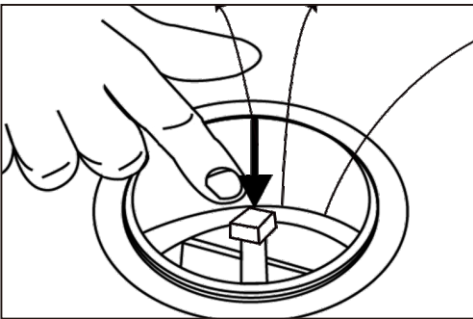

(a)

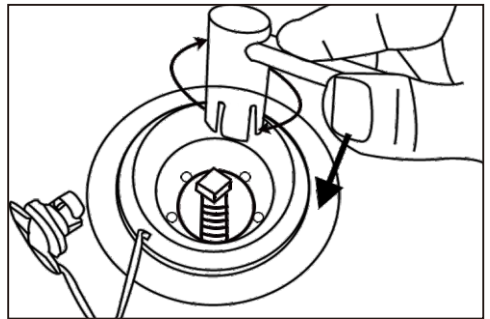

(b)

If tightening the valve does not fix leaking, the valve needs to be replaced. Take out the defective valve using the wrench to rotate counterclockwise. Install a new valve and check if leaking is fixed.

2) SMALL PUNCTURE LEAKING

If leak is not found at the valve, you may have a small puncture.

Small punctures-can be easily found by spraying all around the board to see where air bubbles become visible. If you can't find any bubbles, inflate the board to 15 psi and listen for an air leak. Note that for the repair to be successful, the humidity level should be less than 60%, temperature between 18°C/25°C or 65F/77F . Avoid carrying out repairs in the rain or in direct sunlight.

- 1) Draw the shape of the patch exactly where it will be applied, cut a round patch at least 1 cm/1/2" larger than the cut/damaged area.
- 2) Clean the damaged area and the corresponding side of the patch with a grease remover and allow it to dry for 5 minutes.
- 3) Apply 3 thin layers of glue on both the damaged area and the patch and allow each layer to dry for 5 minutes until the glue feels tacky.

X-ROCK

www.x-rock.co.uk

instagram: [xrock_sup](https://www.instagram.com/xrock_sup)

4) When the third layer of glue is dry, apply the patch without pressing and adjust the positioning if required. Press the air bubbles which may have formed under the patch by smoothing the patch with a round object such as a spoon. Do this procedure by starting in the center of the patch towards the outside. Clean any excess glue. Drying: 12 hours.

WARNING!

YOUR PRODUCT IS DESIGNED IN ACCORDANCE WITH THE STANDARDS FOR A SPECIFIC USE. ANY MODIFICATIONS OR EXCESSIVE USES COULD RESULT IN SERIOUS RISKS FOR THE USER AND WILL VOID THE WARRANTY.

X-ROCK offers 1 year Manufacturer Limited Warranty on the board (excluding attachments and other accessories in the package) to the original owner from the date of purchase. We guarantee against any abnormal defect in workmanship and materials within this period. Cosmetic issues such as paint fading, and any customer-initiated modifications to the product are not covered by warranty.

X-ROCK shall not be held liable for incidental and consequential damages. If the board is found to be defective, the owner may return it to the store it was purchased from with the original sales receipt. **X-ROCK** shall not be responsible for any damage or lost during transport. After inspection, **X-ROCK** reserves the right to either have the defective part or product professionally repaired, or replaced with an equivalent product.

This warranty commitment does not cover claim conditions listed below:

- Boards purchased in used condition.
- Boards used in rental, commercial, or teaching environment.
- Damage or defects caused by impact with any materials or objects such as rocks, docks, other boards, etc.
- Damage or defects caused by use outside of its intended purpose.
- Damage or defects caused by normal wear and tear.
- Damage or defects caused by transport, loading, unloading, dropping, or out of water handling. Including marks left by over tightening transport straps.
- Damage or defects caused by heel dents also known as pressure dings.
- Damage or defects caused by inappropriate storage in temperatures over 32°C / 90F and under 0°C / 32F.
- Damage or delamination caused by overheating as a result of exposure to direct sunlight while not in use.
- Damage or defects caused by wave impact and/or impact with ocean/lake floor.
- Damage or defects caused by storage of the board in closed, damp conditions (example a wet board bag).
- Damage to fin or fin box caused by impact to the fin.

For more information about **X-ROCK**, please visit our website:

www.xrock.co.uk

WARNING!

YOUR PRODUCT IS DESIGNED IN ACCORDANCE WITH THE STANDARDS FOR A SPECIFIC USE. ANY MODIFICATIONS OR EXCESSIVE USES COULD RESULT IN SERIOUS RISKS FOR THE USER AND WILL VOID THE WARRANTY.

X-ROCK
www.x-rock.co.uk
instagram: [xrock_sup](https://www.instagram.com/xrock_sup)