

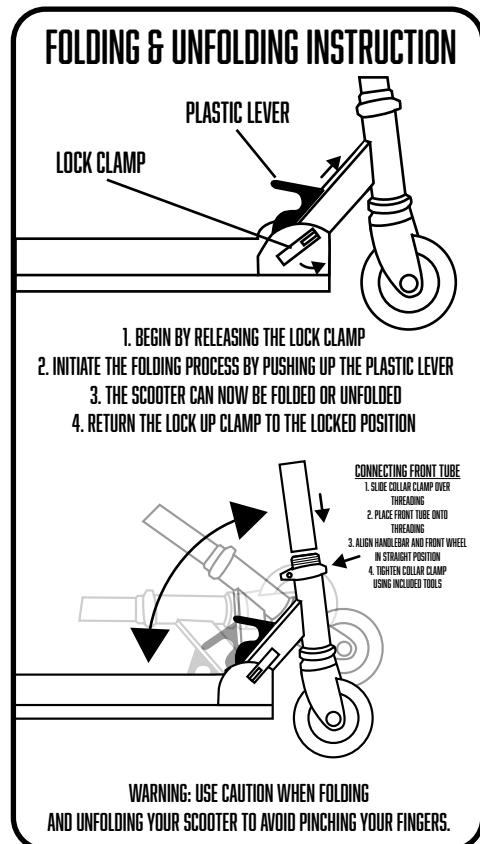

# INLINE SCOOTER INSTRUCTION MANUAL

PLEASE READ MANUAL BEFORE USE • ADULT ASSEMBLY REQUIRED

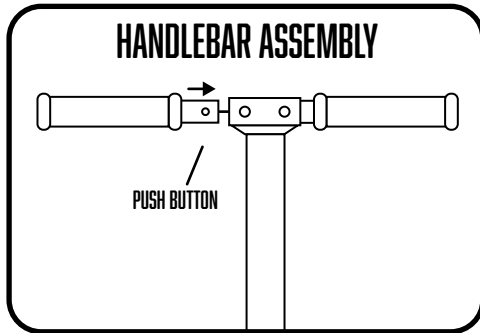

\*IF SCOOTER DOESN'T HAVE HEIGHT ADJUST FEATURE, SKIP STEP BELOW

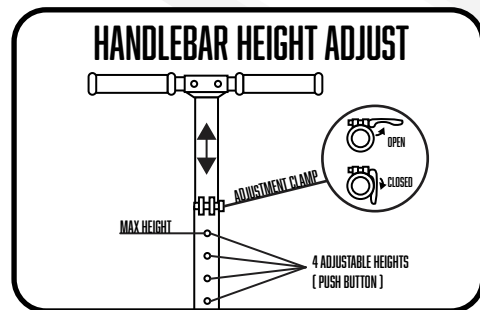

## WARNING!

- NOT SUITABLE FOR CHILDREN UNDER 60 MONTHS.
- CHOKING HAZARD DUE TO SMALL PARTS.
- USE ONLY UNDER CONSTANT ADULT SUPERVISION.
- SCOOTER MUST ONLY BE USED BY ONE RIDER AT A TIME.
- ALWAYS WEAR SAFETY EQUIPMENT SUCH AS CPSC APPROVED HELMET, KNEE PADS AND ELBOW PADS.
- ALWAYS KEEP CHINSTRAP SECURELY BUCKLED.
- ALWAYS WEAR FULLY ENCLOSED SHOES.
- DO NOT USE SCOOTER AT NIGHT.
- AVOID STREETS AND SURFACES WITH WATER, SAND, GRAVEL, DIRT, LEAVES AND OTHER DEBRIS. WET WEATHER IMPAIRS TRACTION, BRAKING AND VISIBILITY.
- AVOID SHARP BUMPS, DRAINAGE GRATES AND SUDDEN SURFACE CHANGES. SCOOTER MAY SUDDENLY STOP.
- THIS SCOOTER IS NOT DESIGNED FOR OFF-ROAD USE.
- IT IS NOT RECOMMENDED THAT THE SCOOTER BE USED ON STEEP SLOPES OR AT HIGH SPEEDS.
- DO NOT USE THIS PRODUCT FOR JUMPING, STUNTS OR TRICKS.
- ALWAYS FOLLOW LOCAL TRAFFIC AND SCOOTER RIDING LAWS AND REGULATIONS .
- ALWAYS WATCH SURROUNDINGS FOR PEDESTRIANS, OTHER RIDERS, AND AUTOMOBILES.
- ALWAYS CHECK THE BRAKES BEFORE RIDING.
- NEVER HAVE YOURSELF PULLED OR TOWED.
- BRAKE WILL GET HOT FROM CONTINUOUS USE, DO NOT TOUCH AFTER BRAKING.
- ALWAYS CHECK ALL CLAMPING DEVICES AND WHEELS FOR TIGHTNESS BEFORE RIDING.
- NEVER RIDE THE SCOOTER WITHOUT TIGHTENING THE FOLDING MECHANISM AND WHEELS.
- ADULTS MUST ASSIST CHILDREN IN THE INITIAL ADJUSTMENT PROCEDURES TO UNFOLD SCOOTER, ADJUST HANDLEBAR AND STEERING TO HEIGHT, AND FINALLY TO FOLD SCOOTER.
- USE AT OWN RISK OF INJURY.



## MAINTENANCE!

- DO NOT LEAVE THIS PRODUCT IN HIGH TEMPERATURES.
- DO NOT LEAVE THIS PRODUCT IN EXTREME LOW TEMPERATURES.
- DO NOT LEAVE THIS PRODUCT IN INTENSE SUNLIGHT OR DUSTY AREAS.
- STORE IN A DRY PLACE.

NO MODIFICATIONS THAT COULD AFFECT OR LESSEN SAFETY SHOULD BE INTRODUCED. AN EXPIRY DATE IS UNDETERMINABLE FOR ALL COMPONENTS. RIDER MUST CHECK THE EFFICIENCY OF ALL COMPONENTS BEFORE RIDING. IF ANY COMPONENT IS LOOSE OR DAMAGED, IT MUST BE TIGHTENED OR REPLACED BEFORE RIDING.

TESTING STANDARD

F2264

WEIGHT CAPACITY

220 LBS

ALL PACKAGING IS RECYCLABLE

