

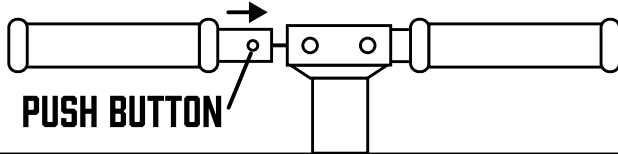

YOU MUST READ INSTRUCTION MANUAL PRIOR TO USE. ONLY USE UNDER ADULT SUPERVISION. USE AT OWN RISK.

HANDLEBAR



ASSEMBLY

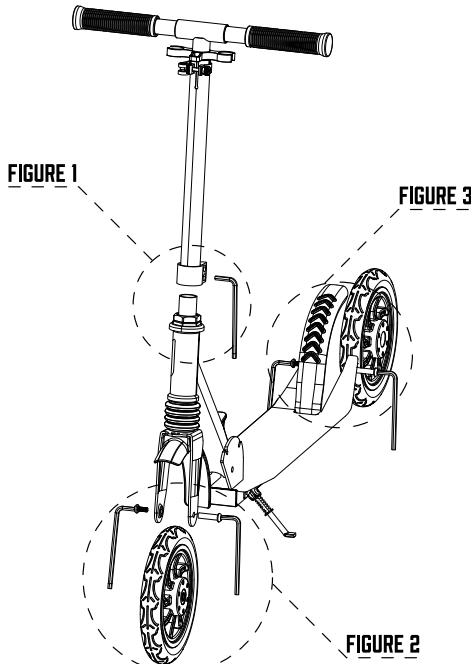
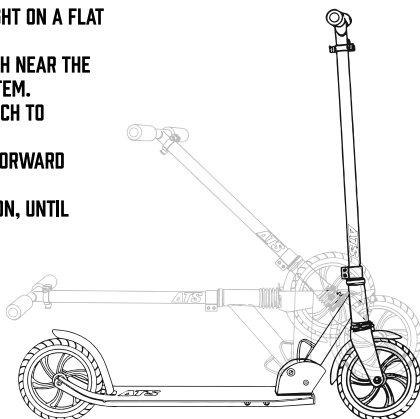

FIGURE 1 FRONT TUBE ASSEMBLY	FIGURE 2 FRONT WHEEL ASSEMBLY	FIGURE 3 BACK WHEEL ASSEMBLY
<p>STEP 1: INSERT THE FRONT TUBE -SLIDE THE FRONT TUBE DOWN INTO THE MAIN FRAME TUBE.</p> <p>STEP 2: ALIGN THE HOLES -ROTATE UNTIL THE HOLES OR ALIGNMENT MARKS LINE UP.</p> <p>STEP 3: TIGHTEN THE CLAMP -USE THE ALLEN KEY TO TIGHTEN THE CLAMP BOLT UNTIL SNUG (TUBE SHOULD NOT TWIST).</p>	<p>STEP 1: POSITION THE WHEEL -PLACE THE FRONT WHEEL BETWEEN THE FRONT FORKS.</p> <p>STEP 2: INSERT AXLE BOLT -SLIDE THE AXLE THROUGH BOTH FORK ENDS AND THE WHEEL HUB.</p> <p>STEP 3: SECURE WITH NUTS -TIGHTEN BOTH SIDES EVENLY WITH THE ALLEN KEYS UNTIL THE WHEEL SPINS FREELY BUT DOES NOT Wobble.</p>	<p>STEP 1: PLACE WHEEL INTO REAR FRAME -ALIGN THE REAR WHEEL WITH THE MOUNTING SLOTS ON BOTH SIDES.</p> <p>STEP 2: INSERT AXLE BOLT -SLIDE THE REAR AXLE THROUGH THE FRAME AND WHEEL HUB.</p> <p>STEP 3: TIGHTEN EVENLY -USE THE ALLEN KEYS TO SECURE BOTH SIDES. MAKE SURE WHEEL IS CENTERED.</p>

FOLDING

1. STAND THE SCOOTER UPRIGHT ON A FLAT SURFACE.
2. LOCATE THE FOLDING LATCH NEAR THE BASE OF THE HANDLEBAR STEM.
3. PULL OR RELEASE THE LATCH TO UNLOCK THE STEM.
4. LOWER THE HANDLEBAR FORWARD TOWARD THE DECK.
5. LOCK INTO FOLDED POSITION, UNTIL SECURE.



CAUTION

INFLATE TIRES USING A MANUAL PUMP ONLY (NOT INCLUDED).
AVOID OVERINFLATION.

WARNING

- NOT SUITABLE FOR CHILDREN UNDER 60 MONTHS.
- CHOKING HAZARD DUE TO SMALL PARTS.
- USE ONLY UNDER CONSTANT ADULT SUPERVISION.
- SCOOTER MUST ONLY BE USED BY ONE RIDER AT A TIME.
- ALWAYS WEAR SAFETY EQUIPMENT SUCH AS CPSC APPROVED HELMET, KNEE PADS, AND ELBOW PADS.
- ALWAYS KEEP CHINSTRAP SECURELY BUCKLED.
- ALWAYS WEAR FULLY ENCLOSED SHOES.
- DO NOT USE SCOOTER AT NIGHT.
- AVOID STREETS AND SURFACES WITH WATER, SAND, GRAVEL, DIRT, LEAVES, AND OTHER DEBRIS. WET WEATHER IMPAIRS TRACTION, BRAKING, AND VISIBILITY.
- AVOID SHARP BUMPS, DRAINAGE GRATES, AND SUDDEN SURFACE CHANGES. SCOOTER MAY SUDDENLY STOP.
- THIS SCOOTER IS NOT DESIGNED FOR OFF-ROAD USE.
- IT IS NOT RECOMMENDED THAT THE SCOOTER BE USED ON STEEP SLOPES OR AT HIGH SPEEDS.
- DO NOT USE THIS PRODUCT FOR JUMPING, STUNTS, OR TRICKS.
- ALWAYS FOLLOW LOCAL TRAFFIC AND SCOOTER RIDING LAWS AND REGULATIONS.
- ALWAYS WATCH SURROUNDINGS FOR PEDESTRIANS, OTHER RIDERS, AND AUTOMOBILES.
- ALWAYS CHECK THE BRAKES BEFORE RIDING.
- NEVER HAVE YOURSELF PULLED OR TOWED.
- ALWAYS CHECK ALL CLAMPING DEVICES AND WHEELS FOR TIGHTNESS BEFORE RIDING.
- NEVER RIDE THE SCOOTER WITHOUT TIGHTENING THE FOLDING MECHANISM AND WHEELS.
- ADULTS MUST ASSIST CHILDREN IN THE INITIAL ADJUSTMENT PROCEDURES TO UNFOLD SCOOTER, ADJUST HANDLEBAR AND STEERING TO HEIGHT, AND FINALLY TO FOLD SCOOTER.
- AVOID SUDDEN BRAKING TO PREVENT LOSS OF CONTROL.
- USE AT OWN RISK OF INJURY.



MAINTENANCE!

- DO NOT LEAVE THIS PRODUCT IN HIGH TEMPERATURES.
- DO NOT LEAVE THIS PRODUCT IN EXTREME LOW TEMPERATURES.
- DO NOT LEAVE THIS PRODUCT IN INTENSE SUNLIGHT OR DUSTY AREAS.
- STORE IN A DRY PLACE.

CAUTION

NO MODIFICATIONS THAT COULD AFFECT OR LESSEN SAFETY SHOULD BE INTRODUCED.
AN EXPIRY DATE IS UNDETERMINABLE FOR ALL COMPONENTS.
RIDER MUST CHECK THE EFFICIENCY OF ALL COMPONENTS BEFORE RIDING.
IF ANY COMPONENT IS LOOSE OR DAMAGED, IT MUST BE TIGHTENED OR REPLACED BEFORE RIDING.

CUSTOMER SUPPORT
1 (800) 986-6415

VISIT WWW.HALORISEABOVE.COM
FOR MORE DETAILS
@ HALORISEABOVE

TESTING STANDARD
F2264

WEIGHT CAPACITY
220 LBS



Gillyboo
CORPORATION
124 CONNIE CRESCENT
CONCORD, ONTARIO, CANADA L4K1L7