



160MM WHEEL INLINE SCOOTER



PLEASE READ MANUAL BEFORE USE • ADULT ASSEMBLY REQUIRED

YOU MUST READ INSTRUCTION MANUAL PRIOR TO USE. ONLY USE UNDER ADULT SUPERVISION. USE AT OWN RISK.

ASSEMBLY

HOW TO FRONT TUBE

INSERT THE FRONT TUBE: SLIDE THE FRONT TUBE INTO THE BASE TUBE ON THE SCOOTER FRAME.

SECURE WITH CLAMP: TIGHTEN THE CLAMP USING THE PROVIDED ALLEN KEY (HEX WRENCH) UNTIL THE FRONT TUBE IS SECURED.

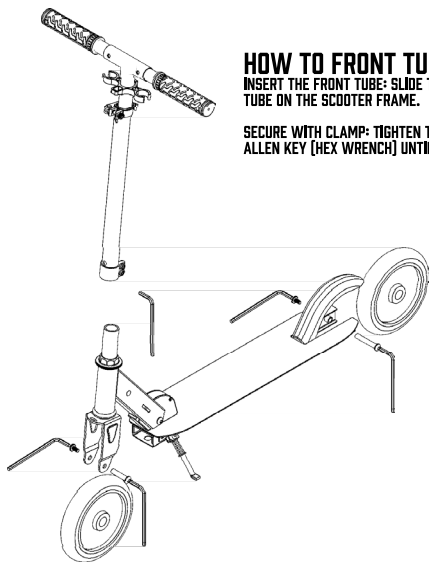

HOW TO ATTACH WHEELS

ALIGN WHEELS: POSITION THE FRONT AND BACK WHEELS BETWEEN THE FRAME ARMS OF THE SCOOTER.

INSERT AXLES: SLIDE THE AXLE BOLTS THROUGH THE HOLES IN THE FRAME ARMS, PASSING THROUGH THE WHEEL HUBS. ENSURE THE BOLTS ARE FULLY INSERTED.

SECURE WITH ALLEN KEYS: USE THE PROVIDED ALLEN KEYS (HEX WRENCHES) TO TIGHTEN THE AXLE BOLTS. MAKE SURE BOTH SIDES ARE EVENLY TIGHTENED FOR STABILITY.

CHECK AND ADJUST: SPIN BOTH WHEELS TO ENSURE THEY ROTATE FREELY WITHOUT WOBBLING. RE-TIGHTEN IF NEEDED.

SCOOTER FEATURES

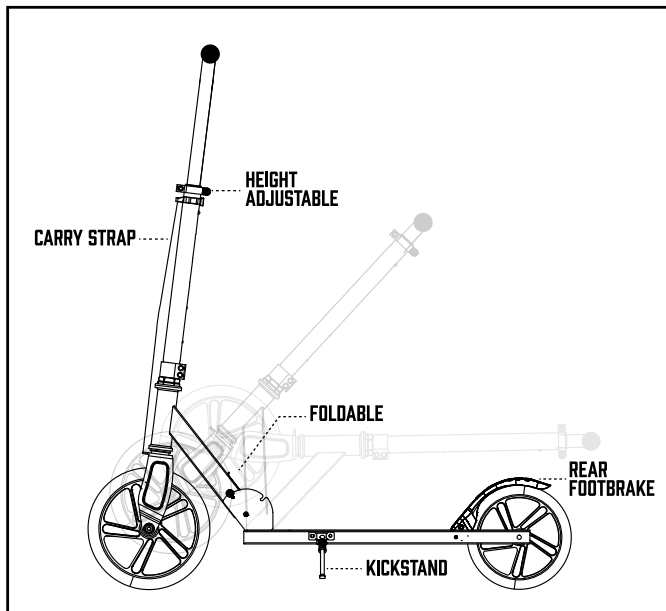

WARNING

- NOT SUITABLE FOR CHILDREN UNDER 60 MONTHS.
- CHOKING HAZARD DUE TO SMALL PARTS.
- USE ONLY UNDER CONSTANT ADULT SUPERVISION.
- SCOOTER MUST ONLY BE USED BY ONE RIDER AT A TIME.
- ALWAYS WEAR SAFETY EQUIPMENT SUCH AS CPSC APPROVED HELMET, KNEE PADS, AND ELBOW PADS.
- ALWAYS KEEP CHINSTRAP SECURELY BUCKLED.
- ALWAYS WEAR FULLY ENCLOSED SHOES.
- DO NOT USE SCOOTER AT NIGHT.
- AVOID STREETS AND SURFACES WITH WATER, SAND, GRAVEL, DIRT, LEAVES, AND OTHER DEBRIS. WET WEATHER IMPAIRS TRACTION, BRAKING, AND VISIBILITY.
- AVOID SHARP BUMPS, DRAINAGE GRATES, AND SUDDEN SURFACE CHANGES. SCOOTER MAY SUDDENLY STOP.
- THIS SCOOTER IS NOT DESIGNED FOR OFF-ROAD USE.
- IT IS NOT RECOMMENDED THAT THE SCOOTER BE USED ON STEEP SLOPES OR AT HIGH SPEEDS.
- DO NOT USE THIS PRODUCT FOR JUMPING, STUNTS, OR TRICKS.
- ALWAYS FOLLOW LOCAL TRAFFIC AND SCOOTER RIDING LAWS AND REGULATIONS.
- ALWAYS WATCH SURROUNDINGS FOR PEDESTRIANS, OTHER RIDERS, AND AUTOMOBILES.
- ALWAYS CHECK THE BRAKES BEFORE RIDING.
- NEVER HAVE YOURSELF PULLED OR TOWED.
- ALWAYS CHECK ALL CLAMPING DEVICES AND WHEELS FOR TIGHTNESS BEFORE RIDING.
- NEVER RIDE THE SCOOTER WITHOUT TIGHTENING THE FOLDING MECHANISM AND WHEELS.
- ADULTS MUST ASSIST CHILDREN IN THE INITIAL ADJUSTMENT PROCEDURES TO UNFOLD SCOOTER, ADJUST HANDLEBAR AND STEERING TO HEIGHT, AND FINALLY TO FOLD SCOOTER.
- AVOID SUDDEN BRAKING TO PREVENT LOSS OF CONTROL.
- ALWAYS ENSURE KICKSTAND IS FULLY RETRACTED BEFORE RIDING.
- USE AT OWN RISK OF INJURY.

MAINTENANCE!

- DO NOT LEAVE THIS PRODUCT IN HIGH TEMPERATURES.
- DO NOT LEAVE THIS PRODUCT IN EXTREME LOW TEMPERATURES.
- DO NOT LEAVE THIS PRODUCT IN INTENSE SUNLIGHT OR DUSTY AREAS.
- STORE IN A DRY PLACE.

CAUTION

NO MODIFICATIONS THAT COULD AFFECT OR LESSEN SAFETY SHOULD BE INTRODUCED. AN EXPIRY DATE IS UNDETERMINABLE FOR ALL COMPONENTS. RIDER MUST CHECK THE EFFICIENCY OF ALL COMPONENTS BEFORE RIDING. IF ANY COMPONENT IS LOOSE OR DAMAGED, IT MUST BE TIGHTENED OR REPLACED BEFORE RIDING.

TESTING STANDARD

F2264

WEIGHT CAPACITY

220 LBS



DO NOT CONTACT RETAILER!

FOR ALL CUSTOMER SERVICE ISSUES CONTACT:

GILLYBODCUSTOMERCARE@GMAIL.COM

OR VISIT

GILLYBODCORPORATION.COM/CONTACT-US



CUSTOMER SUPPORT
1 (800) 986-6415