



Charles W. Flanagan Senior High School
Navy Junior Reserve Officer Training Corps
12800 Taft Street
Pembroke Pines, FL 33028
754-323-0742



Dear Parents and Cadets,

1. Welcome to the Charles W. Flanagan High School (FHS) Navy Junior Reserve Officer's Training Corps (NJROTC) program. We are looking forward to a great year. Individual cadet grades are contingent upon performance in the following areas: academics, military proficiency skills, leadership, and summative assessments as outlined in the course syllabus. Cadets will participate in many extracurricular activities: Drill, Color Guard, Robotics, Raider Challenges, and other activities designed to enhance Leadership skills. Additional events include community service, fundraisers, and orientation trips. The NJROTC educational experience has a greater impact on cadets when they actively participate in unit activities. In order for the year to get off to a good start, we need your help with the following items:
2. Please read and sign the NJROTC Contract (2023-2024), Navy Junior Reserve Officer's Training Corps Program Syllabus, the Parent/Guardian Permission Form (2023-2024), the Release And Hold Harmless Agreement, the Assumption of Risk, Waiver, Release & Hold Harmless form, the Broward County Consent for Treatment, the Flanagan High School Code of Conduct Agreement, the BCPS Physical Form and return no later than _____ . All these documents will be kept in the cadet's NJROTC file for the entire year.
3. We expect all cadets to meet unit-grooming standards (haircuts, buns, shaves, nails, etc.).
4. For classroom instruction, cadets will need pencil/pen, highlighter, and a two-inch three ring binder with a small amount of loose-leaf paper. For Physical Training (PT) cadets will need a pair of running shoes, white or black socks, and a water bottle for hydration.
5. All of the requirements outlined above are expected to be met by the required due dates that purposely occur prior to the course drop date. Failure to comply may result in your student being dropped from the program.
6. All NJROTC cadets must pay a maintenance fee that will cover the cost of various essential items not provided by the NAVY. The maintenance fee is \$50.00. All items listed in the maintenance fee is yours to keep. This includes: one physical training shirt, one physical training short, all alterations to the uniform, and cleaning of the uniform before issued, green Falcon Battalion shirt, uniform name tag, shoe polish kit, and coverage under the NJROTC Flanagan Group Insurance Policy. Payment can be made online via the online store at <https://www.browardschools.com/osp>.
7. We are looking forward to teaming with you to make each cadet's experience in NJROTC a rewarding one. If you have any questions or concerns, please do not hesitate to contact the NJROTC instructional staff.

Semper Fidelis,

Captain Ibn Taylor
USMC (Ret.)
Senior Naval Science Instructor

NJROTC CONTRACT (2023-2024)

I, Cadet _____, agree and promise to comply with the following rules and regulations. If I do not, I understand that I may be dis-enrolled from the JROTC.

- I will obey the rules for Flanagan High School students as explained in the Student Handbook and the Cadet Handbook.
- I will treat others and other's property with respect.
- I understand that others will judge me by my conduct not just in the NJROTC but in all my classes. I will conduct myself as a gentleman/lady in all my classes. I understand that being bad behavior is a poor reflection on me, my school, and my unit and I will accept the consequences of my actions.
- I will wear my uniform properly on all prescribed occasions. I understand that, if I fail to wear the uniform on the prescribed occasions, I will receive a grade of "0" for that day and that frequent failure to wear my uniform may result in being dropped from the JROTC. I understand that I may change out of uniform for classes that require it (for example, PE), but will put the uniform back on before the end of that class.
- I will adhere to all grooming standards (to include hair regulations) outlined by the Navy JROTC.
- I will address the instructors by "Sir" or their rank and last name.
- I understand physical training (PT) is an important part of the NJROTC program and will bring my PT gear on the prescribed occasions. If I fail to do so, I will be given a grade of "0" for that day. I understand that frequent failure to bring my PT gear will result in being dropped from the JROTC program.
- I understand that my attendance in school is important to my learning experience and success. I agree to come to school regularly. Frequent absences will lead to losing credit for class and/or being dismissed from the JROTC program.
- I understand that as a cadet I will be required to do physical fitness training. This physical training will consist of individual and group effort. I will give 100% effort when participating in physical training.
- I understand that academic success is a primary goal of JROTC and agree to do my very best to be successful in all my courses, not just JROTC. If I am having problems in a class or classes, I will go to tutorials for help. I also understand that promotions are partly based on academic success. If I fail courses, I will not be promoted.
- I understand that giving back to the community is an important part of leadership. **I understand that I will be required to volunteer a minimum of five hours per quarter (twenty (20) hours of community service per year) for a grade.** This service can be with the JROTC sponsored functions or may be with other organizations (church, civic organizations, etc.) or projects I find on my own. For credit for my hours done with other organizations, I must bring proof of service from the organization(s).
- **I understand that as a cadet in the Flanagan NJROTC, that I will be required to be participant in at least one "official event/ceremony" each semester for a test grade.** Examples are Color Guard, Cake Cutting Ceremony, 911 Remembrance and or other events approved by the SNSI and NSI.

I have read the above contract. By my signature below, I agree to follow the rules of the school and JROTC. My parents have signed to indicate that they have also read this and agree to help me reach my goals.

→ _____
(Date)

(Cadet's Signature)

(Parent's Signature)

Navy Junior Reserve Officer's Training Corps Program Syllabus

Course Title:	Course Title: Naval Science Leadership Education I-IV
Course Name:	Naval Sciences, Navy Junior Reserve Officer's Training Corps (NJROTC)
Instructors:	Ibn A. Taylor Captain, USMC (Ret) Senior Naval Science Instructor ibn.taylor@browardschools.com
School Number	540-658-6840
Remind App	Class Name: NJROTC 2023-24 All cadets must join. <i>(This will be a classwork grade)</i> Parents are encouraged to join. To join: Text @4999cg to 81010 <i>or</i> https://www.remind.com/join/4999cg

Course Overview: The Navy Junior Reserve Officer's Training Corps (NJROTC) program is a Naval Sciences (NS) Leadership Education program designed to teach leadership skills, character development, self-discipline, and citizenship through the study and practical application of naval leadership traits and principles. The NJROTC program combines classroom instruction and practical application to achieve its objectives. At Flanagan High School, NJROTC is a four-year, four level, course which provides one credit for each year satisfactorily completed. Students are referred to as "Cadets" and will be issued a Naval uniform to wear once a week and will be expected to maintain Naval grooming standards. Cadets who excel in the program will also be promoted using a JROTC rank structure and will be offered positions in the Cadet Battalion Staff. *Lastly, this class is based on many military aspects, cadets have no obligation to join the military.*

Course Description: The NS curriculum focuses on the five NJROTC core content areas: Leadership, Citizenship, Personal Growth and Responsibility, Public Service and Career Exploration, and General Military Subjects. Given this, cadets receive specific classes in leadership, government, history, health and fitness, college and career opportunities, and drill and land navigation (see table below for topics by marking period). To further the learning process, there are also many extracurricular activities for cadets. These activities include Community Service; Drill, Color Guard, Cyber, Academic, Orienteering and Physical Training Teams; leadership camps; and social events.

Course Prerequisites:

- NS I -completion of the eighth grade.
- NS II-IV must successfully complete the previous NS program.

Course Objectives:

- Develop leadership, build character, and create informed and responsible citizens.
- Develop young adults who are physically, mentally, and morally fit.
- Develop civic-minded young adults prepared for both higher education and public service.
- Instill discipline, respect, and responsibility through military-related subjects and activities.

Special Information. This program consists of up to four levels of instruction. Students are required to enroll in this course for a complete school year; NJROTC is not available on a semester basis. Upon successful course completion, students will receive one credit per year.

Grading Policy. Students can earn points in the following disciplines:

1. **Academics.** Exams, discussion participation, and quizzes. All class work, to include homework, projects, tests, and all written assignments are to be completed on your own unless specifically directed otherwise by an instructor. Any cadet earning less than a C average should make arrangements with the instructor and parents to improve achievement.

2. **Leadership.** Cadets are expected to set a good example in personal behavior, military bearing, and academic performance. Cadets must maintain a 2.5 GPA to be promoted and retain Noncommissioned Officer (NCO) and Officer Ranks. Minor or major infractions will affect the cadet's grade as follows:

- a. Misbehavior/misconduct equates to the loss of 20/40 points of that day's graded event(s).

- b. In school suspension (ISS) and detention will result in a 50% reduction of that day's graded event(s).
- c. Out of school suspension (OSS) equates to the loss of 100 points of that day's participation grade.
- d. ISS/OSS and detention is an automatic reduction in rank.

3. **Uniform and Grooming.** All cadets will be required to adhere to naval grooming standards while enrolled in NJROTC. The Cadet NJROTC uniform will be worn for a quiz grade at minimum twice a month. It must be clean and freshly pressed. No more than two excused absences will be allowed for a designated uniform day each semester. Points are lost for discrepancies (to include bearing) while in uniform. Failure to wear the uniform on the prescribed day will result in a quiz grade of zero unless previously coordinated with the instructor.

4. **Official Events:** All a cadets will be required to be participant in at least one "official event/ceremony" each semester for a test grade. Examples: Color Guard, Cake Cutting Ceremony, 911 Remembrance and or other events approved by the SMI and MI.

5. **Physical Fitness.** Students must display effort to improve physical fitness.

6. NJROTC **grading policy** weight breakdown:

35% Tests	Academics (Uniforms, Rank, History, Leadership, Interior Guard/General Orders, Citizenship, etc.), Discussion Participation, and Physical Fitness Tests
25% Quizzes	Academic (at least weekly), Uniform/Grooming Inspections (every two weeks), Physical Training (weekly), and Drill (weekly)
20% Leadership/Conduct	Accountability of Uniforms (Utilities and PT)
20% Classwork	

7. Broward County Grading Scale:

<u>GRADE</u>	<u>RANGE</u>	<u>GRADE</u>	<u>RANGE</u>	<u>GRADE</u>	<u>RANGE</u>	<u>GRADE</u>	<u>RANGE</u>
A+	98-100	B+	87-89	C+	77-79	D+	67-69
A	93-97	B	83-86	C	73-76	D	63-66
A-	90-92	B-	80-82	C-	70-72	D-	60-62
						F	0-59

Overall Grade: Your overall participation grade will be determined by how you do in the above categories. Everything we will do this school year is designed for you to excel. If you are not wearing your uniform on a consistent basis and not participate in cadet led events, you will not meet the standard.

Late Work: Making up missed or late work is the responsibility of the cadet and NOT the teacher. The cadet, immediately upon his/her return from an absence, must check with his/her teachers for make-up work that may be due. All cadets should complete all assignments on time. When this does not occur, cadets are encouraged to complete all assignments even if they are late. The highest grade for late work is 75%.

- After two missed assignments in a two-week period, we will notify the parent/guardian via progress report, e-mail, or phone call.
- When a pattern of missed assignments is observed, we will contact the cadets' administrator and/or counselor for further intervention.

Re-Take Policy: All cadets have the opportunity to show mastery of content through reassessments on quizzes and other assessments given. In order for a reassessment to be provided, cadets will coordinate the taking of reassessment with one of the NJROTC Instructors and will complete any preparatory assignments associated with the assessment. Cadets who prepare and take reassessments are eligible to receive up to 90% for their grade.

Extra-Credit: Cadets may earn extra credit by completing additional content-based information on quizzes and writing assignments that reinforce and amplify learning objectives. Extra-Credit will be limited to 10 points out of 100 for each assignment.

Promotion. Promotions are an honor and a privilege that can be earned at regular intervals. Promotion is earned by demonstrated achievement in all program disciplines, successful execution of leadership assignment/billets, and demonstrated military growth and maturity. A cadet must pass the Initial Strength Test (IST), have/maintain a 2.0 GPA, work eight hours of community service at each rank, and be able to answer all rank appropriate questions outlined in the cadet handbook.

Community Service. These events are a hallmark of the NJROTC program. Cadets must complete a *minimum of five hours per quarter (20 hours of community service per year) for a grade.* Cadets are encouraged to participate in out of class service learning and community service projects. Cadets must provide 5 hours of community service each semester. Participation can earn you the NJROTC ribbons and the President’s Volunteer Service Award. As you can imagine, our busiest times of the year are around Veteran’s Day and Memorial Day. Please ensure you make yourselves available during these long weekends for community events.

Make-up Work. It is the cadet’s responsibility to communicate with the teacher on the day he or she returns to class to schedule the makeup of missed work. Cadets are expected to make up all work missed within a time period not to exceed the total number of days absent. Upon their return to class, cadets are expected to turn in any work that was due on the day(s) of absence which was previously assigned. Previously assigned work DOES NOT qualify for extended make-up time.

Academic Integrity: There will be absolutely no tolerance for cheating in any form. Cheating is giving or receiving unauthorized aid on any test, quiz, or assignment. It is important that cadets do their own work in order to maximize their learning.

Attendance: Class attendance and tardy issues will be handled in accordance with the Flanagan High School Attendance Policy. The majority of this course is performance based. Participation is at the core of what is expected of all cadets regardless of their years in the program. Therefore, cadets (cadets) must be present in order to be adequately evaluated. Unexcused absences & unexcused tardy’s will adversely affect an individual’s grade. Unexcused absences on Uniform and PT days will result in the cadet receiving “0” for that event, in addition to impacting their Leadership/Conduct grade.

DISENROLLMENT POLICY: The SNSI may disenroll a cadet from the NJROTC unit for any of the following reasons:

- Failure to maintain standards of enrollment.
- Lack of aptitude, indifference to training, disciplinary infractions, or undesirable traits of character.
- Disenrollment from school.
- Request of the individual cadet.
- If, in the opinion of the SNSI, the cadet would suffer undue hardship by remaining in the unit for any reason, then disenrollment is authorized.
- Found guilty of a misdemeanor or felony.

We understand that students learn in different ways. Therefore, each instructor will vary their teaching methods in order to best meet the needs of all students. In the rubric above, you can see how much interaction with other cadets plays a huge role in JROTC.

Differentiated Instruction

	Lecture	Peer to Peer	Cadet Led	Group Work	Individual
Subject Intro	70%		25%		5%
Acquire	20%	20%	20%	20%	20%
Gather	5%	15%	10%	30%	40%
Process	10%	20%	30%	30%	10%
Apply	20%	20%	10%	20%	30%

Critical Thinking and Mastery of Competencies

	Essays	Application	Explanation	Reflection	Group Work
		Scenario Based	Open ended Questions	Self- Application	Effective Team Work
Mastery of Subject	Grade A	Best	90% + Accurate	Well Thought Out	Vital part of the Team
Clear understanding of the Subject	Grade B	Good	80-90% Accurate	Clearly Applied	Important part of the Team
Basic understanding of the Subject	Grade C	Satisfactory	70-80% Accurate	Satisfactory	Contributes to the Team
Limited understanding of the Subject	Grade D	Needs Improvement	60-70% Accurate	Not Well Thought Out	Minimal Team Participation
Doesn't understand the Subject	Grade F	Not Applied properly	Less Than 60% Accurate	Minimal Effort	No effort to be part of the Team

Cadets will be expected to explain and apply concepts, not just memorize information; we will use essays, tests, quizzes, and oral presentations to have you demonstrate your understanding of different subject areas.

Grading Rubric - Quarterly

	A	B	C	D	F
Uniform Day participation 30%	90-100%	80-89%	70-79%	60-69%	Less than 60%
Tests and quizzes 35%	90-100%	80-89%	70-79%	60-69%	Less than 60%
Classroom participation 20%	90-100%	80-89%	70-79%	60-69%	Less than 60%
Daily work 20%	90-100%	80-89%	70-79%	60-69%	Less than 60%

We look forward to working with each of you throughout the year!

By signing below, we acknowledge that we have read and understand the Course Syllabus for Flanagan High School NJROTC and I am aware I must wear the Cadet Uniform on the required uniform day and I am required to “suit-up” for PT days in the appropriate PE clothing and tennis/athletic shoes. Wearing street clothes or non-athletic shoes during PE days does not count for credit.



→ _____
 Cadet Signature Date
 Print Name:

_____ Date
 Parent or Guardian Signature Date
 Print Name:

PARENT/GUARDIAN PERMISSION FORM (2023-2024)

I hereby request that my child, _____, be permitted to participate in the Flanagan High School Navy Junior Reserve Officer's Training Corps (NJROTC) Program. I understand that the Navy JROTC is a regular academic class offered by the Broward County Public School System. Further, I understand that my child will be required to participate in a physical fitness program, drill, and various activities and field trips away from the school campus.

I understand that the U.S. Navy requires that each cadet participating in the JROTC Program be covered by adequate medical insurance at the parent's expense in the event that the school does not provide such insurance. This medical insurance should cover any and all injuries that may occur either on or off of the school campus while participating in the JROTC Program.

I further attest that the following physical condition(s) of my child exist:

My child is physically qualified to participate in all aspects of the Navy JROTC Program.

My child is physically qualified to participate in the Navy JROTC Program with the following limitations (MUST HAVE PRE-PARTICIPATION PHYSICAL EVALUATION SIGNED BY A DOCTOR):

My child is not physically qualified to participate in the JROTC Program due to the following medical conditions, but request that my child be able to participate in the academic/leadership portion of the JROTC Program:

I certify that I am the parent/legal guardian of the above named child and that I have the legal right to execute this authorization.

→ _____
Printed Name

Signature

Relationship

Telephone Number

RELEASE AND HOLD HARMLESS AGREEMENT

This Release and Hold Harmless Agreement (“Released”) is made and entered into as of the date signed below, between the Charles W. Flanagan Navy JROTC Instructors and the undersigned student and parent/guardian.

Navy JROTC programs provide an opportunity for cadets to experience leadership training, confidence building, team building, strength and conditioning, and other developmental opportunities throughout the year including periods when school is not in session. The intent of the training is to develop young men and women to be physically fit, good citizens, who have confidence in themselves. This training comes in various forms, including standard physical fitness training, adventure training, practical application, and classroom instruction. Navy JROTC instructors will never intentionally put your cadet in danger or in a situation where injury could occur; however, “high risk” training, such as rappelling, high rope courses, zip lines, obstacle and confidence courses, swimming and rafting do come with some inherent risk. Ultimately, it is the parents (guardians) decision to allow a cadet to participate and by doing so, you will not hold the instructors liable should injury or death occur.

I AGREE TO ASSUME AND DO ASSUME FOR ALL PURPOSES ANY AND ALL RISKS OF INJURY WITHOUT RESERVATIONS, THEREBY RELEASING AND FOREVER DISCHARGING THE INSTRUCTORS, THEIR TRUSTEES, DIRECTORS, OFFICERS, EMPLOYEES AND AGENTS, AND I AGREE TO INDEMNIFY AND HOLD HARMLESS EACH AND ALL OF THE INSTRUCTORS PARTIES FROM AND AGAINST ANY AND ALL CLAIMS, ACTIONS, SUITS, PROCEDURES, COSTS, EXPENSES, DAMAGES AND LIABILITIES INCLUDING, BUT NOT LIMITED TO, ATTORNEYS’ FEES ARISING OUT OF, CONNECTED WITH, OR OTHERWISE RESULTING FROM ANY INJURY, DEATH, HARM OR LOSS I, MY CADET OR ANY MINOR PERSON WITH ME, OR WHOM I HAVE PROVIDED PERMISSION MAY SUFFER WHILE PARTICIPATING IN LEADERSHIP TRAINING ACTIVITIES IN CONJUNCTION WITH THE NAVY JROTC PROGRAM. I UNDERSTAND AND AGREE THAT THE RELEASE, INDEMNITY AND HOLD HARMLESS CONTAINED HEREIN SHALL APPLY AND BE ENFORCEABLE REGARDLESS OF ANY CONCURRENT NEGLIGENCE, OR THE SOLE NEGLIGENCE OR OTHER FAULT OF ANY ONE OR MORE OF THE INSTRUCTORS PARTIES.

I specifically agree that this Release is reasonable, the preceding provisions of this paragraph are conspicuous, this Release is fully enforceable, and that my execution hereof is completely voluntary. I furthermore understand that I, or my minor cadet, must behave in a responsible manner, that I am responsible for any minor with me, or whom I have released while participating in Navy JROTC leadership training, I agree that I, and my cadet, will obey and follow any rules implemented by the instructors and made available to us. Should I fail to understand any of such rules, I will ask an instructor for an explanation.

I CERTIFY THAT I HAVE READ THIS RELEASE AND FULLY UNDERSTAND AND AGREE TO ITS CONTENTS. AS USED HEREIN, I UNDERSTAND THAT THE TERM “I” INCLUDES ANY MINOR PERSON WITH ME OR WHOM I HAVE GIVEN PERMISSION TO PARTICIPATE.

By signing this form, the undersigned agrees that this Release is binding on the undersigned and their heirs, executors, administrators and assigns of the undersigned.

Parent Signature _____ Date _____

Printed Name _____

Cadet Signature _____ Date _____

Printed Name _____



CONSENT FOR TREATMENT

Minor's Name: _____ Date of Birth: _____

I hereby authorize physicians, nurses, athletic trainers, or any other healthcare provider (collectively "providers") of Broward Health ("BH") to conduct routine medical, medical screening, diagnostic, or any other procedure deemed necessary in order for the above minor child ("child") to participate in school athletics. In the event that an injury occurs to child while participating in school athletics, I further authorize and give permission to providers to render to my child appropriate and necessary care at that time. This may include but not be limited to the rendering of first-aid or emergency treatment. If medical necessity exists beyond that which can be reasonably dealt with on school grounds I further authorize and give permission to providers to arrange for professional medical transport to a medical facility. I understand that every effort will be made to contact the parent or guardian in the case of a medical emergency.

I understand that BH is a teaching facility and that medical, nursing, and other health care personnel in training may participate in child's care and that these individuals are not necessarily employees or agents of BH. I also understand that BH contracts with physicians and physician groups to provide services to patients, and that they may be independent contractors and are not necessarily the agents or employees of BH. I understand that BH is not legally responsible for the acts and omissions of its independent contractors or these individuals that are not employees or agents of BH. I acknowledge that no guarantees have been made to me regarding the results of any examination, care or treatment to be provided by any BH agent.

→ _____
Signature of Parent(s)/Guardian Date Signed Relationship to Minor

Name of Parent(s)/Guardian

Pre-existing medical condition:

Medication:

*Broward Health is affiliated with the University of Florida and Nova Southeastern Colleges of Medicine
And is an equal opportunity employer and affirmative action procurer of goods and services*

•Broward General Medical Center • North Broward Medical Center • Imperial Point Medical Center • Coral Springs Medical Center

Media Release Form 2023/2024 School Year (All Grades)

As a parent of a student in Broward County Public Schools, I understand that my child may be photographed, videotaped and/or interviewed by news media, schools and the District for informational and/or promotional purposes, as indicated below

You Must Mark a Choice in Both Section A and Section B

(If no choice is marked in both sections, then the choice will default to Choice #1)

Section A - External Outlets/Media

Please Check Choice #1 or Choice #2

-
1. ____ I **WILL** permit my student to be photographed, videotaped, and/or interviewed by the news media when the news media has secured proper authorization from Broward County Public Schools.
 2. ____ I **WILL NOT** permit my student to be photographed, videotaped, and/or interviewed by the news media.

Section B - Broward County Public Schools

Please Check Choice #1 or Choice #2

-
1. ____ I **WILL** permit permit my student to be photographed, videotaped, and/or interviewed for school publications (e.g., yearbooks and school newspapers), school and District communication tools (e.g., websites and social media), BECON-TV, and school events and activities. **Note: To facilitate school publications, the District may disclose information to approved vendors, such as student's name, student's home address, student/parent phone number, grade level, teacher names and classroom numbers. For sporting events, athletic team member positions and jersey numbers may be disclosed.**
 2. ____ I **WILL NOT** permit my student to be photographed, videotaped, and/or interviewed for school publications (e.g., yearbooks and school newspapers), school and District communication tools (e.g., websites and social media), BECON-TV, and school events and activities.

→ _____
Student Name (PRINT)

Student Signature

Date

Parent/Guardian Name (PRINT)

Parent/Guardian Signature

Date

NJROTC UNIFORM ISSUE AND TURN-IN PROCEDURES

Dear parents,

The following are guidelines for the initial uniform issue, and return policy:

1. Upon uniform issue, each cadet will be issued a custody card to be signed by the cadet and returned to the Naval Science classroom upon uniform issue.
2. All items must be turned in at the same time in order to facilitate complete and accurate accountability.
3. Upon turning in uniforms, your cadet will be issued a “Custody Card Receipt” indicating a cleared NJROTC account.
4. It is imperative that your cadet turns in their uniforms directly to the Naval Science Instructors in order for you to receive your Custody Card Receipt which will be your proof of a cleared NJROTC account. Turning in your uniforms to the school office WILL NOT guarantee that your account will be properly cleared.
5. If your cadet’s uniforms have not been turned in, or the account is not properly cleared, his/her name will appear on the school’s “**OBLIGATIONS**” list the day after disenrollment. ***If your cadet is a senior and has an obligation, he/she will not receive their graduation diploma***

I have read, understand and will comply with all of the above requirements and thoroughly understand that any infractions will result in appropriate disciplinary action.

→ _____ Cadet’s Name (Print)	_____ Cadet Signature	_____ Date
_____ Parent’s Name (Print)	_____ Parent Signature	_____ Date

Uniform Measurements and Hair Standards

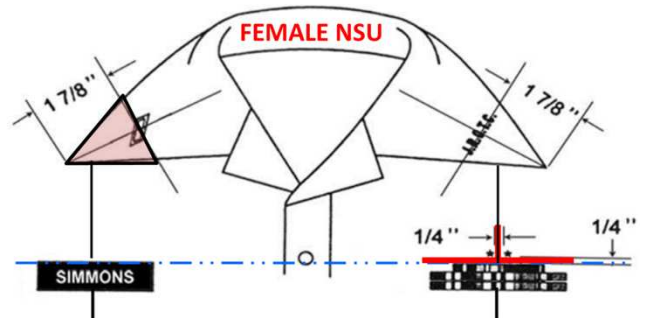
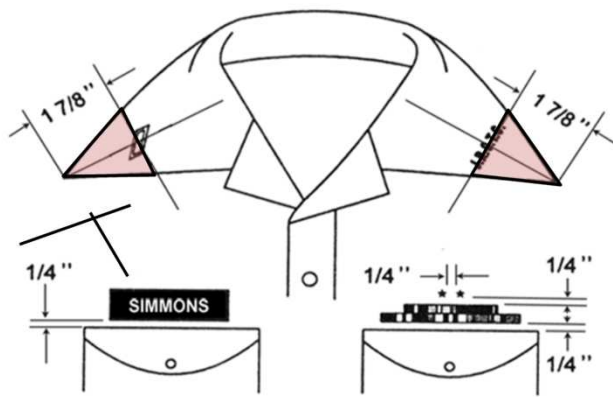
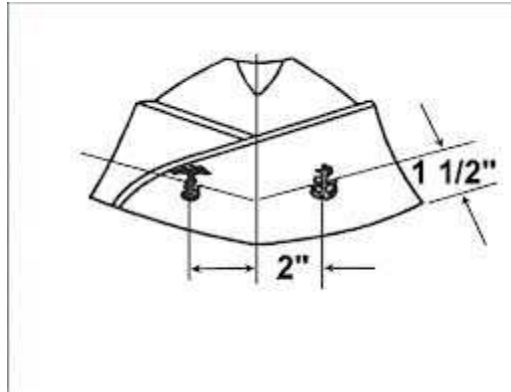

- Nametag Top aligned w/ Top Button - Centered on Seam
- Up to 3 Rows of Ribbons aligned w/ Top Button Centered on Seam - *Additional Ribbons work upward*
- Year Stars 1/4 Inch Above Ribbons

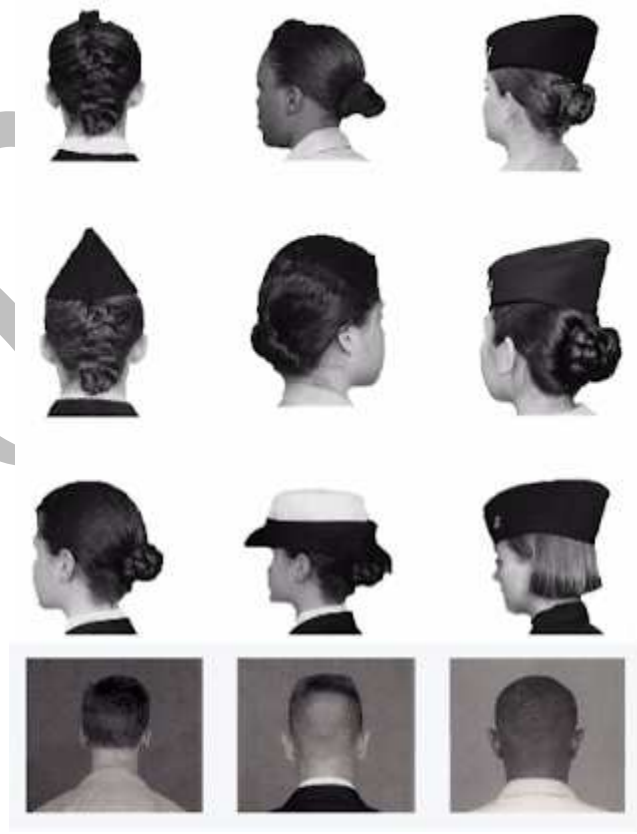



Cadet Personal Data Entry Form
(confidential when filled in)

Student Information

Last Name: _____ First Name: _____ MI: _____

Student ID: _____ Birth Date: (month/day/year) _____ Gender: Male _____ Female _____

Race: (Black/White/Asian/Other) _____ Ethnicity: (Hispanic-Latino/Non-Hispanic/Other) _____

Home Address:

Street: _____ Apartment: _____

City: _____ State: _____ Zip Code: _____

Home Phone: _____ Cell Phone: _____

Email: _____

School Year: _____ Date Enrolled: _____ Expected Graduation Date: _____

Class Period: _____

Parent/Guardian Information

Name: _____ Relationship: _____

Street: _____ Apt. #: _____ City: _____ State: _____

Zip Code: _____ Home Phone: _____ Cell Phone: _____ Work Phone: _____

Email: _____

Name: _____ Relationship: _____

Street: _____ Apt. #: _____ City: _____ State: _____

Zip Code: _____ Home Phone: _____ Cell Phone: _____ Work Phone: _____

Email: _____