

# L1/L2 Active GPS

# MPHS

Multi-  
Purpose  
Hatch  
System

R4 Integration, Inc. (R4) has designed and built the next generation C-130 Multi-Purpose Hatch System (MPHS) for installing customized airborne antenna and sensor configurations. The **0009A3000-10-430 MPHS** includes a rugged satcom antenna designed for airborne applications and is compatible with virtually any GPS receiver system. By simply replacing the existing forward escape hatch, the MPHS provides a “Roll On/Roll Off” rapid installation **without modification** to the aircraft. It requires no tools or special equipment to install and is proven to meet any short notice and critical communication needs.

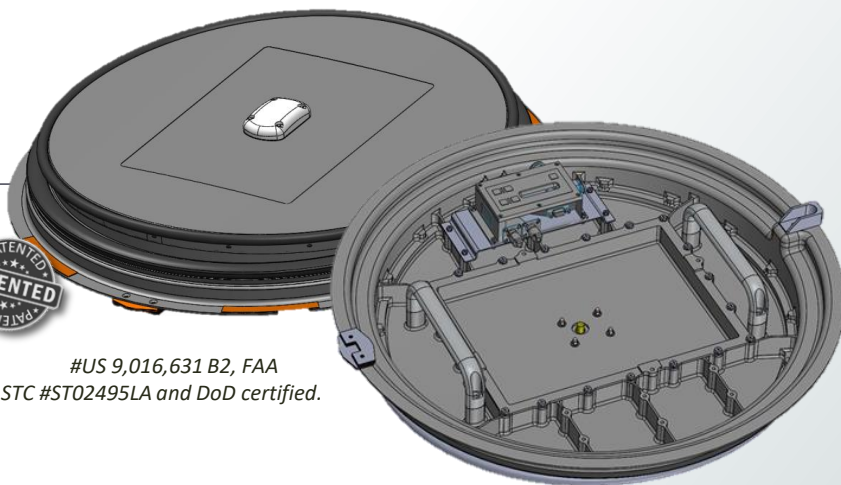

#US 9,016,631 B2, FAA  
STC #ST02495LA and DoD certified.



850.226.6913

[info@r4-integration.com](mailto:info@r4-integration.com)

**PART NUMBER:  
0009A3000-10-430**

## ANTENNA FEATURES

- BILLET ALUMINUM CONSTRUCTION
- NO MODIFICATION TO AIRCRAFT
- FIELD REPLACEABLE SEALS AND HARDWARE
- FAA/DoD CERTIFIED
- L1 AND L2 Active GPS

## SPECIFICATIONS

FREQUENCY	L1: 1575.42 ± 12 MHz L2: 1227.60 ± 12 MHz
GAIN (TYP)	GPS: +33dB LNA
RF POWER	GPS: 1W
HEIGHT ABOVE AIRCRAFT	0.75"
WEIGHT	18 lbs.