

Lucky Find

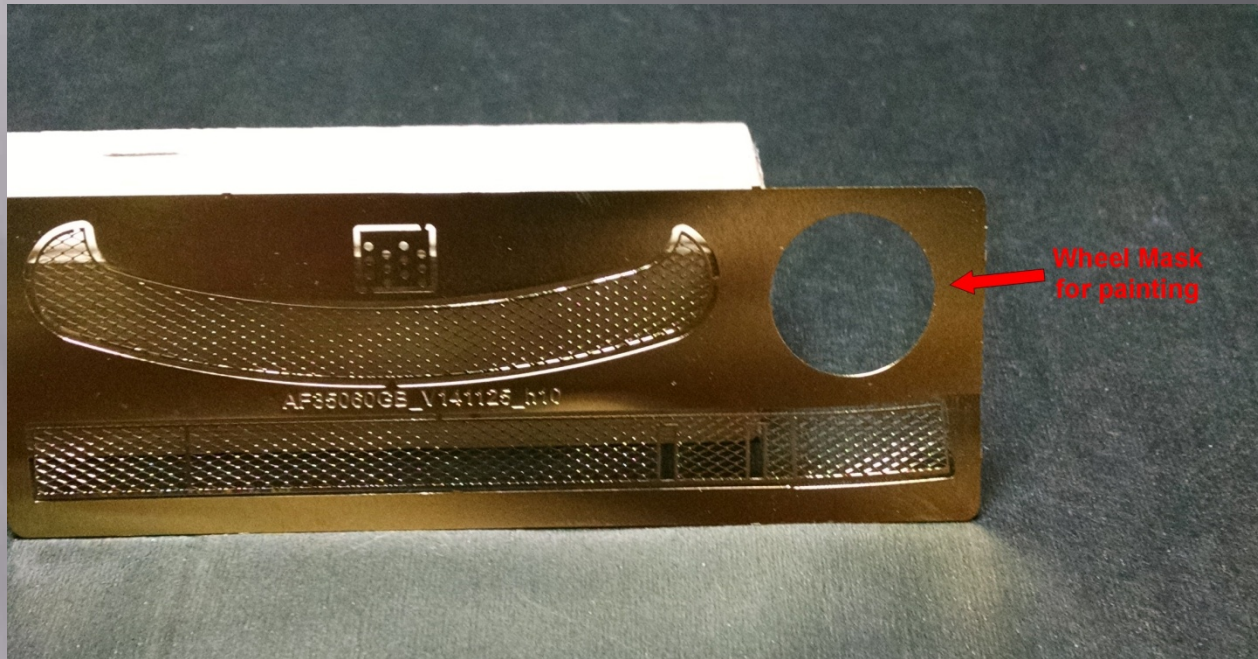

Purely by accident, I found that AFV has provided a wheel mask for painting the road wheels.

Options for the Driver's Compartment Assembly

- Leave the Driver's compartment empty if you are displaying the model with the Driver's hatch closed or you will have a Driver figure in the hatch.

- Assemble the Driver's compartment with only the kit components. *

- Assemble the compartment and add additional details which have been left out of the kit. **

* There is a good amount of detail with just the kit supplied parts. Even with no driver and the hatch open, there is enough to emulate an M60A1 Drivers area.

** There are several components missing in the compartment. I will show and describe how to add these features and correct inaccuracies in the compartment

Step 7

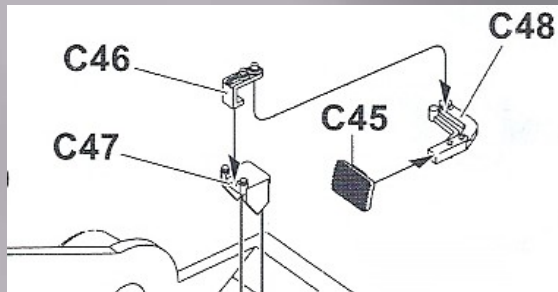

These 4 kit parts C 45/46/47/48 are very finicky to put together. Assemble C 46 and C 48 first, then attach C 47 and C45 respectively.

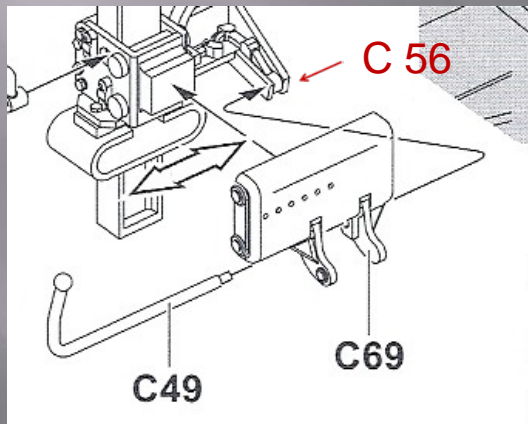
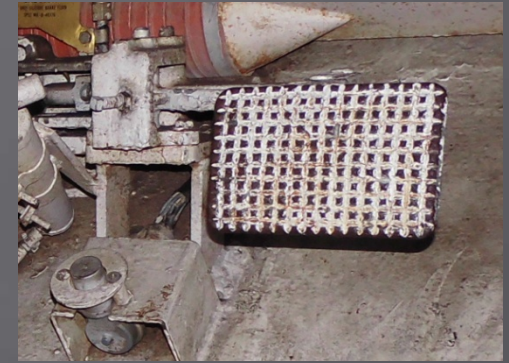

The instructions are not clear here, but note that part C 49 goes completely under part C 69 and attaches to part C 56.



Step 7

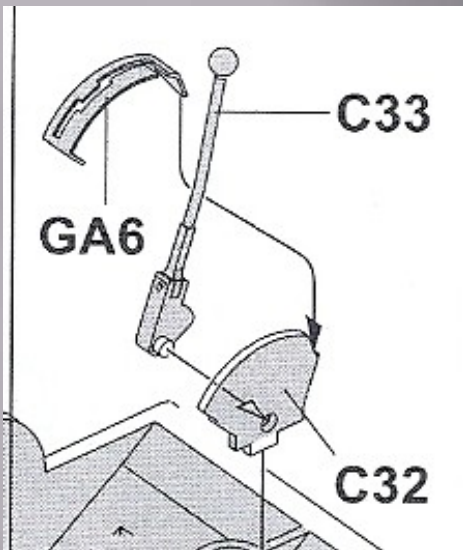

Part GA 6 is etched Brass. Be sure to form it (but **DO NOT CEMENT**) to part C 32 before attaching C 33 to C 32. Also be very careful when removing part C 33 from the sprue, as it is very fragile.

Assemble in the following steps:
Form GA 6 to C 32; attach C 33 to C 32; Attach GA 6.



All other assemblies and attachments in Step 7 are as noted in the instruction sheet.

Step 7

Finished lower hull Driver's area.

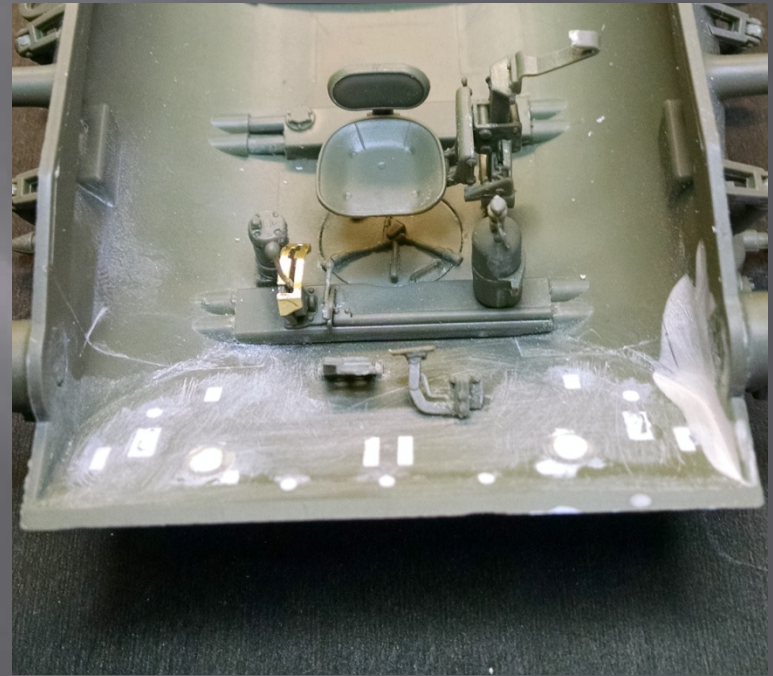
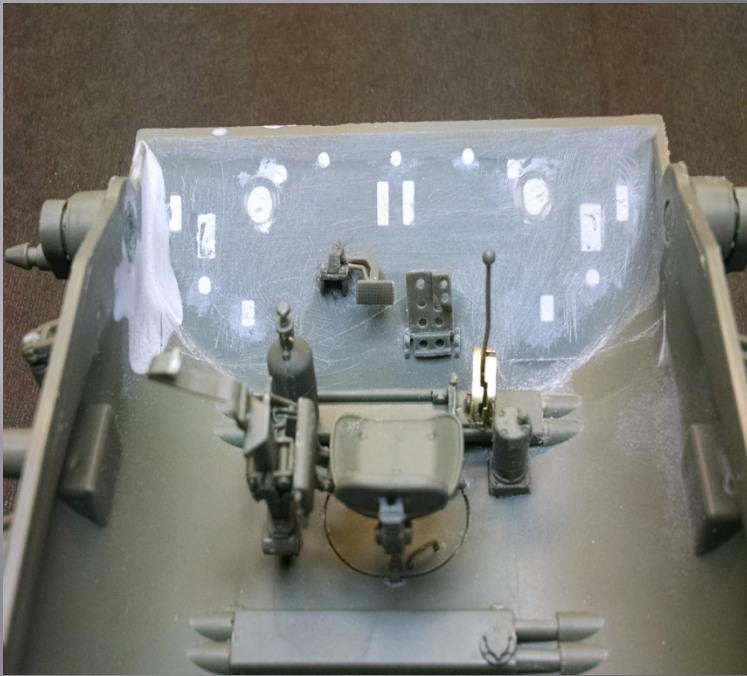

Step 8

The Driver's hatch in the kit is for the early M60A1. If you want to build the RISE (Passive), you will need to scratch build the periscope opening. *It can only be modeled shut as you won't have the IR periscope



My modified Driver's Hatch

It's hard to see the detail, but it's basically two thin pieces of sheet stock shaped in the form of the new periscope cover.



Step 8

Be sure to drill out the five holes as indicated in the instruction sheet for this step. Failure to do this will result in not being able to attach parts to the exterior in later steps.

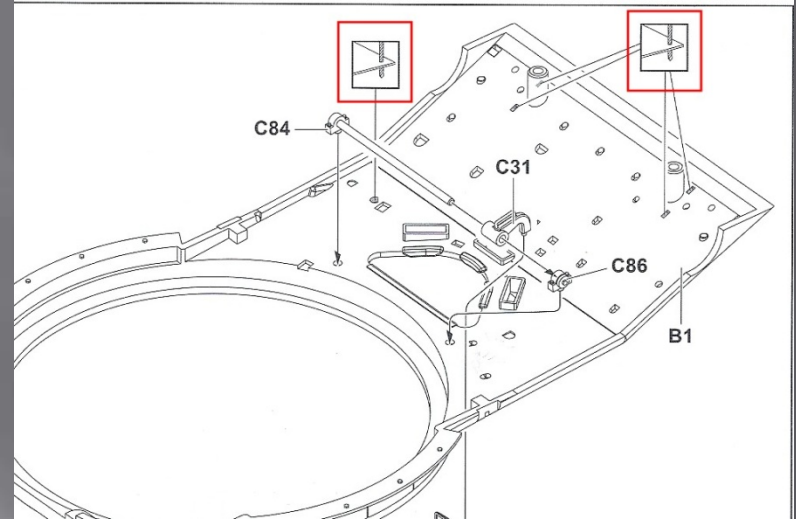

****** You may also want to wait to attach the Driver's hatch to the exterior if you are planning to leave it open. Future handling of the upper hull can lead to breaking the hatch off.

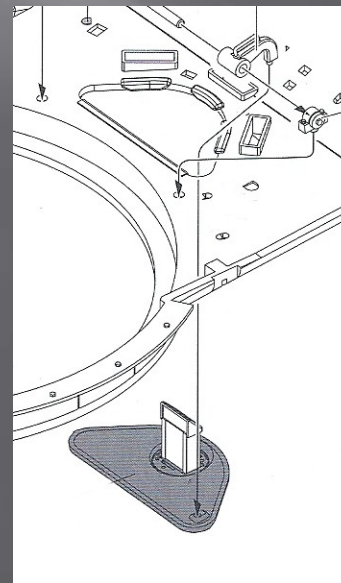

Step 9

Part E 2, on the kit, is mounted to the roof of the Driver's area at an angle to the Driver's position. On a real vehicle, it was more parallel to the Driver's position.

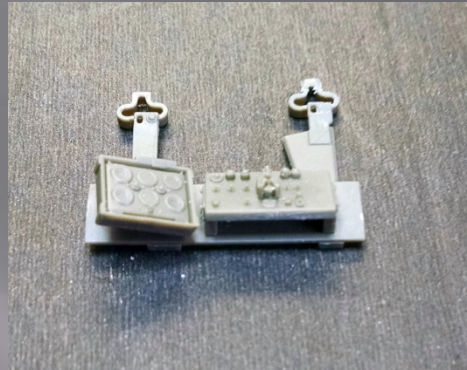

** This is not a problem unless you plan to add more detail in the Driver's area.

Parts C 38/39 area mislabeled on the instruction sheet. They should be **B 38/39**.

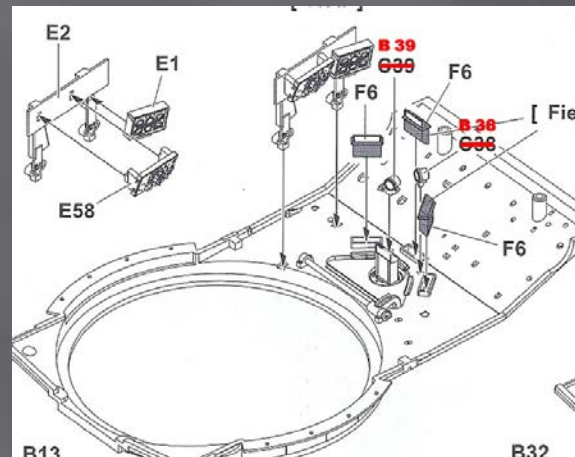

Step 9

The fire suppression pull handles and cover parts B 8, B 13 and E 72 need to be assembled differently than depicted on the instruction sheet. It will be much easier if you attach B 8 E 72, then add parts B 13.

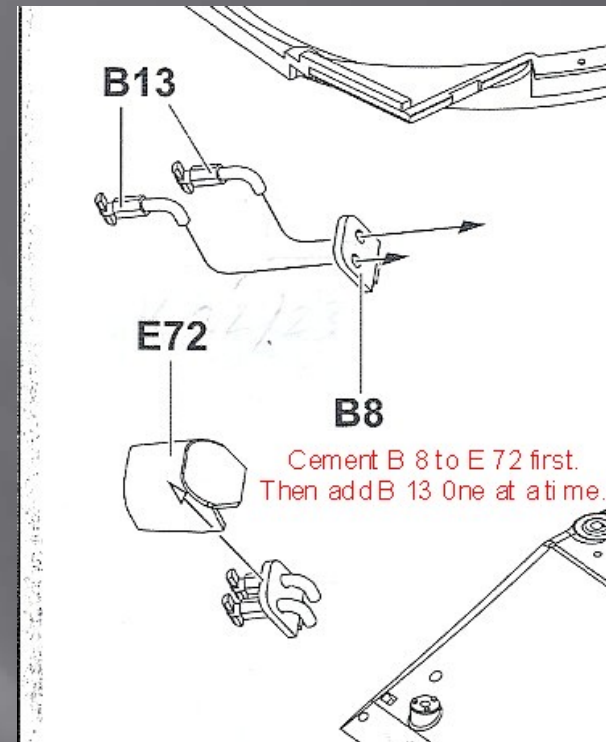

***Part E 51 (the Driver's "T-Bar") is **very fragile**, and should be removed from the sprue with great care to avoid breaking it.

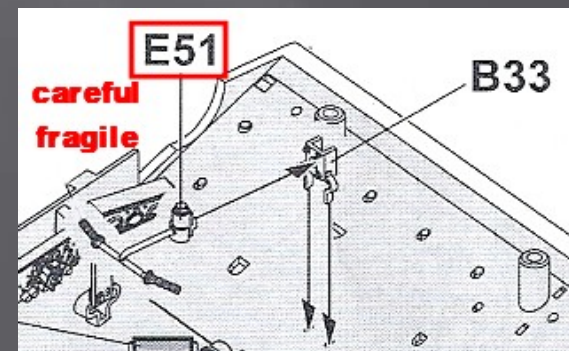

Added detail in the Driver's area.

The first thing I did was remove the locator studs (not really used in assembly of the model) and then fill in all indentations. After sanding everything smooth, I began building and adding detail.

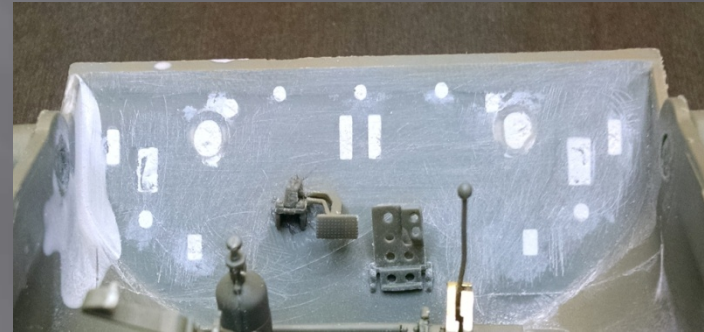

I began by making a jig for the assembly of the “Ready Rack” tubes that are on both sides of the Driver's area.

This was assembled from scrap plastic.

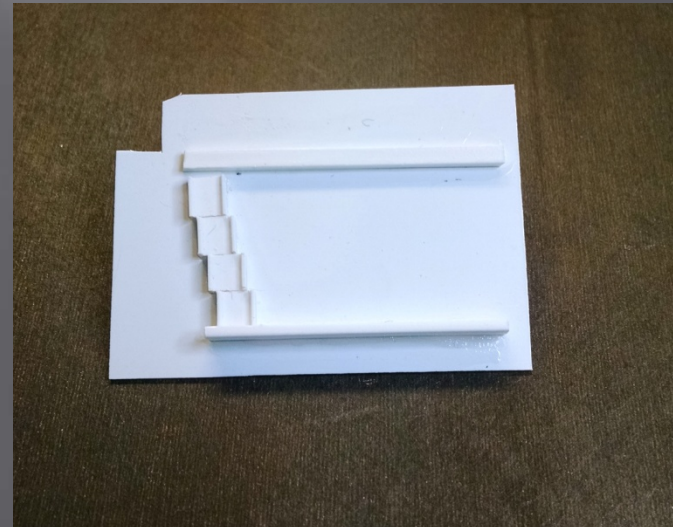

Added detail in the Driver's area.

Next I cut the tubes from 3/16 plastic tubing. You will need 8 (minimum number) of these 1" long. There are actually several rows of these on both sides of the Driver's position, but I opted to only do the first row on each side.

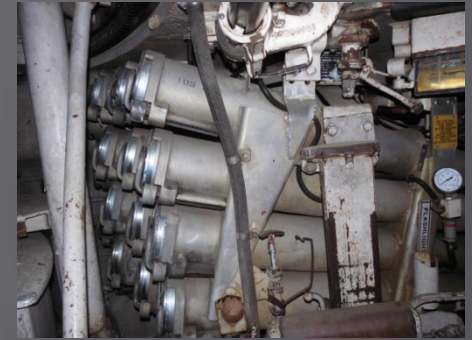
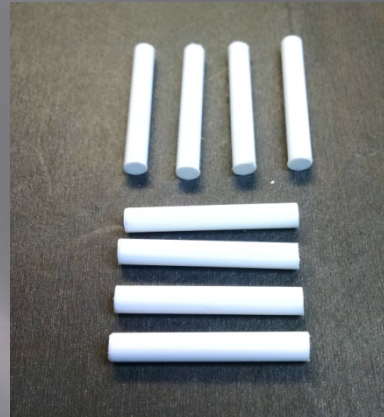

Picture of actual tubes

I used a punch set to make ends for the tubes

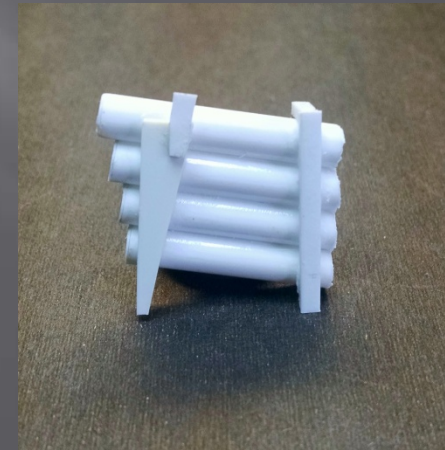
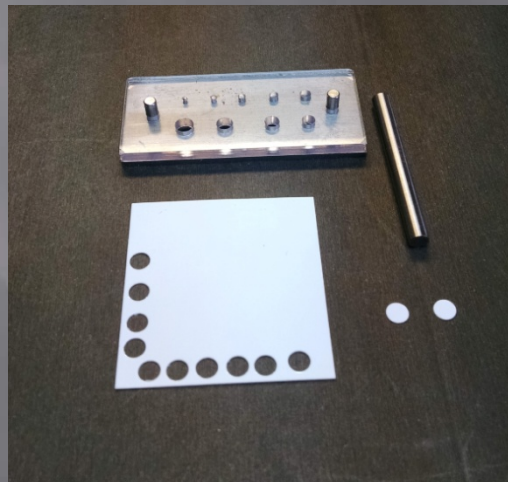

Picture of assembled tubes for the left side.

Added detail in the Driver's area.

Next is the crew heater. This is made similar to the tubes, just shorter. It measures 5/8" long.

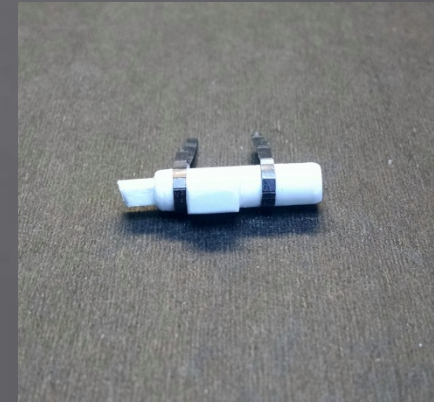
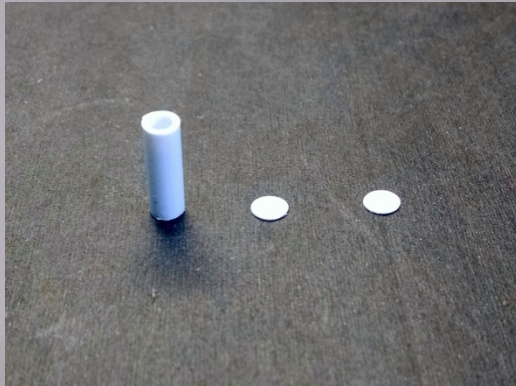

Heater is located behind spare light and "Ready Rack" tubes



Added detail in the Driver's area.

Next, the control panels on the right side need some additional details.

I scratched the upper panel and the two control boxes to the left above the square panel with the 6 gauges.

Once those were done, I attached them above the kit provided panels.

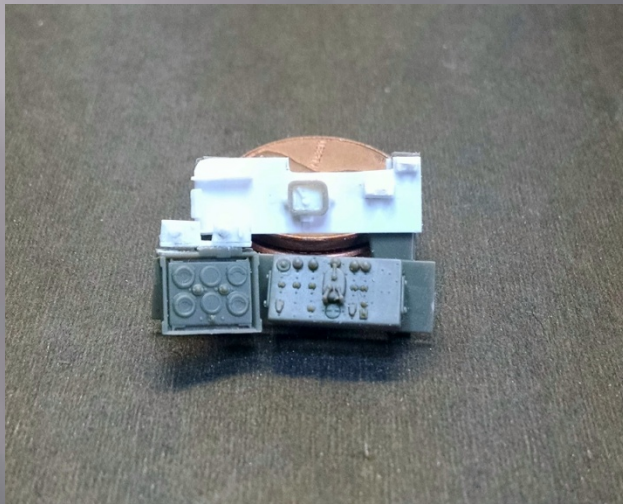
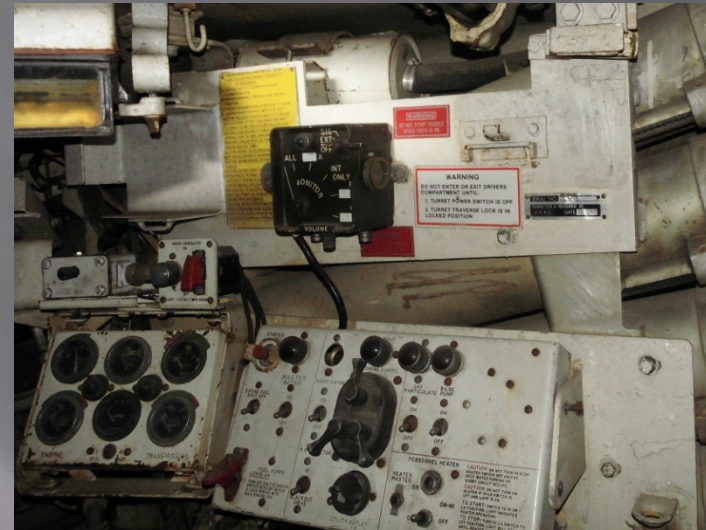

Finished panels

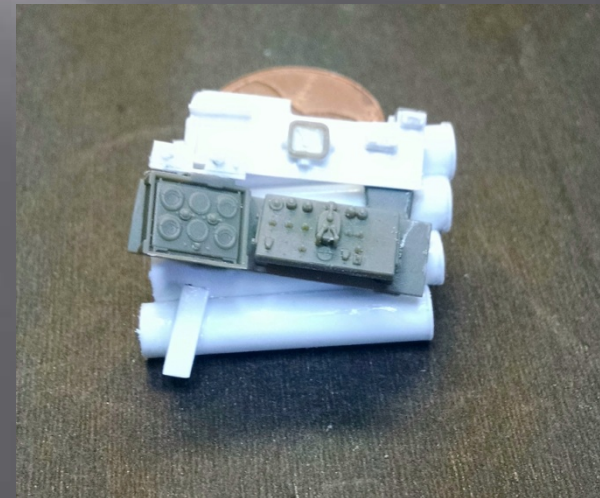

Attached to the right side "Ready Rack" tubes

Added detail in the Driver's area.

There are two additional fixed Fire Extinguishers on the left side behind the "Ready Rack" tubes.



I got mine from an old Tamiya M60A1 kit, but they can be easily fabricated from plastic tubing or rod.

Added detail in the Driver's area.

Once all of the sub assemblies and parts were finished, I added everything to the Drivers area with some wiring and conduit to tie things together.

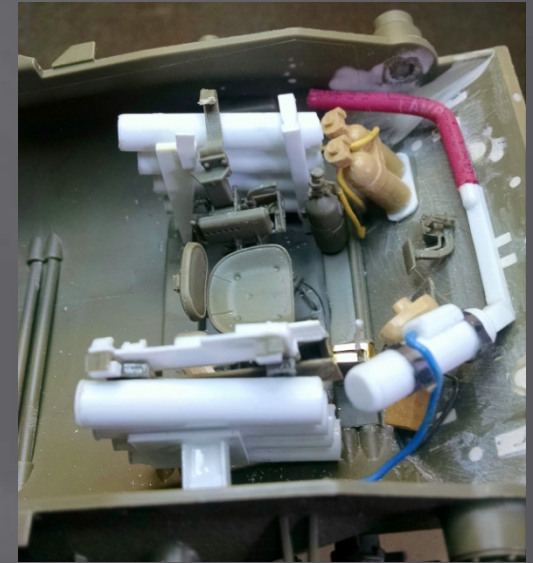
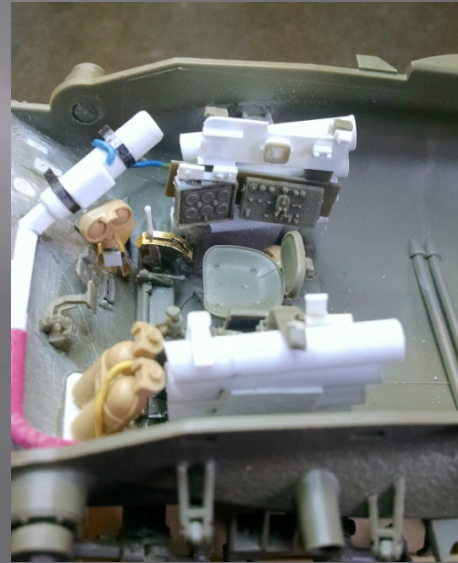
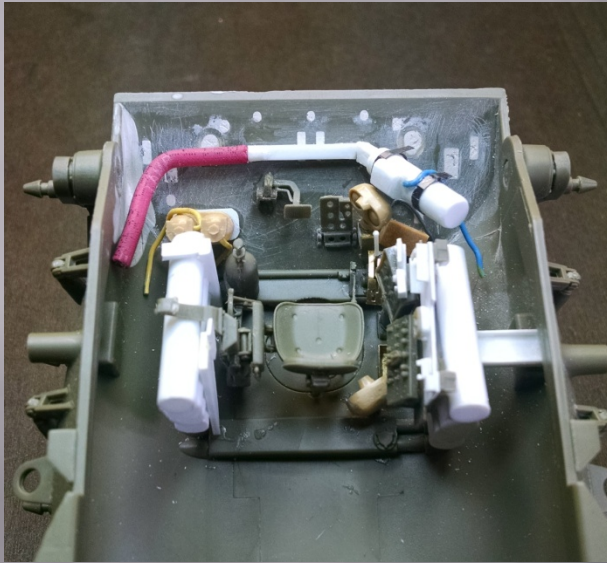

*** Note: There are mountings in the Driver's area for two headlights. They could hold spares or the dismantled vehicle headlights.



Reference pictures of the Driver's area for those who want to add detail.



Reference pictures of the Driver's area for those who want to add detail.



Added detail in the Driver's area.

The only additional detail I added to the upper hull portion were wiring for the two gauges and the steering linkage for the Driver's "T-Bar."

The Driver's three periscopes can be mounted opened, closed or a combination . The right and left periscopes were fixed. By this I mean they were either in the mounts in an up position or removed. The center periscope was actually adjustable. It could be lowered in it's mount to allow for Driver visibility when "opened up" or for the Driver to use his hatch mounted periscope.

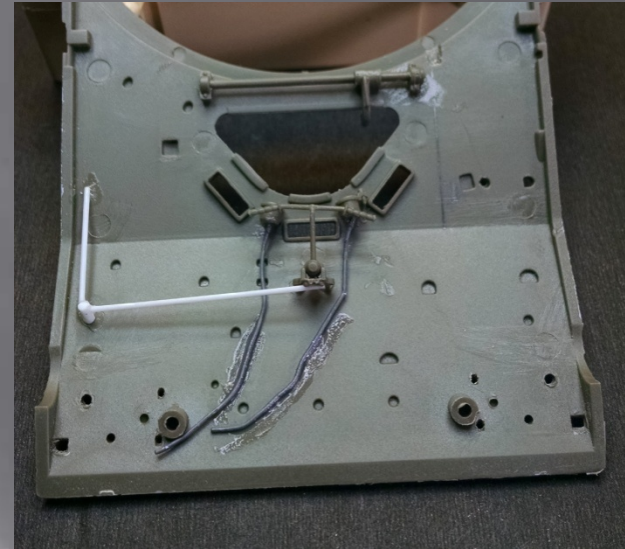

AMPS Atlanta 2017 Club Project

Next Month – Steps 10 - 20 the Hull Exterior

