

MVC503R-MB



Compact actuator with electronic emergency return for PICVs and globe valves

MODEL	CONTROL	POWER SUPPLY	FORCE [N]	IP
MVC503R-MB	Modbus	24 Vac/dc	300	54



APPLICATION AND USE

MVC503R-MB actuator with fail safe function can be used with valves push/pull (using auto stroke calibration mode) or with valves with spring using fixed stroke mode. The main application is to control hot/cool water flow rate in two/four pipes terminal units, zone, small reheating and dehumidification coils. Fail safe function is used in all the applications where we need to specify the valve position (fully open or fully closed) in case of power failure.

The Modbus control is perfect for systems with large numbers of control valves where the number of I/O points of the BMS can be drastically reduced using a field bus.

MVC503R-MB is equipped with MODBUS (SLAVE) communication protocol enabling the communication with other MODBUS devices (MASTER).

OPERATION

MVC503R-MB is an electrical bidirectional actuator. The valve stem is activated through a stepper motor and a gear train optimised in order to have high performances and minimal noise emissions.

The actuator is equipped with super capacitors able to provide the energy to fully close or fully open the valve in case of power loss. The final position of the actuator can be selected via Modbus configuration.

The actuator is equipped with a mechanism able to stop the motor when the force of 300 N is reached. If auto stroke calibration is set, the software enables the stroke calibration, so it can be used on any valve, as long as it respects the maximum stroke limit allowed (12 mm max).

MVC503R-MB is a modulating actuator and it can be controlled through Modbus connection directly from the BMS without the need of a voltage or current control signal. The actuator is also equipped with 5 LEDs whose operation is explained in the table at page 5.

VALVE & ACTUATOR COMPATIBILITY

MVC503R-MB is used with ISMA CONTROLLI valves without spring. The actuator has a joint that allows a solid connection to the valve stem.

MVC503R-MB can also be used with ISMA CONTROLLI valves with spring. In this case the actuator is not solidly connected to the valve stem, but pushes the stem downwards during movement; the return of the stem is done by the spring on the valve itself which guarantees the contact of the stem with the actuator.

In case of use of non ISMA CONTROLLI valves please contact technical secretariat for proper adaptor.

The table shows the compatible valve models:

The performances stated in this sheet can be modified without any prior notice.

MODEL	VALVES WITHOUT SPRING				
	VSB.T-VMB.T 3/4" .. 2" STROKE 5,5 mm	2-3TGB15B 1/2" STROKE 11,5 mm	2-3TBB.T 1/2" .. 2" STROKE 12 mm	2TGA.BT 3/4" .. 2" STROKE 8,5 mm	VALVES OF OTHER MANUFACTURERS STROKE max 12 mm
MVC503R-MB	●	● AG74-03	●	●	●

MODEL	VALVES WITH SPRING			
	VLX / VLX.P 3/4" .. 1 1/4" STROKE 4 mm	VSXT/VMXT/VTXT 1/2" .. 3/4" STROKE 5,5 mm	VSXT.PBP 1 1/2" STROKE 5,5 mm	VSB.T.-VMB.T. 3/4" .. 1 1/2" STROKE 5,5 mm
MVC503R-MB	●	●	●	●

It is possible to set the stroke value using the parameter "Actuator Stroke". For furthermore details see the paragraph MODBUS PARAMETERS.

WARNING - In case of MVC used on a valve produced before September 2019 to replace an MVT, the 55061 kit must be used.

VALVE (production previous September 2019)	ACTUATOR to be replaced	Replacement KIT
VSB.T-VMB.T	MVT203	55061
2-3TBB.T	MVT403	
2-3TGB.B	MVT503	

MANUFACTURING CHARACTERISTICS

The actuator housing is made of a polymeric fireproof material; a metal ring nut M30x1,5 is dedicated to the connection with the valve.

The actuator is equipped with a 5 wires cable for electric connection.

SAFETY REQUIREMENTS

1. Install on the power supply line a protecting device to avoid short circuits (fuse or magneto-thermic) according to the specifications;
2. in case of accidental removal of the cover and/or of the connector cover, make sure that power is disconnected before working on the actuator or near it;
3. the products are maintenance free.

VARIANTS

PS107 actuator with M28x1,5 ring nut.

ACCESSORIES

AG74-03 2-3TGB.B iSMA CONTROLLI valves adaptor (N.B. to be used in replacing of the spindle extension provided with the valves).
55061 Kit of adapters for coupling the actuator with VSB.T-VMB.T, 2-3TBB.T and 2-3TGB.B series valves produced before September 2019.

In case of use of non iSMA CONTROLLI valves please contact technical secretariat for proper adaptor.

TECHNICAL CHARACTERISTICS

CHARACTERISTIC	DESCRIPTION
Power supply	24 Vac/dc ± 10%
Speed (selectable via Modbus)	5 s/mm (default) or 3 s/mm
Force	300 N (UNI 9497:1989)

CHARACTERISTIC		DESCRIPTION
Cable		5 wires 1,5 m (CEI 20-22/II)
Weight		0,4 kg
Protection degree		IP54
Feedback signal		via Modbus
Charging time for supercapacitors		~ 45 sec
Speed in Emergency positioning		3 s/mm
Transformer sizing		30 VA
Consumption	supercapacitor charging	12 W
	moving	6 W
	holding position	1,5 W
Manual override		with 3 mm hex key
Max stroke		12 mm
Operation temp		-5T55 °C
Storage temp		-25T65 °C
Reference Directives and Standards		EMC 2014/30/UE according to EN 61326-1: 2013

INSTALLATION AND MOUNTING

When assembled with valve with spring, before assembling the valve and the actuator, check that the actuator screw jack is fully retracted. If not, remember that, to mount the actuator on the valve in the right position, you have to overcome the spring force of the valve itself. Screw in the M30x1,5 ring nut firmly on the valve thread.

For all the valves without spring, mount the actuator on the valve screwing in the M30x1,5 ring nut without locking it; using the manual override make the screw jack go down until to align the actuator spindle slot with the locknut (A), secure with the bolt (B) through threaded hole in locknut (A). Rotate the actuator in the desired position and lock the M30x1,5 ring nut. Respect the orientation of the actuator shown in the figures below.

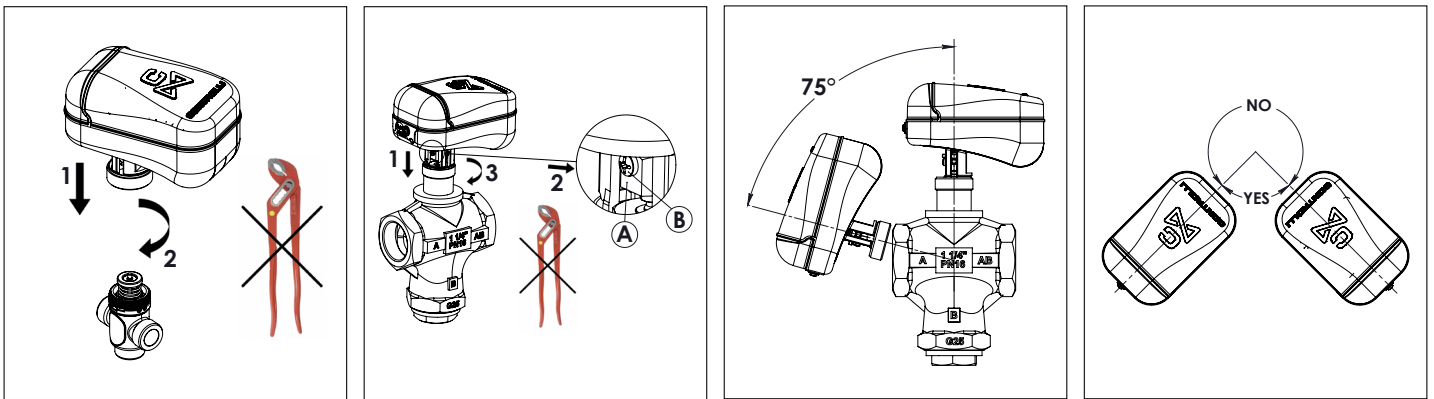

WIRING DIAGRAM

Wiring shall be executed according to the local valid laws.

To check the direction of movement of the spindle, compare the direction of rotation of the manual override with the indication on the base. The movement of the valve stem can also be observed through the slots in correspondence with the fixing ring nut.

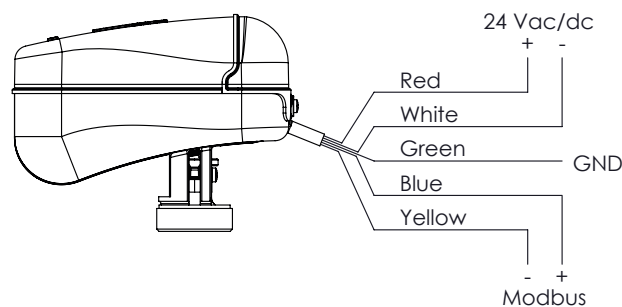

SETTINGS AND FUNCTIONS

Actuator settings has to be done via Modbus. The Modbus Database where all the available registers are described is provided at pag. 5. Factory settings are detailed in the table it self.

The default factory setting of the Modbus address is 1, to modify it follow these instructions:

1. Remove the cover and the connector (look at the following picture)
2. Change the DIP switches as indicated in the DIP SWITCHES table.
3. The new settings will be active on the next power off/on cycle.

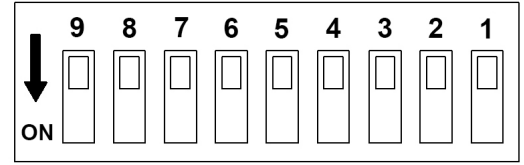
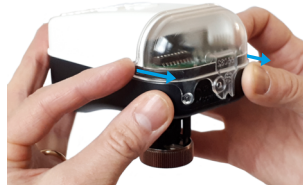

Modbus - RS485 Connection

The RS485 network is implemented with a 3-conductor cable, which will be later identified as "+", "-" and "GND".

For wiring is suggested Belden®, model 8762.

For "disturbed" areas is suggested a Belden®, model 3106A using the twisted pair to connect the "+" and "-", the reference wire to connect to "GND" and the shield to connect to ground.

Alternatively you can use a cable with the following electrical and mechanical characteristics:

- AWG 20/22;
- characteristic impedance of 120Ω;
- copper wire, "plait" type, twisted;
- shielded braided and insulated.

The shield must be connected to controller GND.

The network must be wired only in accordance with the principle shown here, called "daisy chain" (the device is composed by a single RS485 port). Star connections are not allowed.

Connections warnings

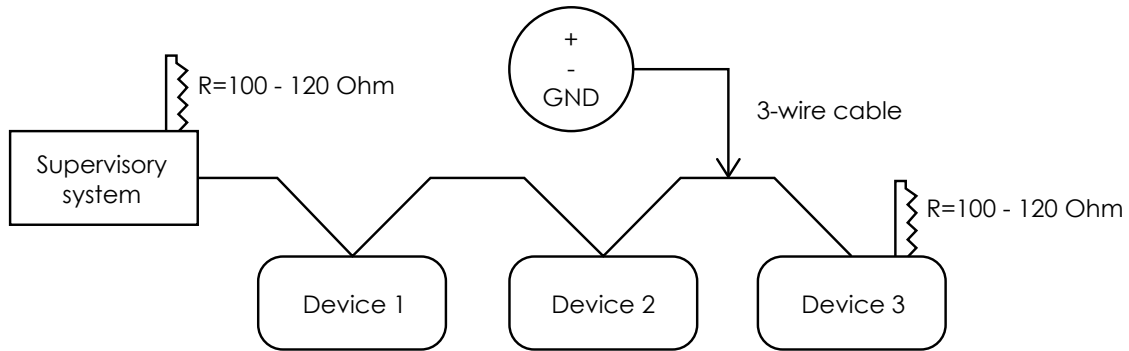

For proper network cabling is recommended to take the following precautions:

1. Do not use different types of cable to achieve the same network, but always use only the same type of cable;
2. The network cable carries out safety voltage signals (SELV) and must not be wired together with dangerous voltage signals (e.g., 230Vac) or carriers of high currents, especially if in alternating current. Also avoid parallel paths to these power cables;
3. Wire the cable lying avoiding kinks, narrow bending radii and unnecessary wrapping in hanks or skeins;
4. Do not twist the cable cord around the power conductors and, if they should cross, consider an intersection at 90 ° between the cable and these conductors;
5. Keep away from sources of electromagnetic field in particular by large motors, electrical cabinet, reactors for neon, all types of antennas;
6. Do not pull the power cable exceeds 110N (11.3kg) to prevent ironing;
7. Assess in advance the route so that it will be as short as possible and note addresses of connected instruments with particular reference to its location in the orderly sequence. This can be very useful in maintenance; we recommend to note the Modbus Address on the product label.
8. Do not reverse the polarity "+" and "-" of the connection terminals;
9. Avoid short lengths of cable terminations in connection tools to make a maintenance without tearing or flues of the cables possible;
10. Identify start and ending terminations and avoid cuts "open".

Recharge supercapacitors

When the actuator is powered on the supercapacitors charging phase start automatically.

1. during the charging phase DL1 (red), DL2 (green), DL3 (yellow) and DL5 (red) are ON (solid);
2. charging phase will be completed after about 40 s when DL1 (red), DL2 (green), DL3 (yellow) and DL6 (green) are ON;
3. the actuator is ready for operation when DL1 (red), DL2 (green), DL3 (yellow) switch OFF and DL6 (green) is ON.

During the supercapacitors recharge phase, Modbus communication is not possible.

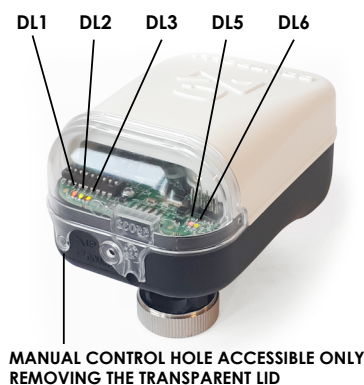

Control Position

The position of the actuator can be defined by the BMS through a dedicated Modbus parameter ranging between 0% and 100% where 0% means actuator fully retracted (direct action) and 100% means actuator fully extended (direct action). If reverse action is enabled 0% means actuator fully extended and 100% means actuator fully retracted.

Calibration

This function allows to detect the maximum valve stroke, so that the actuator can drive the valve correctly following the control signal. If the actuator is powered on, this action can be repeated any time DIP 9 goes from OFF to ON or by setting a specific Modbus parameter (for valves with auto stroke calibration). Maximum valid stroke 12 mm.

Auto stroke calibration / Fixed stroke

Through Modbus the user can choose (on the basis of the coupled valve) if the stroke must be fixed or automatically calibrated. Valve stroke can be set via Modbus at any values ranging from 2,5 mm and 12 mm.

The actuator can be coupled with valves without spring using auto stroke calibration or to valves with spring return using fixed stroke mode.

Direct/Reverse action

The actuator is supplied without default stroke. Automatic calibration is performed at first power up (Plug and play function).

Direct/reverse action can be set via Modbus. In direct action the actuator is fully retracted when control position is 0% and valve position feedback is 0%. With reverse action the actuator is fully extended when control position is 0% and valve position feedback is 0%.

Initial Positioning

It is executed every time the actuator is powered and after the calibration phase. This operation allows the actuator to start from a known position and then follow the command signal. This position depends on the selection of direct or reverse action.

Unexpected stall condition

If an unexpected stop during the stroke occurs, this function has the aim to make it disappear. The actuator will be driven in the opposite direction and then it will try again to reach the position.

If it was not unlocked after the first 3 attempts, after a 1 minute pause, 3 more attempts are made.

Valve Position Feedback

The feedback of the current valve position is made available by a specific Modbus parameters ranging from 0 to 1000 (dividing this value by 10 gives the feedback value as a percentage). During the "automatic stroke calibration" and "Initial positioning" function it is set at 1200 (corresponding to 120%). During the emergency positioning function the feedback parameter is set to 11100 (corresponding to 110%).

Manual override

To activate the manual override, remove the power supply, remove the transparent cover and insert a 3 mm hexagonal key into the front hole and turn the key until the desired position is reached.

Plug & Play

Automatic calibration is performed at the very first power up.

Actuator Speed setting

The speed of the actuator can be set via Modbus from 5 s/mm (default value) to 3 s/mm.

Linear/Equipcentage

Actuator position characteristic is normally linear, but MVC503R-MB allow to set an equipcentage behaviour allowing to make a linear valve working like an equipcentage valve.

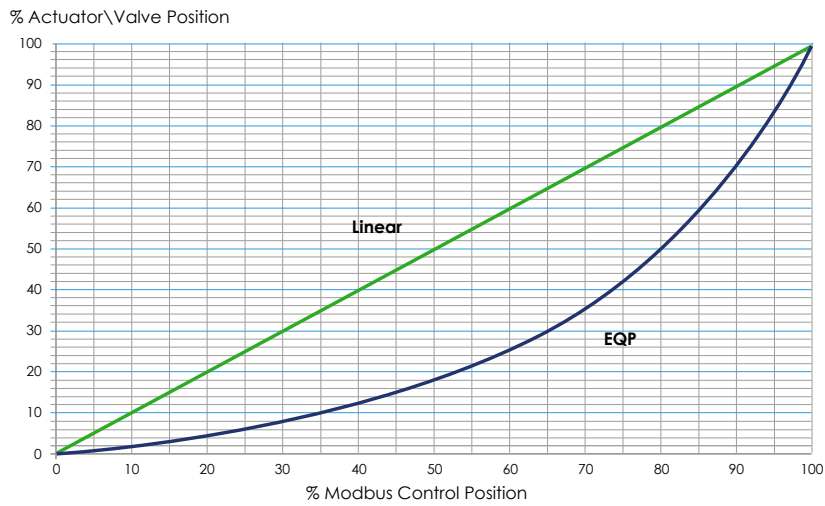

Diagnostic Functions

MVC503R-MB offer a number of diagnostic functions made available through Modbus:

- "Actuator Status" (similar to LED behaviour);
- "No. of Openings" showing how many times the actuator has been fully retracted;
- "No. of Closing" showing how many times the actuator has been fully extended;
- "First Power up" showing if the actuator has been powered for the first time or not;
- "Low voltage anomaly" showing how many times the power supply voltage has been lower than the specified range (also includes low voltage due to emergency return);
- "High voltage anomaly" showing how many times the power supply voltage has been higher than the specified range;
- "Unexpected stalls" showing how many times the actuator detected unexpected stalls during operations;
- "Extra-stroke" showing how many times the actuators detected a stroke higher than the last calibrated stroke;
- "Calibration Error" showing how many times the calibrated stroke failed because the actuator stroke is outside the range.

Restore factory settings

To restore the device to factory settings:

1. Switch DIP8 to ON;
2. Disconnect the actuator until the supercapacitors are completely discharged (all the LEDs are OFF);
3. Power up the actuator;
4. Wait for the supercapacitors to fully charge (see paragraph "Recharge supercapacitors");
5. Auto stroke calibration restarts automatically;
6. Switch DIP8 to OFF.

LED BEHAVIOUR

Description	DL1 (red)	DL2 (green)	DL3 (yellow)
Calibration	Alternate blinking 5 Hz		ON
Initial positioning	Alternate blinking 1 Hz		ON
Running UP	OFF	Blinking 1 Hz	ON
End of stroke UP	OFF	ON	ON
Running DOWN	Blinking 1 Hz	OFF	ON
End of stroke DOWN	ON	OFF	ON
Holding	OFF	OFF	ON
Unexpected stall	Blinking 5 Hz		ON
Low voltage power supply	OFF	OFF	Blinking 1 Hz
High voltage power supply	OFF	OFF	Blinking 5 Hz
Calibrated stroke lower than minimum	Blinking 1 Hz	ON	ON
Calibrated stroke higher than max	ON	Blinking 1 Hz	ON
Extra stroke	Blinking 5 Hz	OFF	ON
Actuator OFF	OFF	OFF	OFF
Emergency positioning	Blinking 1 Hz		OFF
Supercapacitor charging phase	ON	ON	ON

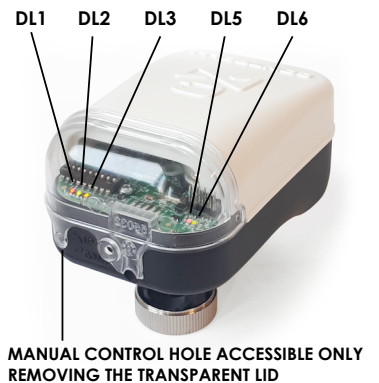

Description	DL5 (red)	DL6 (green)
Emergency return phase / Supercapacitor charging phase	ON	OFF
Supercapacitor charging phase completed	OFF	ON

DIMENSIONS [mm]

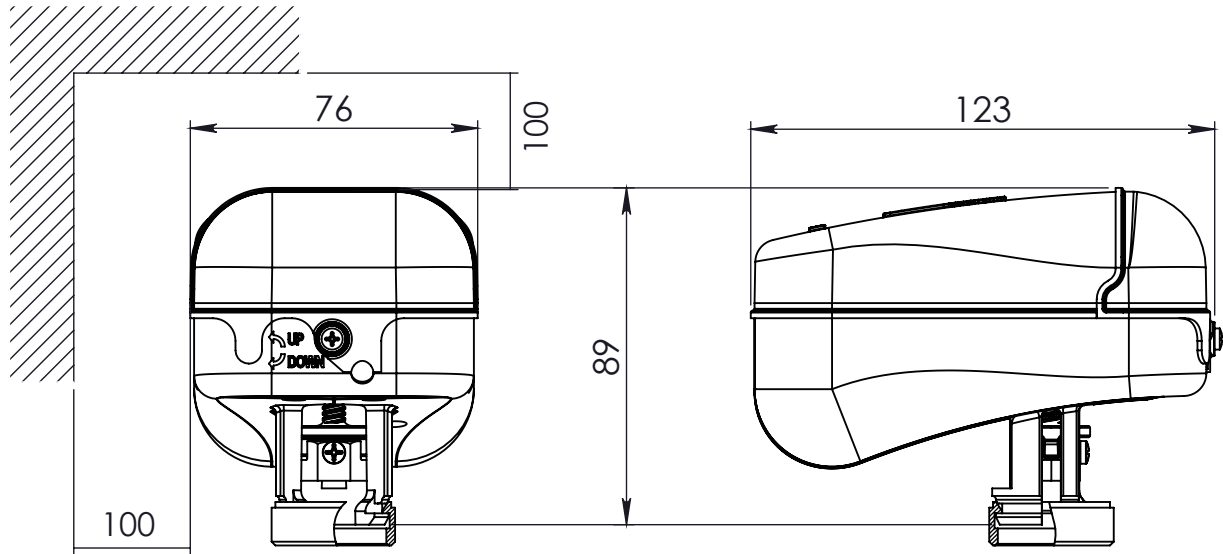

Ad- dress	Modbus Register	Description	Range	Default	RD/WR	Persi- stence
6678 6679 6680	Firmware version	"Firmware version (composed of 3 bytes): 1st byte: major version 2nd byte: minor version 3rd byte: revision version"	0-FFFFFF	0xFFFFFFFF	RD	YES
6681	First power up	Represents the first power up event	0xCF value	0xFF	RD	YES
6682	Calibration error	Represents the number of times a stroke error has occurred down the minimum allowed	0-FE	0xFF	RD	YES
6683	Calibration error	Represents the number of times a stroke error has occurred up the maximum allowed	0-FE	0xFF	RD	YES
6684	Low voltage anomaly	Represents the number of times a low voltage event has occurred	0-FE	0xFF	RD	YES
6685	High voltage anomaly	Represents the number of times a high voltage event has occurred	0-FE	0xFF	RD	YES
6686	Unexpected stalls within the race	Represents the number of times a stall has occurred within the run	0-FE	0xFF	RD	YES
6687	Extra stroke in normal operation	Represents the number of times that an extra stroke error has occurred compared to that calculated during the calibration phase (stroke out of range)	0-FE	0xFF	RD	YES
6688	Actuator stroke	"Identifies the value read by the actuator after the calibration phase. It is possible to set the stroke value but requires restarting the actuator. The value must be stored multiplied by 10."	20-120 (2 mm-12 mm)	FF (there is no need to initialize the value)	RD/WR	YES
6689	Actuator setting	Direct/reverse action setting	0-15	Direct action (bit0=1)	RD/WR	YES
		Forcing calibration phase		Calibration not enabled (bit1=1)		
		Emergency return direction selection (up or down)		Down (bit2=1)		
		Fixed stroke		Fixed stroke not enabled (bit3=1)		
6690	Actuator speed	Allows you to set the speed of the actuator	207 (5 s/mm) or 119 (3 s/mm)	"207 (5 s/mm)"	RD/WR	YES
6691	LIBRA valve type configuration	By selecting the type of PICV LIBRA valve, the stroke value is automatically set to 4 mm and reverse action	0-1	0 (NO PICV)	RD/WR	YES
6692	Characteristic configuration of the valve (β)	It represents the characteristic of the valve ($\beta=0$ linear valve, $\beta=1$ equal percentage valve)	0-1	0	RD/WR	YES
6693	Baud rate	Represents the communication speed of the Modbus protocol (9600, 19200)	0-2	0x00	RD/WR	YES
6694	Parity bit and stop bit	2 least significant bits (bits 0 and 1): parity bit (0 = none, 1 = even, 2 = odd) bit 4: stop bit (0 = 1 stop bit, 1 = 2 stop bit)	0-16	16	RD/WR	YES
6146	Opening phase	It is the number of times the actuator has been in the total opening position	0-65279	0xFFFF	RD	YES
6147	Closing phase	It is the number of times the actuator has been in the total closing position	0-65279	0xFFFF	RD	YES
8840	Actuator control	Represents the percentage of control of the actuator (by setting a value between 0 and 100% it allows to drive the motor in any position)	0-100%	0	RD/WR	NO
8841	Actuator operating status	Represents the current operating status of the actuator (based on the status of the LEDs)	0-16	0xFF	RD	NO
8842	Reset actuator	Allows you to perform a software reset of the actuator	0-1	0	RD/WR	NO
8288	Valve position (feedback)	Represents the position of the actuator	0-1000 (divide by 10 to have a % value) (calibration 1200, emergency return 1100)	FF (there is no need to initialize the value)	RD	NO
8289	Valve flow rate	In the case of selection of the PICV, it represents the percentage flow rate value (the value of the feedback register is not available)	0-1000 (dividere per 10 per aver valore %)	FF (there is no need to initialize the value)	RD	NO

DIP SWITCHES

DIP7	DIP6	DIP5	DIP4	DIP3	DIP2	DIP1	MODBUS ADDRESS
OFF	OFF	OFF	OFF	OFF	OFF	OFF	Factory setting (default 1)
OFF	OFF	OFF	OFF	OFF	OFF	ON	1
OFF	OFF	OFF	OFF	OFF	ON	OFF	2
OFF	OFF	OFF	OFF	OFF	ON	ON	3
OFF	OFF	OFF	OFF	ON	OFF	OFF	4
OFF	OFF	OFF	OFF	ON	OFF	ON	5
OFF	OFF	OFF	OFF	ON	ON	OFF	6
OFF	OFF	OFF	OFF	ON	ON	ON	7
OFF	OFF	OFF	ON	OFF	OFF	OFF	8
OFF	OFF	OFF	ON	OFF	OFF	ON	9
OFF	OFF	OFF	ON	OFF	ON	OFF	10
OFF	OFF	OFF	ON	OFF	ON	ON	11
OFF	OFF	OFF	ON	ON	OFF	OFF	12
OFF	OFF	OFF	ON	ON	OFF	ON	13
OFF	OFF	OFF	ON	ON	ON	OFF	14
OFF	OFF	OFF	ON	ON	ON	ON	15
OFF	OFF	ON	OFF	OFF	OFF	OFF	16
OFF	OFF	ON	OFF	OFF	OFF	ON	17
OFF	OFF	ON	OFF	OFF	ON	OFF	18
OFF	OFF	ON	OFF	OFF	ON	ON	19
OFF	OFF	ON	OFF	ON	OFF	OFF	20
OFF	OFF	ON	OFF	ON	OFF	ON	21
OFF	OFF	ON	OFF	ON	ON	OFF	22
OFF	OFF	ON	OFF	ON	ON	ON	23
OFF	OFF	ON	ON	OFF	OFF	OFF	24
OFF	OFF	ON	ON	OFF	OFF	ON	25
OFF	OFF	ON	ON	OFF	ON	OFF	26
OFF	OFF	ON	ON	OFF	ON	ON	27
OFF	OFF	ON	ON	ON	OFF	OFF	28
OFF	OFF	ON	ON	ON	OFF	ON	29
OFF	OFF	ON	ON	ON	ON	OFF	30
OFF	OFF	ON	ON	ON	ON	ON	31
OFF	ON	OFF	OFF	OFF	OFF	OFF	32
OFF	ON	OFF	OFF	OFF	OFF	ON	33
OFF	ON	OFF	OFF	OFF	ON	OFF	34
OFF	ON	OFF	OFF	OFF	ON	ON	35
OFF	ON	OFF	OFF	ON	OFF	OFF	36
OFF	ON	OFF	OFF	ON	OFF	ON	37
OFF	ON	OFF	OFF	ON	ON	OFF	38
OFF	ON	OFF	OFF	ON	ON	ON	39
OFF	ON	OFF	ON	OFF	OFF	OFF	40
OFF	ON	OFF	ON	OFF	OFF	ON	41
OFF	ON	OFF	ON	OFF	ON	OFF	42
OFF	ON	OFF	ON	OFF	ON	ON	43
OFF	ON	OFF	ON	ON	OFF	OFF	44
OFF	ON	OFF	ON	ON	OFF	ON	45

DIP7	DIP6	DIP5	DIP4	DIP3	DIP2	DIP1	MODBUS ADDRESS
OFF	ON	OFF	ON	ON	ON	OFF	46
OFF	ON	OFF	ON	ON	ON	ON	47
OFF	ON	ON	OFF	OFF	OFF	OFF	48
OFF	ON	ON	OFF	OFF	OFF	ON	49
OFF	ON	ON	OFF	OFF	ON	OFF	50
OFF	ON	ON	OFF	OFF	ON	ON	51
OFF	ON	ON	OFF	ON	OFF	OFF	52
OFF	ON	ON	OFF	ON	OFF	ON	53
OFF	ON	ON	OFF	ON	ON	OFF	54
OFF	ON	ON	OFF	ON	ON	ON	55
OFF	ON	ON	ON	OFF	OFF	OFF	56
OFF	ON	ON	ON	OFF	OFF	ON	57
OFF	ON	ON	ON	OFF	ON	OFF	58
OFF	ON	ON	ON	OFF	ON	ON	59
OFF	ON	ON	ON	ON	OFF	OFF	60
OFF	ON	ON	ON	ON	OFF	ON	61
OFF	ON	ON	ON	ON	ON	OFF	62
OFF	ON	ON	ON	ON	ON	ON	63
ON	OFF	OFF	OFF	OFF	OFF	OFF	64
ON	OFF	OFF	OFF	OFF	OFF	ON	65
ON	OFF	OFF	OFF	OFF	ON	OFF	66
ON	OFF	OFF	OFF	OFF	ON	ON	67
ON	OFF	OFF	OFF	ON	OFF	OFF	68
ON	OFF	OFF	OFF	ON	OFF	ON	69
ON	OFF	OFF	OFF	ON	ON	OFF	70
ON	OFF	OFF	OFF	ON	ON	ON	71
ON	OFF	OFF	ON	OFF	OFF	OFF	72
ON	OFF	OFF	ON	OFF	OFF	ON	73
ON	OFF	OFF	ON	OFF	ON	OFF	74
ON	OFF	OFF	ON	OFF	ON	ON	75
ON	OFF	OFF	ON	ON	OFF	OFF	76
ON	OFF	OFF	ON	ON	OFF	ON	77
ON	OFF	OFF	ON	ON	ON	OFF	78
ON	OFF	OFF	ON	ON	ON	ON	79
ON	OFF	ON	OFF	OFF	OFF	OFF	80
ON	OFF	ON	OFF	OFF	OFF	ON	81
ON	OFF	ON	OFF	OFF	ON	OFF	82
ON	OFF	ON	OFF	OFF	ON	ON	83
ON	OFF	ON	OFF	ON	OFF	OFF	84
ON	OFF	ON	OFF	ON	OFF	ON	85
ON	OFF	ON	OFF	ON	ON	OFF	86
ON	OFF	ON	OFF	ON	ON	ON	87
ON	OFF	ON	ON	OFF	OFF	OFF	88
ON	OFF	ON	ON	OFF	OFF	ON	89
ON	OFF	ON	ON	OFF	ON	OFF	90
ON	OFF	ON	ON	OFF	ON	ON	91
ON	OFF	ON	ON	ON	OFF	OFF	92

DIP7	DIP6	DIP5	DIP4	DIP3	DIP2	DIP1	MODBUS ADDRESS
ON	OFF	ON	ON	ON	OFF	ON	93
ON	OFF	ON	ON	ON	ON	OFF	94
ON	OFF	ON	ON	ON	ON	ON	95
ON	ON	OFF	OFF	OFF	OFF	OFF	96
ON	ON	OFF	OFF	OFF	OFF	ON	97
ON	ON	OFF	OFF	OFF	ON	OFF	98
ON	ON	OFF	OFF	OFF	ON	ON	99
ON	ON	OFF	OFF	ON	OFF	OFF	100
ON	ON	OFF	OFF	ON	OFF	ON	101
ON	ON	OFF	OFF	ON	ON	OFF	102
ON	ON	OFF	OFF	ON	ON	ON	103
ON	ON	OFF	ON	OFF	OFF	OFF	104
ON	ON	OFF	ON	OFF	OFF	ON	105
ON	ON	OFF	ON	OFF	ON	OFF	106
ON	ON	OFF	ON	OFF	ON	ON	107
ON	ON	OFF	ON	ON	OFF	OFF	108
ON	ON	OFF	ON	ON	OFF	ON	109
ON	ON	OFF	ON	ON	ON	OFF	110
ON	ON	OFF	ON	ON	ON	ON	111
ON	ON	ON	OFF	OFF	OFF	OFF	112
ON	ON	ON	OFF	OFF	OFF	ON	113
ON	ON	ON	OFF	OFF	ON	OFF	114
ON	ON	ON	OFF	OFF	ON	ON	115
ON	ON	ON	OFF	ON	OFF	OFF	116
ON	ON	ON	OFF	ON	OFF	ON	117
ON	ON	ON	OFF	ON	ON	OFF	118
ON	ON	ON	OFF	ON	ON	ON	119
ON	ON	ON	ON	OFF	OFF	OFF	120
ON	ON	ON	ON	OFF	OFF	ON	121
ON	ON	ON	ON	OFF	ON	OFF	122
ON	ON	ON	ON	OFF	ON	ON	123
ON	ON	ON	ON	ON	OFF	OFF	124
ON	ON	ON	ON	ON	OFF	ON	125
ON	ON	ON	ON	ON	ON	OFF	126
ON	ON	ON	ON	ON	ON	ON	127

DIP8	FUNCTION
ON	Restore factory settings

DIP9	FUNCTION
ON	Auto stroke calibration

ATTENTION: When auto stroke calibration start move DIP9 to OFF.
 With auto stroke DIP9 carries out initial positioning and learning, with fixed stroke it only carries out initial positioning.