

OFFICE BUSINESS SOLUTIONS INC.

SUBJECT: SC542 OCCURS SYMPTOM:

SC542 still occurs after the SOLUTION SC555 is performed.

CAUSE:

Temperature is mis-detected by the thermistor(s).

When the paper used contains a lot of calcium carbonate and/or generates paper dust, these materials tend to mix with toner and then stick to the surface of the Hot Roller. As a result, the surface of the thermistor(s) also tends to become dirty, triggering a misdetection.

The following are other factors contributing to the above symptom:

- • Toner dusting due to monthly low volume,
- • TD sensor initialized more than once,
- • Engine Clear or Total NV RAM clear performed without replacing developer and 95% of the total copies are less than 5 – 7% toner coverage.

SOLUTION:

Perform the following:

1. Set SP1902-002 (Fusing Web Motor Control) to the following values.

- This will increase the amount of web that is fed out, improving the cleaning of the Hot Roller. MP6002: 14 (Default: 18)
MP7502: 12 (Default: 15)

2. Set SP1902-004 (Web Near End Value) to a value of 60 (Default: 80).

- This will adjust the timing of the Web Near-End alert by changing the amount of web that is fed out (SP1902-002).
- Changing SP1902-002 from the default value to 14 (MP6002) or 12 (MP7502) will decrease the PM cycle of the cleaning web from 450K to 350K.

APPLICABLE MODEL:

LANIER – MP 6002/MP 7502/MP 9002 RICOH – AFICIO MP 6002/MP 7502/MP 9002
SAVIN – MP 6002/MP 7502/MP 9002

SUBJECT: MULTIPLE SYMPTOM:

An ADF Jam (J003, J005, J006, J053 and J054) with no drive from the Transport Rollers occurs.

CAUSE FOR JAM (J006) AND OTHER ADF JAMS:

Binding in the Drive Belt area causes intermittent Transport Motor failure resulting in a Jam (J006).

SOLUTION FOR JAM (J006) AND OTHER ADF JAMS:

Clean and lightly lube the ADF Idler Pulleys and Shafts as shown below.

CAUSE FOR JAM J003, J005, J053 AND J054:

Jam code 003,005,053 and 054 occurs mainly in a high-volume scanning environment. This symptom may or may not occur during a copy job. ADF scan speed during scanning process is 188 images per minute using letter size in duplex. Before performing this bulletin, please check the following based on customers scanning volume.

Front view of ADF
Clean and lube the Idler
Pulleys and Shafts as shown here.

1. 1) SP 8191 – Provides total scans during copy / scan jobs.
2. 2) ADF pm is performed every 120k.
3. 3) Check if customer's originals are exposed to moisture / physical damage.
4. 4) Check if customer is scanning any NCR paper.

Perform the following Steps.

Step 1: Perform a thorough physical inspection and check the following parts for wear. Replace the worn parts.

- Item 21: D4122252 - Guide: Paper Feed: Lower
- Item 13: D4122111 - Roller: Pull Out: Drive
- Item 12: B6522411 - Roller: Scanning: Entrance: Drive
- Item 11: D4122121 - Roller: Middle: Drive

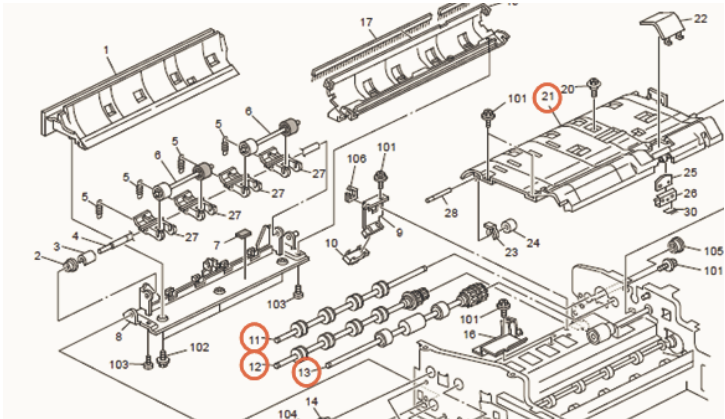

Item *: D4120331 - Transport Belt Unit: Assembly

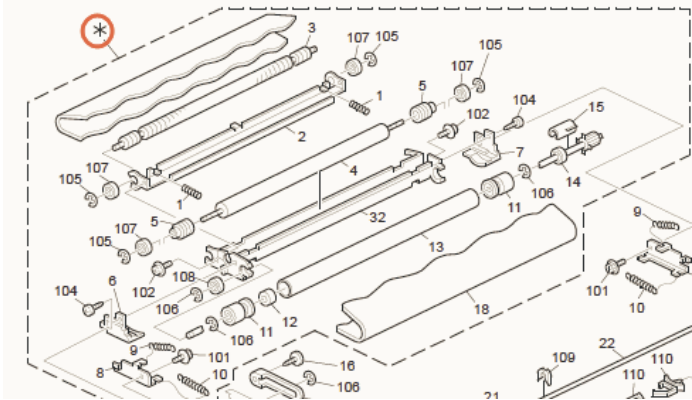

Item 21: D6092347 - Guide: Paper Feed: Upper

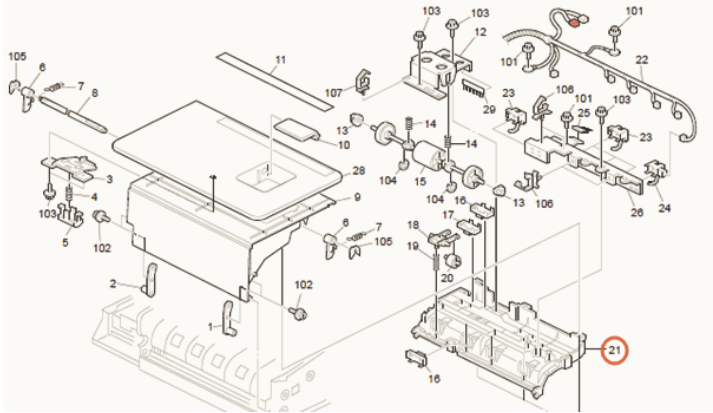

continued...

Step 2: Remove Item 21 (D4122252 -Guide Paper Feed Lower) shown below.

Step 3: Remove metal clip and white rubber pad as shown below.

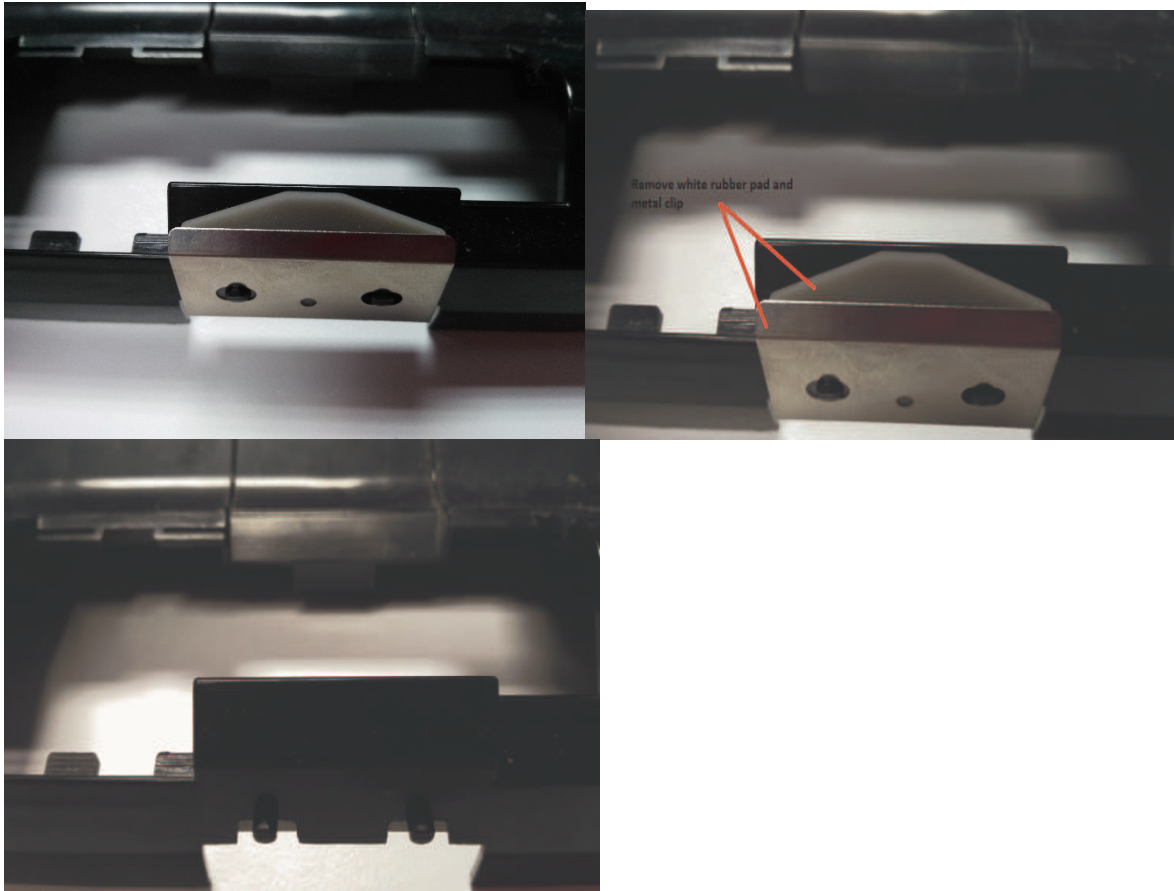

continued...

Step 4: Order mylar (part number D6832417) and attach it 1.5 mm above line shown below.

Step 5: Install the rubber pad and metal clip as shown below.

Step 6: Before installing item 21 (D4122252) check the locating pin which holds the torque limiter is secure as shown below.

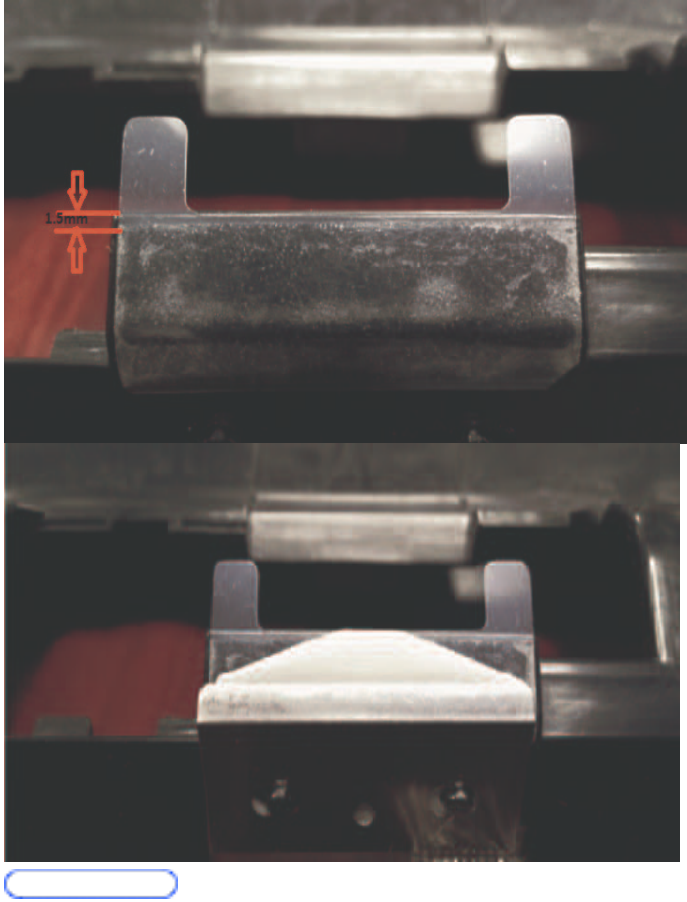

• The modification of adding Mylar (D6832417) is based on following conditions:

- 1) Majority of the customer jobs are scanning.
- 2) Customer run mixed sizes.
- 3) Originals are damaged / contain moisture.
- 4) Rubber pad (B301155) can be removed if the

original's lead edge gets damaged.

