

# SMART CITY SMART LIGHTING

Smart life, makes life better

**Lighting and Power**  
Technologies LLC

**Watran**  
light from the heart

THE  
INTERNET  
OF  
THINGS

P [Power Plug] [Security Camera] [Wi-Fi] [Speaker] [Lightbulb]

**Lighting and Power**  
Technologies LLC

[www.lightingandpowertech.com](http://www.lightingandpowertech.com)

**Lighting and Power Technologies**

7101 Whisperfield Drive, Plano, TX 75024 Ph: 877-666-5267 Fax: 972-624-5800  
[sales@lightingandpowertech.com](mailto:sales@lightingandpowertech.com) [www.lightingandpowertech.com](http://www.lightingandpowertech.com)



# CONTENTS

## 01 Smart City Solution

- a. Smart Street light
- b. 10Gps City Data Exchange Box  
Smartbox<sup>®</sup>
- c. BPL 200Mps Broadband Power Line Transmission

## 02 Smart Lighting

- a. Smart Street light Management system
- b. Bluetooth 5.0 automation system
- c. DALI Indoor Dimming System
- d. DMX512 Lighting Control Management System

# SMART CITY



Public Services



Smart Lighting



Public Broadcasting



Video Surveillance



WIFI



Charging Pile



Smart parking

## What is a smart city?

A smart city is an urban area that uses different types of electronic data collection sensors to supply information which is used to manage assets and resources efficiently. This includes data collected from citizens, devices, and assets that is processed and analyzed to monitor and manage traffic and transportation systems, power plants, water supply networks, waste management, law enforcement, information systems, schools, libraries, hospitals, and other community services. The smart city concept integrates information and communication technology (ICT), and various physical devices connected to the network (the Internet of things or IoT) to optimize the efficiency of city operations, services and connect to citizens. Smart city technology allows city officials to interact directly with both community, city infrastructure and to monitor what is happening in the city and how the city is evolving.

## The status & challenge of smart cities

A Smart City uses new technologies and data as a way of addressing the city's economic, social and environmental challenges. The challenges encountered today are the limitation of the network coverage that hindered the accessibility of IoT devices supporting efficiency and scalability of the add-on services. The demand for street lighting transformation has not only limited the simple replacement of LED street light, but also proposed a smart street lighting transformation. The most efficient to create a reliable and advanced digital network technology is to transform the streetlight into digital and electrical city platform that will address the above challenges economically.

## Smart City Solutions

In response to the development of intelligent streetlight, Watran and Timely Digital (TD) have jointly developed ready to use advanced solutions for high speed broadband access compatible with existing communication infrastructure. The Broadband power line (BPL) technology are connected and transmitted broadband signals over the existing power lines or grids with fully integrated software for end to end add-on services. This technology provides the main connectivity in term of electrical and digital city platform that support network coverage and the accessibility of IoT devices in the most economic and efficient solution.



## Applications

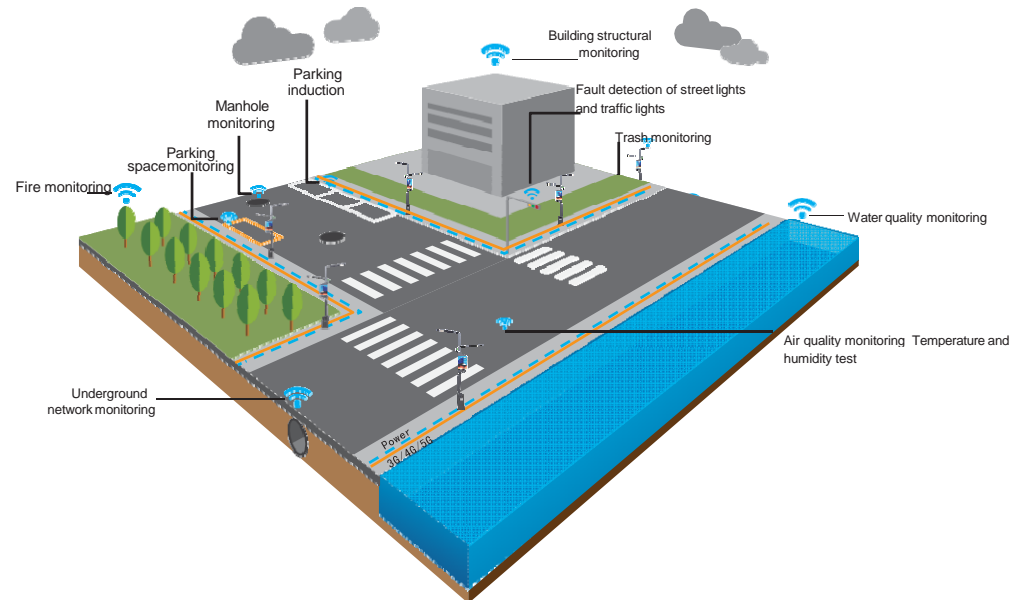
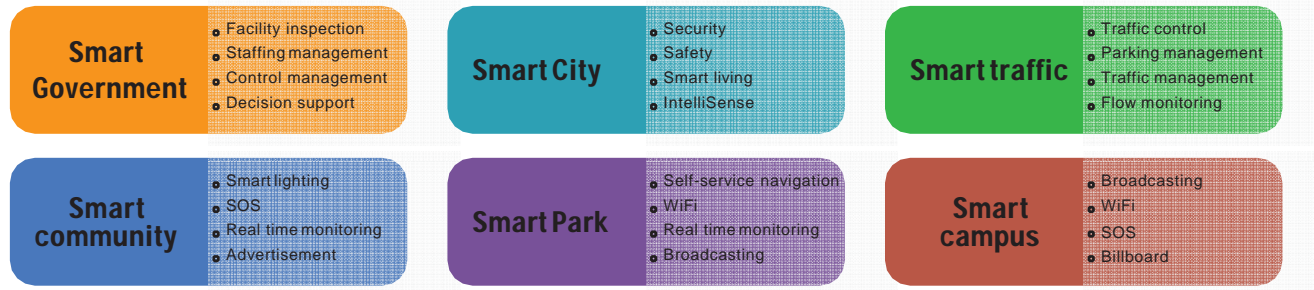

The transformation of the traditional streetlight from smart pole is empowered by broadband power line network. The public urban services can be easily deployed by getting a double access, digital and electrical platform on each pole with fully integrated software for end to end add-on services.

## LPT/ Watran - Smart City Solution & Services

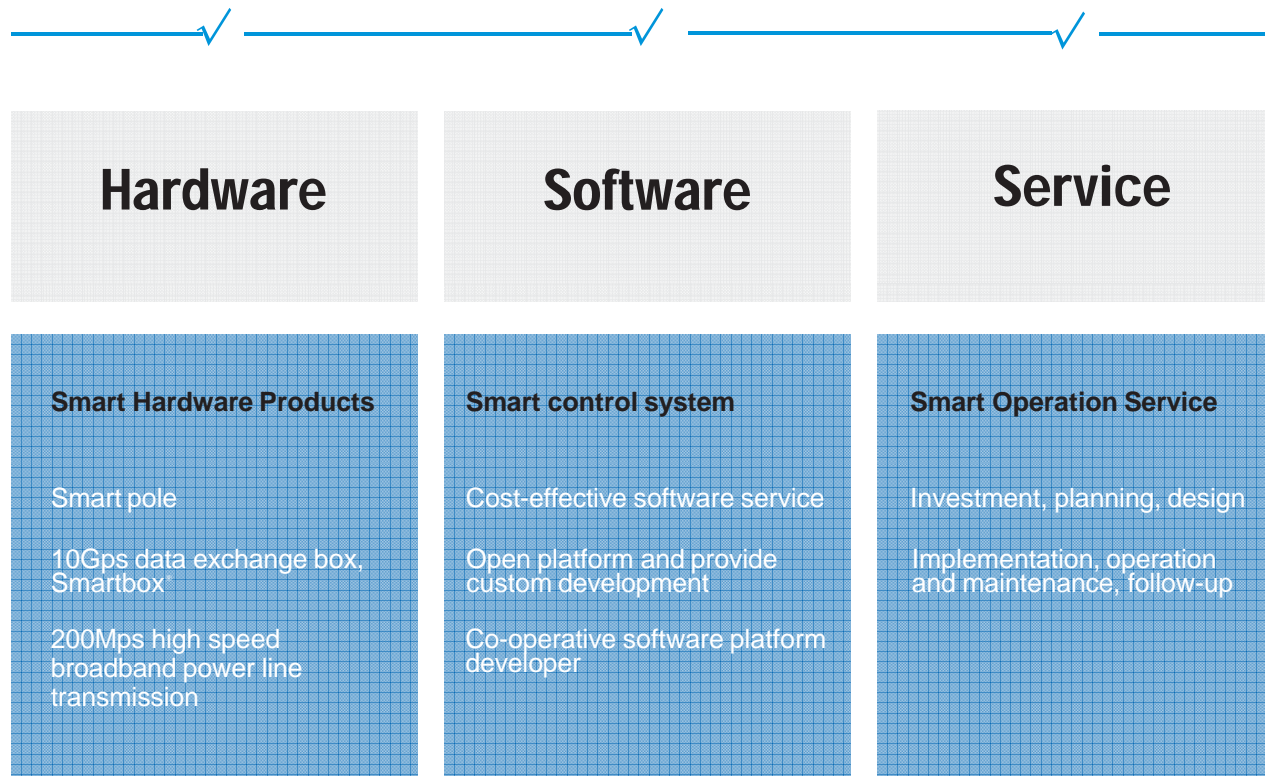

# Smart Street light

The Smart Pole can be configured on demand and intelligently integrated with Software as a Service( SaaS ) platform

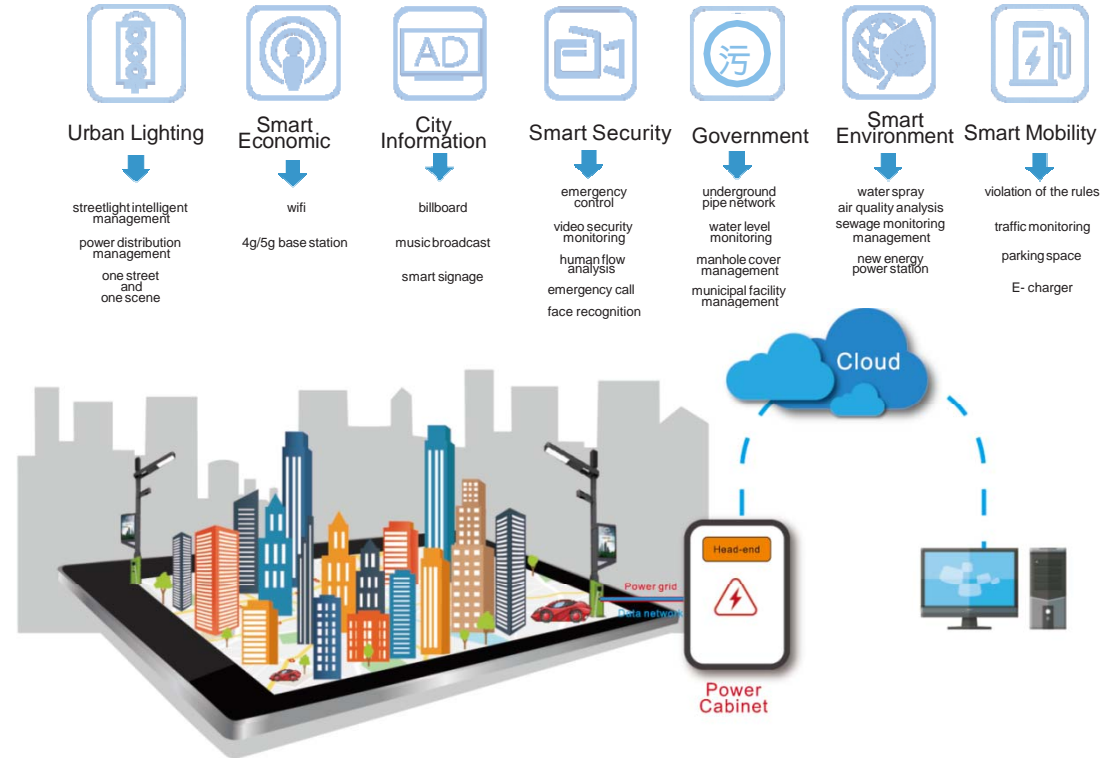

The smart poles are important public infrastructures which are located in every corner of the city. They provide comprehensive coverage of the city's geographical location and self-connected power resources. They are the best carrier for the layout of the interconnectivity city's Internet of Things and an excellent platform for the benefit of its inhabitants and business.

Watran's smart pole integrated streetlight and Internet of Thing, WiFi hot spot, video surveillance, environmental monitoring, SOS, information interaction, intelligent broadcasting, E-charger to transform into more interactive, responsive, and meeting the needs of all mankind, smart government, smart mobility, smart economic, smart people, smart living and smart environment.

# 10Gps City Data Exchange Box

## Smartbox®

10Gps city data exchange box, Smartbox® is a full feature high-end gateway with wide area network Gigabit Ethernet port which is ideal gateway for optic fiber network. Smartbox® with 4 LAN Gigabit Ethernet ports and one new generation Wi-Fi is the latest generation of gateway. Smartbox® can provide a high degree of digitalisation of the infrastructures that would need to link up with dispersed sensors, application specific devices and machines to create a reliable and sustainable network to transform the traditional streetlight into dynamic and resource-efficient platform.



**Smartbox®**

10Gps City Data Exchange Box

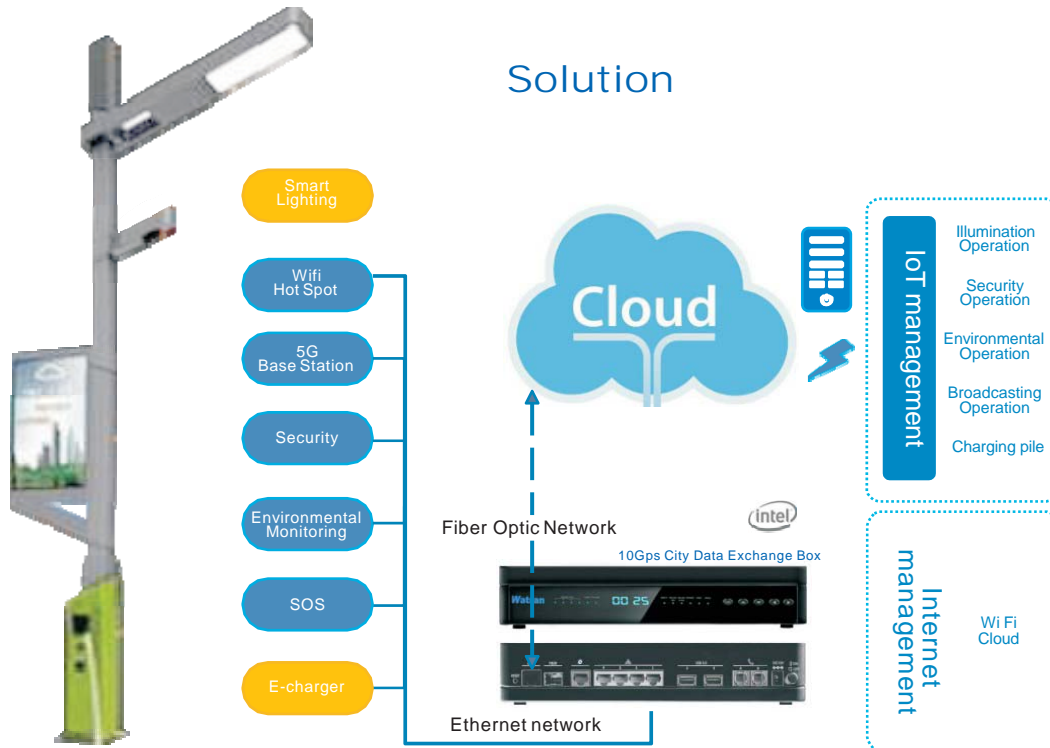

## 10Gps City Data Exchange Box characterises

1. All broadband flavor: Fiber (Point to Point/Gigabit-capable passive optical network, ethernet passive optical network, Copper: G.FAST) & Wide Area Network
2. Ethernet Gigabits switch with 4 port
3. 2 USB 3.0 ports for media storage
4. Latest wireless network WIFI 802.11. AC with 2SSIDs
5. Intel chip set technology

## Application

Smart Pole, SME

## BPL200Mps Broadband Power line Transmission - Solutions

BPL technology can provide a high-speed secure network, ensuring and optimizing bandwidth. The three main devices of BPL technology are connecting and transmitting broadband signals over existing power line grids and providing fully integrated software for end-to-end add-on services.

1. Headend is a device that sends and receives modulated wideband signals from a connected power network.
2. To further distribute the signal, a repeater amplifier can be deployed. The repeater communicates with the front end, repeaters, and endpoints.
3. Gateway is a terminal device that collects and distributes digital information.

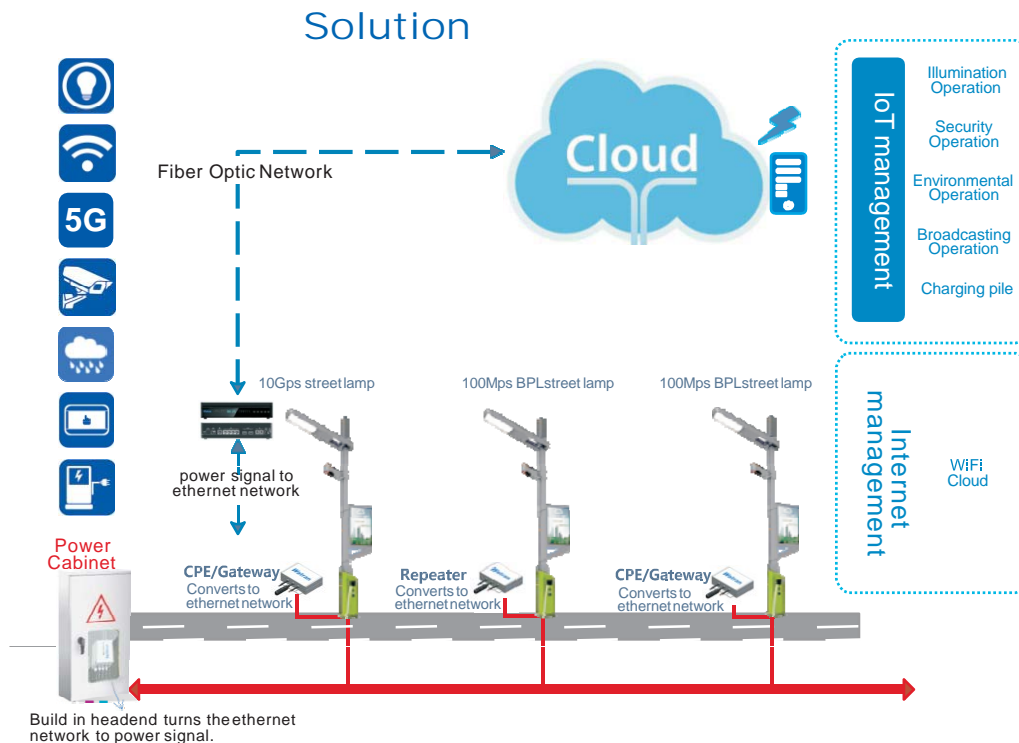

### System solution characteristics

1. Activate an electrical outlet (220V) and a broadband digital access point (up to 20 Mbit/s per point) on every single node.
2. Deploy urban services easily (WiFi, security, climate sensor, billboard) by reducing the civil works cost and sharing the telecom costs.
3. Ease of use, plug and play.
4. Enables to track the operating status of the high speed digital and electrical network and monitor each individual IoT devices remotely. 24/7 infrastructure supervision and operation on demand.
5. Multi-sources capacity, flexibility and scalability.

### Application

1. High speed internet access networks delivery (up to 200mbps) for the last mile
2. Real time energy management monitoring systems
3. Smart pole with control systems and data communication for multi-services (WiFi spot, speakers, CCTV cameras, emergency calls)
4. Smart home/ intelligent building automation
5. Smart grid & metering for data analytics



## BPL200Mps Broadband Power line Transmission - Solutions

### Hardware:

#### Headend

Model: HQEH10SWT



CHIP :DSS9503/DSS7800-DSS2718

### Headend (BPL main controller)

1. 110-400VAC, 100mA, 15W, one for each BPL line.
2. 1536 OFDM carriers carrying each from 2 to 10 bits depending on periodically estimated channel conditions.
3. Physical data rates up to 200Mbits/second on power lined channel conditions.
4. Network protocol TCP/IP-DHCP-TFTP-SNMP.
5. Standards are IEEE802.3u, 802. 1P, 802. 10
6. 1024 MAC address management and 15 maximum number of BPL nodes.
7. Direct connection to low voltage AC power line in a highly flexible manner with 1 reference and up to 3 differential pair with build in internal coupler.
8. Advance data security with AES packets encryption.

#### Repeater

Model: HQER10

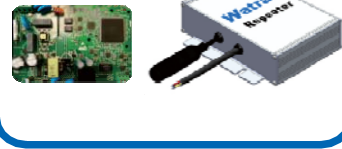

CHIP :DSS9503/DSS7800-DSS2718

### Repeater

1. 110-400VAC, 100mA, up to 8 per BPL line.
2. 1536 OFDM carriers carrying each from 2 to 10 bits depending on periodically estimated channel conditions.
3. Physical data rates up to 200Mbits/second on power line.
4. network protocol TCP/IP-DHCP-TFTP-SNMP.
5. Standards are IEEE802.3u, 802. 1P, 802. 10
6. 1024 MAC address management and 15 maximum number of BPL nodes.
7. IP TOS and 802.1Q priority tagging for quality of service on BPL network

#### CPE/Gateway

Model: HQEM10

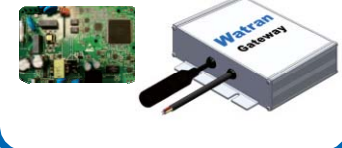

CHIP :DSS9503/DSS7800-DSS2718

### CPE/Gateway

1. 110-400VAC, 100mA, up to 15 per BPL line.
2. 1536 OFDM carriers carrying each from 2 to 10 bits depending on periodically estimated channel conditions.
3. Physical data rates up to 200Mbits/second on power line.
4. Network protocol TCP/IP-DHCP-TFTP-SNMP.
5. Standards are IEEE802.3u, 802. 1P, 802. 10.

## BPL200Mps Broadband Power line Transmission - Solutions

### Software Platform

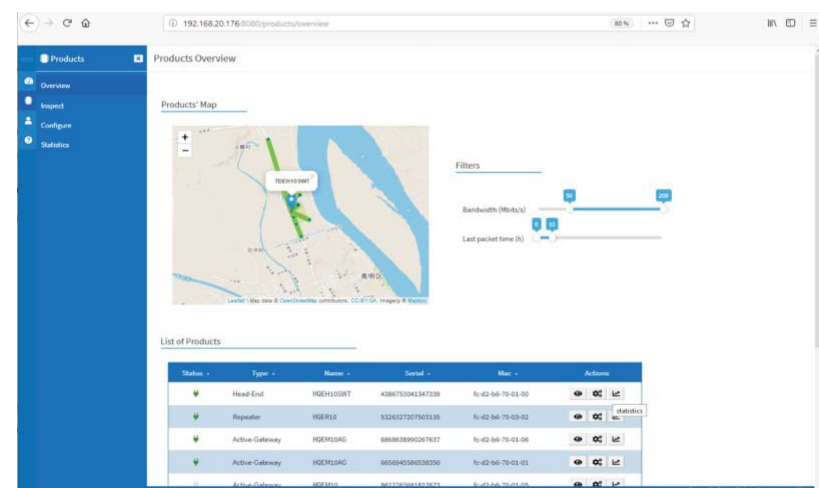
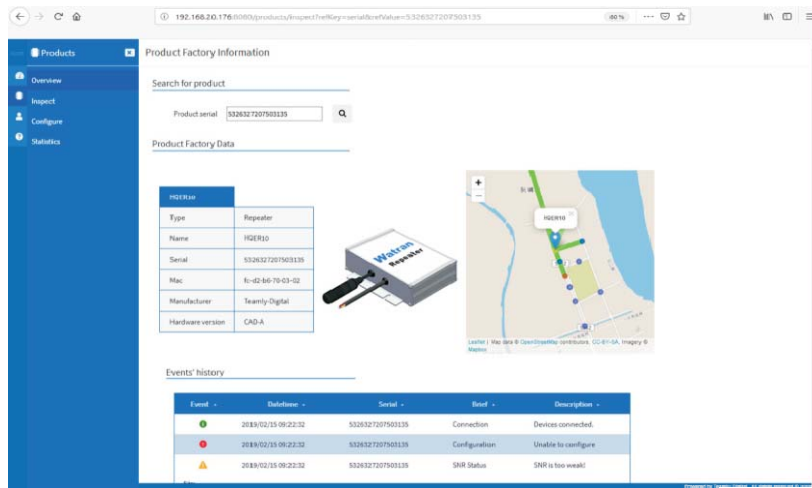
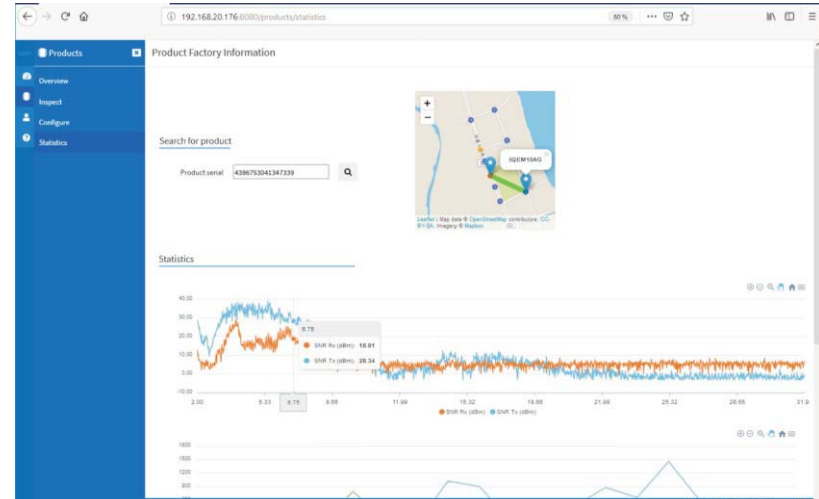
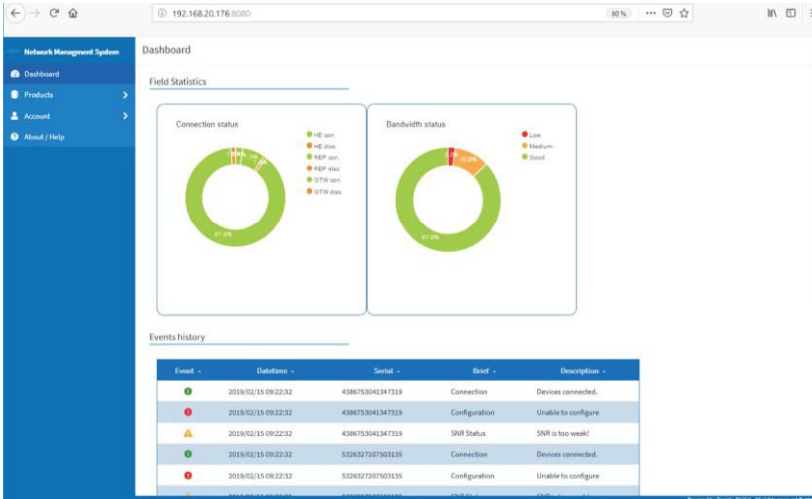

## Intelligent street light management system

Watran provides a complete smart lighting solution that creates a network over a city's power line. Watran uses 18 redundant channels with an additional wireless channel. Even if there is noise on some channels, redundancy with the other channels enables error free data transmission. This PLC+RF solution lays the foundation for a network to be implemented via the streetlight and power line infrastructure. This sustainable intelligent lighting network helps people build an efficient and dynamic, resource-efficient platform, realize remote management of lighting, intelligent control, improve the safety, convenience and comfort of lighting systems, and achieve an environment-friendly and energy-saving environment.

### System Solution

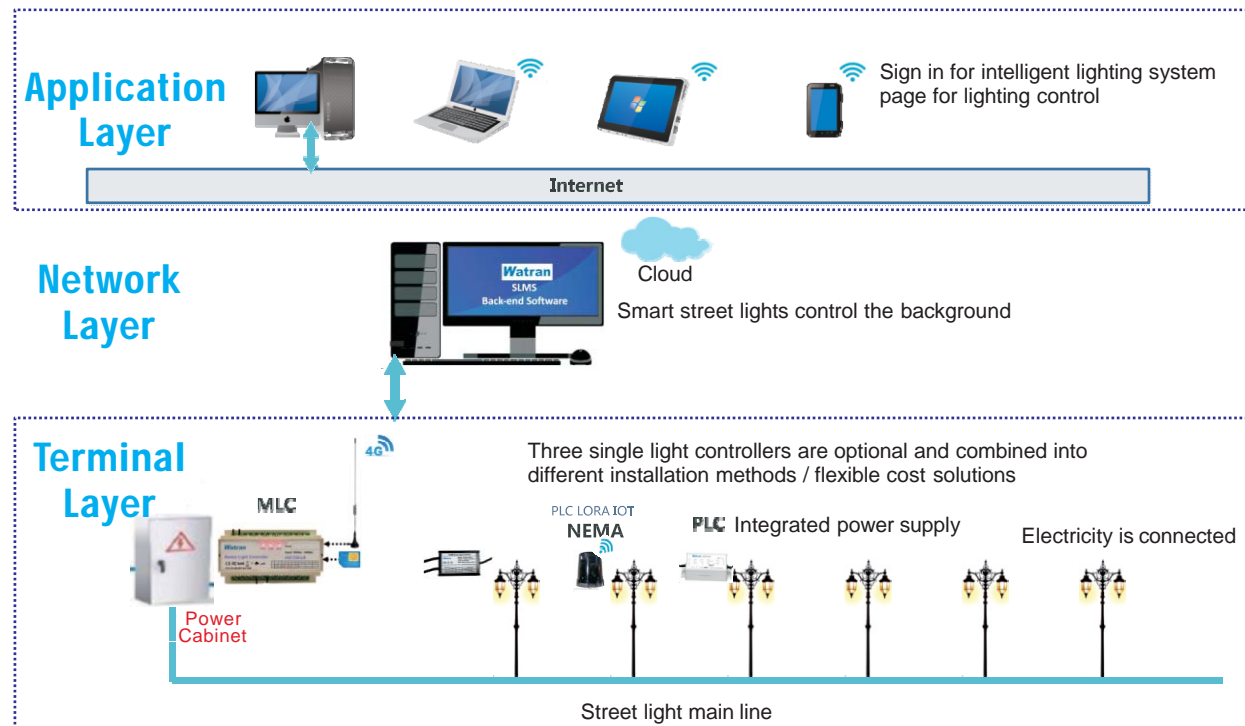

### System characteristics

1. A complete, real-time Streetlight management system that automatically dims and responds to environmental data which enables savings up to 40% on a city's electricity budget.
2. Cities can monitor streetlight infrastructure in real-time, proactively reacting to failures and breakages.
3. Future-proof compatibility with IoT technologies and 3rd party smart city apps.

### Software Platform

Street Light Management Software is the brain of the infrastructure, provides a platform to conveniently present critical information of a street light such as its operational status (on, off, dimming level, fault detection etc), its power consumption (eg. KWh, Voltage and Current) and its locality on a map etc. It also enables the user to set thresholds, alerts and schedule profiles based on the time of the day, season and local weather conditions. The Street Light Management Software operates in a cloud-based environment easily accessible from any PC or tablet.

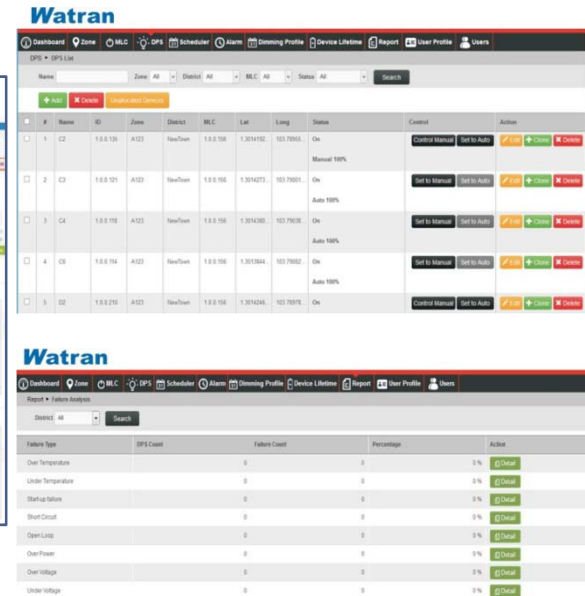
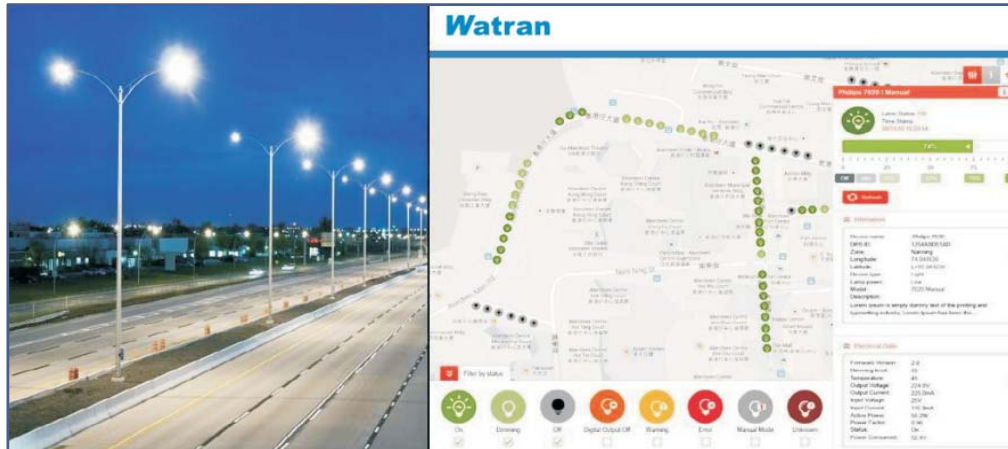

1. Performing real-time control of each street light or in zones, switching on or off or dimming.
2. Managing data collection such as the energy consumption and operational status of each street light.
3. Assigning Modbus IDs for each Digital Power Supply (DPS).
4. Configuring lighting zone membership, dimming profiles, and zone dimming schedules for the DPS's under the control of the Master Light Controller (MLC) being configured.
5. Configuring the inputs that are connected to the Master Light Controller (MLC). These inputs may be individually configured as level or edge-triggered in order to be used individually or in combinational logic with other inputs for conditional scheduling.
6. Configuring digital output and "No Polling" schedules.
7. Updating current clock time and the sunrise and sunset times for that day.
8. Configuring Master Light Controller (MLC) reporting schedules including alarm management.

## Intelligent street light management system

### Hardware



Model: HQ1338-LR

#### MLC (Main controller)

1. 100-240VAC/380VAC, 100mA, 50/60Hz, 2-10W.
2. 3-Phase Master Controller with 18 independent PLC channels operating with up to 54 out of 100 pre-installed carrier frequencies between 5kHz to 500 kHz.
3. Up to 2Km depends on power line conditions such as noise attenuation and load impedance.
4. One PLC master mode supports up to 100 PLC slave nodes.
5. Support RS-485 via a transparent protocol.



Model: HQ-SLC-500-P

#### SLC (Single light controller)

1. Wide input power voltage 90-277VAC, Input frequency 50/60Hz, Standby power<2W, IP65.
2. Light control output signal: 0-10Vm analog dimming, PWM compliant with IEC60929, DALI three-in-one dimming output.
3. Real-time data read-back such as power consumption, current, voltage and light status on the input side of the light driver.
4. Sending of system alerts to central management system.
5. Maximum light driver power support 500W.



Model: HQ-SLC-500-HN

#### NEMA (PLC Wired + LoRa Wireless Relay Terminal)

1. Wide input power voltage 90-277VAC, Input frequency 50/60Hz, Standby power<2W, IP65.
2. Light control output signal: 0-10Vm analog dimming, (optional PWM, DaLi).
3. Real-time data read-back such as power consumption, current, voltage and light status on the input side of the light driver.
4. Sending of system alerts to central management system.
5. Maximum light driver power support 500W.



#### Power Line Communication (PLC) Digital Power Supply

1. Wide input power voltage 90-277VAC, Input frequency 50/60Hz, Standby power<2W, IP65.
2. Support CV constant voltage, CC constant current output.
3. Real-time data read-back such as power consumption, current, voltage and light status on the input side of the light driver.
4. Available at 40W, 60W, 80W, 100W, 120W, 160W & 240W.

## Intelligent street light management system

### Technical advantages

Power line communications enables the most economic cost and most secure street light control approach. Competing power line solutions fail in noisy power line environments. Watran's solutions works reliability in noisy power lines as a result of its 18 redundant channel architecture and a radio frequency technology. Wireless solutions have much high cost as a result of monthly data charges (4G) or additional installed infrastructure (wireless repeaters). Watran uses existing, already paid for power line infrastructure. ZigBee and WiFi have problems of unreliable communication in outdoor use.



At present, the general PLC communication technology on the market is only two fixed at most frequency channel, Watran lighting solution uses 18 frequency channel, automatic frequency hopping technology, solving power interference issues.

In response to the above problems of communication, Watran has developed a unique set of multi-channel PLC communication technology, which uses 18 data repetitions channel, even if there is noise interference on some channels, other redundant channels can still carry out error-free data communication transmission.

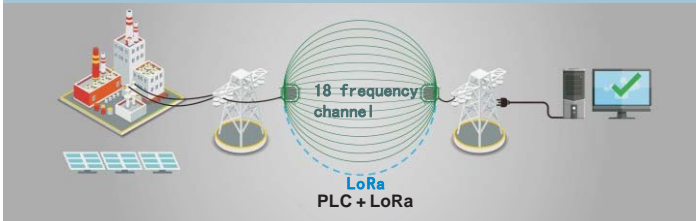

At the same time, in order to be able to communicate different power line networks and transformers, the 19th radio frequency has been installed. An extremely reliable and stable communication network can be achieved.

### Application



commercial



port



stadium



streetlight

## Bluetooth 5.0 automation system

Bluetooth mesh supports complex, many-to-many communication between various smart home and Internet of Things (IoT) devices so that any device in the mesh network can communicate with any other device in the network. Furthermore, devices do not have to be in direct radio range of each other. Messages are relayed across the network in a series of "hops", and networks can therefore span very large physical areas. Bluetooth mesh networking is a major step forwards to position across a range of new applications and industry sectors, including commercial & residential lighting. The mesh protocol stack uses Bluetooth LE for radio communications and inherits its power efficiency, low latency and other traits that have made Bluetooth LE so popular.

Watran's Bluetooth 5.0 lighting control and automation system that provides a cutting edge networked solution driving simplicity, scalability, and savings. Accelerate the return on investment while maximizing savings and enhancing the operational environment

### System Solution

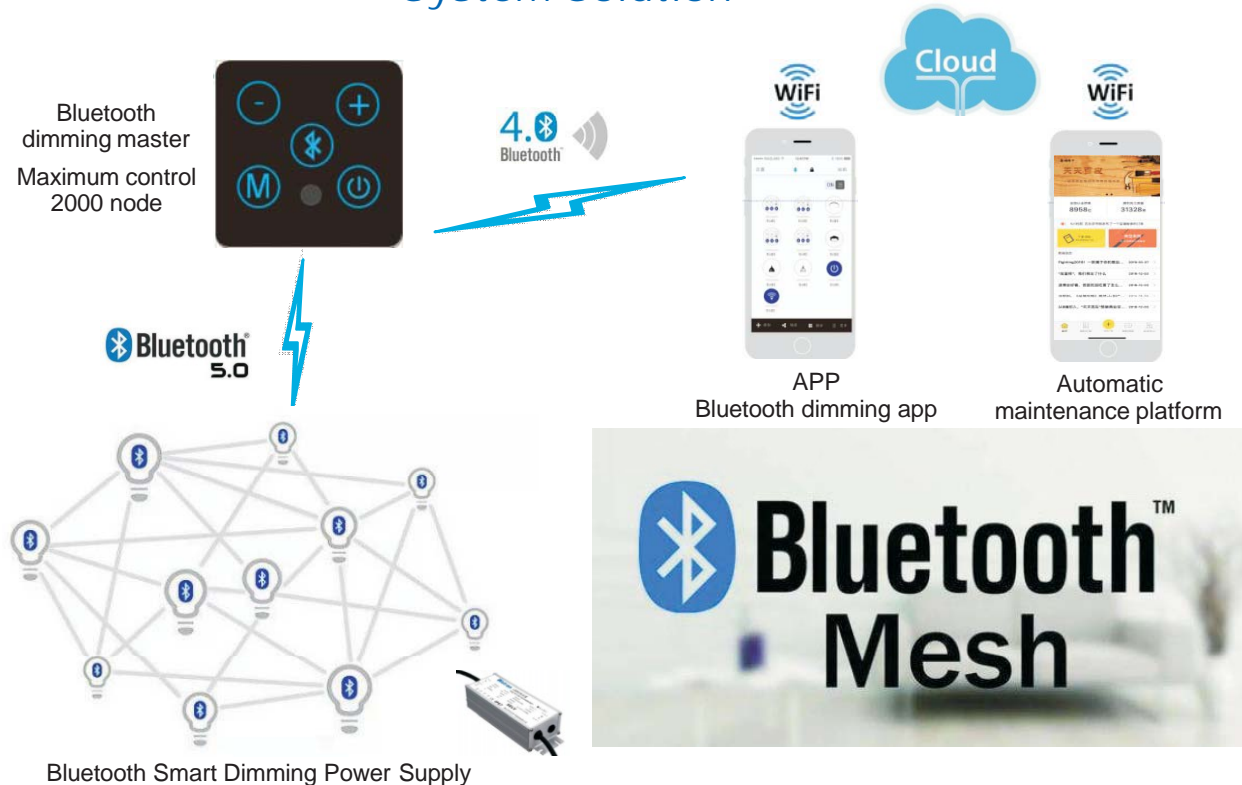

## Bluetooth 5.0 automation system

### System Features & Benefits

#### Intuitive Software



Easily set up and manage your lighting system with the Watran Software

#### Simple Installation



Mesh network ensures a simple and cost effective installation for existing retrofits and new construction projects

#### Daylight Harvesting



The system adjusts your lighting based on natural light levels, saving energy and costs

#### Task Tuning



Adjust light levels to optimize conditions in individual areas

#### Remote Access



Instant control from anywhere using the Watran Software

#### Granular Control



Greater energy savings via individualized control over specific areas

#### Maintenance scheduling



Real-time monitoring the photoelectric parameters of LED driver

#### Maintenance scheduling



Enhance savings and optimize an environment with customized schedules

### Application

Residential / Office / School / Hospitality / Shop & Retail





## DALI Lighting Management System

A worldwide standard (IEC 62386) in lighting control. DALI stands for Digital Addressable Lighting Interface. A DALI network consists of a controller with power supply and one or more slave devices (e.g., LED drivers) that have DALI interfaces. The controller can monitor and control each device by means of a bi-directional data exchange. The DALI bus can hold up to 64 devices, and has 16 groups and 16 scenes, and has a number of parameters that can be set. DALI is widely used in indoor lighting application.

### DALI master



The DALI master controller developed by Watran has 1 output, each channel has 64 addresses, 64 addresses can be divided into 8 zones, each zone can control 8 lights, and the luminaires connected to it can be controlled by addressing. Buttons on the touch surface controller can control dimming of the luminaires, supporting the respective mobile phone APP software, enables wireless communication handset docking with the controller. In applications, the mobile APP can control the 16 DALI masters. The lamp can be adjusted through software monochrome brightness and colour temperature adjustment. At the same time, one can also customize the address, single luminaires control, or multi-lamp linkage control.



Mobile APP



Bluetooth



DALI master



DALI dimmable luminaire

The system consists of three parts: the mobile APP, the DALI master and DALI dimming fixtures. The mobile APP operating interface and the DALI master are transmitted through Bluetooth, transmitting & receiving data information. The system has two application modes:

1. Single light source brightness adjustment.
2. Two-colour temperature and colour temperature adjustment. The working mode of the main controller can be defined by the APP control panel, different scenes and control modes can be set.

## DALI Lighting Management System

### System application diagram

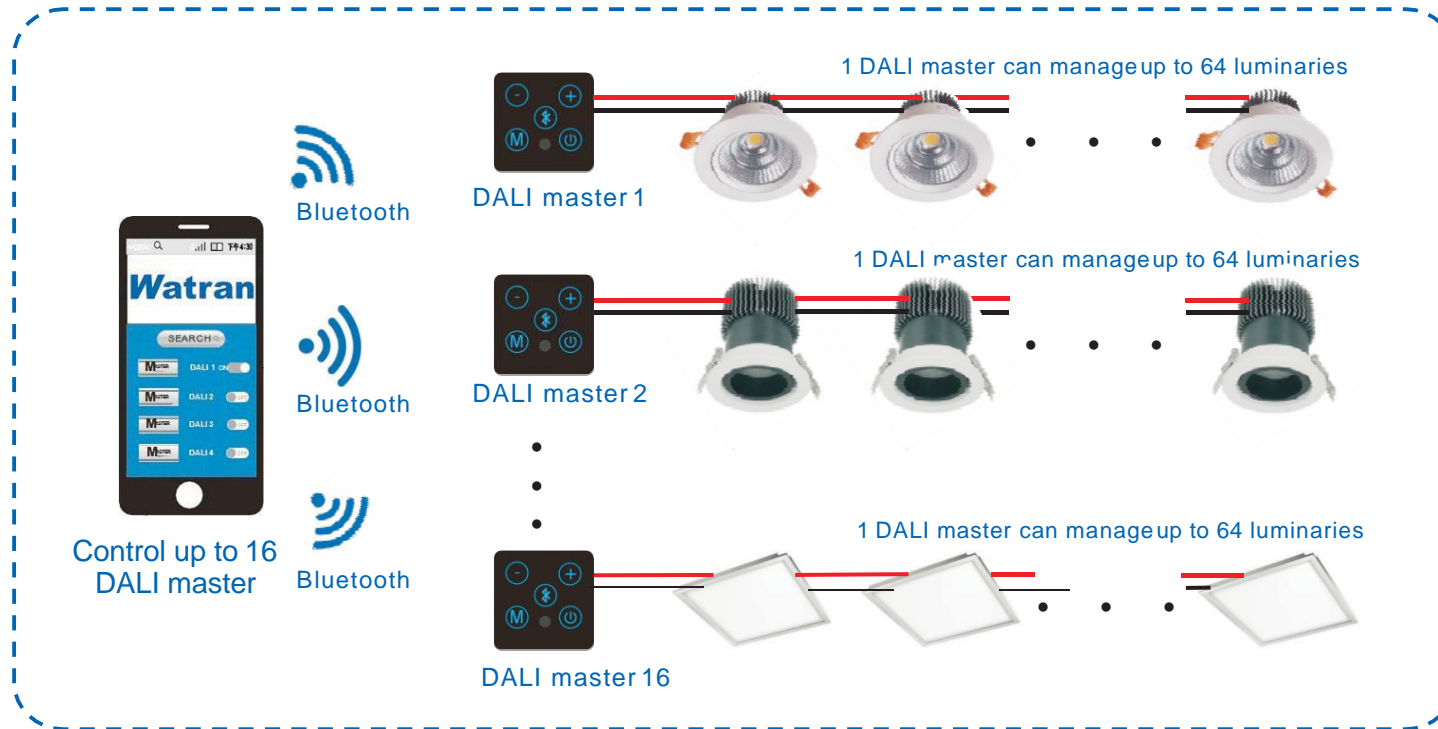

## DMX512 lighting control system

Digital Multiplex (DMX512) is an international standard for digital communication networks that are commonly used to control stage lighting and effects. It soon became the primary method for linking controllers to dimmers and special effects devices and intelligent lights. DMX has also expanded to uses in non-theatrical interior and architectural lighting, at scales ranging from strings of Christmas lights to electronic billboards. DMX can now be used to control almost anything, reflecting its popularity in theatres and venues.

### DMX512 lighting control system

It is composed of DMX512 main controller, DMX512 controller, supporting change effect software, etc.



### System application connection

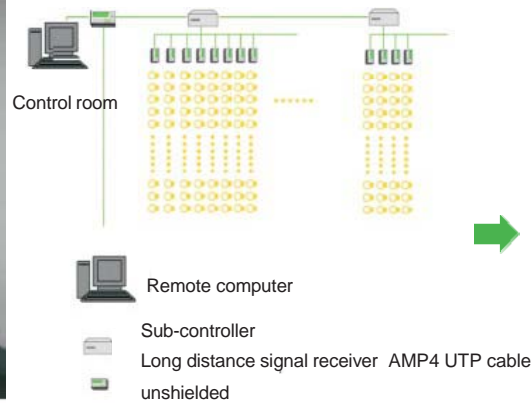
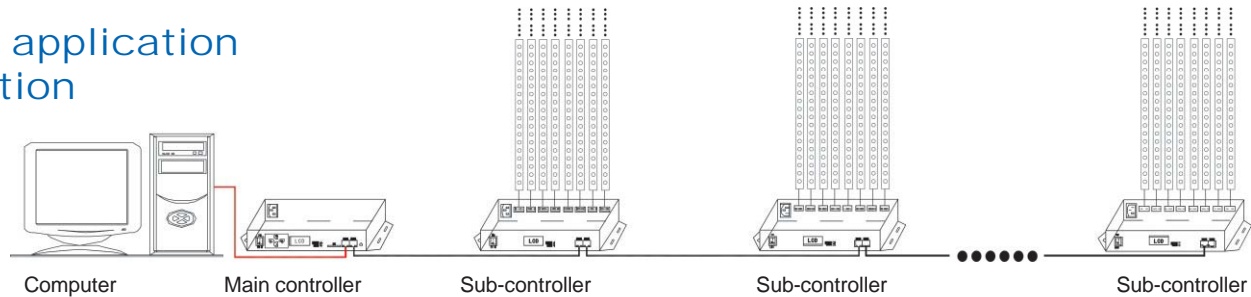

Application



## COMPANY PROFILE

**Watran**  
light from the heart

**1986**

Watran was founded in 1986 by Mr. Yuzhu Ou, is located at Foshan City, Guangdong Province. Its business was mainly on traditional accessories of lamp.



**2001**

Later on, the traditional ballasts, ignitor, capacitors, lighting products was further expanded OEM to the 1<sup>st</sup> tier lighting companies



**2008**

In addition, the new factory was built to cope with the OEM suppliers demand while the old factory remained to supply the electronic products. CNL was founded by two brothers for the lighting project solution business

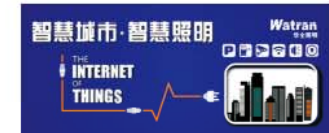

**1997**

Second generation, Mr. ZhiQuan, Ou and Mr. ZhiYang, Ou was taken up the company direction and strategy.

**1999**

Ballast for HPS was developed and the inductive Ballast was first ODM to Schneider Electric.

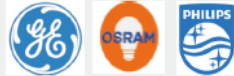

**2006**

The transition of the lighting industry from traditional to LED. Watran was heavily invested in technology knowhow and production facilities for LED driver and LED outdoor luminaires.



**2016**

Today, the core competence is focused on the broadband access technology for the benefit of its inhabitants and business.



## Strategic Technology and Business Partners of Watran & Teamly Digital

Teamly Digital specializes in the design and development of advanced communication system solutions, while Watran has world-class manufacturing capabilities. Watran and TD jointly developed advanced technology solutions for immediate use for high-speed broadband access that is compatible with existing communications infrastructure. This partnership provides customers with economical solutions (hardware and application software) with high quality standards and superior performance, including proof of concept/validation, system design and system configuration.

# COMPANY PROFILE

## Advanced production equipment

Watran has the world's advanced manufacturing equipment, automation, smart chemical plants



## Other business products

LED drives、LED lamps、HID ballast、HID lamps

# Project cases

**CASE**







**Taiwan. China**

Technology:  
PLC Smart  
Street Light System

**CASE**

**Spain**



**BPL200Mps Broadband Power line Transmission**

**CASE**

**Singapore airport**

PLC Smart  
Street Light System



**KPI 1 : Operational modes of SLMS**

- Regular monitoring of SLMS:
  - General SLMS operations
  - Scheduling
  - Active values of smart lamps : voltages, current
  - Incidents of failures : Smart lamps, SLCS, MLC

**KPI 2 : Power consumptions for August**

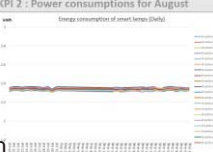
(Average consumption of smart street lighting)







With SLCS

**CASE**

**France  
(Grand Dijon)**

**BPL200Mps Broadband  
Power line Transmission**



**CASE**

**French (Seine)**

**BPL200Mps Broadband  
Power line Transmission**



**CASE**

**France  
(Valenciennes)**

**BPL200Mps Broadband  
Power line Transmission**



**CASE**

**Guangzhou**

**DMX512 + RDM system**



**Lighting and Power**  
Technologies LLC

Smart life  
makes life better

**Watran**



[www.lightingandpowertech.com](http://www.lightingandpowertech.com)

