

TIMKEN

Where You Turn



Timken Bearing Damage
Analysis with Lubrication
Reference Guide

 **WARNING** *Failure to observe the following warnings could create a risk of serious injury.*

Never spin a bearing with compressed air. The rollers may be forcefully expelled.

 **WARNING** *Failure to observe the following warnings could create a risk of serious injury.*

Proper maintenance and handling procedures are critical. Always follow installation instructions and maintain proper lubrication.

 **WARNING** *Failure to observe the following warnings could create a risk of serious injury.*

Tensile stresses can be very high in tightly fitted bearing components. Attempting to remove such components by cutting the cone (inner race) may result in a sudden shattering of the component causing fragments of metal to be forcefully expelled. Always use properly guarded presses or bearing pullers to remove bearings from shafts, and always use suitable personal protective equipment, including safety glasses.

DISCLAIMER

Every reasonable effort has been made to ensure the accuracy of the information contained in this writing, but no liability is accepted for errors, omissions or for any other reason.



Introduction

Timken stands behind its products and the customers it serves. Whether training a team of maintenance personnel on proper bearing installation in the Powder River Basin area of Wyoming or providing application engineering assistance from our technology center in Bangalore, India, Timken friction management knowledge and expertise spans the globe, supporting major industries.

More than 100 years of expertise in material science and tribology, along with our long history of being a quality steel manufacturer, makes Timken uniquely qualified in bearing damage analysis. Our sales and service teams are trained to both assess bearing damage issues on site, as well as work with customers to offer preventive maintenance techniques to improve performance.

The purpose of this reference guide is to help maintenance and operations personnel identify some of the more common types of bearing damage, explain possible causes and discuss corrective actions. In many cases, the bearing damage may be due to a combination of causes. This guide also contains useful bearing references and lubrication guidelines.

For more information on bearing damage analysis, contact your Timken sales or service engineer, or visit www.timken.com.



Table of Contents

| | |
|---|----|
| Preparation and Approach to Bearing Damage Analysis | 6 |
| Types of Bearing Damage | |
| Wear – Foreign Material | 7 |
| Abrasive Wear | 7 |
| Pitting and Bruising | 8 |
| Grooving | 8 |
| Debris Contamination | 8 |
| Etching – Corrosion..... | 9 |
| Inadequate Lubrication | 10 |
| Fatigue Spalling | 12 |
| Excessive Preload or Overload | 13 |
| Excessive Endplay | 14 |
| Misalignment and Inaccurate Machining of Seats and Shoulders | 14 |
| Handling and Installation Damage | 15 |
| Damaged Bearing Cages or Retainers..... | 16 |
| High Spots and Fitting Practices..... | 17 |
| Improper Fit in Housings or Shafts | 18 |
| Brinell and Impact Damage | 19 |
| False Brinelling | 20 |
| Burns from Electric Current..... | 21 |
| Cam Fracture | 21 |
| | |
| Understanding Bearing Life | |
| Bearing Service Life..... | 22 |
| | |
| Lubrication Reference Guide | |
| Factors that Impact Lubrication Performance | 23 |
| Lubrication Guidelines – Required Grease Quantity | 26 |
| | |
| Glossary | 27 |
| | |
| Types of Bearings and Nomenclature | 29 |
| | |
| Tapered Roller Bearing Speed Capability Guidelines | 30 |
| | |
| Temperature Guidelines for Roller Bearing Installation | 31 |
| | |
| Cone Bore Growth Expansion Rates | 32 |
| | |
| Conversion Equivalents for U.S. and Metric Measurements | 33 |
| | |
| Conversion Chart Showing Millimeter, Fractional and Decimal Inch Sizes | 34 |
| | |
| Temperature Conversion Table | 35 |
| | |
| Friction Management Solutions® | 36 |

Reference the Timken Industrial Bearing Maintenance Manual for additional information.

Preparation and Approach to Bearing Damage Analysis

Bearing Damage: Overview of the Facts

More than 50 percent of bearings that are submitted to Timken bearing service and repair specialists have not reached their calculated lives. In some cases, it's caused by contact fatigue (inclusion origin, point surface origin, geometric stress concentration and micro-spalling). In 90 percent of the cases, though, it's caused by non-fatigue factors, including:

- Foreign materials
- Corrosion
- Inadequate lubrication
- Improper handling
- Bad running conditions

If you're concerned that your bearing is deteriorating, look for the following signs:

- **Vibrations – whether felt by hand or measured with a frequency analyzer**
- **Abnormal noises**
- **Displacement of rotational centerline**
- **Running temperature increase**
- **Odd smells**
- **Lubricant deterioration**
- **Lubricant leakage**
- **Visual discovery during routine maintenance check**

Bearing Analysis

For an accurate and complete analysis, the following steps should be taken when investigating bearing damage and system breakdowns. For assistance with bearing damage analysis, contact a Timken sales or service engineer.

1. Obtain operating data from bearing monitoring devices; analyze service and maintenance records and charts; and secure application diagrams, graphics or engineering drawings.
2. Prepare an inspection sheet to capture all observations. Take photographs throughout the procedure to assist documentation or description of damaged components.
3. Extract used lubricant samples from bearings, housing and seal areas to determine lubricant conditions. Package separately and label properly.
4. Secure a sample of new, unused lubricant. Record any specification or batch information from the container. Obtain technical specifications and any related material safety data (handling, disposal, toxicological) documentation to accompany lubricant shipments.
5. Check bearing environment for external influences, including other equipment problems that preceded or were occurring at the time bearing damage was reported.
6. Disassemble equipment (either partially or completely). Record an assessment of the mounted bearing condition.
7. Inspect other machine elements, in particular the position and condition of components adjacent to the bearing, including locknuts, adapters, seals and seal wear rings.
8. Mark and record the mounted position of bearings and components prior to removal.
9. Measure and verify shaft and housing size, roundness and taper using certified gauges.
10. Following removal, but before cleaning, record observations of lubricant distribution and condition.
11. Clean parts and record manufacturers' information from marking on the bearing rings (part number, serial number, date code).
12. Analyze condition of the internal rolling contact surfaces, load zones and the corresponding external surfaces.
13. Apply preservative oil and repackage bearings to avoid corrosion.
14. Compile a summary report of all data for discussion with Timken sales or service engineers.

Types of Bearing Damage

Bearing damage can occur as a result of a number of different operating conditions. Those listed in this section are the most commonly found for anti-friction bearings, including cylindrical, spherical, tapered and ball designs. It is important to remember that proper bearing maintenance and handling practices are critical to ensure optimum performance.

Wear – Foreign Material

One of the most common sources of trouble in anti-friction bearings is wear and damage caused by foreign particles. Foreign particle contamination can cause abrasive wear, bruising and grooving, circumferential lining or debris contamination.

Abrasive Wear

Fine foreign material in the bearing can cause excessive abrasive wear. Sand, fine metal from grinding or machining, and fine metal or carbides from gears will wear or lap the rolling elements and races. In tapered bearings, the roller ends and cone rib will wear to a greater degree than the races. This wear will result in increased endplay or internal clearance, which can reduce fatigue life and result in misalignment in the bearing. Abrasive wear also can affect other parts of the machine in which the bearings are used. The foreign particles may get in through badly worn or defective seals. Improper initial cleaning of housings and parts, ineffective filtration or improper filter maintenance can allow abrasive particles to accumulate.

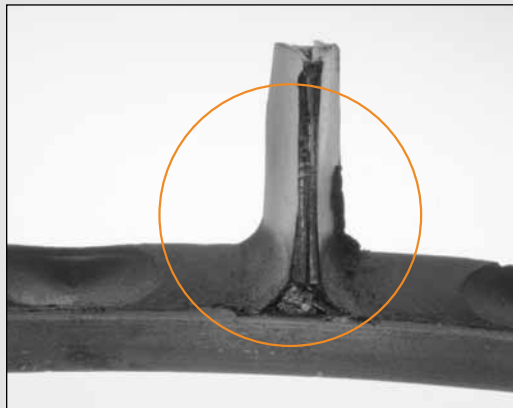

Fig. 1. Fine particle contamination entered this spherical roller bearing and generated wear between the cage surfaces, rollers and races.

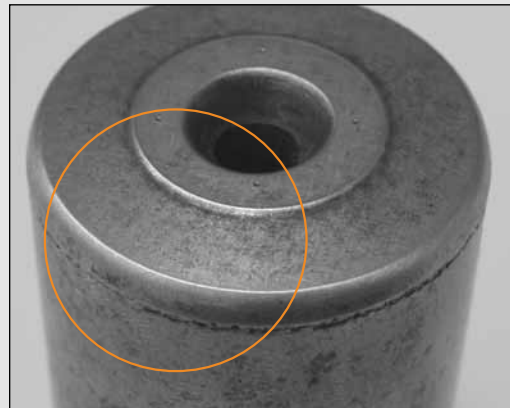

Fig. 2. The roller end wear on this spherical bearing also was caused by fine particle contamination.



Fig. 3. (left) Fine particle contamination caused abrasive wear on this tapered roller bearing.

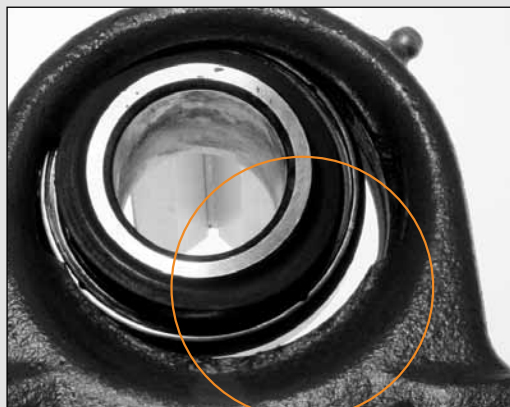
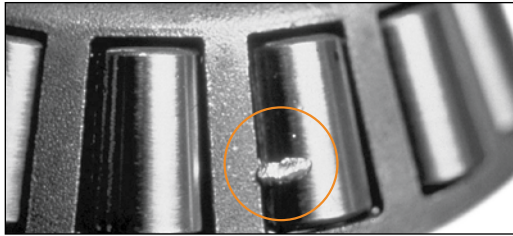

Fig. 4. (right) Exposure to abrasives and water in a severe environment caused extreme wear on this pillow block bearing.

Pitting and Bruising

Hard particles rolling through the bearing may cause pitting and bruising of the rolling elements and races. Metal chips or large particles of dirt remaining in improperly cleaned housings can initiate early fatigue damage.



Grooving

Grooving is caused by extremely heavy wear from chips or metal particles. These contaminants become wedged in the soft cage material and cause cut grooves in the rolling elements. This condition results in improper rolling contact geometry and can reduce service life.

Fig. 5. Large particle contamination imbedded into the soft cage material can result in grooving.

Debris Contamination

Common causes of external debris contamination include dirt, sand and environmental particles. Common causes of internal debris contamination include wear from gears, splines, seals, clutches, brakes, joints, housings not properly cleaned, and damaged or spalled components. These hard particles travel within the lubrication, through the bearing and eventually bruise (dent) the surfaces. Raised metal around the dents that act as surface-stress risers cause premature spalling and reduced bearing life.

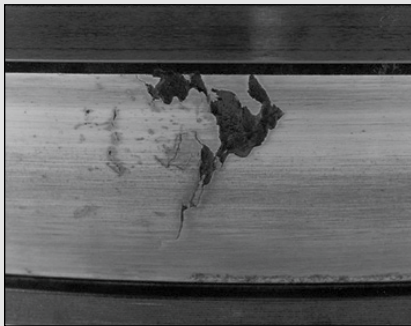

Fig. 6. A tapered roller bearing inner race (cone) with spalling from debris contamination bruises.

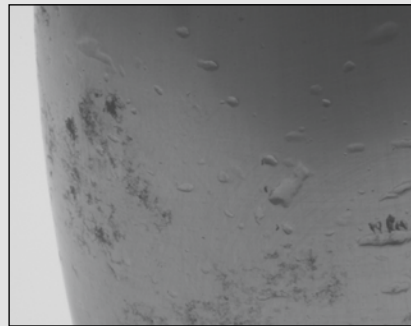

Fig. 7. Hard particles caused contamination bruising on this spherical roller bearing.

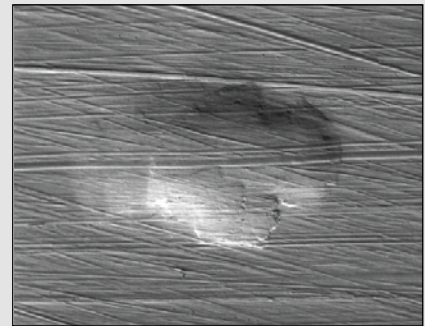

Fig. 8. This photo, taken with a microscope, shows a debris contamination bruise on a bearing race. A corresponding surface map of the dent is shown below in Fig. 10.



Fig. 9. Debris from other fatigued parts, inadequate sealing or poor maintenance caused bruising on this tapered roller bearing race.

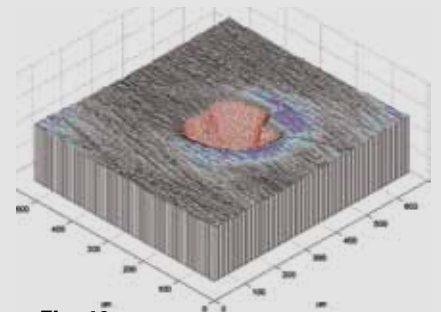

Fig. 10.

Etching – Corrosion

Etching or corrosion is one of the most serious problems encountered in anti-friction bearings. The high degree of surface finish on races and rolling elements makes them susceptible to corrosion damage from moisture and water if not adequately protected.

Etching is most often caused by condensate collecting in the bearing housing due to temperature changes. The moisture or water oftentimes gets in through damaged, worn or inadequate seals. Improper washing and drying of bearings when they are removed for inspection also can cause considerable damage. After cleaning and drying or whenever bearings are put into storage, they should be coated with oil or another preservative and wrapped in protective paper. Bearings, new or used, should always be stored in a dry area and kept in original packaging to reduce risk of static corrosion appearing before mounting.

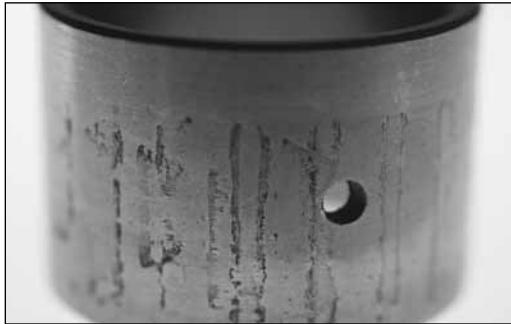

Fig. 11. This cylindrical bearing inner ring has etching and corrosion.



Fig. 12. This cup has heavy corrosion on the race. This type of corrosion may only be a surface stain without pitting. If the staining can be cleaned with a fine emery cloth or crocus cloth, the bearing may be reused. If there are pits that cannot be cleaned with light polishing, the bearing should either be discarded or, if practical, refurbished.



Fig. 13. Advanced spalling initiated at water etch marks on the cup race makes this bearing unsuitable for further service.



Fig. 14. Heavy water damage is shown on this ball bearing inner ring and cage.



Fig. 15. This ball bearing outer race also depicts etching and corrosion.

Inadequate Lubrication

Inadequate lubrication can create a wide range of damage conditions. Damage happens when the lubricant intended for a bearing is not sufficient to separate the rolling and sliding contact surfaces during service.

It is very important that the right lubricant amount, type, grade, supply system, viscosity and additives be properly engineered for each bearing system. The correct selection is based upon history, loading, speeds, sealing systems, service conditions and expected life. Without proper consideration of these factors, less than adequate bearing and application performance may be expected.

The damage caused by inadequate lubrication varies greatly in both appearance and performance. Depending on the level of damage, it may range from very light heat discoloration to total bearing lockup with extreme metal flow.

The section below demonstrates the progressive levels of bearing damage caused by inadequate lubrication:

Level 1 – Discoloration

- Metal-to-metal contact results in excessive bearing temperature.
- High temperatures result in discoloration of the races and the roller.
- In mild cases, the discoloration is from the lubricant staining the bearing surfaces. In severe cases, the metal itself is discolored from high heat.

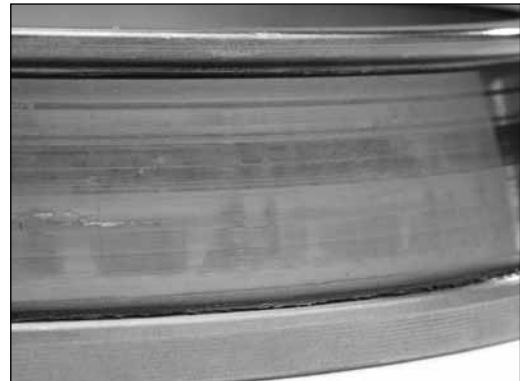

Fig. 16. Level 1 – Discoloration due to elevated operating temperatures.

Level 2 – Scoring and Peeling

- Insufficient or complete lack of lubricant.
- Selecting the wrong lubricant or lubrication type.
- Temperature changes.
- Sudden changes in running conditions.



Fig. 17. Level 2 – Micro-spalling or peeling was the result of thin lubricant film from high loads/low RPM or elevated temperatures.



Fig. 18. Level 2 – Advanced rib scoring due to inadequate lube film.

Level 3 – Excessive Roller End Heat

- Inadequate lube film results in localized high temperatures and scoring at the large ends of the rollers.

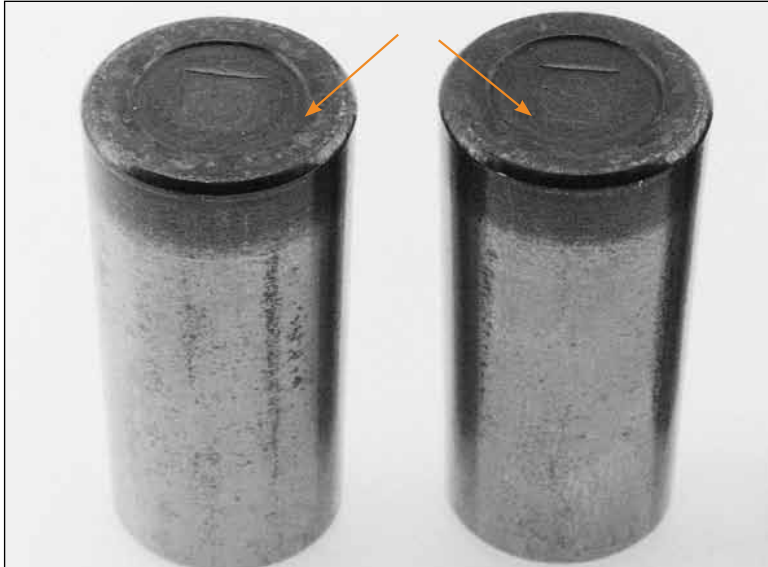

Fig. 19. Level 3 – Heat damage on these tapered rollers was caused by metal-to-metal contact.

Level 4 – Total Bearing Lockup

- High localized heat produces metal flow in bearings, altering the original bearing geometry and the bearing's material.
- This results in skewing of the rollers, destruction of the cage, metal transfer and complete seizure of the bearing.



Fig. 20. Level 4 – Excessive heat generation caused advanced metal flow of the rollers, as well as cone rib deformation and cage expansion.



Fig. 21. Level 4 – Total bearing lockup is depicted here.

Careful inspection of all bearings, gears, seals, lubricants and surrounding parts may help determine the primary cause of damage. See the Lubrication Reference Guide on page 23 to learn more about how lubrication conditions impact bearing performance.

Fatigue Spalling

Spalling is simply defined as the pitting or flaking away of bearing material. Spalling primarily occurs on the races and the rolling elements. It is important to realize that there are many types of “primary” bearing damage shown throughout this reference guide, and they will eventually deteriorate into a secondary damage mode of spalling. Timken classifies three distinct spalling damage modes:

Geometric Stress Concentration (GSC) Spalling

This mode is the result of misalignment, deflection or edge loading that initiates high stress at localized regions of the bearing (Fig. 22). The damage occurs at the extreme edges of the race/roller paths. It also can be the end result of machining errors with the shaft or the housing.



Fig. 22. Misalignment, deflections or heavy loading on this tapered roller bearing caused GSC spalling.



Point Surface Origin (PSO) Spalling

This mode is the result of very high and localized stress (Fig. 23). The spalling damage is typically from nicks, dents, debris, etching and hard-particle contamination in the bearing. PSO spalling is the most common spalling damage, and it often appears as arrowhead shaped spalls, propagating in the direction of rotation.

Fig. 23. PSO spalling resulted from debris or raised metal exceeding the lubricant film thickness on this tapered roller bearing inner ring.

Inclusion Origin Spalling

This is the result of bearing material fatigue at localized areas of sub-surface, non-metallic inclusions, following millions of load cycles. The damage is observed in the form of localized, elliptically shaped spalls. Bearing steel cleanliness has improved over the past two decades to the extent that this type of spalling is seldom encountered.



Fig. 24. Heavy spalling and fracturing from high loads on this spherical roller bearing.



Fig. 25. High loads resulted in fatigue spalling on this cylindrical roller bearing.



Fig. 26. This ball bearing inner ring depicts fatigue spalling from high loads. The fracture is a secondary damage mode.

Excessive Preload or Overload

Excessive preload can generate a large amount of heat and cause damage similar in appearance to inadequate lubrication damage. Often the two causes may be confused, so a very thorough check is required to determine the root problem. A lubricant that is suitable for normal operation may be unsuitable for a heavily preloaded bearing, as it may not have the film strength to carry the very high loads. The breakdown of lubricant caused in high preloads can cause the same type of damage as shown in the previous description of inadequate lubrication damage discussed on page 10.

Another type of damage can result from heavy preloads, even if a lubricant, such as an extreme pressure type of oil that can carry heavy loads, is used. Although the lubricant can take care of the loads so that no rolling element or race scoring takes place, the heavy loads may cause premature sub-surface fatigue spalling. The initiation of this spalling, and subsequently the life of the bearing, would depend upon the amount of preload and the capacity of the bearing.



Fig. 27. Overloading on this cylindrical roller bearing caused roller surfaces to fracture.



Fig. 28. High loads and low speeds caused insufficient lubricant film on this tapered roller bearing cone.

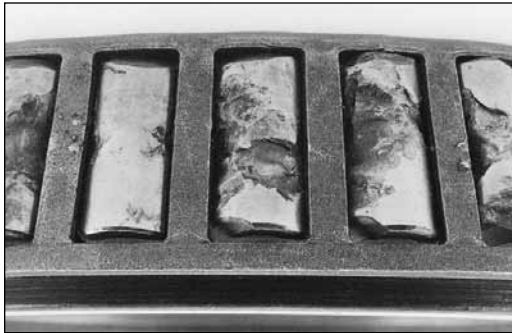

Fig. 29. A heavily overloaded tapered roller bearing resulted in premature, severe fatigue spalling on the rollers. The load was so heavy that large pieces of metal broke off the rollers.

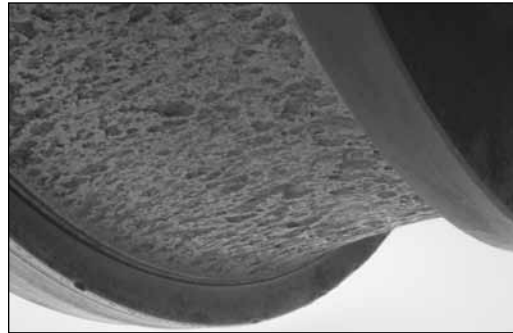

Fig. 30. Severe peeling and spalling is shown on this spherical bearing race, also resulting from high loads.

Excessive Endplay

Excessive endplay results in a very small load zone and excessive looseness between the rollers and races outside the load zone. This causes the rollers to be unseated, leading to roller skidding and skewing as the rollers move into and out of the load zone. This movement causes scalloping in the cup race and cage wear from excessive roller movement and the impact of the rollers with the raceway.



Fig. 31. Scalloping marks in the cup race are common with excessive endplay. Unloaded rollers enter the small load zone and are suddenly exposed to heavy loads.



Fig. 32. Cage pocket damage from excessive roller movement.



Fig. 33. Heavy wear in the small end of the cage pockets is typical of excessive endplay.

Misalignment and Inaccurate Machining of Seats and Shoulders

Misaligned bearings will shorten bearing life. The reduction in service will depend on the degree of misalignment. To get full life from the bearing, the seats and shoulders supporting the bearing must be within specified limits set by the bearing manufacturer. If the misalignment exceeds the limits, the load on the bearing will not be distributed along the rolling elements and races as intended, but will be concentrated on only a portion of the rollers or balls and races. In cases of extreme misalignment or off angle, the load will be carried only on the extreme ends of the rolling elements and races.

A heavy concentration of the load and high stresses at these points will result in early fatigue of the metal.

Causes of misalignment:

- Inaccurate machining or wear of housings or shafts
- Deflection from high loads
- Out-of-square backing shoulders on shafts or housings

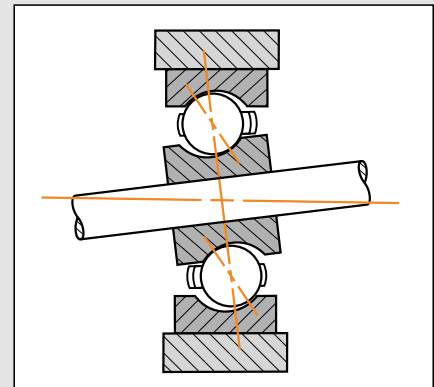

Fig. 34A. Shaft misalignment

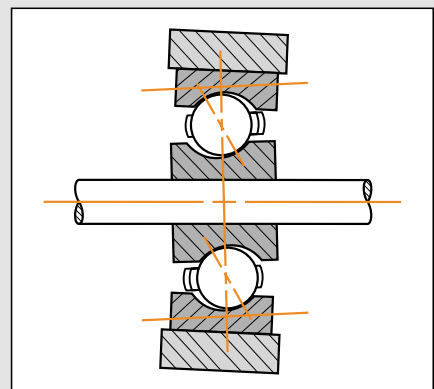

Fig. 34B. Housing misalignment



Fig. 35. Deflection, inaccurate machining or wear of bearing seats caused an irregular roller path on this tapered roller bearing outer ring.



Fig. 36. This irregular roller path is 180 degrees opposite of Fig. 35.

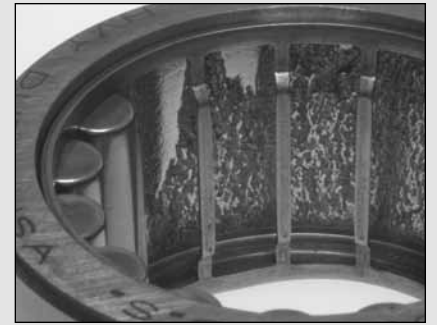

Fig. 37. The housing bore was machined with an improper taper, causing the uneven load distribution and GSC spalling in this cylindrical roller bearing outer ring.

Handling and Installation Damage

Care must be taken in handling and assembling bearings so the rolling elements and race surfaces and edges are not damaged. Deep gouges in the race surface or battered and distorted rolling elements will cause metal to be raised around the gouge or damaged area. High stresses will occur as the rolling elements go over these surfaces, resulting in premature, localized spalling. The immediate effect of the gouges and deep nicks will be roughness, vibration and noise in the bearing.

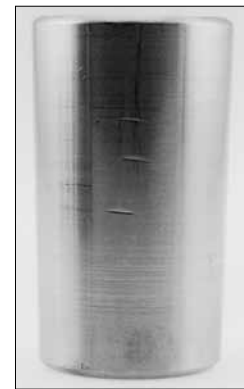

Fig. 38 Rough handling or installation damage resulted in nicks and dents in this tapered bearing roller.



Fig. 39. This spherical roller bearing inner race depicts a fractured small rib caused by the use of improper installation tools.

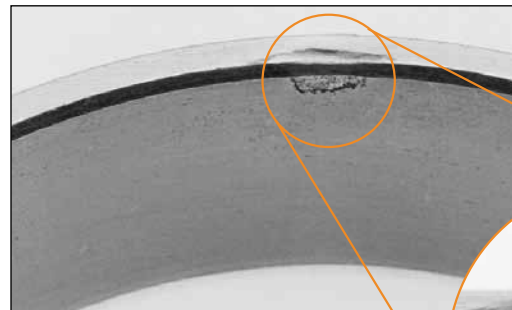
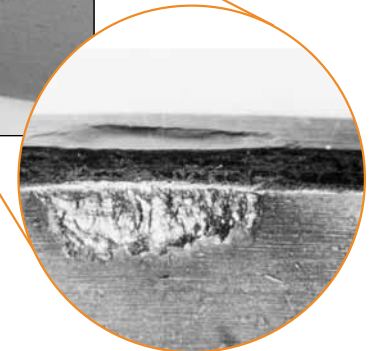

Fig. 40. A hardened driver caused cup face denting on this tapered roller bearing.



Fig. 41. Tapered roller spaced nicking was caused by the roller edges hitting the race during installation. These nicks/dents have raised edges that can lead to excessive noise, vibration or act as points of stress concentration.



Damaged Bearing Cages or Retainers

Careless handling and the use of improper tools during bearing installation may cause cage or retainer damage. Cages or retainers are usually made of mild steel, bronze or brass and can be easily damaged by improper handling or installation, resulting in premature bearing performance problems.

In some applications, fractured cages or retainers may be caused by environmental and operating conditions. This type of damage is too complex to cover in this reference guide. If you experience this problem, contact your Timken sales or service engineer.

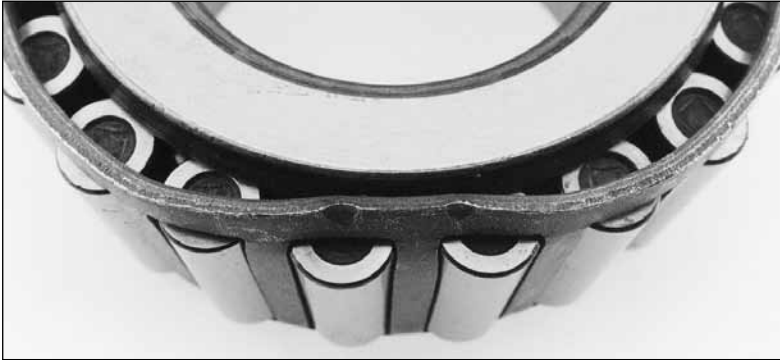

Fig. 42. *This cage deformation was caused by an improperly installed or dropped bearing.*



Fig. 43. *Binding and skewing of these tapered rollers was due to the compression of the cage ring during installation or interference during service.*



Fig. 44. *Poor handling practices caused a deep dent on this spherical roller bearing cage bridge. This damage will result in a lack of proper roller rotation, possible roller skidding, increased temperatures and decreased life.*

High Spots and Fitting Practices

Careless handling or damage when driving outer races out of housings or wheel hubs can result in burrs or high spots in the outer race seats. If a tool gouges the housing seat surface, it will leave raised areas around the gouge. If these high spots are not scraped or ground down before the outer race is reinstalled, the high spot will transfer through the outer race and cause a corresponding high spot in the outer race inside diameter. As the rolling elements hit this high area, stresses are increased, resulting in lower than predicted service life.



Fig. 45. A worn-out housing caused this bearing to lose fit and fret (move) during service. As a result, metal tearing and wear on this spherical outer ring occurred.

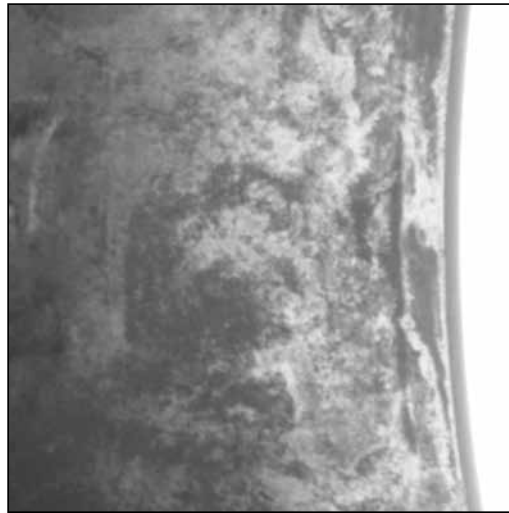

Fig. 46. Classic fretting corrosion from poor fitting practice is depicted here. Relative movement under load between the bearing and its seat caused this worn and corroded condition.



Fig. 47. The marks on the outside diameter of this cup are caused by a high spot on the housing. The cup race is spalled at the spot that corresponds to the spot on the outside of the cup marked from heavy contact.

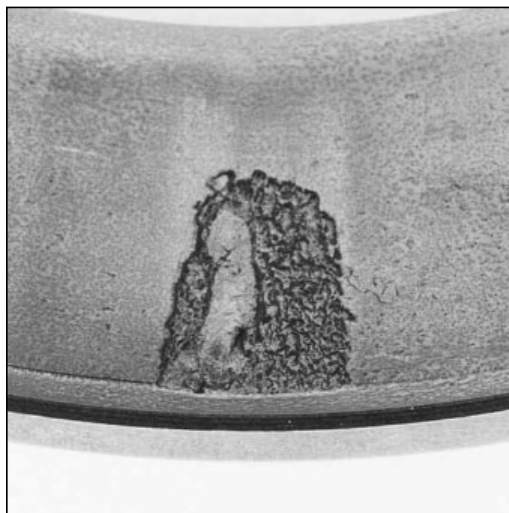

Fig. 48. Localized spalling on this cup race was the result of a stress riser created by a split housing pinch point.

Improper Fit in Housings or Shafts

A manufacturer's recommended bearing fit should be followed to ensure proper bearing performance.

In general, the bearing race where the rotating load exists should be applied with a press or tight fit. An example is a wheel hub where the outer race should be applied with a press fit. The races on a stationary axle would normally be applied with a light or loose fit. Where the shaft rotates, the inner race should normally be applied with a press fit and the outer race may be applied with a split fit or even a loose fit, depending on the application.



Fig. 49. A loose cup fit in a rotating wheel hub (typically tight) caused this bearing race damage.



Fig. 50. This is what happens to a cup that is loose in a wheel hub. The cup turns and wears the cup seat so the fit becomes more loose. Then the cup starts to stretch or roll out. The cup, as it rolls out, continues to wear the cup seat and the cup continues to stretch. This process continues to the point where the stretch of the metal reaches the breaking point and the cup cracks open, as it has in this case.



Fig. 51. This ball bearing inner ring fracture is a result of being installed on top of a metal contaminant or raised metal nick.



Fig. 52. An out-of-round or oversized shaft caused this fracture on a tapered roller bearing cone.

Brinell and Impact Damage

Improper mounting practices and/or extremely high operational impact or static loads may cause brinelling.

Brinell due to improper mounting is caused where a force is applied against the unmounted race. When mounting a bearing on a shaft with a tight fit, pushing the outer race will exert an excessive thrust load and bring the rolling elements into sharp contact with the race, causing brinell.

Fig. 54A shows improper removal of a bearing off a shaft, while 54B illustrates the proper mounting procedure.

Extremely heavy impact loads, which may be short in duration, can result in brinell of the bearing races and sometime even fracture the races and rolling elements.

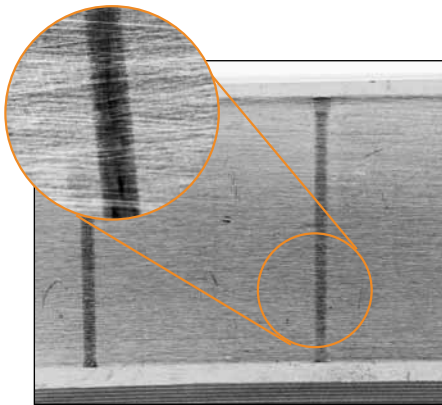

Fig. 53. A heavy impact load on this tapered bearing cup race caused brinell and impact damage. These same indentations are evident on the cone race. This is true metal deformation and not wear as with false brinelling. The close-up view of one of the grooves shows the grinding marks still in the groove.

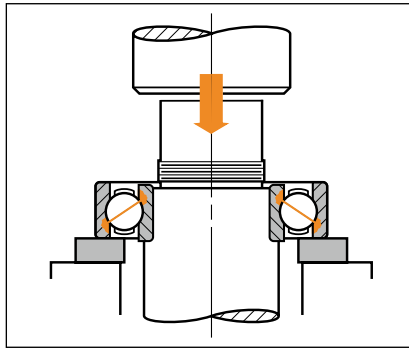

Fig. 54A. Incorrect dismounting of bearing on arbor press.

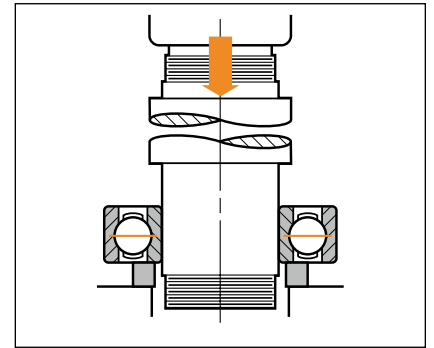

Fig. 54B. Proper mounting procedure on arbor press.

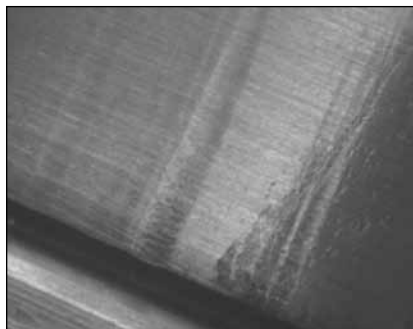

Fig. 55. This inner ring of a spherical roller bearing shows roller impact damage from shock loading.



Fig. 56. Shock loading caused brinell damage on this ball bearing inner ring.

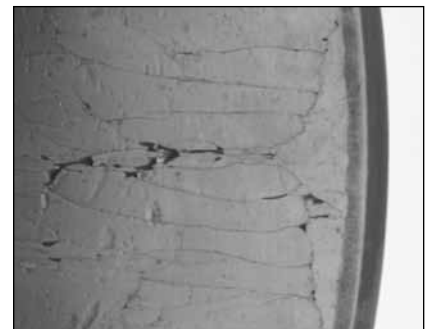

Fig. 57. This cylindrical roller bearing inner ring is crushed by an application failure during service.

False Brinelling

False brinelling is, as the name implies, not true brinelling or denting. False brinelling is actually fretting wear. It is caused by slight axial movement of the rolling elements while the bearing is stationary. A groove is worn into the race by the sliding of the rolling element back and forth across the race. Vibration causes the sliding movement.

There are times when this cannot be prevented, such as when automobiles or other types of equipment are shipped by rail or truck for relatively long distances. It also can occur during shipment by ocean freight. The vibration present may cause enough movement to produce some of this false brinelling. It can be greatly reduced or eliminated by reducing the potential for relative movement and decreasing the static weight present during shipment or storage.

Rolling element bearings also exhibit false brinelling when used in positions that encounter very small reversing angular oscillation (less than one complete rotation of the rolling element).

False brinelling can be distinguished from true brinelling by examining the depression or wear area. False brinelling will actually wear away the surface texture whereas the original surface texture will remain in the depression of a true brinell.

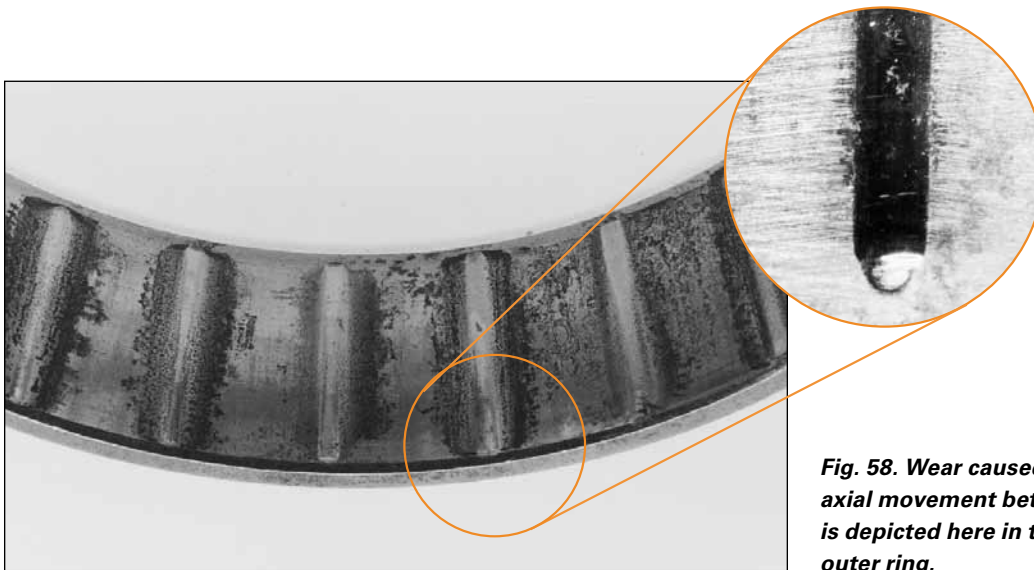

Fig. 58. Wear caused by vibration or relative axial movement between the rollers and races is depicted here in this tapered roller bearing outer ring.

Burns from Electric Current

Arcing, which produces high temperatures at localized points, results when an electric current that passes through a bearing is broken at the contact surfaces between the races and rolling elements. Each time the current is broken while passing between the ball or roller and race, a pit is produced on both parts. Eventually fluting develops. As it becomes deeper, noise and vibration result. A high-amperage current, such as a partial short circuit, will cause a rough, granular appearance. Heavy jolts of high-amperage charges will cause more severe damage, resulting in the welding of metal from the race to the ball or roller. These protrusions of metal on the roller will, in turn, cause a crater effect in the race, resulting in bearing noise and vibration.

Causes of arcing include static electricity from charged belts or processes that use calendar rolls, faulty wiring, improper grounding, welding, inadequate or defective insulation, loose rotor windings on an electric motor and short circuits.

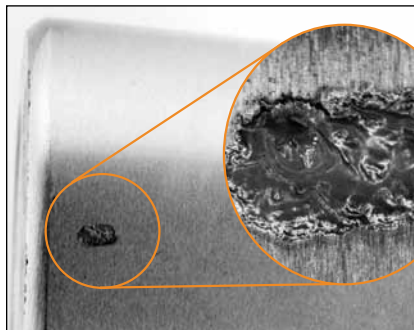

Fig. 59. Electric arc pitting or small burns, magnified 10X here, were created by arcs from improper electric grounding while the bearing was stationary.



Fig. 60. Welding on a machine, while the bearings were rotating, caused electric arc fluting on this spherical roller bearing.

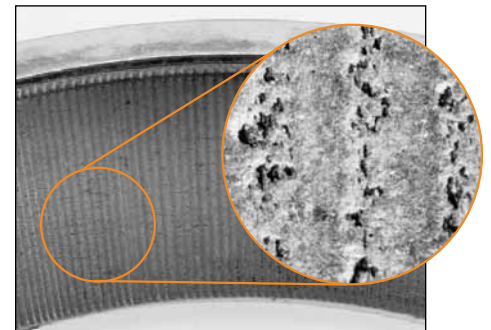

Fig. 61. Magnified 10X, this fluting, defined as a series of small axial burns, was caused by an electric current passing through the bearing while it was rotating.

Cam Fracture

Cam Fracture: Wide Inner Ring Ball Bearings

An undersized shaft or an outer ring that cannot be aligned due to the housing may cause a broken cam, a misaligned travel path or bearing wobble.

This type of bearing damage may be prevented by using the correct size shaft and by using the Timken self-aligning feature, a spherical outer ring to compensate for initial misalignment and correctly mount bearings.

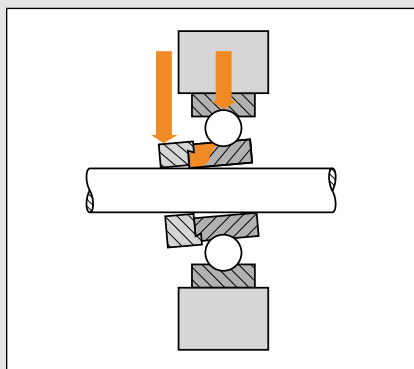

Fig. 62A. Shaft below suggested tolerance levels.

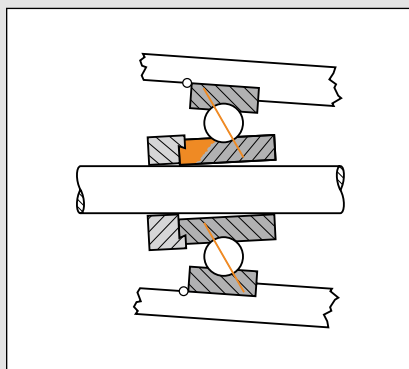

Fig. 62B. Misaligned outer ring.

Understanding Bearing Life

Bearing Service Life

Bearing service life is dependent on many factors. Depending on the application requirements, the actual service life can vary greatly. For example, a machine tool spindle bearing may be unfit for further service due to minor wear that affects spindle accuracy. In contrast, a rolling mill roll neck bearing may provide satisfactory service life even if the bearing has developed spalling damage, provided the spalls are properly repaired in a timely fashion.

Reduced service life can be caused either individually or by any combination of:

- Faulty mounting
- Improper adjustment
- Insufficient lubrication
- Contamination
- Improper or abusive handling
- Poor housing support
- High-static misalignment or shaft and housing deflection
- Poor or inconsistent maintenance practices

The life of your bearing is dependent on the load zone obtained under operating conditions. Generally speaking, the greater the load zone, the longer the life of the bearing under stabilized operating conditions. Fig. 63 illustrates this relationship for tapered roller bearings; other roller bearings with radial loads would have a similar performance relationship.

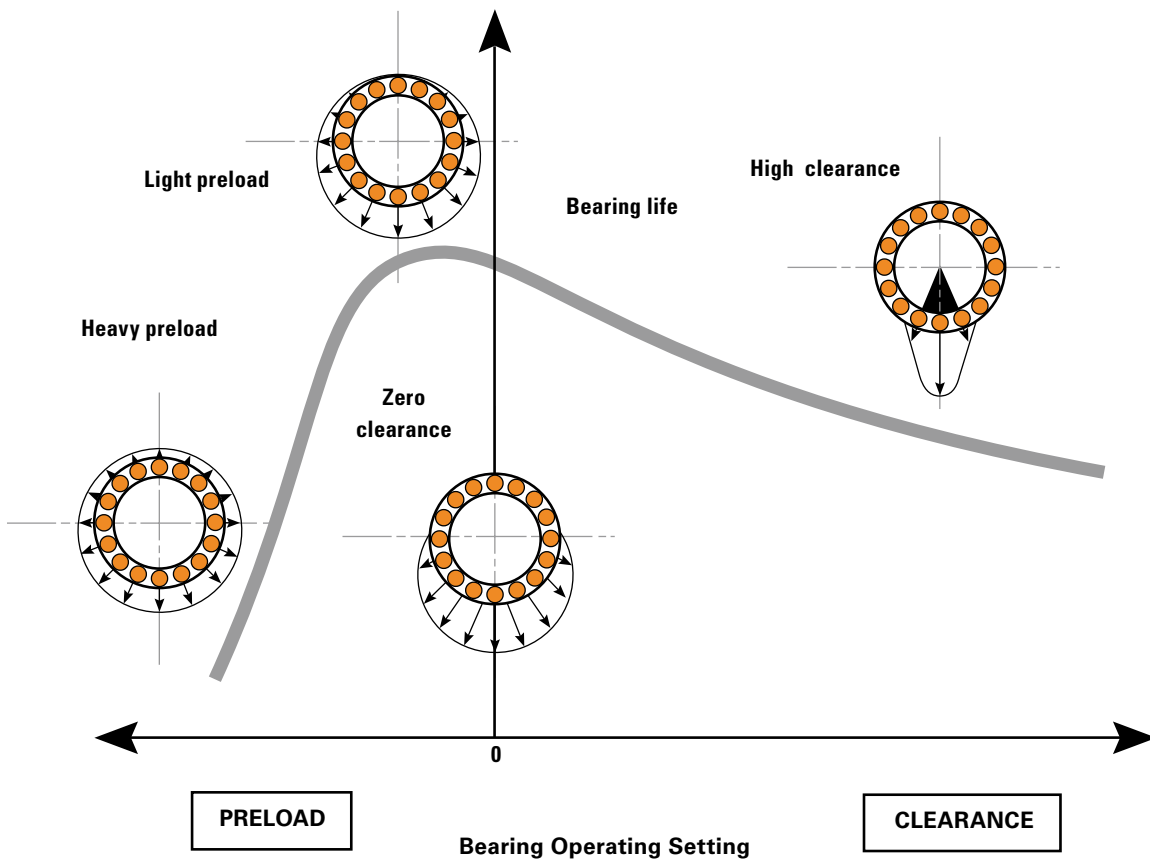

Fig. 63. Bearing life vs. bearing operating setting.

Lubrication Reference Guide

Factors that Impact Lubrication Performance

As noted on page 10, the life of a Timken® bearing depends to a great extent on the proper lubrication of the bearing. Grease lubricants aid in protecting bearing surfaces from corrosion and reducing friction.

A very high percentage of all bearing damage can be attributed to inadequate lubrication. Although a very broad term, inadequate lubrication can be classified into eight basic categories:

- Overfilling
- Underfilling
- Incorrect grease
- Mixing greases
- Incorrect lubrication systems and intervals
- Worn-out grease
- Water contamination
- Debris contamination

Overfilling

Overfilling a bearing with too much grease can cause excess churning during operation and high temperatures, resulting in overheating and excess grease purging (leaking) – see note below. Overheating occurs because the heat generated cannot dissipate correctly, continually building until damage occurs. As the operating temperature of the bearing rises, the oxidation (breakdown) rate of the grease sharply increases – doubling every 10° C (18° F).



Fig. 65. 'Clean' grease slightly purging (leaking) from a bearing during initial start-up is generally acceptable. The grease is wet and evenly purged. If this slight purge is not causing any problems, leave it alone as it is an effective barrier seal.



Fig. 64. This petri dish above contains heavily oxidized grease, which purged from an overfilled bearing. Grease undergoing heavy oxidation often has a very distinguishable black color and burned odor. In addition, it gets stiffer in consistency.

NOTE

During initial start-up, it is common for a properly greased bearing to purge a small amount of grease. A slight grease purge is often recommended by original equipment manufacturers, as it acts as a barrier seal to help keep out external debris contamination (Fig. 65). Always follow original equipment manufacturers' recommendations regarding grease purging and correct replenishment amounts.

An overfilled bearing may also purge grease during initial start-up. However, over time and as temperature rises, excess grease will continue to purge from an overfilled bearing and have a darkened color (Fig. 64).

Underfilling

Underfilling a bearing with grease also can have adverse consequences. As in overfilling, heat can be generated but for different reasons. When the grease amount is low, a grease starvation condition may be created, causing heat generation or excessive metal wear during operation. If a bearing suddenly becomes noisy and/or the temperature increases, excessive wear may be taking place.

Fig. 66. Grease removed from an underfilled bearing shows shiny bearing metal debris.



Incorrect Grease

The base oil in a particular grease may have a different thickness (viscosity) than what is recommended for your application. If the base oil viscosity is too heavy, the rolling elements may have difficulty in pushing through the grease and begin to skid (Fig. 67). If this occurs, excessive grease oxidation (breakdown) (Fig. 68A) may cause premature grease degeneration and excessive wear of bearing components. If the viscosity is too light, peeling (micro-spalling) and wear (Fig. 68B) may result due to thin lubricant film from elevated temperatures. In addition, the additives contained in a particular grease may be inappropriate or even incompatible with surrounding components in your system.



Fig. 67. This cylindrical roller flattened as a result of skidding



Fig. 68A.



Fig. 68B.

Micro-spalling in a tapered roller bearing outer race (Fig. 68A) and inner race (Fig. 68B) was due to thin lubricant film.

Mixing Greases

A bearing may be running well with the correct grease. However, while performing routine maintenance, a technician may decide to lubricate the bearing with a different type of grease. If the greases are not compatible, or are an incorrect consistency, the grease mixture will do one of two things:

1. Soften and leak out of the bearing due to grease thickener incompatibility.
2. Become lumpy, discolored and hard in composition (Fig. 69).



Fig. 69. Grease A and Grease B are not compatible. When mixed together they become lumpy, discolored and hard in composition (Grease C).

Worn-Out Grease

Grease is a precise combination of additives, oil and thickener (Fig. 70). Grease acts like a sponge to retain and release the oil. As a result of time and temperature conditions, the oil release properties can become depleted. When this occurs, the grease is worn-out (Fig. 71).



Fig. 70. Grease is a precise combination of additives, oil and thickener.

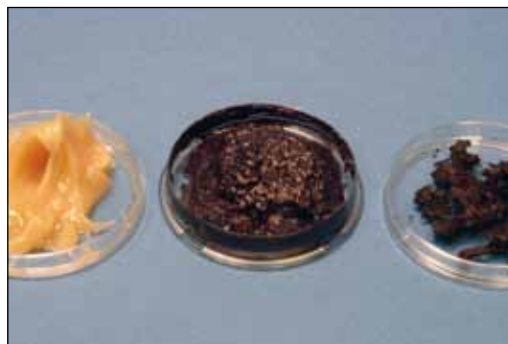

Fig. 71. The above photo shows the same grease at three stages from left to right. 1) new grease, 2) heavily oxidized grease, and 3) worn-out (failed) grease where the thickener and additives have decomposed and the oil has broken down.

Incorrect Lubrication Systems and Intervals

Maintaining correct bearing lubrication systems and intervals is critical to help prevent premature wear of bearing components.

If maintenance schedules are not followed (Fig. 72), lubrication may deteriorate through excessive oxidation.

Fig. 72. A technician records key bearing lubrication data on a maintenance sheet.



Water Contamination

Fig. 73 shows the effect of water on grease by comparing fresh grease to a grease emulsified with 30 percent water. The fresh grease is smooth and buttery compared to the water laden grease, which is milky white in appearance. As little as one percent water in grease can have a significant impact on bearing life.

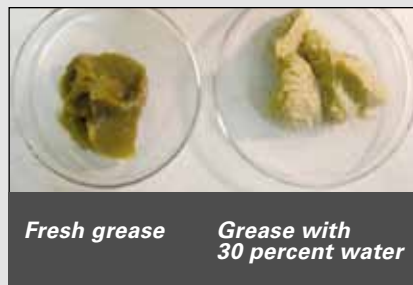

Fig. 73. The effect of water on grease is depicted here.



Fig. 74.

A tapered roller bearing cone and rollers and a ball bearing outer race and balls (Fig. 75) show rusting with pitting and corrosion from moisture/water exposure.



Fig. 75.

⚠ WARNING Failure to observe the following warnings could create a risk of serious injury.

Heated grease or water may create a risk of burns or eye damage. Wear suitable personal protective clothing, including eye protection and gloves, when performing this test.

Quick and Easy Field Test to Determine Water in Grease

An easy, non-quantified method of determining the presence of water in grease is known as the crackle test. To perform this test, place a sample of grease on a piece of aluminum foil (Fig. 76) and put a flame under the foil (Fig. 77). If the grease melts and lightly smokes, the presence of water is minimal. However, if the grease crackles, sizzles and/or pops, the grease contains a considerable amount of water.



Fig. 76. To perform a crackle test, first put the grease sample on a piece of aluminum foil.



Fig. 77. A crackle test determines the presence of water in grease.

Lubrication Guidelines

Required Grease Quantity

To avoid the generation of heat, the bearing must not be over greased. The required quantity of grease is based on the free volume of the bearing calculated as follows:

$$V \approx \pi/4 (D^2 - d^2) (T) - M/A$$

Where:

V = free volume in the bearing (mm³ – in.³)

D = outer race O.D. (mm – in.)

d = inner race bore (mm – in.)

T = overall width (mm – in.)

M = bearing weight (kg – lb)

A = average steel density 7.8 x 10⁻⁶ kg / mm³ 0.283 lb / in.³

π = 3.1416

Grease should be packed into the bearing so that it gets between the rolling elements – the rollers or balls. For tapered roller bearings, forcing grease through the bearing from the large end to the small end will ensure proper distribution. Special recommendations apply to sealed bearing assemblies. Contact a Timken sales or service engineer for more information.

Consult the original equipment manufacturer for all lubricant information.

Grease Compatibility Chart

| <ul style="list-style-type: none"> = Best Choice = Compatible = Borderline = Incompatible | Al Complex | Ba Complex | Ca Stearate | Ca 12 Hydroxy | Ca Complex | Ca Sulfonate | Clay Non-Soap | Li Stearate | Li 12 Hydroxy | Li Complex | Polyurea | Polyurea S S |
|---|--------------|--------------|--------------|---------------|--------------|--------------|---------------|--------------|---------------|--------------|--------------|--------------|
| Aluminum Complex | Best Choice | Incompatible | Incompatible | Compatible | Incompatible | Incompatible | Incompatible | Incompatible | Incompatible | Compatible | Incompatible | Incompatible |
| Timken Food Safe | Best Choice | Incompatible | Incompatible | Compatible | Incompatible | Borderline | Incompatible | Incompatible | Incompatible | Compatible | Incompatible | Incompatible |
| Barium Complex | Incompatible | Best Choice | Compatible | Compatible | Incompatible | Incompatible | Incompatible | Incompatible | Incompatible | Incompatible | Incompatible | Borderline |
| Calcium Stearate | Incompatible | Incompatible | Best Choice | Compatible | Incompatible | Incompatible | Incompatible | Compatible | Borderline | Compatible | Incompatible | Compatible |
| Calcium 12 Hydroxy | Compatible | Compatible | Compatible | Best Choice | Borderline | Incompatible | Compatible | Compatible | Compatible | Compatible | Incompatible | Compatible |
| Calcium Complex | Incompatible | Incompatible | Incompatible | Incompatible | Best Choice | Incompatible | Incompatible | Incompatible | Incompatible | Incompatible | Compatible | Compatible |
| Calcium Sulfonate | Borderline | Compatible | Compatible | Borderline | Incompatible | Best Choice | Incompatible | Borderline | Borderline | Compatible | Incompatible | Compatible |
| Timken Premium Mill Timken Heavy Duty Moly | Borderline | Compatible | Compatible | Borderline | Incompatible | Best Choice | Incompatible | Borderline | Borderline | Compatible | Incompatible | Compatible |
| Clay Non-Soap | Incompatible | Incompatible | Compatible | Compatible | Incompatible | Incompatible | Best Choice | Incompatible | Incompatible | Incompatible | Incompatible | Borderline |
| Lithium Stearate | Incompatible | Incompatible | Compatible | Compatible | Incompatible | Borderline | Incompatible | Best Choice | Compatible | Compatible | Incompatible | Compatible |
| Lithium 12 Hydroxy | Incompatible | Incompatible | Borderline | Compatible | Incompatible | Borderline | Incompatible | Compatible | Best Choice | Compatible | Incompatible | Compatible |
| Lithium Complex | Compatible | Incompatible | Compatible | Compatible | Compatible | Compatible | Incompatible | Compatible | Compatible | Best Choice | Incompatible | Compatible |
| Polyurea Conventional | Incompatible | Incompatible | Incompatible | Incompatible | Compatible | Incompatible | Incompatible | Incompatible | Incompatible | Incompatible | Best Choice | Compatible |
| Polyurea Shear Stable | Compatible | Borderline | Compatible | Compatible | Compatible | Compatible | Borderline | Compatible | Compatible | Compatible | Compatible | Best Choice |
| Timken Multi-Use Synthetic | Incompatible | Incompatible | Borderline | Compatible | Incompatible | Borderline | Incompatible | Compatible | Best Choice | Compatible | Incompatible | Compatible |
| Timken All Purpose Timken Premium Synthetic | Compatible | Incompatible | Compatible | Compatible | Compatible | Compatible | Incompatible | Compatible | Compatible | Best Choice | Incompatible | Compatible |
| Timken High Speed | Incompatible | Incompatible | Incompatible | Incompatible | Compatible | Compatible | Incompatible | Incompatible | Incompatible | Incompatible | Best Choice | Compatible |
| Timken Pillow Block | Compatible | Borderline | Compatible | Compatible | Compatible | Compatible | Borderline | Compatible | Compatible | Compatible | Compatible | Best Choice |

Glossary

Abrasive Wear

Usually occurs when foreign particles cut the bearing surfaces.

Adhesive Wear

Caused by metal-to-metal contact, resulting in scuffing or scoring of the bearing surfaces.

Angular Contact Ball Bearing

Ball bearing whose internal clearance and race location result in predetermined angle of contact.

Axial Endplay

The total relative measurable axial displacement of the shaft to the housing in a system of two angular contact bearings, such as angular contact ball bearings or tapered roller bearings.

Axial Internal Clearance

In radial bearing types, total maximum permissible axial displacement (parallel to bearing axis) of inner ring relative to outer ring.

Axial Load

Load acting in direction parallel with bearing axis. Also known as thrust.

Brinelling

A dent or depression in the bearing raceway due to extremely high-impact or static loads.

Brinelling – False

Wear grooves in the raceway caused by minute movement or vibration of the rolling elements while the bearing is stationary.

Bruising

The denting or plastic indentation in the raceways and rolling elements due to the contamination of foreign particles in the bearing.

Etching – Corrosion

Usually caused by moisture or water contamination and can vary from light staining to deep pitting.

Fatigue

The fracture and breaking away of metal in the form of a spall. Generally, there are three modes of contact fatigue recognized:

- Inclusion origin
- Geometric stress concentration
- Point surface origin

Fillet Radius

Shaft or housing corner dimension that bearing corner must clear.

Fixed Bearing

Bearing which positions shaft against axial movement in both directions.

Floating Bearing

Bearing so designed or mounted as to permit axial displacement between shaft and housing.

Fluting

Electro-etching on both the inner and outer ring.

Fretting Corrosion

Usually occurs on the bores, outside diameters and faces of bearing races due to minute movement of these surfaces and the shaft or housing. Red or black oxide of iron is usually evident.

Housing Fit

Amount of interference or clearance between bearing outside surface and housing bearing seat.

Life

The theoretical bearing life expectancy of a group of bearings can be calculated from the operating conditions and the bearing load rating based on material fatigue.

These calculations must assume that the bearings are correctly mounted, adjusted, lubricated and otherwise properly handled.

Misalignment

A bearing mounted condition whereby the centerline of the inner race is not aligned with the centerline of the outer race.

Lack of parallelism between axis of rotating member and stationary member are some of the causes of misalignment, as are machining errors of the housing/ shaft, deflection due to high loads, and excessive operating clearances.

Preload

The absence of endplay or internal clearance. All of the rolling elements are in contact or in compression with the inner and outer races or cups and cones. Internal load on the rolling elements of bearing, which is the result of mounting conditions or design. Can be intentional or unintentional.

Radial Internal Clearance

In radial bearing types, the total maximum possible radial displacement (perpendicular to bearing axis) of inner ring, relative to outer ring.

Radial Load

Load acting in direction perpendicular with bearing axis.

Scoring

Caused by metal-to-metal contact, resulting in the removal and transfer of metal from one component of a bearing to another. Various degrees of scoring can be described as scuffing, smearing, sliding, galling or any other sliding motion.

Shaft Fit

Amount of interference or clearance between bearing inside diameter and shaft bearing seat outside diameter.

Spalling – Flaking

A breaking away of metal on the raceway or rolling elements in flake or scale-like particles.

Types of Bearings and Nomenclature

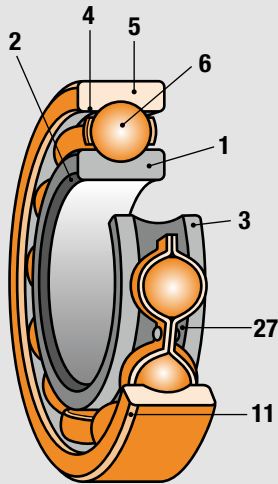

Single Row Deep Groove Ball Bearing

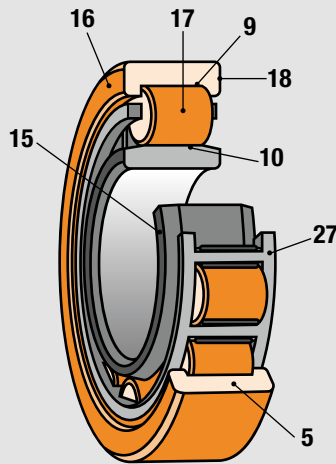

Cylindrical Roller Bearing

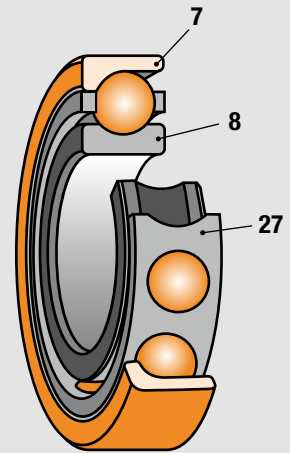

Angular Contact Ball Bearing

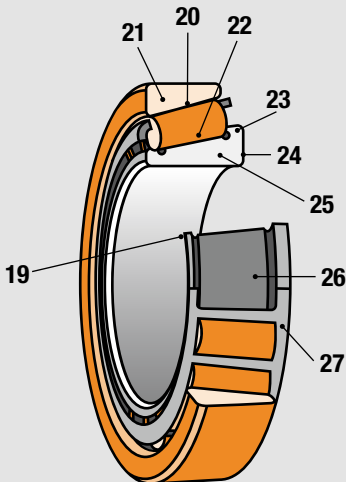

Tapered Roller Bearing

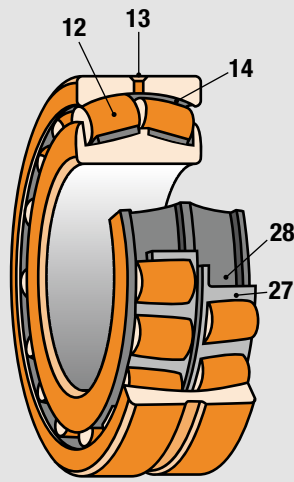

Spherical Roller Bearing

Bearing Nomenclature Key

- | | | | |
|-----------------------------|--|------------------------|-------------------------------|
| 1. Inner Ring | 9. Outer Ring Race | 15. Inner Ring Face | 24. Cone Back Face |
| 2. Inner Ring Corner Radius | 10. Inner Ring Race | 16. Outer Ring Face | 25. Cone (Inner Ring) |
| 3. Inner Ring Land | 11. Outer Ring Corner Radius | 17. Cylindrical Roller | 26. Cone Race |
| 4. Outer Ring Land | 12. Spherical Roller | 18. Outer Ring Face | 27. Cage |
| 5. Outer Ring | 13. Lubrication Feature (Holes and Groove) | 19. Cone Front Face | 28. Spherical Inner Ring Race |
| 6. Ball | 14. Spherical Outer Ring Race | 20. Cup Race | |
| 7. Counter Bore | | 21. Cup (Outer Ring) | |
| 8. Thrust Face | | 22. Tapered Roller | |
| | | 23. Cone Large Rib | |

Tapered Roller Bearing Speed Capability Guidelines

Speed Capability Guidelines

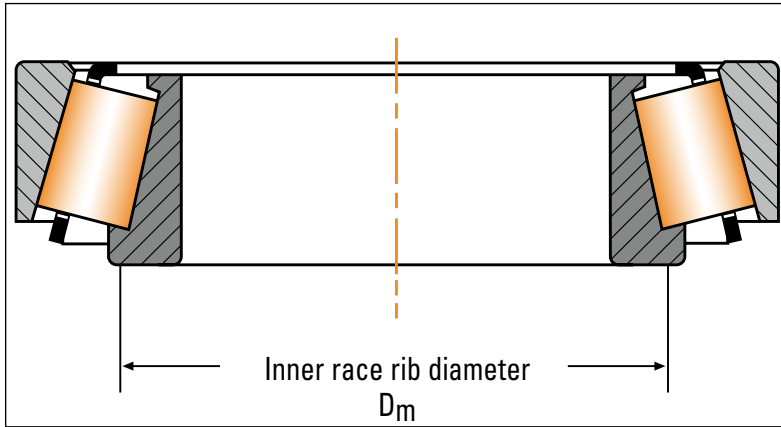

Rib speed:
 $V_r = \pi D_m n / 60000$ (m/s)
 $V_r = \pi D_m n / 12$ (ft/min)

Where:
 D_m = Inner race rib diameter (mm, in.)
 n = Bearing speed (rev/min)
 π = 3.1416

Fig. 78. The inner race rib diameter can be scaled from a drawing or can be approximated as the average of the bearing inner and outer diameter.

Speed Capability Guidelines for Various Types of Lubrication Systems

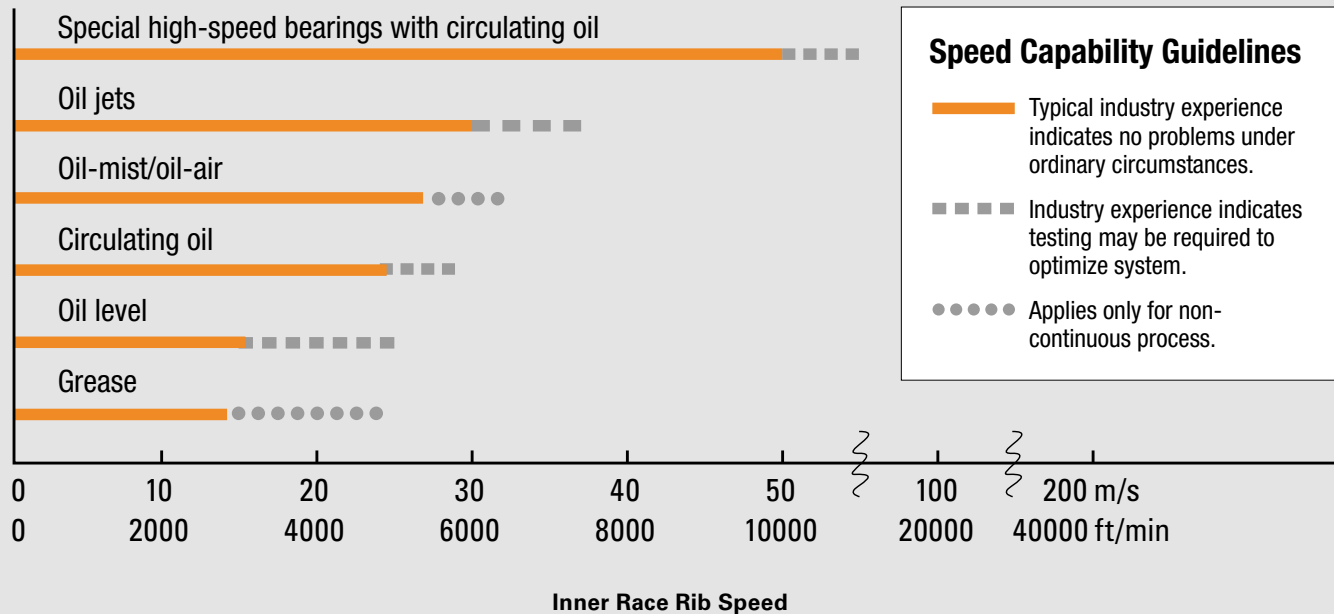

Fig. 79. Here is a summary of guidelines relating to speed and temperature for tapered roller bearings. There are no clear-cut speed limitations for bearings regardless of the bearing design or lubrication systems. The Timken Company recommends that testing be performed for all new high-speed applications, regardless of bearing design.

Temperature Guidelines for Roller Bearing Installation

Temperature Guidelines

Maximum and minimum temperatures, as well as maximum time-at-temperature limits, have been established to prevent metallurgical transformation of steel components and potential, detrimental physical changes in seals or non-metallic components. During the manufacturing process, bearing rings and rolling elements are heat treated to define the strength, hardness and dimensional stability for proper operation. Heating or cooling bearings or bearing components beyond these limits may affect performance.

These suggestions are merely guidelines and, as new data is developed, the values as shown may change. These guidelines do not cover all Timken® products.

Heating

- These are the maximum temperature limits.
- For elastomer or polymer seals or cages, only use hot air as a heating medium.
- Protect exposed bearing/ring surfaces after positioning on the shaft or housing, and as they normalize to ambient temperatures.

Standard Class Bearings or Rings (with metallic cages and without seals)

Includes Class 4, 2, K, N, ABEC-1 and ABEC-3.
121° C (250° F)..... 0.8 Hours

Standard Class Bearings or Rings (with non-metallic cages and polymer or elastomer seals)

Special considerations may apply for phenolic cages or special fluorocarbon lip seals.
93° C (200° F) 24 Hours

Precision and Super Precision Class Bearings and Rings

Include Class 3, 0, 00, 000, C, B, A, ABEC 5, 7, 9.
66° C (150° F) 24 Hours

Cooling (Freezing)

- These are the minimum temperature limits.
- To prevent corrosion:
 - Before installation, remove frost from all surfaces.
 - After installation and during part warming, remove moisture condensation.
 - Wipe surfaces with clean, lint-free cloth and reapply preservative.

Freezing Standard Class Bearings and Rings

-54° C (-65° F) 1 Hour
This temperature can be obtained using dry ice in an alcohol bath.

Freezing Precision Class Outer Rings or Cups

-29° C (-20° F) 2 Hours
This temperature can be obtained by commercial freezer/refrigeration equipment.

⚠ WARNING *Failure to observe the following warnings could create a risk of serious injury.*

Proper maintenance and handling procedures are critical. Always follow installation and maintain proper lubrication.

Cone Bore Growth Expansion Rates Due to Thermal Changes

Thermal growth of components can be calculated using the formula: $d \times \Delta T \times \alpha = \text{Thermal Growth}$

Where:

d = bearing bore diameter

ΔT = maximum bearing temperature after heating minus ambient temperature

α = coefficient of linear expansion: $11 \times 10^{-6} / ^\circ\text{C}$ ($6.1 \times 10^{-6} / ^\circ\text{F}$) for ferrous metal shaft and housing materials

| Cone Bore | Thermometer temperature reading in degrees | | | Cone Bore | Thermometer temperature reading in degrees | | |
|-------------|--|-----------------|------------------|-------------|--|-----------------|------------------|
| | 65° C 150° F | 90° C 200° F | 120° C 250° F | | 65° C 150° F | 90° C 200° F | 120° C 250° F |
| mm in. | mm in. | mm in. | mm in. | mm in. | mm in. | mm in. | mm in. |
| 25.4 1 | 0.012 0.0005 | 0.020 0.0008 | 0.027 0.0011 | 482.6 19 | 0.231 0.0091 | 0.375 0.0148 | 0.520 0.0205 |
| 50.8 2 | 0.025 0.0010 | 0.040 0.0016 | 0.055 0.0022 | 508 20 | 0.243 0.0096 | 0.396 0.0156 | 0.548 0.0216 |
| 76.2 3 | 0.036 0.0014 | 0.058 0.0023 | 0.081 0.0032 | 533.4 21 | 0.256 0.0101 | 0.416 0.0164 | 0.576 0.0227 |
| 101.6 4 | 0.048 0.0019 | 0.078 0.0031 | 0.109 0.0043 | 558.8 22 | 0.269 0.0106 | 0.436 0.0172 | 0.604 0.0238 |
| 127 5 | 0.061 0.0024 | 0.099 0.0039 | 0.137 0.0054 | 584.2 23 | 0.279 0.0110 | 0.454 0.0179 | 0.629 0.0248 |
| 152.4 6 | 0.073 0.0029 | 0.119 0.0047 | 0.165 0.0065 | 609.6 24 | 0.292 0.0115 | 0.475 0.0187 | 0.657 0.0259 |
| 177.8 7 | 0.086 0.0034 | 0.139 0.0055 | 0.193 0.0076 | 635 25 | 0.304 0.0120 | 0.495 0.0195 | 0.685 0.0270 |
| 203.2 8 | 0.096 0.0038 | 0.157 0.0062 | 0.218 0.0086 | 660.4 26 | 0.317 0.0125 | 0.515 0.0203 | 0.713 0.0281 |
| 228.6 9 | 0.109 0.0043 | 0.177 0.0070 | 0.246 0.0097 | 685.8 27 | 0.330 0.0130 | 0.535 0.0211 | 0.741 0.0292 |
| 254 10 | 0.121 0.0048 | 0.198 0.0078 | 0.274 0.0108 | 711.2 28 | 0.340 0.0134 | 0.553 0.0218 | 0.767 0.0302 |
| 279.4 11 | 0.134 0.0053 | 0.218 0.0086 | 0.302 0.0119 | 736.6 29 | 0.353 0.0139 | 0.574 0.0226 | 0.795 0.0313 |
| 304.8 12 | 0.147 0.0058 | 0.238 0.0094 | 0.330 0.0130 | 762 30 | 0.365 0.0144 | 0.594 0.0234 | 0.823 0.0324 |
| 330 13 | 0.157 0.0062 | 0.256 0.0101 | 0.355 0.0140 | 787.4 31 | 0.378 0.0149 | 0.614 0.0242 | 0.850 0.0335 |
| 355.6 14 | 0.170 0.0067 | 0.276 0.0109 | 0.383 0.0151 | 812.8 32 | 0.391 0.0154 | 0.635 0.0250 | 0.878 0.0346 |
| 381 15 | 0.182 0.0072 | 0.297 0.0117 | 0.411 0.0162 | 838.2 33 | 0.401 0.0158 | 0.652 0.0257 | 0.904 0.0356 |
| 406.4 16 | 0.195 0.0077 | 0.317 0.0125 | 0.439 0.0173 | 863.6 34 | 0.414 0.0163 | 0.673 0.0265 | 0.932 0.0367 |
| 431.8 17 | 0.208 0.0082 | 0.337 0.0133 | 0.467 0.0184 | 889 35 | 0.426 0.0168 | 0.693 0.0273 | 0.960 0.0378 |
| 457.2 18 | 0.218 0.0086 | 0.355 0.0140 | 0.492 0.0194 | 914.4 36 | 0.439 0.0173 | 0.713 0.0281 | 0.988 0.0389 |

Calculations are based on an ambient temperature of 21° C (70° F).

Conversion Equivalents for U.S. and Metric Measurements

VISCOSITY CONVERSION TABLE

| SUS Saybolt (sec.) | R" Redwood (sec.) | E Engler (deg.) | cSt Centistokes (mm ² /s) |
|--------------------|-------------------|-----------------|--------------------------------------|
| 35 | 32.2 | 1.18 | 2.7 |
| 40 | 36.2 | 1.32 | 4.3 |
| 45 | 40.6 | 1.46 | 5.9 |
| 50 | 44.9 | 1.60 | 7.4 |
| 55 | 49.1 | 1.75 | 8.9 |
| 60 | 53.5 | 1.88 | 10.4 |
| 65 | 57.9 | 2.02 | 11.8 |
| 70 | 62.3 | 2.15 | 13.1 |
| 75 | 67.6 | 2.31 | 14.5 |
| 80 | 71.0 | 2.42 | 15.8 |
| 85 | 75.1 | 2.55 | 17.0 |
| 90 | 79.6 | 2.68 | 18.2 |
| 95 | 84.2 | 2.81 | 19.4 |
| 100 | 88.4 | 2.95 | 20.6 |
| 110 | 97.1 | 3.21 | 23.0 |
| 120 | 105.9 | 3.49 | 25.0 |
| 130 | 114.8 | 3.77 | 27.5 |
| 140 | 123.6 | 4.04 | 29.8 |
| 150 | 132.4 | 4.32 | 32.1 |
| 160 | 141.1 | 4.59 | 34.3 |
| 170 | 150.0 | 4.88 | 36.5 |
| 180 | 158.8 | 5.15 | 38.8 |
| 190 | 167.5 | 5.44 | 41.0 |
| 200 | 176.4 | 5.72 | 43.2 |
| 220 | 194.0 | 6.28 | 47.5 |
| 240 | 212 | 6.85 | 51.9 |
| 260 | 229 | 7.38 | 56.5 |
| 280 | 247 | 7.95 | 60.5 |
| 300 | 265 | 8.51 | 64.9 |
| 325 | 287 | 9.24 | 70.3 |
| 350 | 309 | 9.95 | 75.8 |
| 375 | 331 | 10.7 | 81.2 |
| 400 | 353 | 11.4 | 86.8 |
| 425 | 375 | 12.1 | 92.0 |
| 450 | 397 | 12.8 | 97.4 |
| 475 | 419 | 13.5 | 103 |
| 500 | 441 | 14.2 | 108 |
| 550 | 485 | 15.6 | 119 |
| 600 | 529 | 17.0 | 130 |
| 650 | 573 | 18.5 | 141 |
| 700 | 617 | 19.9 | 152 |
| 750 | 661 | 21.3 | 163 |
| 800 | 705 | 22.7 | 173 |
| 850 | 749 | 24.2 | 184 |
| 900 | 793 | 25.6 | 195 |
| 950 | 837 | 27.0 | 206 |
| 1000 | 882 | 28.4 | 217 |
| 1200 | 1058 | 34.1 | 260 |
| 1400 | 1234 | 39.8 | 302 |
| 1600 | 1411 | 45.5 | 347 |
| 1800 | 1587 | 51 | 390 |
| 2000 | 1763 | 57 | 433 |
| 2500 | 2204 | 71 | 542 |
| 3000 | 2646 | 85 | 650 |
| 3500 | 3087 | 99 | 758 |
| 4000 | 3526 | 114 | 867 |
| 4500 | 3967 | 128 | 974 |
| 5000 | 4408 | 142 | 1082 |
| 5500 | 4849 | 156 | 1150 |
| 6000 | 5290 | 170 | 1300 |
| 6500 | 5730 | 185 | 1400 |
| 7000 | 6171 | 199 | 1510 |
| 7500 | 6612 | 213 | 1630 |
| 8000 | 7053 | 227 | 1740 |
| 8500 | 7494 | 242 | 1850 |
| 9000 | 7934 | 256 | 1960 |
| 9500 | 8375 | 270 | 2070 |
| 10000 | 8816 | 284 | 2200 |

| TO CONVERT FROM | TO | MULTIPLY BY |
|--|---------------------------|---|
| Acceleration | | |
| foot/second ² | meter/second ² | m/s ² 0.3048 |
| inch/second ² | meter/second ² | m/s ² 0.0254 |
| Area | | |
| foot ² | meter ² | m ² 0.09290304 |
| inch ² | meter ² | m ² 0.00064516 |
| inch ² | millimeter ² | mm ² 645.16 |
| yard ² | meter ² | m ² 0.836127 |
| mile ² (U.S. statute) | meter ² | m ² 2589988 |
| Bending Moment or Torque | | |
| dyne-centimeter | newton-meter | N-m 0.000001 |
| kilogram-force-meter | newton-meter | N-m 9.806650 |
| pound-force-inch | newton-meter | N-m 0.1129848 |
| pound-force-foot | newton-meter | N-m 1.355818 |
| Energy | | |
| BTU (International Table) | joule | J 1055.056 |
| foot-pound-force | joule | J 1.355818 |
| kilowatt-hour | megajoule | MJ 3.6 |
| Force | | |
| kilogram-force | newton | N 9.806650 |
| kilopound-force | newton | N 9.806650 |
| pound-force (lbf avoirdupois) | newton | N 4.448222 |
| Length | | |
| fathom | meter | m 1.8288 |
| foot | meter | m 0.3048 |
| inch | millimeter | mm 25.4 |
| microinch | micrometer | µm 0.0254 |
| micron (µm) | millimeter | mm 0.0010 |
| mile (U.S. statute) | meter | m 1609.344 |
| yard | meter | m 0.9144 |
| nautical mile (UK) | meter | m 1853.18 |
| Mass | | |
| kilogram-force-second ² /meter (mass) | kilogram | kg 9.806650 |
| kilogram-mass | kilogram | kg 1.0 |
| pound-mass (lbm avoirdupois) | kilogram | kg 0.4535924 |
| ton (long, 2240 lbm) | kilogram | kg 1016.047 |
| ton (short, 2000 lbm) | kilogram | kg 907.1847 |
| tonn | kilogram | kg 1000.000 |
| Power | | |
| BTU (International Table)/hour | watt | W 0.293071 |
| BTU (International Table)/minute | watt | W 17.58427 |
| horsepower (550 ft lbf/s) | kilowatt | kW 0.745700 |
| BTU (thermochemical)/minute | watt | W 17.57250 |
| Pressure or Stress (Force/Area) | | |
| newton/meter ² | pascal | Pa 1.0000 |
| kilogram-force/centimeter ² | pascal | Pa 98066.50 |
| kilogram-force/meter ² | pascal | Pa 9.806650 |
| kilogram-force/millimeter ² | pascal | Pa 9806650 |
| pound-force/foot ² | pascal | Pa 47.88026 |
| pound-force/inch ² (psi) | megapascal | MPa 0.006894757 |
| Temperature | | |
| degree Celsius | kelvin | k t _c + 273.15 |
| degree Fahrenheit | kelvin | k k = 5/9 (t _f + 459.67) |
| degree Fahrenheit | Celsius | °C t _c = 5/9 (t _f - 32) |
| Velocity | | |
| foot/minute | meter/second | m/s 0.00508 |
| foot/second | meter/second | m/s 0.3048 |
| inch/second | meter/second | m/s 0.0254 |
| kilometer/hour | meter/second | m/s 0.27778 |
| mile/hour (U.S. statute) | meter/second | m/s 0.44704 |
| mile/hour (U.S. statute) | kilometer/hour | km/h 1.609344 |
| Volume | | |
| foot ³ | meter ³ | m ³ 0.02831685 |
| gallon (U.S. liquid) | liter | l 3.785412 |
| liter | meter ³ | m ³ 0.001 |
| inch ³ | meter ³ | m ³ 0.00001638706 |
| inch ³ | centimeter ³ | cm ³ 16.38706 |
| inch ³ | millimeter ³ | mm ³ 16387.06 |
| ounce (U.S. fluid) | centimeter ³ | cm ³ 29.57353 |
| yard ³ | meter ³ | m ³ 0.7645549 |

Conversion Chart Showing Millimeter, Fractional and Decimal Inch Sizes

| Fractional | Dec. Equiv. | Milli-meter | Fractional | Dec. Equiv. | Milli-meter | Fractional | Dec. Equiv. | Milli-meter | Fractional | Dec. Equiv. | Milli-meter | Fractional | Dec. Equiv. | Milli-meter |
|------------|-------------|-------------|------------|-------------|-------------|------------|-------------|-------------|------------|-------------|-------------|------------|-------------|-------------|
| 1/64" | .0039 | .1 | 5/64" | .0689 | 1.75 | 11/64" | .1570 | ... | 9/32" | .2677 | 6.8 | 27/64" | .4219 | 10.72 |
| | .0059 | .15 | | .0700 | ... | | .1575 | 4.0 | | .2716 | 6.9 | .4330 | 11.0 | |
| | .0079 | .2 | | .0709 | 1.8 | | .1590 | ... | | .2720 | ... | 7/16" | .4375 | 11.11 |
| | .0098 | .25 | | .0728 | 1.85 | | .1610 | ... | | .2756 | 7.0 | .4528 | 11.5 | |
| | .0118 | .3 | | .0730 | ... | | .1614 | 4.1 | | .2770 | ... | 29/64" | .4531 | 11.51 |
| | .0135 | ... | | .0748 | 1.9 | | .1654 | 4.2 | | .2795 | 7.1 | 15/32" | .4687 | 11.91 |
| | .0138 | .35 | | .0760 | ... | | .1660 | ... | | .2811 | ... | .4724 | 12.0 | |
| | .0145 | ... | | .0767 | 1.95 | | .1673 | 4.25 | | .2812 | 7.14 | 31/64" | .4843 | 12.30 |
| | .0156 | .39 | | .0781 | 1.98 | | .1693 | 4.3 | | .2835 | 7.2 | .4921 | 12.5 | |
| | .0157 | .4 | | .0785 | ... | | .1695 | ... | | .2854 | 7.25 | 1/2" | .5000 | 12.7 |
| | .0160 | ... | | .0787 | 2.0 | | .1719 | 4.37 | | .2874 | 7.3 | .5118 | 13.0 | |
| | .0177 | .45 | | .0807 | 2.05 | | .1730 | ... | | .2900 | ... | 33/64" | .5156 | 13.10 |
| .0180 | ... | .0810 | ... | .1732 | 4.4 | .2913 | 7.4 | 17/32" | .5312 | 13.49 | | | | |
| .0197 | .5 | .0820 | ... | .1770 | ... | .2950 | ... | .5315 | 13.5 | | | | | |
| .0200 | ... | .0827 | 2.1 | .1771 | 4.5 | .2953 | 7.5 | 35/64" | .5469 | 13.89 | | | | |
| .0210 | ... | .0846 | 2.15 | .1800 | ... | .2968 | 7.54 | .5512 | 14.0 | | | | | |
| .0217 | .55 | .0860 | ... | .1811 | 4.6 | .2992 | 7.6 | 9/16" | .5625 | 14.29 | | | | |
| .0225 | ... | .0866 | 2.2 | .1820 | ... | .3020 | ... | .5709 | 14.5 | | | | | |
| .0236 | .6 | .0885 | 2.25 | .1850 | 4.7 | .3031 | 7.7 | 37/64" | .5781 | 14.68 | | | | |
| .0240 | ... | .0890 | ... | .1870 | 4.75 | .3051 | 7.75 | .5906 | 15.0 | | | | | |
| .0250 | ... | .0905 | 2.3 | .1875 | 4.76 | .3071 | 7.8 | 19/32" | .5937 | 15.08 | | | | |
| .0256 | .65 | .0925 | 2.35 | .1890 | 4.8 | .3110 | 7.9 | 39/64" | .6094 | 15.48 | | | | |
| .0260 | ... | .0935 | ... | .1910 | ... | .3125 | 7.94 | .6102 | 15.5 | | | | | |
| .0280 | ... | .0937 | 2.38 | .1929 | 4.9 | .3150 | 8.0 | 5/8" | .6250 | 15.88 | | | | |
| .0276 | .7 | .0945 | 2.4 | .1935 | ... | .3160 | ... | .6299 | 16.0 | | | | | |
| .0292 | ... | .0960 | ... | .1960 | ... | .3189 | 8.1 | 41/64" | .6406 | 16.27 | | | | |
| .0295 | .75 | .0964 | 2.45 | .1968 | 5.0 | .3228 | 8.2 | .6496 | 16.5 | | | | | |
| .0310 | ... | .0980 | ... | .1990 | ... | .3230 | ... | 21/32" | .6562 | 16.67 | | | | |
| .0312 | .79 | .0984 | 2.5 | .2008 | 5.1 | .3248 | 8.25 | .6693 | 17.0 | | | | | |
| .0315 | .8 | .0995 | ... | .2010 | ... | .3268 | 8.3 | 43/64" | .6719 | 17.06 | | | | |
| .0320 | ... | .1015 | ... | .2031 | 5.16 | .3281 | 8.33 | 11/16" | .6875 | 17.46 | | | | |
| .0330 | ... | .1024 | 2.6 | .2040 | ... | .3307 | 8.4 | .6890 | 17.5 | | | | | |
| .0335 | .85 | .1040 | ... | .2047 | 5.2 | .3320 | ... | 45/64" | .7031 | 17.86 | | | | |
| .0350 | ... | .1063 | 2.7 | .2055 | ... | .3346 | 8.5 | .7087 | 18.0 | | | | | |
| .0354 | .9 | .1065 | ... | .2067 | 5.25 | .3386 | 8.6 | 23/32" | .7187 | 18.26 | | | | |
| .0360 | ... | .1082 | 2.75 | .2086 | 5.3 | .3390 | ... | .7283 | 18.5 | | | | | |
| .0370 | ... | .1094 | 2.78 | .2090 | ... | .3425 | 8.7 | 47/64" | .7344 | 18.65 | | | | |
| .0374 | .95 | .1100 | ... | .2126 | 5.4 | .3437 | 8.73 | 7480 | 19.0 | | | | | |
| .0380 | ... | .1102 | 2.8 | .2130 | ... | .3445 | 8.75 | 3/4" | .7500 | 19.05 | | | | |
| .0390 | ... | .1110 | ... | .2165 | 5.5 | .3465 | 8.8 | 49/64" | .7656 | 19.45 | | | | |
| .0394 | 1.0 | .1130 | ... | .2187 | 5.56 | .3480 | ... | .7677 | 19.5 | | | | | |
| .0400 | ... | .1141 | 2.9 | .2205 | 5.6 | .3504 | 8.9 | 25/32" | .7812 | 19.84 | | | | |
| .0410 | ... | .1160 | ... | .2210 | ... | .3543 | 9.0 | .7874 | 20.0 | | | | | |
| .0413 | 1.05 | .1181 | 3.0 | .2244 | 5.7 | .3580 | ... | 7969 | 20.24 | | | | | |
| .0420 | ... | .1200 | ... | .2263 | 5.75 | .3583 | 9.1 | 8071 | 20.5 | | | | | |
| .0430 | ... | .1220 | 3.1 | .2280 | ... | .3594 | 9.13 | 13/16" | .8125 | 20.64 | | | | |
| .0433 | 1.1 | .1250 | 3.18 | .2283 | 5.8 | .3622 | 9.2 | .8268 | 21.0 | | | | | |
| .0452 | 1.15 | .1260 | 3.2 | .2323 | 5.9 | .3641 | 9.25 | 53/64" | .8281 | 21.03 | | | | |
| .0465 | ... | .1279 | 3.25 | .2340 | ... | .3661 | 9.3 | 27/32" | .8437 | 21.43 | | | | |
| .0469 | 1.19 | .1285 | ... | .2344 | 5.95 | .3680 | ... | .8465 | 21.5 | | | | | |
| .0472 | 1.2 | .1299 | 3.3 | .2362 | 6.0 | .3701 | 9.4 | 55/64" | .8594 | 21.83 | | | | |
| .0492 | 1.25 | .1338 | 3.4 | .2380 | ... | .3740 | 9.5 | .8661 | 22.0 | | | | | |
| .0512 | 1.3 | .1360 | ... | .2401 | 6.1 | .3750 | 9.53 | 7/8" | .8750 | 22.23 | | | | |
| .0520 | ... | .1378 | 3.5 | .2420 | ... | .3770 | ... | .8858 | 22.5 | | | | | |
| .0531 | 1.35 | .1405 | ... | .2441 | 6.2 | .3780 | 9.6 | 57/64" | .8906 | 22.62 | | | | |
| .0550 | ... | .1406 | 3.57 | .2460 | 6.25 | .3819 | 9.7 | .9055 | 23.0 | | | | | |
| .0551 | 1.4 | .1417 | 3.6 | .2480 | 6.3 | .3838 | 9.75 | 29/32" | .9062 | 23.02 | | | | |
| .0570 | 1.45 | .1440 | ... | .2500 | 6.35 | .3858 | 9.8 | 59/64" | .9219 | 23.42 | | | | |
| .0591 | 1.5 | .1457 | 3.7 | .2520 | 6.4 | .3860 | ... | .9252 | 23.5 | | | | | |
| .0595 | ... | .1470 | ... | .2559 | 6.5 | .3898 | 9.9 | 15/16" | .9375 | 23.81 | | | | |
| .0610 | 1.55 | .1476 | 3.75 | .2570 | ... | .3906 | 9.92 | .9449 | 24.0 | | | | | |
| .0625 | 1.59 | .1495 | ... | .2598 | 6.6 | .3937 | 10.0 | 61/64" | .9531 | 24.21 | | | | |
| .0629 | 1.6 | .1496 | 3.8 | .2610 | ... | .3970 | ... | .9646 | 24.5 | | | | | |
| .0635 | ... | .1520 | ... | .2638 | 6.7 | .4040 | ... | 31/32" | .9687 | 24.61 | | | | |
| .0649 | 1.65 | .1535 | 3.9 | .2656 | 6.75 | .4062 | 10.32 | .9843 | 25.0 | | | | | |
| .0669 | 1.7 | .1540 | ... | .2657 | 6.75 | .4130 | ... | 63/64" | .9844 | 25.03 | | | | |
| .0670 | ... | .1562 | 3.97 | .2660 | ... | .4134 | 10.5 | 1" | 1.000 | 25.4 | | | | |

Temperature Conversion Table

This conversion table can be used to convert temperature to Celsius (°C) or to Fahrenheit (°F). The center column is the base temperature. If you want to convert from °F to °C, you would look up the number in the center column and the number in the left column would show the conversion in °C. To convert °C to °F, you would look up the base number and the conversion to °F is shown in the right column.

As an example, to find the °F for 100° C, look up 100 in the base temperature column. The column to the right shows +212° F as the conversion. **The shaded portions of the chart represent negative values.**

| | BASE TEMP. | | | BASE TEMP. | | | BASE TEMP. | | | BASE TEMP. | | | BASE TEMP. | |
|--------|------------|--------|-------|------------|-------|--------|------------|-------|--------|------------|------|--------|------------|------|
| °C | °For °C | °F | °C | °For °C | °F | °C | °For °C | °F | °C | °For °C | °F | °C | °For °C | °F |
| -73.33 | -100 | -148.0 | -1.11 | 30 | 86.0 | 40.56 | 105 | 221.0 | 148.89 | 300 | 572 | 357.22 | 675 | 1247 |
| 70.55 | 95 | 139.0 | 0.56 | 31 | 87.8 | 41.11 | 106 | 222.8 | 151.67 | 305 | 581 | 360.00 | 680 | 1256 |
| 67.78 | 90 | 130.0 | 0.00 | 32 | 89.6 | 41.67 | 107 | 224.6 | 154.44 | 310 | 590 | 362.78 | 685 | 1265 |
| 65.00 | 85 | 121.0 | 0.56 | 33 | 91.4 | 42.22 | 108 | 226.4 | 157.22 | 315 | 599 | 365.56 | 690 | 1274 |
| 62.22 | 80 | 112.0 | 1.11 | 34 | 93.2 | 42.78 | 109 | 228.2 | 160.00 | 320 | 608 | 368.34 | 695 | 1283 |
| 59.44 | 75 | 103.0 | 1.67 | 35 | 95.0 | 43.33 | 110 | 230.0 | 162.78 | 325 | 617 | 371.11 | 700 | 1292 |
| 56.67 | 70 | 94.0 | 2.22 | 36 | 96.8 | 43.89 | 111 | 231.8 | 165.56 | 330 | 626 | 373.89 | 705 | 1301 |
| 53.89 | 65 | 85.0 | 2.78 | 37 | 98.6 | 44.44 | 112 | 233.6 | 168.33 | 335 | 635 | 376.67 | 710 | 1310 |
| 51.11 | 60 | 76.0 | 3.33 | 38 | 100.4 | 45.00 | 113 | 235.4 | 171.11 | 340 | 644 | 379.44 | 715 | 1319 |
| 48.33 | 55 | 67.0 | 3.89 | 39 | 102.2 | 45.56 | 114 | 237.2 | 173.89 | 345 | 653 | 382.22 | 720 | 1328 |
| 45.56 | 50 | 58.0 | 4.44 | 40 | 104.0 | 46.11 | 115 | 239.0 | 176.67 | 350 | 662 | 385.00 | 725 | 1337 |
| 44.44 | 48 | 54.4 | 5.00 | 41 | 105.8 | 46.67 | 116 | 240.8 | 179.44 | 355 | 671 | 387.78 | 730 | 1346 |
| 43.33 | 46 | 50.8 | 5.56 | 42 | 107.6 | 47.22 | 117 | 242.6 | 182.22 | 360 | 680 | 390.56 | 735 | 1355 |
| 42.22 | 44 | 47.2 | 6.11 | 43 | 109.4 | 47.78 | 118 | 244.4 | 185.00 | 365 | 689 | 393.33 | 740 | 1364 |
| 41.11 | 42 | 43.6 | 6.67 | 44 | 111.2 | 48.33 | 119 | 246.2 | 187.78 | 370 | 698 | 396.11 | 745 | 1373 |
| 40.00 | 40 | 40.0 | 7.22 | 45 | 113.0 | 48.87 | 120 | 248.0 | 190.56 | 375 | 707 | 398.89 | 750 | 1382 |
| 38.89 | 38 | 36.4 | 7.78 | 46 | 114.8 | 49.44 | 121 | 249.8 | 193.33 | 380 | 716 | 401.67 | 755 | 1391 |
| 37.78 | 36 | 32.8 | 8.33 | 47 | 116.6 | 50.00 | 122 | 251.6 | 196.11 | 385 | 725 | 404.44 | 760 | 1400 |
| 36.67 | 34 | 29.2 | 8.89 | 48 | 118.4 | 50.56 | 123 | 253.4 | 198.89 | 390 | 734 | 407.22 | 765 | 1409 |
| 35.56 | 32 | 25.6 | 9.44 | 49 | 120.2 | 51.11 | 124 | 255.2 | 201.67 | 395 | 743 | 410.00 | 770 | 1418 |
| 34.44 | 30 | 22.0 | 10.00 | 50 | 122.0 | 51.67 | 125 | 257.0 | 204.44 | 400 | 752 | 412.78 | 775 | 1427 |
| 33.33 | 28 | 18.4 | 10.56 | 51 | 123.8 | 52.22 | 126 | 258.8 | 207.22 | 405 | 761 | 415.56 | 780 | 1436 |
| 32.22 | 26 | 14.8 | 11.11 | 52 | 125.6 | 52.78 | 127 | 260.6 | 210.00 | 410 | 770 | 418.33 | 785 | 1445 |
| 31.11 | 24 | 11.2 | 11.67 | 53 | 127.4 | 53.33 | 128 | 262.4 | 212.78 | 415 | 779 | 421.11 | 790 | 1454 |
| 30.00 | 22 | 7.6 | 12.22 | 54 | 129.2 | 53.89 | 129 | 264.2 | 215.56 | 420 | 788 | 423.89 | 795 | 1463 |
| 28.89 | 20 | 4.0 | 12.78 | 55 | 131.0 | 54.44 | 130 | 266.0 | 218.33 | 425 | 797 | 426.67 | 800 | 1472 |
| 28.33 | 19 | 2.2 | 13.33 | 56 | 132.8 | 55.00 | 131 | 267.8 | 221.11 | 430 | 806 | 429.44 | 805 | 1481 |
| 27.78 | 18 | 0.4 | 13.89 | 57 | 134.6 | 55.56 | 132 | 269.6 | 223.89 | 435 | 815 | 432.22 | 810 | 1490 |
| 27.22 | 17 | 1.4 | 14.44 | 58 | 136.4 | 56.11 | 133 | 271.4 | 226.67 | 440 | 824 | 435.00 | 815 | 1499 |
| 26.67 | 16 | 3.2 | 15.00 | 59 | 138.2 | 56.67 | 134 | 273.2 | 229.44 | 445 | 833 | 437.78 | 820 | 1508 |
| 26.11 | 15 | 5.0 | 15.56 | 60 | 140.0 | 57.22 | 135 | 275.0 | 232.22 | 450 | 842 | 440.56 | 825 | 1517 |
| 25.56 | 14 | 6.8 | 16.11 | 61 | 141.8 | 57.78 | 136 | 276.8 | 235.00 | 455 | 851 | 443.33 | 830 | 1526 |
| 25.00 | 13 | 8.6 | 16.67 | 62 | 143.6 | 58.33 | 137 | 278.6 | 237.78 | 460 | 860 | 446.11 | 835 | 1535 |
| 24.44 | 12 | 10.4 | 17.22 | 63 | 145.4 | 58.89 | 138 | 280.4 | 240.56 | 465 | 869 | 448.89 | 840 | 1544 |
| 23.89 | 11 | 12.2 | 17.78 | 64 | 147.2 | 63.44 | 139 | 282.2 | 243.33 | 470 | 878 | 451.67 | 845 | 1553 |
| 23.33 | 10 | 14.0 | 18.33 | 65 | 149.0 | 60.00 | 140 | 284.0 | 246.11 | 475 | 887 | 454.44 | 850 | 1562 |
| 22.78 | 9 | 15.8 | 18.89 | 66 | 150.8 | 60.56 | 141 | 285.8 | 248.89 | 480 | 896 | 457.22 | 855 | 1571 |
| 22.22 | 8 | 17.6 | 19.44 | 67 | 152.6 | 61.11 | 142 | 287.6 | 251.67 | 485 | 905 | 460.00 | 860 | 1580 |
| 21.67 | 7 | 19.4 | 20.00 | 68 | 154.4 | 61.67 | 143 | 289.4 | 254.44 | 490 | 914 | 462.78 | 865 | 1589 |
| 21.11 | 6 | 21.2 | 20.56 | 69 | 156.2 | 62.22 | 144 | 291.2 | 257.22 | 495 | 923 | 465.56 | 870 | 1598 |
| 20.56 | 5 | 23.0 | 21.11 | 70 | 158.0 | 62.78 | 145 | 293.0 | 260.00 | 500 | 932 | 468.33 | 875 | 1607 |
| 20.00 | 4 | 24.8 | 21.67 | 71 | 159.8 | 63.33 | 146 | 294.8 | 262.78 | 505 | 941 | 471.11 | 880 | 1616 |
| 19.44 | 3 | 26.6 | 22.22 | 72 | 161.6 | 63.89 | 147 | 296.6 | 265.56 | 510 | 950 | 473.89 | 885 | 1625 |
| 18.89 | 2 | 28.4 | 22.78 | 73 | 163.4 | 64.44 | 148 | 298.4 | 268.33 | 515 | 959 | 476.67 | 890 | 1634 |
| 18.33 | 1 | 30.2 | 23.33 | 74 | 165.2 | 65.00 | 149 | 300.2 | 271.11 | 520 | 968 | 479.44 | 895 | 1643 |
| 17.78 | 0 | 32.0 | 23.89 | 75 | 167.0 | 65.56 | 150 | 302.0 | 273.89 | 525 | 977 | 482.22 | 900 | 1652 |
| 17.22 | 1 | 33.8 | 24.44 | 76 | 168.8 | 66.11 | 151 | 311.0 | 276.67 | 530 | 986 | 485.00 | 905 | 1661 |
| 16.67 | 2 | 35.6 | 25.00 | 77 | 170.6 | 71.11 | 160 | 320.0 | 279.44 | 535 | 995 | 487.78 | 910 | 1670 |
| 16.11 | 3 | 37.4 | 25.56 | 78 | 172.4 | 73.89 | 165 | 329.0 | 282.22 | 540 | 1004 | 490.56 | 915 | 1679 |
| 15.56 | 4 | 39.2 | 26.11 | 79 | 174.2 | 76.67 | 170 | 338.0 | 285.00 | 545 | 1013 | 493.33 | 920 | 1688 |
| 15.00 | 5 | 41.0 | 26.67 | 80 | 176.0 | 79.44 | 175 | 347.0 | 287.78 | 550 | 1022 | 496.11 | 925 | 1697 |
| 14.44 | 6 | 42.8 | 27.22 | 81 | 177.8 | 82.22 | 180 | 356.0 | 290.56 | 555 | 1031 | 498.89 | 930 | 1706 |
| 13.89 | 7 | 44.6 | 27.78 | 82 | 179.6 | 85.00 | 185 | 365.0 | 293.33 | 560 | 1040 | 501.67 | 935 | 1715 |
| 13.33 | 8 | 46.4 | 28.33 | 83 | 181.4 | 87.78 | 190 | 374.0 | 296.11 | 565 | 1049 | 504.44 | 940 | 1724 |
| 12.78 | 9 | 48.2 | 28.89 | 84 | 183.2 | 90.56 | 195 | 383.0 | 298.89 | 570 | 1058 | 507.22 | 945 | 1733 |
| 12.22 | 10 | 50.0 | 29.44 | 85 | 185.0 | 93.33 | 200 | 392.0 | 301.67 | 575 | 1067 | 510.00 | 950 | 1742 |
| 11.67 | 11 | 51.8 | 30.00 | 86 | 186.8 | 96.11 | 205 | 401.0 | 304.44 | 580 | 1076 | 512.78 | 955 | 1751 |
| 11.11 | 12 | 53.6 | 30.56 | 87 | 188.6 | 98.89 | 210 | 410.0 | 307.22 | 585 | 1085 | 515.56 | 960 | 1760 |
| 10.56 | 13 | 55.4 | 31.11 | 88 | 190.4 | 101.67 | 215 | 419.0 | 310.00 | 590 | 1094 | 518.33 | 965 | 1769 |
| 10.00 | 14 | 57.2 | 31.67 | 89 | 192.2 | 104.44 | 220 | 428.0 | 312.78 | 595 | 1103 | 521.11 | 970 | 1778 |
| 9.44 | 15 | 59.0 | 32.22 | 90 | 194.0 | 107.22 | 225 | 437.0 | 315.56 | 600 | 1112 | 523.89 | 975 | 1787 |
| 8.89 | 16 | 60.8 | 32.78 | 91 | 195.8 | 110.00 | 230 | 446.0 | 318.33 | 605 | 1121 | 526.67 | 980 | 1796 |
| 8.33 | 17 | 62.6 | 33.33 | 92 | 197.6 | 112.78 | 235 | 455.0 | 321.11 | 610 | 1130 | 529.44 | 985 | 1805 |
| 7.78 | 18 | 64.4 | 33.89 | 93 | 199.4 | 115.56 | 240 | 464.0 | 323.89 | 615 | 1139 | 532.22 | 990 | 1814 |
| 7.22 | 19 | 66.2 | 34.44 | 94 | 201.2 | 118.33 | 245 | 473.0 | 326.67 | 620 | 1148 | 535.00 | 995 | 1823 |
| 6.67 | 20 | 68.0 | 35.00 | 95 | 203.0 | 121.11 | 250 | 482.0 | 329.44 | 625 | 1157 | 537.78 | 1000 | 1832 |
| 6.11 | 21 | 69.8 | 35.56 | 96 | 204.8 | 123.89 | 255 | 491.0 | 332.22 | 630 | 1166 | 540.56 | 1005 | 1841 |
| 5.56 | 22 | 71.6 | 36.11 | 97 | 206.6 | 126.67 | 260 | 500.0 | 335.00 | 635 | 1175 | 543.33 | 1010 | 1850 |
| 5.00 | 23 | 73.4 | 36.67 | 98 | 208.4 | 129.44 | 265 | 509.0 | 337.78 | 640 | 1184 | 546.11 | 1015 | 1859 |
| 4.44 | 24 | 75.2 | 37.22 | 99 | 210.2 | 132.22 | 270 | 518.0 | 340.56 | 645 | 1193 | 548.89 | 1020 | 1868 |
| 3.89 | 25 | 77.0 | 37.78 | 100 | 212.0 | 135.00 | 275 | 527.0 | 343.33 | 650 | 1202 | 551.67 | 1025 | 1877 |
| 3.33 | 26 | 78.8 | 38.33 | 101 | 213.8 | 137.78 | 280 | 536.0 | 346.11 | 655 | 1211 | 554.44 | 1030 | 1886 |
| 2.78 | 27 | 80.6 | 38.89 | 102 | 215.6 | 140.56 | 285 | 545.0 | 348.89 | 660 | 1220 | 557.22 | 1035 | 1895 |
| 2.22 | 28 | 82.4 | 39.44 | 103 | 217.4 | 143.33 | 290 | 554.0 | 351.67 | 665 | 1229 | 560.00 | 1040 | 1904 |
| 1.67 | 29 | 84.2 | 40.00 | 104 | 219.2 | 146.11 | 295 | 563.0 | 354.44 | 670 | 1238 | 562.78 | 1045 | 1913 |

Making it Easy to Succeed

We provide the products and support necessary to meet your goals by providing tailored solutions that offer performance and convenience.

From breadth of product to product quality, our friction management solutions satisfy a wide range of needs, giving you the ability to add lasting value for your customers.

Friction Management Solutions®

Quality Bearings

Timken® bearings are made from the cleanest bearing steel in the industry. Tapered, spherical, cylindrical and ball bearings that bear the Timken name are known for quality, durability and performance.

Performance Bearings

Timken® super precision products as well as Timken® Spexx™ high-performance bearings move traditional tapered, spherical, cylindrical and ball bearings to a new level. Through enhanced steel, changes in geometry and applying surface finishes on rollers and raceways that resist debris contamination, bearing life can be extended.



Housed Units

Spherical roller bearing and ball bearing housed units, available with Timken Shaft Guarding Technology™, feature a unique sealing system. These units are easily installed and maintained in heavy-duty environments.

Integrated Bearing Packages

Self-contained, bundled bearing packages ease installation in automotive, rail, wind power and other applications. Timken's sensor technology can track critical data.

Timken Reliability Services

Timken offers integrated maintenance and training services and diagnostic analysis to help customers gain an advantage. We approach maintenance from multiple fronts to give you the customized solution you need to improve performance and maximize uptime.

Hub Unit Bearings

These pre-sealed, pre-lubricated and pre-set integrated hub and bearing units can be bolted directly onto passenger car and light truck wheel corners, eliminating the need for conventional components like washers, spacers and nuts. They can incorporate sensor technology for traction control, anti-lock braking systems and other vehicle systems.



IsoClass® Bearings

For markets that require metric dimensions, Timken's broad line of IsoClass bearings bring high-quality performance to applications requiring conformance to ISO and DIN requirements.

Solid-Lube Bearings

Solid-lube bearings combine a mixture of polymers, oils and other additives that can be customized for your specific bearing lubrication requirements. Primary metals, mining, power generation and automotive MRO are some typical industries where solid lube bearings are used successfully.

Friction Management Solutions® – *continued*

Safety End Caps

These easily installed caps offer a high degree of protection to maintenance personnel as well as to the bearings integrated within a housing.

Engineered Surfaces

With more than 50 years invested in the study of surface finishes, Timken offers a selection of topographical modifications and hard coatings that enhance the wear, fatigue and frictional performance of many precision components. Timken Engineered Surfaces technology is applicable in rolling, sliding or mixed contact systems where fatigue spalling, inadequate lubrication, pitting, false brinelling or peeling damage modes may exist. Common applications include engine components, bearings, hydrostatics and gears.

Seals and Bearing Isolators

Bearing seals and isolators protect the bearing from contaminants to enhance performance and bearing life.

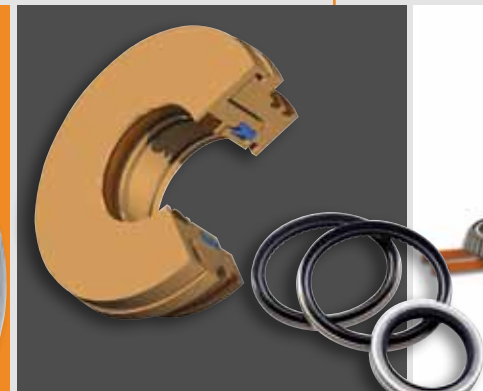

Condition Monitoring Devices

From wireless units to online systems, conditioning monitoring devices give you powerful diagnostic tools to help detect potential bearing failure, maximize machine uptime and lower maintenance costs.

Single- and Multi-point Lubricators

Timken® lubricators are available in single- and multi-point units to help ensure consistent, regular lubrication to bearings, gears and conveyors, improving component life and reducing maintenance labor costs.

Lubrication Delivery Devices

For a Timken® bearing to operate properly, it is essential for it to receive proper lubrication. Timken grease guns and pumps are high-quality maintenance products that help decrease both machinery downtime and operating costs.

Installation and Removal Tools

Convenient, easy-to-carry kits give technicians the tools they need to install, remove and service bearings, gears and rings. Products include: impact fitting tools, induction heaters and mechanical pullers.

Infrared Thermometers

Timken non-contact infrared thermometers are portable, lightweight solutions for safely measuring temperature from a distance.



Lubricants

Industrial lubricant formulas have been specifically developed by our lubrication experts. These lubricants keep bearings running smoothly in a variety of industrial conditions, including high heat, food processing and high speed.



www.timken.com

Timken's Web site is a valuable resource that incorporates user-friendly features and enables customers to learn more about our broad portfolio of products and services.

Knowledgeable Sales Professionals

Working with you as a team, Timken sales representatives are extensively trained in the specification and application of bearings, related products and value-added services. From bearing basics to highly technical matters, you can rely on your salesperson to help you make your business even more successful.



Spindle Rebuild and Management Service

Our single-source service includes spindle repair as well as predictive maintenance programs, failure mode analysis and spindle performance tracking to help improve operation and reduce downtime.

Repair and Replacement Options

By choosing to have bearings and other mill elements remanufactured, customers save money in replacement costs and maintain a steady supply of parts instead of purchasing new parts during downtimes.





TIMKEN

Where You Turn

Bearings • Steel •
Power Transmission Systems •
Precision Components • Seals •
Lubrication • Industrial Services •
Remanufacture and Repair

www.timken.com



2.5M 06-11: 29 Order No. 5892

Timken® and Where You Turn® are registered trademarks of The Timken Company. • © 2011 The Timken Company • Printed in U.S.A.