

**RECEIVER  
CONTROLLER  
MODEL RC 1T2A  
(S/N 10000 and Above)  
FIELD SERVICE INSTRUCTIONS  
Rev-1**

THIS DOCUMENT EMBODIES A PROPRIETARY DESIGN ORIGINATED BY CONTROL INDUSTRIES, INC., AND SHALL NOT BE DISCLOSED, USED, OR DUPLICATED FOR PROCUREMENT OR MANUFACTURING PURPOSES, UNLESS SPECIFICALLY AUTHORIZED BY CONTROL INDUSTRIES, INC.

Control Industries Inc.  
614 Central Ave.  
Findlay, Ohio 45840  
TEL 419-800-0011  
FAX 419-500-9015

**HANDBOOK OF OPERATING AND MAINTENANCE  
INSTRUCTIONS  
RECEIVER CONTROLLER RC-1T2A**

**1.0 GENERAL:**

The model RC-1T2A controller has been specifically designed to provide remote control of airport lighting systems which require only one control function. This control system will allow the approaching pilot to turn the runway lights on at his discretion. The RC-1T2A is enclosed in a weather-proof water-tight housing and is conservatively designed for continuous outdoor unattended operation.

The RC-1T2A receiver controller complies with FCC rules and regulations Part 15.

**2.0 ELECTRICAL:**

The receiver is an integrated-circuit design. The sensitivity is adjustable from 1 microvolt to 30 microvolts as desired by the user, permitting a control range of 1 to 20 miles. Receivers are shipped normally adjusted to a sensitivity of 10 microvolts. The unit is designed to operate from 120 volt  $\pm 20\%$  50-60 HZ single phase power.

**3.0 THEORY OF OPERATION:**

The system is activated by counting pulses of R.F. energy withing a 5 second timing period.

After receipt of five pulses during that period the relay K1 closes, sending 120vac to the Control One terminal.

The solid-state timer will continue to operate for 15 minutes after which it will cause the system to revert to the original "off" condition. The timer is reset by the receipt of five pulses at any time, reinitiating the 15 minute "run" cycle. The operating time may be selected in 15-minute increments from 15 minutes to 1 hour by setting switches on the Receiver Board.

During testing, the 15-minute operating period may be terminated by pressing the Reset Switch on the base assembly.

The solid-state receiver-controller is composed of three printed circuit cards which include the Interface/Power Supply board, Relay Board, and Receiver/Decoder Board. The following describes the theory of operation for each of the receiver-controller basic elements.

Reference: Functional Diagram Figure A.

**FIG A**  
**Functional Diagram**

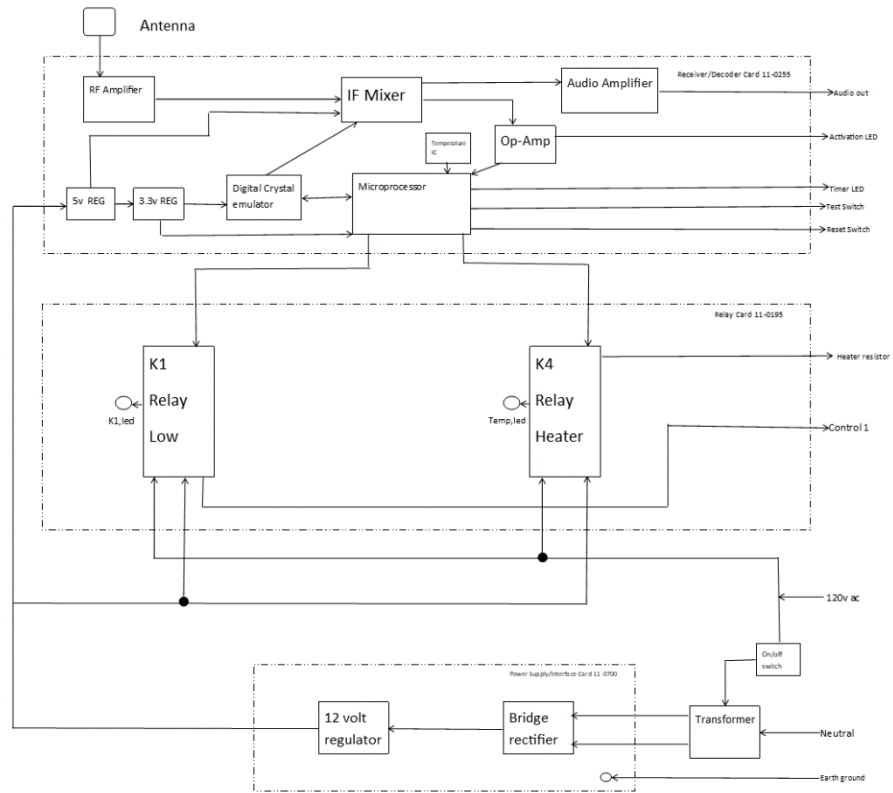

**FIG B**  
**INTERCONNECTING WIRING DIAGRAM**  
**(with Lightning Suppression Components)**

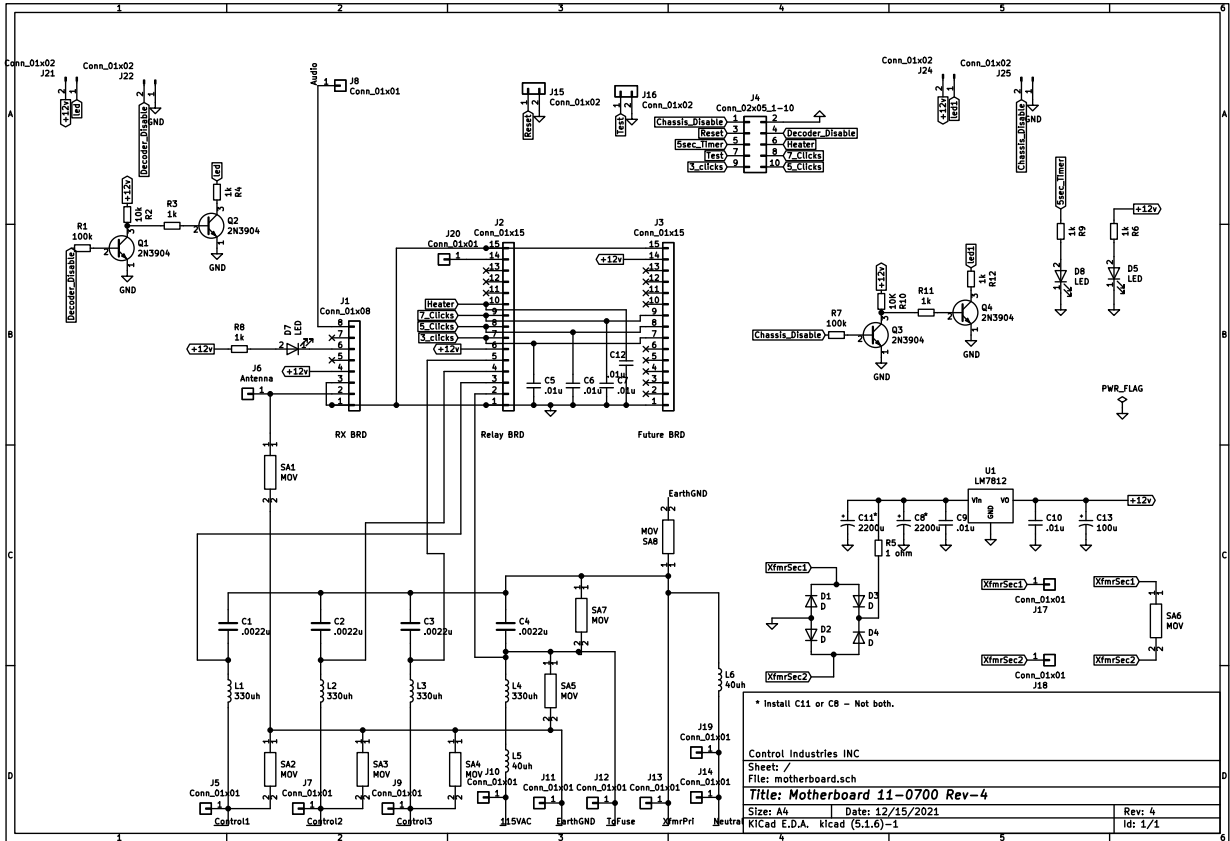

### 3.1 RADIO FREQUENCY/DECODER CARD (C.I. PART #11-0255)

The radio receiver is a superheterodyne design operating at a nominal R.F. frequency within the VHF band of 118 to 136 MHz. An IF frequency of 10.7 MHz is utilized with the bandwidth controlled by a 6-pole crystal lattice filter. This filter establishes nominal -60 db rejection at adjacent channel frequencies of  $\pm 25$  KHz or more. It also establishes an on-frequency bandwidth of nominally  $\pm 9$  KHz at the -6.0 db points. A communications type integrated circuit provides the IF gain, AM detection, RSSI and audio output. The audio output is buffered and delivered to a service jack for maintenance and test purposes. A red LED indicator is included on the receiver card to visibly show the state of the receiver logic. A microprocessor IC is programmed to count the RF pulses and send the command to turn on the appropriate relays. The Timer function is programmed into the microprocessor and can be adjusted in 15-minute intervals up to 1 hour by adjusting the dip switch settings. The microprocessor monitors a temperature IC and activates a relay to power a chassis mounted resistor to provide heat in freezing conditions.

FIG C  
RECEIVER CARD 11-0255

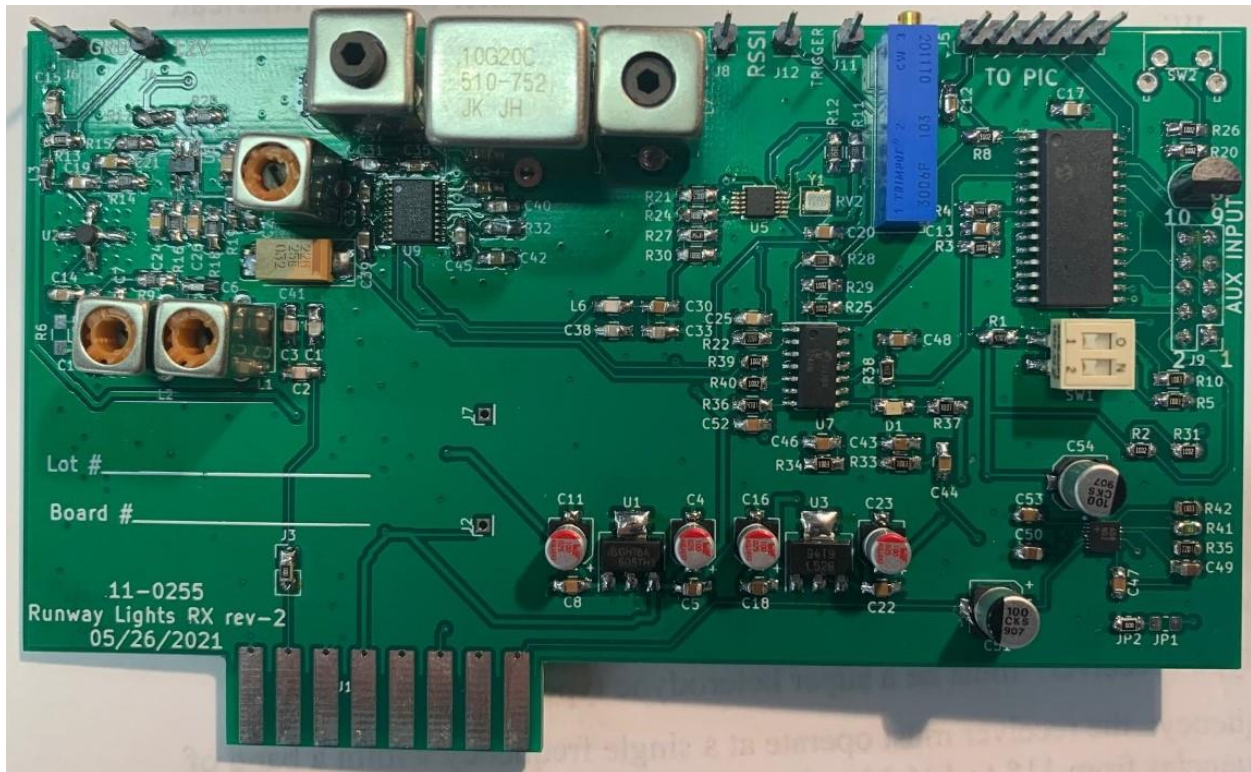

### 3.2 RELAY CARD (C.I. PART # 11-0195):

The output relays, K-1, K-2, K-3, and K-4 and their associated components, resistors R-2, R-4, R-6,R-8; indicator LED's D-2, D-4, D-6, D-8; diodes D-1, D-3, D-5, D-7; resistors R-1, R-3, R-5, R-7 and capacitors C-1, C-2, C-3, and C-4 are contained on their own printed circuit card, P/N 11-0195. The relays and timer function are controlled by the microprocessor on the receiver/decoder card 11-0255.

Diodes D-1, D-3, D-5, and D-7 are connected inversely across the relay coils to suppress the inductive transient when the relays are turned off.

Resistors R-2, R-4, R-6, R-8 and LED indicators D-3, D-4, D-6, D-8 show when the relays have been activated. The LEDs will be visible when the printed circuit board cover is in place.

Resistors R-1, R-3, R-5, R-7 and capacitors C-1 thru C-4 form arc suppression networks to reduce transient noise when the relays deactivate the load relays. This arc suppression also increases relay life.

In case the load relays have very high coil impedance, keeping the loads energized after K-1 are shut off, the arc suppression networks may be disabled by removing capacitor C-1

K-4 is the heater control relay and has a green LED to indicate when the heater resistor is powered and heating.

**Fig D**  
**Plug-in Relay Assembly 11-0195T2**

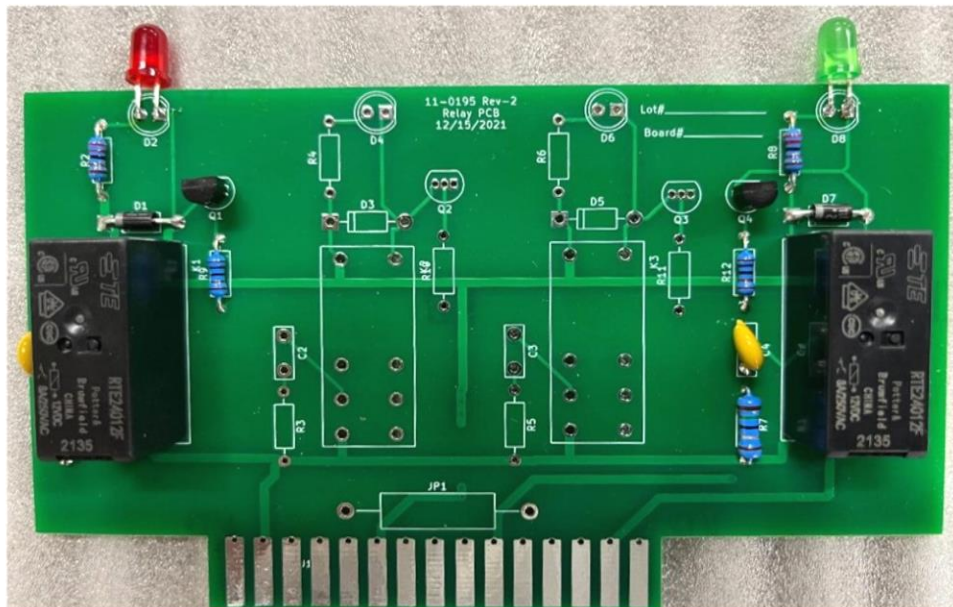

#### 4.0 TROUBLE ANALYSIS:

A malfunction chart including several possible failure modes is supplied to assist the technician in analyzing the probable cause. The receiver-controller is warranted for one year from date of purchase. Failures not caused by improper installation or abnormal treatment will be corrected by the manufacturer free of charge within the warranty period.

#### 4.1 TROUBLE ANALYSIS CHART:

The following tabulations will provide guidance for recognizing possible trouble and correction.

<i>MALFUNCTION</i>	<i>POSSIBLE CAUSE</i>	<i>TEST AND REMEDY</i>
AC voltage present but no DC LED indication	Open 1.0 A. Fuse	Test & Replace
	Bad AC Switch	Test & Replace
	Defect in power supply. electronic board, power transformer or series regulator transistors	Return receiver to manufacturer for service.
DC OK, no LED indication, no audio	Defect in receiver card part number 11-0255	Replace card, retest. Send defective card to manufacturer for repair or replacement if in warranty.
DC OK Relay closures normal No output voltage any control line	Open 5A SLO BLO Fuse	Test & Replace fuse with same type only
Failure to reset Timer indicator after 5 seconds	Defective Receiver/Decoder card, number 11-0255	Use replacement card and retest. Return defective card to manufacturer for repair or replacement if in warranty.
Fails to turn off after 15 minutes	Defective Receiver/Decoder Card, Part number 11-0255	Use replacement card and retest. Return defective card to manufacturer for repair or replacement if in warranty.
DC O.K., output indicator LED's Normal	Defective Relay K-1, K-2, or K-3, whichever circuit is defective	Replace Relay Card P/N 11-0195 and retest.

## 5.0 MAINTENANCE:

The Model RC-1T5A is designed to require a minimum of maintenance under all ranges of service conditions. There are no moving parts except the output contactor relays. With proper installation, no abuse or tampering, the unit should deliver at least 10,000 hours of trouble-free operation.

### 5.1 MAINTENANCE CONCEPT:

The unit may be maintained readily by technician level personnel. **The printed circuit boards are not readily repairable in the field. Return defective printed circuit boards to Control Industries for repair / replacement by the manufacturer.** A stock of one each substitute cards should be retained to verify a suspected defective card by simple substitution procedures. All other elements of the receiver-controller may readily be checked utilizing normal electrical test procedures involving no special testing equipment other than a standard volt-ohmmeter. A standard headset may be used to monitor the receiver at the audio jack.

### 5.2 OPERATING CHECKOUT:

The service technician may determine proper operation of the receiver-controller by completing the following checklist:

- (1) Check the presence of primary line voltage as measured between input terminals marked 115VAC and neutral.
- (2) Press AC power switch and observe Green DC power indicating LED inside the controller housing. Illumination of this DC indicator implies proper power supply operation.
- (3) Depress red test button five consecutive times within five seconds. This result is closure of Relay K-1 and the illumination of the red LED indicator adjacent to relay K-1 on the Relay Card.
- (4) After elapse of 5 seconds the timer indicator should extinguish.
- (5) Depress white reset button and confirm all relays and light go out.
- (6) Place a short across Remote Disable terminals. Verify light next to terminals lights. Verify that when test button is pressed three, five, or seven times no relays close. Remove short.
- (7) Place the Decoder Disable switch in the on position. Verify light next to switch lights. Press red test button seven times within 5 Seconds. Wait for the timer light to go out. Press the red test button three, five and seven times to verify that the output does not change. Wait 15 minutes for the timer to disable the relays. Press red test button three, five, or seven times to verify ability to reactivate after timeout.

The above procedures accomplish a complete operating check of all elements and functions of the Receiver-Controller RC-1T2A.



### 5.3 DETAILED MAINTENANCE INSTRUCTIONS:

If during the performance of check out as specified in paragraph 4.1 improper operation is noted, the following explanations and instruction procedures will simplify servicing the controller:

#### 5.3.1 POWER SUPPLY:

It should first be determined that proper power 115V AC, 60 cycles is being applied to the input connector terminals labeled 115V AC and Neutral (Figure K). This may be determined by use of a suitable volt-ohmmeter; Simpson Model 260 or equivalent.

The power supply Circuit is located on the main interface PCB and is not field serviceable. All power supply electronics are located on this PCB except the power transformer (T-1) located on the main chassis as depicted in Figure K. A green LED indicator is provided to indicate presence of 12 volts DC. This indicator is the lower-most of a series of indicators located on the right-hand side of the PC board cover. This indicator glows green at all times when the receiver is turned on and D.C. is present. The location of this D.C. power indicator is depicted in Figure K.

Indication of the presence of A.C. power as measured by an appropriate A.C. voltmeter and failure of the D.C. indicator indicates a Main Interface PCB failure. The following steps should be accomplished in sequence. Verify proper output voltage from Power Transformer.(T-1) The output voltage of the power transformer should be approximately 16V AC. Remove the Receiver/Decoder, and Relay cards one at a time and observe the D.C. indicator. This procedure removes and isolates any possible shorts in the relay or radio boards. Recheck for proper D.C. indicator operation. If a failure remains, contact Control Industries Inc. to further troubleshoot and set up for service.

#### 5.3.2 RELAY BOARD

The relay printed circuit board part number 11-0195 controls the three control outputs and the temperature resistor. Activated by a signal from the Receiver/Decoder board relays on the relay board close to provide voltage to the control output pins. Relay K1 Controls the Control 1 output. Relay K2 controls the Control 2 Output. Relay K3 controls the Control 3 output. Relay K4 controls the heater resistor. Control output relay activation can be monitored by the red LED's mounted on the top of the relay board sticking through the plastic board cover. The temperature relay can be monitored by the green LED on top of the relay board also sticking through the plastic board cover. This board is non field serviceable and must be replaced in the event of failure.

5.3.3. RECEIVER/DECODER:

The Receiver/Decoder Board is printed circuit board identified as C.I. part # 11-0255. The board compromises the complete receiver, decoder, and timer functions for the unit.

An effective method of determining condition of the receiver board may be accomplished by listening to the audio at the output jack identified in Figure K. A head set or suitable audio amplifier will reveal a slight pressure of noise which gives a general indication if the receiver is operative or inoperative. Depressing the red test button should cause a loud hum to occur in the headset and cause the timer and signal LED's to light. The timer light will extinguish after 5 seconds the signal will extinguish are test button in released. Absence of either of these indications represents probable receiver board failure.

The microprocessor on the receiver/decoder board controls the decoder, timer, disable functions, and temperature as explained below.

5.3.3.1 DECODER FUNCTION:

The Microprocessor counts the inputted clicks within a 5 second period from the first click and activates the corresponding relays to output to the proper control lines.

- 3 Clicks = 120vac out to Control Line 1
- 5 Clicks = 120vac out to Control Lines 1, and 2
- 7 Clicks = 120vac out to Control Lines 1, 2, and 3.

5.3.3.2 TIMER FUNCTION:

After the 5 second timer light goes out. The internal timer will start a 15-minute countdown. After 15 minutes the board will reset and open and Control Lines that were activated. The timer will reset to 15 minutes if another selection in made during the countdown period.

The Time out period come preset to 15 minutes but is adjustable in 15-minute periods up to 1 hour by adjusting dip switch setting on the Receiver/Decoder board. See chart below.

15 Minutes	1	X	O
	2	X	N

30 Minutes	1		X O
	2	X	N

45 Minutes	1	X	O
	2		X N

60 Minutes	1		X O
	2		X N

5.3.3.3 DISABLE FUNCTIONS:

**Remote Disable:** A short across these two terminals indicated by a red led next to the terminal block. Will disable the decoder of the microprocessor and out the unit in stand-bye mode. This is where you could attach a photo sensor or external switch to disable the unit.

**Decoder Disable Switch:** With this switch in the on position as indicated by a red led next to the switch, the unit will lock in on the last command given during the 5 second activation period. The unit will hold that command for the time out period and will not accept another command until after the time out period has ended.

Example: If the timer is set to 15 minutes and the decoder receives 7 clicks in the 5 second period the unit will close relays for Control 1, 2, and 3 and lock them on during the 15 minutes period.

5.3.3.4 TEMPERATURE FUNCTION:

The Microprocessor monitors a temperature IC mounted to the Receiver/Decoder PCB and activates a relay on the relay board when the temperature drops below 40F. This powers a heater resistor on the bottom of the chassis to prevent the unit from freezing. Temperature relay activation can be determined by the green LED on the relay board.

## 6.0 INSTALLATION:

The receiver-controller RC-1T5A is designed for all-weather outdoor unattended operation. The weather-tight case will repel the elements and no shelter is required.

Control and power lines should enter by means of the 1/2-inch conduit entry in the bottom of the unit. A maximum of five conductors is required to complete the installation.

The terminal block is clearly marked with neutral and 115V AC terminations. Attention to correct connection of the neutral is important. Failure to observe these instructions may damage the equipment and may result in the undesirable switching of the neutral instead of the "hot" side of the line.

For outdoor installation, the antenna is attached directly to the antenna mounting supplied on the top surface of the enclosure. For indoor installation, a remote ground-plane VHF antenna is supplied.

**FIG K**  
**MOUNTING PLAN, PICTORIAL**  
(Shown with PCB Cover Removed)

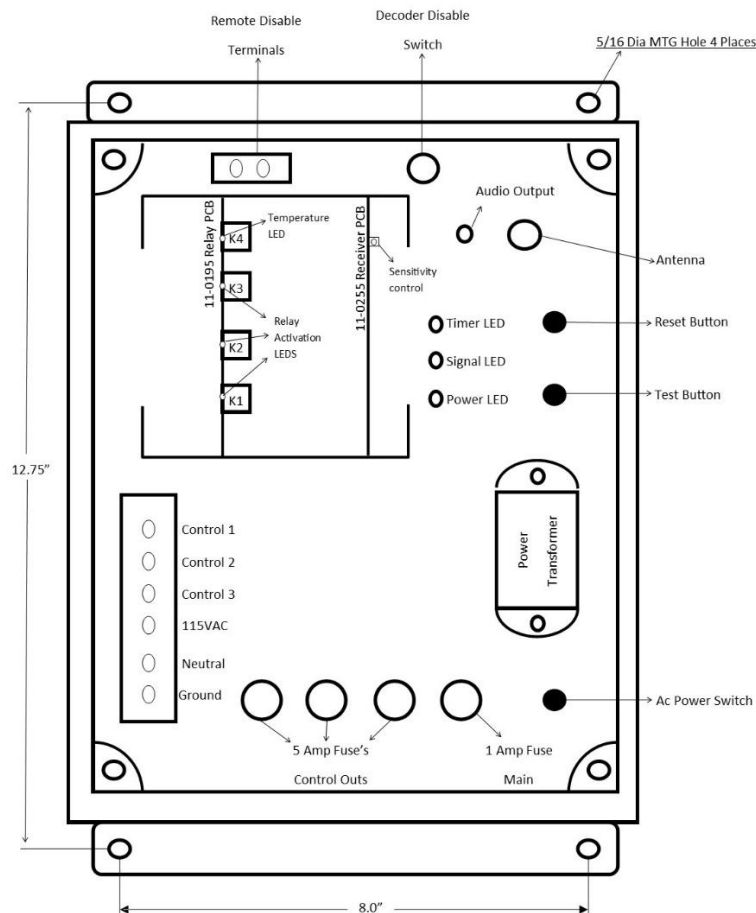

## 7.0 SPECIFICATIONS

<b>Output</b>	<b>10-amp relay contact fused at 5 amps</b>
<b>Input</b>	<b>120 VAC±20%, 50-60 HZ</b>
<b>Size</b>	<b>10"Wx 12" H x 5" D</b>
<b>Mounting</b>	<b>Any flat surface</b>
<b>Weight</b>	<b>Approximately 15 lbs</b>
<b>Temperature</b>	<b>-55 C to +55 C</b>
<b>Frequency</b>	<b>Within VHF range as specified by customer</b>
<b>Warranty</b>	<b>1 year from date of purchase</b>
<b>Antenna</b>	<b>VHF whip or remote antenna as required</b>

## 8.0 REPLACEMENT PARTS LIST

<b>Base Assembly</b>	<b>1</b>	<b>Control Industries No. 11-0233</b>
<b>Receiver Board</b>	<b>1</b>	<b>Control Industries No. 11-0255</b>
<b>Power Relay Board</b>	<b>1</b>	<b>Control Industries No. 11-0195</b>
<b>Fuse</b>	<b>3</b>	<b>LittleFuse MDL 5</b>
<b>Fuse</b>	<b>1</b>	<b>LittleFuse MDL 1</b>

## 9.0 Warranty Information:

**Control Industries INC.** Warranties that the equipment has been manufactured and will perform in accordance with applicable specifications and that any defect in design, materials, or workmanship which may occur during proper and normal use during a period of 1 year from date of installation or 2 years from date of shipment will be corrected by repair or replacement by the manufacturers f.o.b. factory.

In the event of failure contact:

**Control Industries INC**  
**419-800-0011**  
**Contact@controlindustriesinc.com**