



## ABRASIVE BELT COSTS TOO HIGH? SANDING QUALITY POOR?

**95% of Multi-Head Sanders Are Improperly Set-Up Which Results In:**

Belt Loading • Belt Burning • Streaking • Diminished Belt Life • Poor Quality

**Correct All These Issues with Proper Set-Up Using the New  
WIDEBELT SANDER SET-UP / DIAGNOSTIC DEVICE**

**With Digital  
Remote Indicator**

**\$695<sup>00</sup>**

Patent # 6,655,038



### This device allows you to easily:

- Set / Check relative height settings of contact drums, pinch rolls, and shoes throughout your entire machine
- Set / Check side to side height settings of contact drums, pinch rolls, and shoes
- Check contact drums, pinch rolls, and shoes for wear across face
- Check runout of contact drums



Optional custom carrying case available - \$150

This unit has a **5-1/4" overall height** and is equipped with a **heavy duty base** for solid, stable support and a **detachable 3-section handle** for easy positioning of the measuring head. The smoothly operating **spring loaded plunger** is attached to a **precision electronic sensor** providing **instantaneous response**. The electronically linked **LCD remote digital readout** head is connected by a long flexible 9' cord to allow **easy positioning** of the readout for **convenient viewing** by the operator. The digital readout is **easily switched to mm or inch units** and allows electronic zeroing for taking measurements at different locations and **making comparisons easy**.



Included with every unit is The Widebelt Sander Setup Guide Booklet giving full, detailed step by step process and data for determining correct sanding parameters.

This device is manufactured by Carter Products under license from SSC.

To order this product please call, fax or email Howard Grivna at the SSC office. Please provide the following information: your name, a phone number and time you can be reached and the product or products of interest. Products and services can be purchased using the credit cards listed below or by check. We are always happy and ready to provide further details about this product or service should you have any questions.

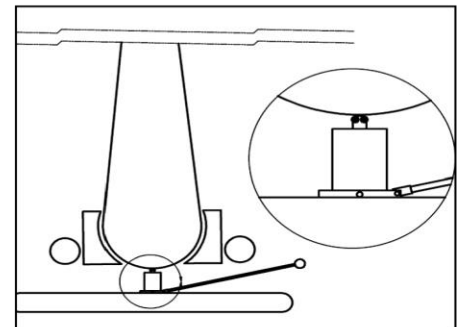

Summerhouse #10, 4655 Victoria St. N., Shoreview, MN 55126 Phone (651) 484-9758 Fax (651) 765-6057

E-Mail [hgrivna@sandingsystemsinc.com](mailto:hgrivna@sandingsystemsinc.com)