



2025 CORPORATE & CRESTING
PROGRAMME **GBP**

LOGO BALLS	3
<i>LOGO BALLS PRINTING SPECS</i>	6
<i>LOGO BALL ARTWORK SPECS AND FEES</i>	7
GENERAL CRESTING INFORMATION	8
GOLF BAGS	10
<i>TOUR BAGS</i>	11
<i>CART BAGS</i>	12
<i>STAND BAGS</i>	14
<i>BAGS CRESTING SPECS</i>	18
<i>BAGS ARTWORK SPECS AND FEES</i>	19
HEADWEAR	20
<i>HEADWEAR CRESTING SPECS</i>	25
<i>HEADWEAR ARTWORK SPECS AND FEES</i>	26
GLOVES	27
<i>GLOVES LOGO POSITION, ARTWORK SPECS AND FEES</i>	28
TRAVEL ACCESSORIES	30
<i>TRAVEL ACCESSORIES CRESTING SPECS</i>	33
<i>TRAVEL ACCESSORIES ARTWORK SPECS AND FEES</i>	34
ON-COURSE ACCESSORIES	35
<i>UMBRELLAS</i>	36
<i>UMBRELLAS ARTWORK SPECS AND FEES</i>	37
<i>TEES ARTWORK SPECS AND FEES</i>	38
CRESTING FEES RECAP	39



LOGO BALLS

TP5 / TP5X



N7680001
DOZEN



N7680201
DOZEN



N7680401
YELLOW DOZEN



N7680501
YELLOW DOZEN

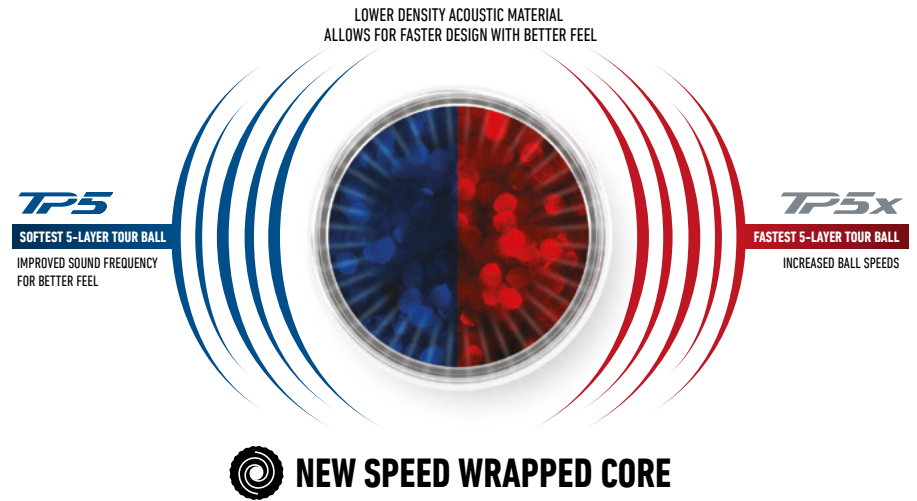

NEW 5-LAYER PROGRESSIVE CONSTRUCTION

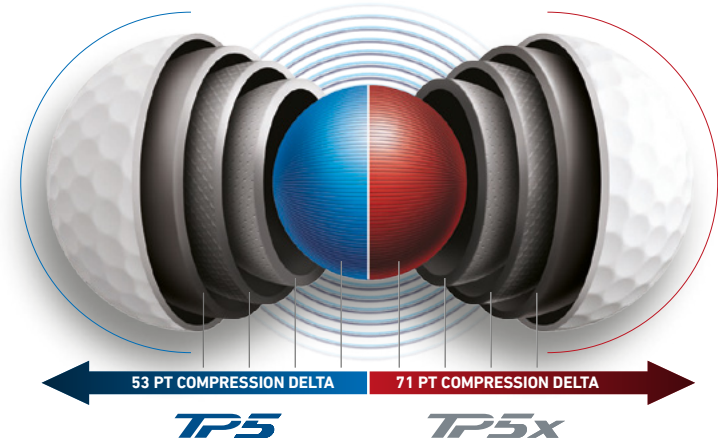

PRECISION LAYER DEVELOPMENT IS DESIGNED TO MAXIMIZE CORE THROUGH MANTLE LAYER STIFFNESS DELTAS GENERATING LOW DRIVER/LONG IRON SPIN AND HIGH WEDGE SPIN

MODEL	FEEL	BALL SPEED	IRON DISTANCE	WEDGE SPIN	LAUNCH	DIMPLE PATTERN	COVER MATERIAL	CONSTRUCTION
<i>TP5</i>	Softer	Faster	Longer	Higher	High	Seamless Tour Flight Dimple	Cast Urethane	5 Layers
<i>TP5x</i>	Soft	Fastest	Longest	High	Higher			

TOUR RESPONSE



M1002901

NEW

*EFFORTLESS COMPRESSION.
TOUR TECHNOLOGY.*

- High Spring Core
- Ultra-low 40 Compression Core
- SPEEDMANTLE™ with HFMq
- Soft, Tour Cast Urethane Cover



M1003001

NEW

DISTANCE +



M1003201

NEW

DESIGNED FOR SPEED

- Plus alignment aid, provides immediate feedback and easy alignment
- REACT™ Speed Core
- 342 Aerodynamic Dimple Pattern



M1003301

NEW

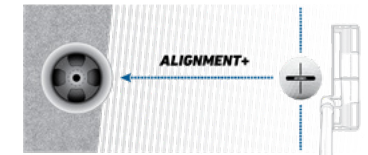

SPEEDSOFT



N2747801

OUR SOFTEST BALL

- NEW PWRCORE™, faster core materials developed for additional distance
- Larger core for easy compression and soft feel
- 322 extended flight dimple pattern, low drag aerodynamic dimple design

LOGO POSITION AND SIZES

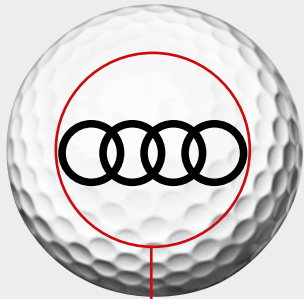

MAXIMUM
PRINT AREA FOR
CIRCULAR LOGOS
25mm DIAMETER

MAXIMUM
PRINT AREA FOR
SQUARED LOGOS
18.5mm x 18.5mm

DOUBLE POLE OPTION AVAILABLE

BESPOKE PACKAGING

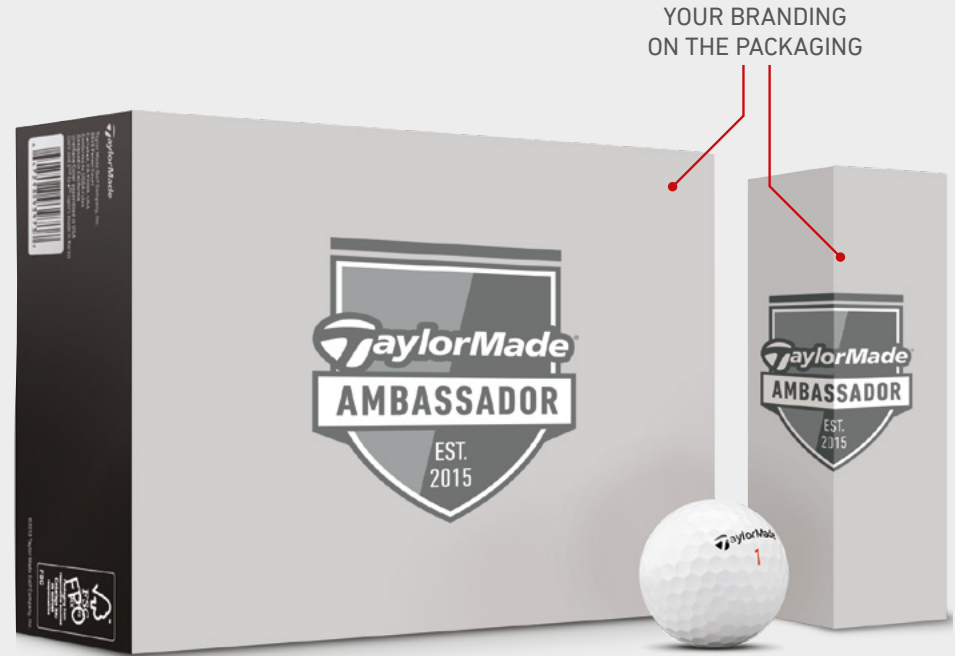

YOUR BRANDING
ON THE PACKAGING

MOQ FOR BOX IS 40 UNITS
MOQ FOR SLEEVES IS 100 UNITS

FULLY BESPOKE PACKAGING AVAILABLE ON ALL MODELS AT REQUEST & PRICING PER ORDER

WE RECOMMEND FILES TO BE SENT OVER IN **EPS/AI/PDF (VECTOR)** FORMAT FOR PROOFING. **JPEG, TIFF, PNG AND BMP** FILE FORMATS SUPPLIED MAY NEED TO BE RE-DRAWN.

LOGO BALL ORDERS

- Each order must be submitted with full instructions including colours required, single or double pole
- For each new artwork requested, a proof will be supplied for approval. Any amendments to the design of the logo requested after the proof has been supplied will be charged. Colour and size changes will not be charged.
- Only those products in catalogue marked as available for logo can have a logo applied
- All quantities must be divisible by 6 per ball type
- Coloured golf balls can only have a single colour (black) logo applied

DEFINITIONS

Re-draw – recreating a logo where the supplied logo is not of a high enough quality or no suitable logo can be supplied.

Amendment – changing a logo from what was originally submitted i.e changing the colour, layout and adding or removing part of the logo.

Setup fee – creation of a PDF artwork proof for approval.

LOGO BALL FEES	GBP
Single Pole Printing 24 dz +	FREE
Single Pole Printing 12-23 dz	£2.95
Double Pole Printing 24 dz +	£2.95
Double Pole Printing 12-23 dz	£5.90
Set Up Fee 24dz +	£15.00
Set Up Fee 12-23dz (1-2 col)	£39.00
Set Up Fee 12-23dz (3-5 col)	£20.00
Logo Re-draw	£5.00
Amendments including colour and text changes	£4.60
Personalisation	£4.60
Custom Packaging Set Up	£45.00
Custom Packaging Amendment	£5.00

PRINTING PRICES ARE PER DOZEN. SET UP FEES ARE PER ORDER.

Single Pole Printing – FREE, unless under 24dz. For 12-23dz, above printing charges apply. Orders under 12dz not accepted.

Double Pole Printing – First pole FREE, for second pole above printing charges apply for all orders. Orders under 12dz not accepted.

Set Up Fee – FREE for all orders over 24dz. For 12-23 dz above set up charges apply.

EMBROIDERY



SCREEN PRINT





FULL COLOUR

We match the colours of the logo supplied irrespective of the colour of the item being embroidered.



SELF COLOUR

We match the thread colour to the item being embroidered.



COLOUR CO-ORD

We embroider using colours from or within the item being embroidered, we can match to trims and existing branding.



TONAL

We use thread colours two shades lighter or darker than the item being embroidered.



CONTRAST

We use opposing colours of the item being embroidered. Dark threads on light garments and light threads on dark garments.

PLEASE NOTE:

EACH EMBROIDERY ORDER MUST BE SUBMITTED WITH **FULL INSTRUCTIONS** TO INCLUDE LOGO POSITION, LOGO SIZE AND COLOURS REQUIRED.
 FOR EACH NEW ARTWORK DESIGN, A **PROOF WILL BE SUPPLIED FOR APPROVAL** – THE ORDER WILL ONLY BE PROGRESSED ONCE APPROVAL IS RECEIVED.
 ANY **AMENDMENTS** TO THE SUBMITTED LOGO ONCE THE FIRST PROOF HAS BEEN CREATED **MAY BE CHARGEABLE** – THIS INCLUDES A COLOUR CHANGE, SIZE CHANGE ETC.
 ONLY THOSE **PRODUCTS IN CATALOGUE** MARKED AS AVAILABLE FOR CRESTING CAN BE EMBROIDERED/HAVE A LOGO APPLIED.



GOLF BAGS

TOUR STAFF BAG

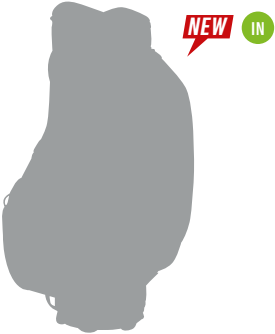

N3846801
DRIVER

CUSTOM

EMBROIDERY
FRONT PANEL

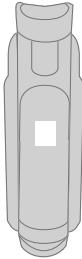

TOUR STAND BAG



N3854601
TOUR STAND

CUSTOM

EMBROIDERY
BALL POCKET

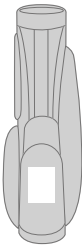

DEN CADDIE



N6545601
WHITE/BLACK

CUSTOM

EMBROIDERY
FRONT POCKET



CART LITE



N2642101
BLACK



N2642701
GREY



N3827501
CORAL



N3827701
LIGHT BLUE



N3827801
NAVY/GREY

CUSTOM

EMBROIDERY
BALL POCKET

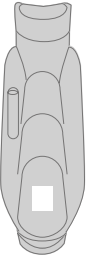

STORM DRY



V9782301
BLACK/GREY/WHITE



V9782401
NAVY/BLUE



V9782601
DARK GREY/LIGHT GREY



V9716801
BLACK/WHITE/RED



V9782501
RED/BLACK

CUSTOM

HEAT TRANSFER
BALL POCKET

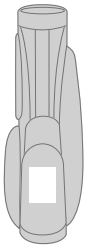

DELUXE CART



V9716301
BLACK/RED



V9781601
BLACK/BLUE



V9781701
BLACK/GREY



V9773401
NAVY/WHITE



V9773501
CHARCOAL

CUSTOM

EMBROIDERY
BALL POCKET

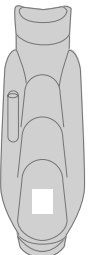

PRO CART



IN

V9736501
ROYAL



IN

V9736701
NAVY/RED



IN

V9736901
CHARCOAL



NEW IN

N2631401
BLACK



NEW IN

V9736401
BLACK/BLUE

CUSTOM

EMBROIDERY
BALL POCKET

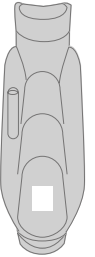

WAHINE



NEW IN

N3811601
NAVY/GREY*



NEW IN

N3811701
GREY/WHITE*

CUSTOM

EMBROIDERY
BALL POCKET

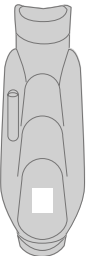

*1 INCH SHORTER THAN OTHER COLOURWAYS

FLEXTECH CROSSOVER



IN

N2657801
BLACK



IN

N2658101
GREY



NEW APR

N3835501
CORAL/LIGHT BLUE



NEW APR

N3835601
HERITAGE ICON



NEW FEB

N3861301
SCRIPT ICON

CUSTOM

EMBROIDERY
BALL POCKET

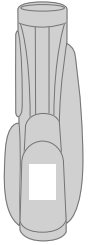

FLEXTECH



IN

N2647801
NAVY

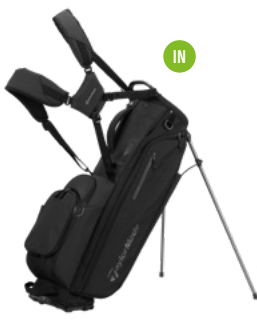

IN

N2685501
BLACK



NEW IN

N3830901
GREY/NAVY



NEW APR

N3830501
CORAL/NAVY



NEW APR

N3831001
HERITAGE ICON



NEW FEB

N3831101
SCRIPT ICON

CUSTOM

EMBROIDERY
BALL POCKET

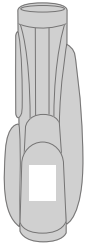

FLEXTECH CARRY



IN

N2650901
BLACK



IN

N2651001
NAVY



IN

N2651101
GREY



NEW APR

N3832401
LIGHT BLUE/CORAL



NEW APR

N3832501
HERITAGE ICON



NEW FEB

N3832601
SCRIPT ICON

CUSTOM

EMBROIDERY
BALL POCKET

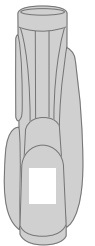

FLEXTECH CARRY PREMIUM



N2655701
BLACK

N2656001
NAVY

N3833501
LIGHT BLUE

N3834001
HERITAGE ICON

CUSTOM

EMBROIDERY
BALL POCKET

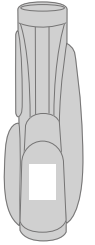

FLEXTECH SUPERLITE



N2664901
BLACK

N2665101
GREY

N2665201
NAVY

N3837501
LIGHT BLUE

N3837701
CORAL/NAVY

CUSTOM

EMBROIDERY
BALL POCKET

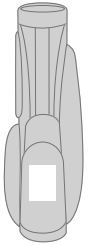

FLEXTECH WATERPROOF



V9738001
BLACK

V9738101
GUNMETAL

V9738201
NAVY

CUSTOM

HEAT TRANSFER
BALL POCKET

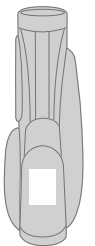

PRO STAND



IN

V9737301
ROYAL



IN

V9737501
NAVY/RED



IN

V9737701
CHARCOAL



NEW **IN**

N2631701
BLACK



NEW **IN**

V9737201
BLACK/BLUE

CUSTOM

EMBROIDERY
BALL POCKET

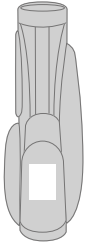

WAHINE STAND



NEW **IN**

N3811801
NAVY/GREY

CUSTOM

EMBROIDERY
BALL POCKET

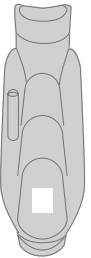

*1 INCH SHORTER THAN OTHER COLOURWAYS

CUSTOM FLEXTECH



CUSTOM
EMBROIDERY
BALL & APPAREL
POCKETS

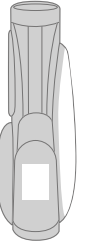

CUSTOM FLEXTECH CARRY



CUSTOM
EMBROIDERY
BALL & APPAREL
POCKETS

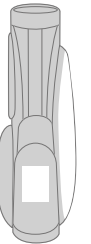

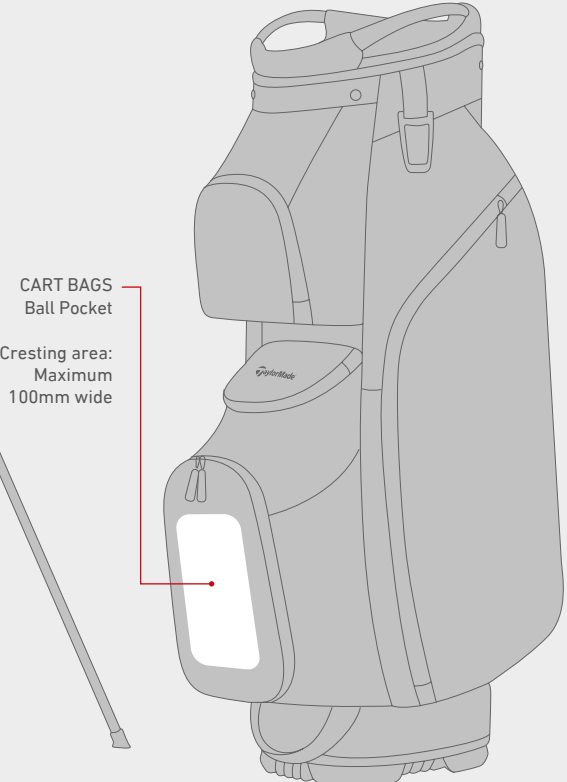
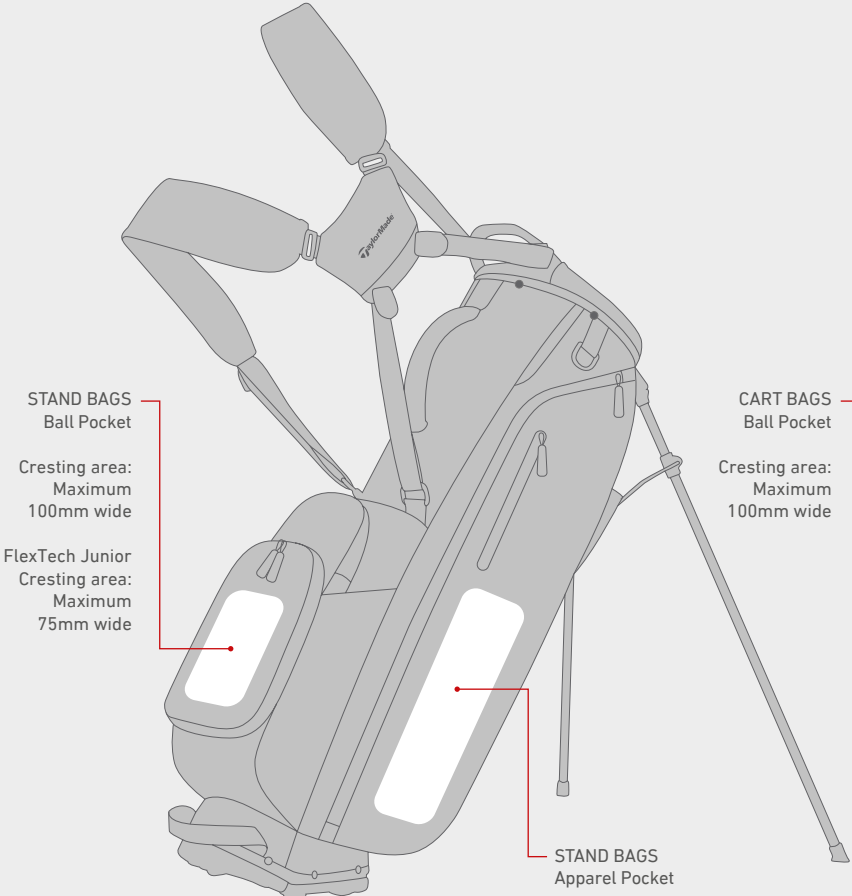

Maximum cresting area:
250mm in width and
50mm in height

Screen print only.

WE RECOMMEND FILES TO BE SENT OVER IN **EPS/AI/PDF** (VECTOR) FORMAT FOR PROOFING. **JPEG, TIFF, PNG AND BMP** FILE FORMATS SUPPLIED WILL NEED TO BE RE-DRAWN.

EMBROIDERY ORDERS

- Each order must be submitted with full instructions including logo colour and positioning. For any orders where colours or positions are not specified, default instructions will be applied automatically.
- For each new artwork requested, a proof will be supplied for approval. Any additional amendments requested after this initial proof is created, will be charged. This includes changes to colour, size and design of logo.

DEFINITIONS

Amendment – changing a logo from what was originally submitted i.e changing the colour, layout and adding or removing part of the logo.

Setup fee – creation of a PDF artwork proof for approval.

ARTWORK SET UP FEE (PER LOGO)	GBP
Embroidery Set Up	£40.00
Screen Print Set Up	£21.50
Amendments & Colour Changes	£15.00
Proof for Text on any Bag	FREE

EMBROIDERY FEES (PER LOGO)	MOQ	GBP
Golf Bags - Logo	6	£4.50
Golf Bags - Name only	1	£4.50
Staff Bags - Logo or Name only	1	£14.75
Staff Bags - Name + Logo	1	£29.50

SCREEN PRINT (PER LOGO)	MOQ	GBP
Golf Bag	6	£13.50



HEADWEAR

EVERGREEN RADAR

NEW IN



WHITE
R - N2678918
XS - N2678914*

NEW IN



BLACK
R - N2679018
XS - N2679014*

NEW IN



NAVY
R - N2679118
XS - N2679114*

NEW IN



GREY
R - N2679218
XS - N2679214*

NEW IN



ROYAL
R - N2679318
XS - N2679314*

NEW FEB



GREEN
R - N2679418

NEW FEB



LAVENDAR
R - N3823518

NEW FEB



AQUA
R - N3823618

NEW FEB



CORAL
R - N3823818

*SIZE XS RECOMMENDED FOR JUNIORS AND WOMEN

CUSTOM

EMBROIDERY
SIDE PANEL



CUSTOM

EMBROIDERY
SIDE PANEL



SUNSET GOLF

NEW IN



WHITE
N2681918

NEW IN



BLACK
N2682018

NEW IN



PINK
N2682318

NEW IN



OLIVE
N2682418

NEW IN



NAVY
N2682118

NEW FEB



COBALT
N3825618

NEW FEB



AQUA
N3825718

CUSTOM

EMBROIDERY
SIDE PANEL



CUSTOM

EMBROIDERY
SIDE PANEL



LS GOLF LOGO



WHITE N7883201 BLACK N7883301 NAVY N7883401 RED N7883501 CHARCOAL N7883601 ROYAL N7883701

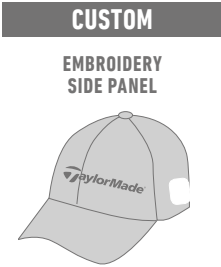

LS SCRIPT SEEKER



WHITE N8939401 BLACK V9733801 NAVY N8939501 BLUE GREY N8939601 CHARCOAL N8939801 PINK N8939701



TM PERFORMANCE TRADITION



NAVY M7126101 GREY M7126001 BLACK M7125901 RED M7126201 WHITE M7126301 GRAPHITE M7126401

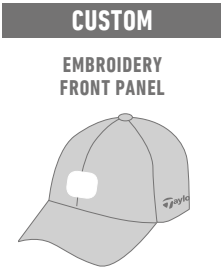

TM STORM BUCKET HAT



BLACK
S/M N7764417
L/XL N7764421

GREY
S/M N7764517
L/XL N7764521

CUSTOM

FULL COLOUR
SCREEN PRINT



TM STORM HAT



GREY
N7746501

BLACK
N7746401

CUSTOM

FULL COLOUR
SCREEN PRINT



BOBBLE BEANIE



BLACK
V9763101

NAVY
V9781001

RED
V9781101

CHARCOAL HEATHER
V9781201

CUSTOM

EMBROIDERY
ON BACK

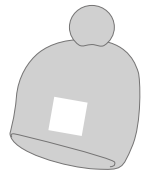

BEANIE



BLACK
V9765201

NAVY
V9781301

CHARCOAL HEATHER
V9781401

CUSTOM

EMBROIDERY
ON BACK

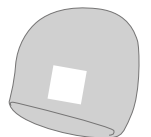

WOMEN'S TOUR



CHARCOAL
N7758501

WHITE
N7758601

BLACK
N7758701

NAVY
N7758901

CUSTOM

EMBROIDERY
SIDE PANEL



WOMEN'S TM SCRIPT



BLACK
N8939901

WHITE/PINK
N8940001

BLACK/AQUA
N8940101

WHITE
V9733901

CUSTOM

EMBROIDERY
SIDE PANEL



WOMEN'S PERFORMANCE CUSTOM



LIGHT BLUE
M7126801

PURPLE
M7126601

WHITE
M7126701

GREY
M7126501

CUSTOM

EMBROIDERY
SIDE PANEL



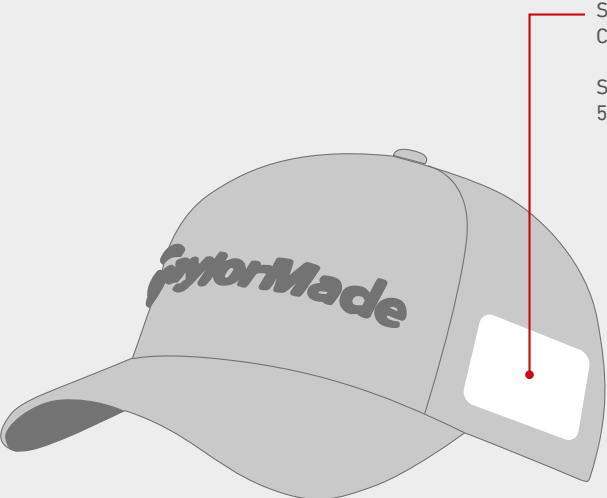

SIDE PANEL CRESTING.
SIZE: Maximum 50mm wide

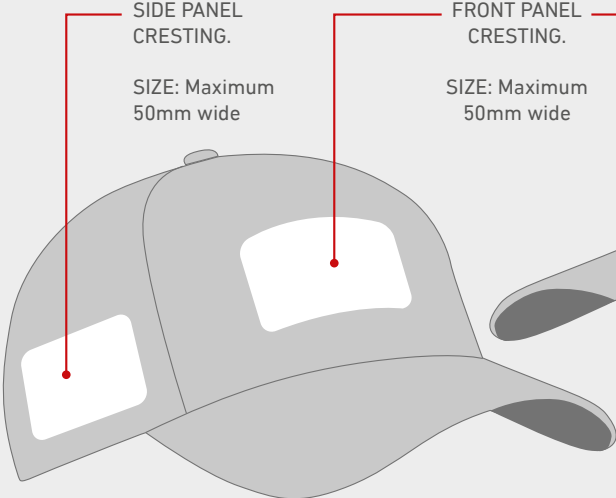

SIDE PANEL CRESTING.
SIZE: Maximum 50mm wide

FRONT PANEL CRESTING.
SIZE: Maximum 50mm wide

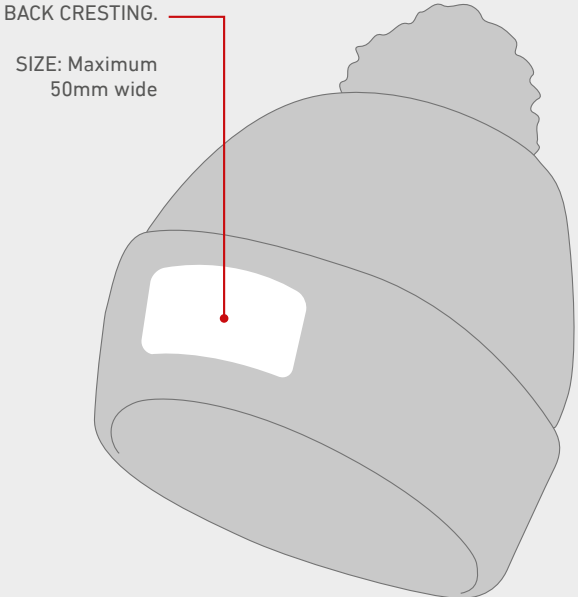
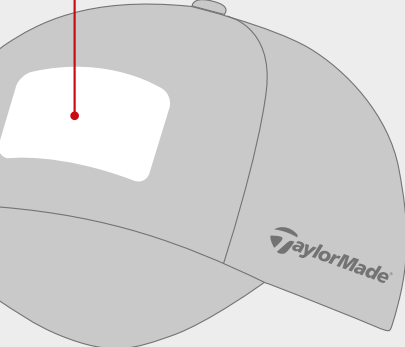

BACK CRESTING.
SIZE: Maximum 50mm wide

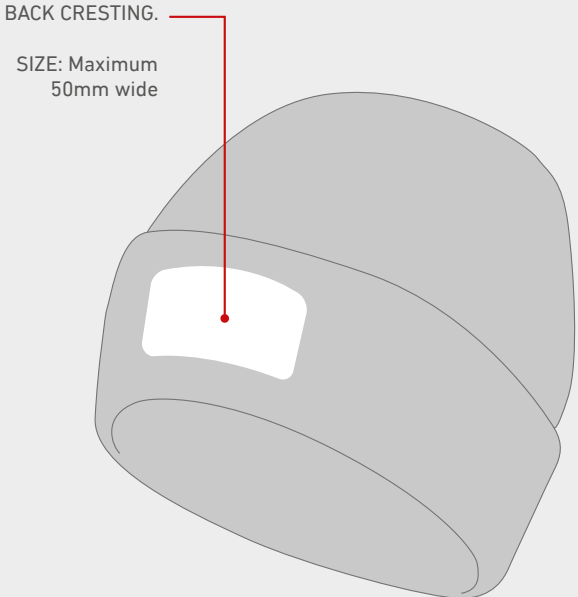

BACK CRESTING.
SIZE: Maximum 50mm wide

WE RECOMMEND FILES TO BE SENT OVER IN **EPS/AI/PDF** (VECTOR) FORMAT FOR PROOFING. **JPEG, TIFF, PNG AND BMP** FILE FORMATS SUPPLIED WILL NEED TO BE RE-DRAWN.

EMBROIDERY ORDERS

- Each order must be submitted with full instructions including logo colour and positioning. For any orders where colours or positions are not specified, default instructions will be applied automatically.
- For each new artwork requested, a proof will be supplied for approval. Any additional amendments requested after this initial proof is created, will be charged. This includes changes to colour, size and design of logo.

DEFINITIONS

Re-draw – recreating a logo where the supplied logo is not of a high enough quality or no suitable logo can be supplied.

Amendment – changing a logo from what was originally submitted i.e changing the colour, layout and adding or removing part of the logo.

Setup fee – creation of a PDF artwork proof for approval.

ARTWORK SET UP FEE (PER LOGO)	GBP
Embroidery Set Up incl. Re-draw	£40.00
Screen Print Set Up	£21.50
Amendments & Colour Changes	£15.00
Proof for Text on any Bag	FREE

EMBROIDERY FEES (PER LOGO)	MOQ	GBP
Golf Hats	6	£2.90

SCREEN PRINT (PER LOGO)	MOQ	GBP
Storm Headwear	6	£2.90



GLOVES

TOUR PREFERRED CUSTOM



NEW **IN**

MEN'S

LH/S	N3866919
LH/M	N3866920
LH/ML	N3866921
LH/L	N3866922
LH/XL	N3866923
RH/S	N3867019
RH/M	N3867020
RH/ML	N3867021
RH/L	N3867022

- AAA Cabretta Soft Tech™ Leather
- Engineered perforation for breathability
- Contoured fit wrist lining
- Stretch fit tab adjustment
- Moisture-wicking wristband
- Antimicrobial



STRATUS SOFT CUSTOM - MEN'S



IN

MEN'S

LH/S	N7845319
LH/M	N7845320
LH/ML	N7845321
LH/L	N7845322
LH/XL	N7845323
RH/S	N7845419
RH/M	N7845420
RH/ML	N7845421
RH/L	N7845422

- Genuine leather
- Superior durability, treated, wear-resistant leather
- Soft Feel, thin, all-leather construction
- Enhanced breathability
- Strategically placed micro perforations to optimize airflow for any climate
- Ultimate flexibility
- 4-way stretch material and genuine leather construction, delivers superior comfort
- Superior fit
- Contoured fit wrist band with moisture wicking properties
- Velcro closure includes magnetic section to place bespoke ball marker



STRATUS TECH CUSTOM - MEN'S



IN

MENS

LH/S	M7113319
LH/M	M7113320
LH/ML	M7113321
LH/L	M7113322
LH/XL	M7113323
RH/S	M7113419
RH/M	M7113420
RH/ML	M7113421
RH/L	M7113422

WOMENS

LH/S	N6407417
LH/M	N6407418
LH/L	N6407419
RH/S	N6407517
RH/M	N6407518
RH/L	N6407519

- Synthetic and leather combination
- Hypertec synthetic material
- Durable performance
- Wear resistant combination of hypertec and leather
- Sweat and humidity resistant
- Hypertec material helps maintain a consistent grip in hot and humid conditions
- Enhanced breathability
- Strategically placed micro perforations to optimize breathability for any climate
- Ultimate flexibility with a 4-way stretch material with leather and hypertec construction,
- Stratus Tech delivers comfort, fit, and feel for your game
- Delivery: 14/01/2019



TOUR PREFERRED MOTION CUSTOM - WOMEN'S



NEW **IN**

WOMEN'S

LH/S	N3870017
LH/M	N3870018
LH/L	N3870019
RH/S	N3870117
RH/M	N3870118
RH/L	N3870119

- AAA Cabretta Leather
- Strategic perforation for breathability
- Stretch zones on back of hand and fingers for optimum range of motion
- Contoured fit wrist lining
- Stretch fit tab adjustment
- 4-way nylon stretch insert
- Moisture-wicking wristband
- Antimicrobial



WE RECOMMEND FILES TO BE SENT OVER IN **EPS/AI/PDF (VECTOR)** FORMAT FOR PROOFING. **JPEG, TIFF, PNG AND BMP** FILE FORMATS SUPPLIED WILL NEED TO BE RE-DRAWN.

DEFINITIONS

Amendment – changing a logo from what was originally submitted i.e changing the layout and adding or removing part of the logo.
Setup fee – creation of a PDF artwork proof for approval.

ARTWORK SET UP FEE (PER LOGO)	GBP
Glove	£12.00
Amendments including colour and text changes	£5.00

GLOVES	MOQ	GBP
Ball Marker	12	£1.50
Custom Packaging Set Up		£45.00
Custom Packaging Amendment		£5.00



**TRAVEL
ACCESSORIES**

PERFORMANCE TRAVEL COVER



IN

- Full wrap around zipper for easy access to golf bag
- Durable drizzle-effect fabric construction
- 360 top and side padding for maximum club protection
- Interior strap stabilizes bag during travel
- Heavy duty anti-burst strapping system
- Durable, smooth rolling In-Line skate wheels
- Durable, skid resistant PVC base material for added durability
- High density printing TaylorMade logo
- 54" x 15" x 14"

CUSTOM

EMBROIDERY FRONT PANEL

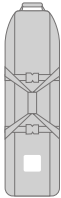

N8946201
BLACK

PERFORMANCE MEDIUM DUFFLE BAG



IN

- 4 total pockets, featuring:
 - Main storage compartment
 - 2 External accessory pockets
- Padded adjustable carry strap
- Double grab handles
- High density printed TaylorMade logo
- Custom embroidery front pocket
- 900D Construction
- 22" x 12" x 12"

CUSTOM

EMBROIDERY SIDE PANEL

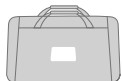

N8947701
BLACK

PERFORMANCE BACKPACK



IN

- 6 total pockets, featuring;
- Laptop and tablet sleeve
- Velour lined valuables pocket
- 2 x Water bottle mesh holder
- Organized compartment: key hook, name card holder, pen holder
- Top carry handle
- Adjustable mesh padded backpack straps
- Padded back panel for comfort
- High density printed TaylorMade logo
- 18" x 12" x 7"

CUSTOM

EMBROIDERY FRONT POCKET



N8947501
BLACK

PERFORMANCE PRACTICE BALL BAG



IN

- 7.5" Plastic base for strength and durability
- Padded Double grab handles
- High density printed TaylorMade logo
- 13" x 12" x 4"

CUSTOM

EMBROIDERY
FRONT PANEL



N8949601
BLACK

PERFORMANCE SHOE BAG



IN

- Roomy space fits most shoe sized
- Spike and wrench pocket
- Vent-hole provide moisture ventilation
- High density printed TaylorMade logo
- 15" x 11" x 5"

CUSTOM

EMBROIDERY
FRONT POCKET



N8947901
BLACK

PERFORMANCE VALUABLES POUCH



IN

- Drawstring closure with extra clip
- Internal fur lined zipper pocket
- High density printed TaylorMade logo
- 7.5" x 6" x 1.5"

CUSTOM

EMBROIDERY
FRONT PANEL



N8949501
BLACK

MICROFIBER CART TOWEL

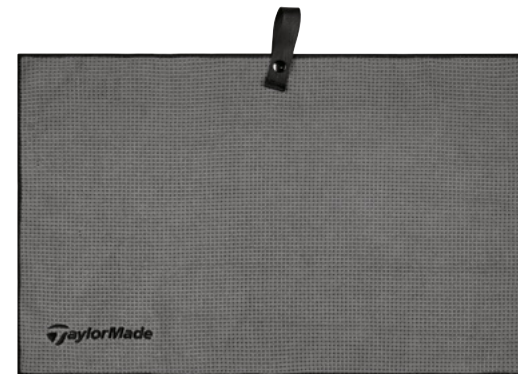

IN

- Soft and absorbent waffle-weave construction
- Nylon webbing bag loop
- TaylorMade embroidery
- 15" x 24"
- 85% polyester, 15% polyamide

CUSTOM

EMBROIDERY
BOTTOM RIGHT

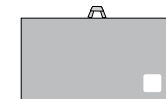

MAXIMUM 100mm
WIDE

B1599601
GREY

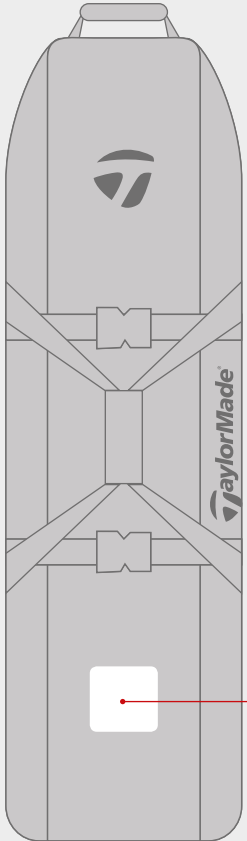

TRAVEL COVER
Centre front panel
Cresting area:
Maximum
100mm wide

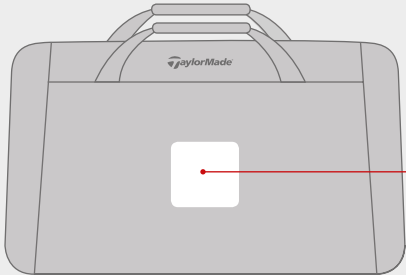

DUFFLE BAG
Side panels
Cresting area:
Maximum
100mm wide

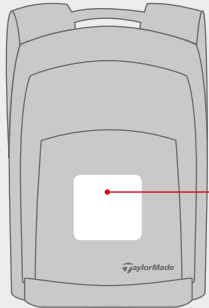

BACKPACK
Centre front
pocket
Cresting area:
Maximum
100mm wide

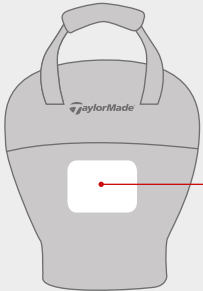

PRACTICE
BALL BAG
Centre front
panel
Cresting area:
Maximum
75mm wide

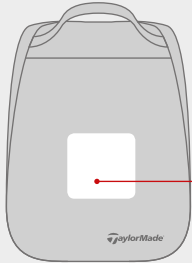

SHOE BAG
Centre front
pocket
Cresting area:
Maximum
100mm wide

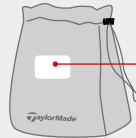

VALUABLES
POUCH
Centre front
panel
Cresting area:
Maximum
50mm wide

WE RECOMMEND FILES TO BE SENT OVER IN **EPS/AI/PDF** (VECTOR) FORMAT FOR PROOFING. **JPEG, TIFF, PNG AND BMP** FILE FORMATS SUPPLIED WILL NEED TO BE RE-DRAWN.

EMBROIDERY ORDERS

- Each order must be submitted with full instructions including logo colour and positioning. For any orders where colours or positions are not specified, default instructions will be applied automatically.
- For each new artwork requested, a proof will be supplied for approval. Any additional amendments requested after this initial proof is created, will be charged. This includes changes to colour, size and design of logo.

DEFINITIONS

Amendment – changing a logo from what was originally submitted i.e changing the colour, layout and adding or removing part of the logo.

Setup fee – creation of a PDF artwork proof for approval.

ARTWORK SET UP FEE (PER LOGO)	GBP
Embroidery Set Up	£40.00
Amendments & Colour Changes	£15.00
Proof for Text on any Bag	FREE

EMBROIDERY FEES (PER LOGO)	MOQ	GBP
Travel accs	3	£4.50
Towel	3	£3.00



***ON COURSE
ACCESSORIES***

DOUBLE CANOPY UMBRELLA 64"

NEW **IN**



- 64-inch auto-open Vented Canopy
- Heavy duty FRP fiberglass frame for superior durability
- Anti-Inversion Cable can withstand gusts up to 75 mph!
- Ergonomic TMG custom handle provides added comfort
- Textured fiberglass shaft & fiberglass frame in pop color
- Rubber tip ferrule
- Sleeve



N3845601
BLACK/WHITE/RED

DOUBLE CANOPY UMBRELLA 68"

NEW **IN**



- 68" Manual Vented Vortex Canopy
- Heavy duty FRP fiberglass frame with anti-inversion struts
- TPR Tabs with custom TM logo
- Elastic Straps to help prevent inversion
- Vortex Vented Canopy - engineered to resist windy conditions
- Ergonomic TMG custom V3 handle provides added comfort
- Rubber tip ferrule

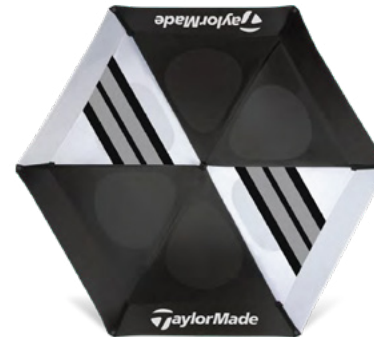

N3845701
BLACK/WHITE/RED

UMBRELLAS - LOGO POSITION AND SIZES

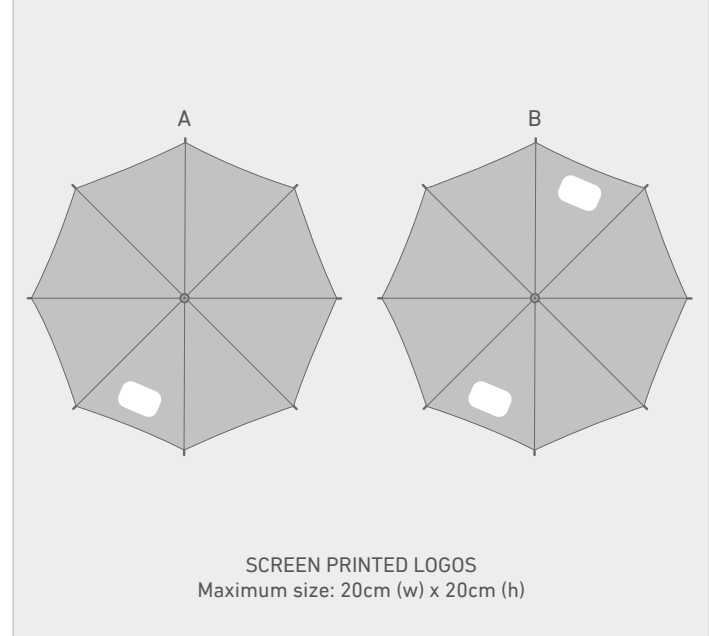

WE RECOMMEND FILES TO BE SENT OVER IN **EPS/AI/PDF** (VECTOR) FORMAT FOR PROOFING. **JPEG, TIFF, PNG AND BMP** FILE FORMATS SUPPLIED WILL NEED TO BE RE-DRAWN.

EMBROIDERY ORDERS

- Each order must be submitted with full instructions including logo colour and positioning. For any orders where colours or positions are not specified, default instructions will be applied automatically.
- For each new artwork requested, a proof will be supplied for approval. Any additional amendments requested after this initial proof is created, will be charged. This includes changes to colour, size and design of logo.

DEFINITIONS

Re-draw – recreating a logo where the supplied logo is not of a high enough quality or no suitable logo can be supplied.

Amendment – changing a logo from what was originally submitted i.e changing the colour, layout and adding or removing part of the logo.

Setup fee – creation of a PDF artwork proof for approval.

**New 2025 Umbrellas can only be customised on the two white panels.*

ARTWORK SET UP FEE (PER LOGO)	GBP
Umbrella	£12.00
Amendments including colour and text changes	£5.00

UMBRELLAS	MOQ	GBP
1 Panels	6	£3.00
2 Panels	6	£6.00

CORPORATE TEES



N2128401

- White, length 70mm (1,000 loose tees per box)
- T-Bug logo is in cup
- Print on side only
- 1 or 2 colour print
- Tees can be bagged up in 20's, 30's, 50's & 100's at no extra cost

ARTWORK SET UP FEE (PER LOGO)	GBP
Tee Set Up 1 colour	£11.50
Tee Set Up 2 colour	£22.00
Amendments including colour and text changes	£5.00

TEES	MOQ	GBP
1 Colour	1,000	£23.00
2 Colour	1,000	£31.00
Tee packaging charge per 1,000	(1000) Multiples in 20, 25, 50, 100	£17.00

WE RECOMMEND FILES TO BE SENT OVER IN EPS/AI/PDF (VECTOR) FORMAT. JPEG, TIFF, PNG AND BMP FILE FORMATS SUPPLIED WILL NEED TO BE RE-DRAWN.

EMBROIDERY ORDERS

- Each order must be submitted with full instructions including logo colour and positioning. For any orders where colours or positions are not specified, default instructions will be applied automatically.
- For each new artwork requested, a proof will be supplied for approval. Any additional amendments requested after this initial proof is created, will be charged. This includes changes to colour, size and design of logo.

DEFINITIONS

Amendment – changing a logo from what was originally submitted i.e changing the layout and adding or removing part of the logo.
Setup fee – creation of a PDF artwork proof for approval.

ARTWORK SET UP FEE (PER LOGO)	GBP
Embroidery Set Up incl. Re-draw	£40.00
Amendments & Colour Changes - Embroidery	£15.00
Amendments & Colour Changes - Print	£5.00
Swatch	FREE
Umbrella	£12.00
Glove	£12.00
Screen Print Set Up	£21.50
Tee Set Up 1 colour	£11.50
Tee Set Up 2 colours	£22.00

CRESTING FEES (PER LOGO)	MOQ	GBP
Golf Hats	6	£2.90
Travel accs	3	£4.50
Towels	3	£3.00
Golf Bags - Logo Only	6	£4.50
Golf Bags - Name only	1	£4.50
Staff Bags - Logo or Name only	1	£14.75
Staff Bags - Name + Logo	1	£29.50

LOGO BALL FEES	GBP
Single Pole Printing 24 dz +	FREE
Single Pole Printing 12-23 dz	£2.95
Double Pole Printing 24 dz +	£2.95
Double Pole Printing 12-23 dz	£5.90
Set Up Fee 24dz +	£15.00
Set Up Fee 12-23dz (1-2 col)	£39.00
Set Up Fee 12-23dz (3-5 col)	£20.00
Logo Re-draw	£5.00
Amendments including colour and text changes	£4.60
Personalisation	£4.60
Custom Packaging Set Up	£45.00
Custom Packaging Amendment	£5.00

PRINTING PRICES ARE PER DOZEN. SET UP FEES ARE PER ORDER.

Single Pole Printing - FREE, unless under 24dz. For 12-23dz, above printing charges apply. Orders under 12dz not accepted.

Double Pole Printing - First pole FREE, for second pole above printing charges apply for all orders. Orders under 12dz not accepted.

Set Up Fee - FREE for all orders over 24dz. For 12-23 dz above set up charges apply.

SCREEN PRINT (PER LOGO)	MOQ	GBP
Golf Bag	6	£13.50
Storm Headwear	6	£2.90

CRESTING FEES (PER LOGO)	MOQ	GBP
1 Panel	6	£3.00
2 Panels	6	£6.00

CRESTING FEES (PER LOGO)	MOQ	GBP
Ball Marker	12	£1.50

CRESTING FEES (PER LOGO)	MOQ	GBP
1 Colour	1000	£23.00
2 Colour	1000	£31.00
Tee Packaging charge per 1,000	(1000) Multiples in 20, 25, 50, 100	£17.00



General Terms of Trade

Any order for goods to which this catalogue relates is subject to the TaylorMade Golf Limited policies and general terms and conditions in effect at the time such order is placed. Copies of the policy are available to any authorised TaylorMade retailer upon request.

© 2024 TaylorMade Golf Limited. TaylorMade Golf Limited is a company organised under the laws of England (Company Number 1424575) with a registered address of TaylorMade Court, Viabes Business Park, Jays Close, Basingstoke, Hampshire, RG22 4BS.