

6969-J

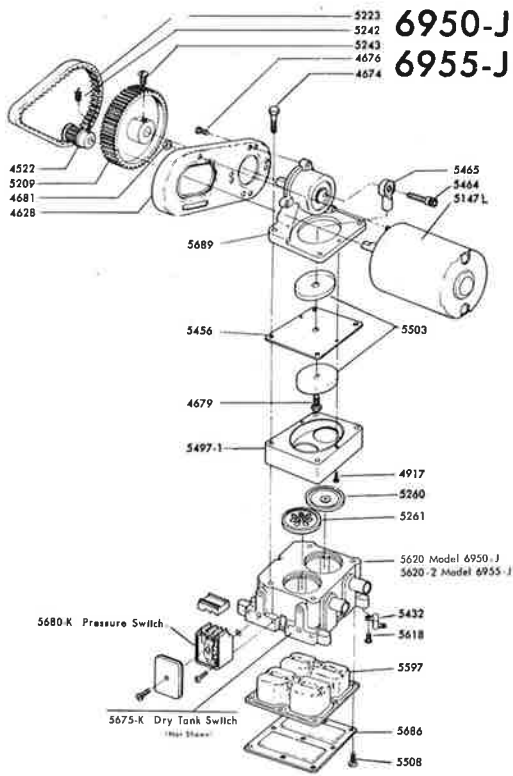
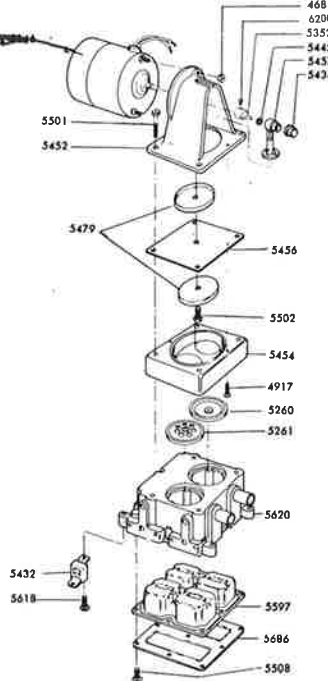

PUMP PARTS LIST

CAUTION ALL REPLACEMENT PARTS MUST BE SAME AS ORIGINAL EQUIPMENT.

Part No.	Description	Price
4522	Small Pulley	\$ 2.50
4523	Large Pulley	3.25
4543	Belt	4.25
4628	Motor Mount D. C.	1.95
4674	Tie-Down Screw	.15
4676	Motor Bracket Screw	.15
4677	Screw	.25
4679	Diaphragm Screw	.50
4681	Motor Nut	.10
4684	Screw	.10
4917	Screw	.10
5146	Motor (Kit #202) 12-volt	14.50
	32-volt	19.00
5147-L	Motor (Kit #208) 12-volt	17.00
	32-volt	19.00
5147-S	Motor (Kit #201) 12-volt	17.00
	32-volt	19.00
5148	Motor (Kit #200) 12-volt	17.00
	32-volt	19.00
5196	Diaphragm (Kit #16)	3.50
5209	Pulley	3.50
5212	Diaphragm Plate	.60
5223	Belt	4.25
5242	Screw	.10
5243	Screw	.10
5256	Brace	.25
5260	Intake Valve Assy.	
5261	Discharge Valve Assy. (Kit #4)	2.25
5352	Eccentric	1.50
5432	Vibration Pad	.35
5434	Connection Rod Cover	.25
5445	Thrust Washer	.10
5452	Motor Mount	3.00
5454	Diaphragm Ring	4.50
5456	Diaphragm (Kit #15)	4.00
5457	Connecting Rod	1.90
5464	Connecting Rod Screw	.30
5465	Connecting Rod Assembly	6.00
5479	Diaphragm Plate	.50
5173-1	Diaphragm Ring	3.25
5497-1	Diaphragm Ring	3.00
5501	Tie-down Screw	.15
5502	Diaphragm Screw	.15
5503	Diaphragm Plate	.50
5508	Screw	.10
5597	Pulsation Dampener	2.50
5618	Screw	.10
5620	Base Assembly Model 6950-J	10.50
5620-2	Base Assembly Model 6955-J	10.50
5623	Bottom Cap	3.75

6800-J
6850-J

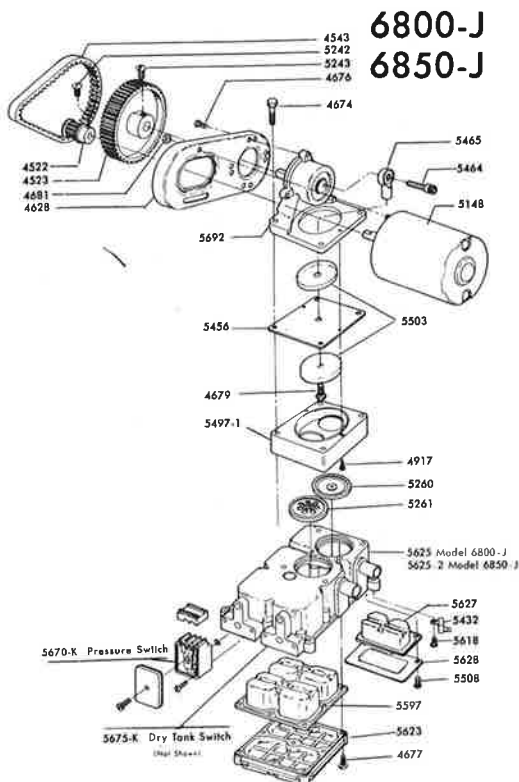

6900-J

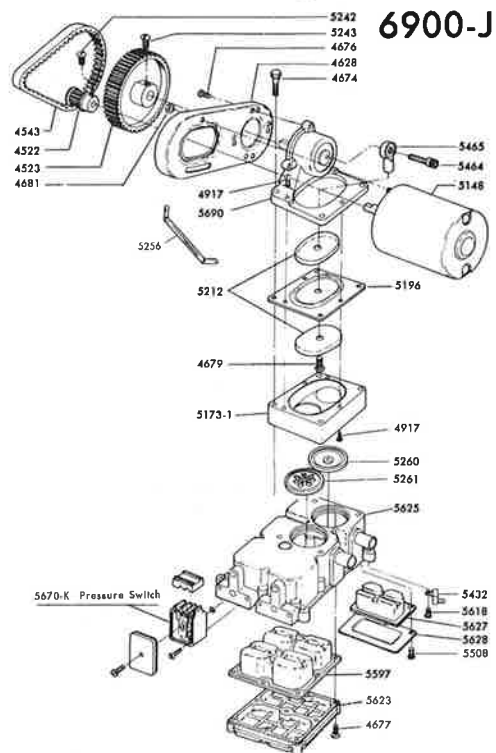

5625	Base Assembly Model 6800-J	11.50
5625-2	Base Assembly Model 6850-J	11.50
5627	Pulsation Dampener	1.75
5628	Bottom Plate	1.00
5647	A. C. Motor 115 Volts	70.00
5648	Capacitor for 5647 Motor	3.15
5649	Relay for 5647 Motor	6.30
5660-K	Pressure Switch	12.75
5661	Motor Adaptor for 5647 Motor	2.75
5670-K	Pressure Switch	12.75
5671	Box for Capacitor and Relay	2.25
5675-K	Dry Tank Switch	12.75
5680-K	Pressure Switch	12.75
5686	Bottom Plate	1.00
5689	Jack Shaft Assy.	14.00
5690	Jack Shaft Assy.	14.00
5697	Jack Shaft Assy.	14.00
620R	Eccentric Screw	.10



PETERS AND RUSSELL, INC., ITT, SPRINGFIELD, OHIO 45501
A SUBSIDIARY OF INTERNATIONAL TELEPHONE AND TELEGRAPH CORPORATION
WATER PRESSURE SYSTEMS

PUMP SPECIFICATIONS

INSTRUCTIONS FOR	MODEL	NUMBER OF OUTLETS	SUCTION LIFT FT., MAX.	DISCH'GE HEAD FT., MAX.	MAX. OPERATING AMPS. INTERMITTENT		FUSE SIZE SLOW BLOWING		SIZE OF UNIT
					12 V	32 V	12 V	32 V	
	6969-J	1	5	6	5.2	2.2	4	2	4 1/8 w. x 7 3/8 lg. x 7 1/4 hi.
	6970-J	2	5	6	6.2	2.6	6 1/4	3	6 5/8 w. x 7 1/8 lg. x 7 1/4 hi.
	6950-J 6955-J	4	5	7	6.2	3.8	6 1/4	3	6 5/8 w. x 5 5/8 lg. x 8 5/8 hi.
	6800-J 6850-J	5	5	12	9.9	3.8	6 1/4	3	8 3/8 w. x 5 5/8 lg. x 8 5/8 hi.
	6900-J	6	5	10	9.9	3.8	10	5	8 3/8 w. x 5 5/8 lg. x 8 5/8 hi.

*If installed pump draws in excess of these ratings, motor burn-out will result.

INSTALLATION, OPERATING AND MAINTENANCE INSTRUCTIONS

PLEASE LEAVE THESE INSTRUCTIONS FOR THE OWNER

READ CAREFULLY

IMPORTANT: To insure your warranty and receive automatic trouble-free water with a minimum amount of maintenance, these instructions must be studied carefully.

1. MOUNTING:

1.1 Unit is self-priming, securely mount in a dry ventilated location in an upright position above or below (above preferred) the fresh water tank in accordance with specification chart above.

1.2 **IMPORTANT** — Keep outlets of Model 6969-J at least 6" above fresh water tank to avoid siphoning action.

2. WIRING:

2.1 Wire in independent circuit in accordance with NFPA Standard No. 302, table 6, or select size from the following charts which give AWG wire size determined by load and total length of wire.

USE 5 amp chart for all 32-volt models.

USE 10 amp chart for all 12-volt models.

**LENGTH OF CONDUCTOR IN FEET FROM SOURCE OF CURRENT AND RETURN
AWG WIRE SIZE — COPPER**

Total Current in Amps	— feet —					
	10	20	30	40	50	60
12 volts @ 10 amp	12	12	10	8	8	6
32 volts @ 5 amp	16	16	16	16	14	14

**AWG WIRE SIZE — ALUMINUM
NOT RECOMMENDED FOR MARINE USE**

Total Current in Amps	— feet —					
	10	20	30	40	50	60
12 volts @ 10 amp	10	10	8	6	6	6
32 volts @ 5 amp	14	14	14	14	12	12

2.2 FUSING:

a. Protect by a separate overcurrent fuse located in live lead from power source.

b. Rate fuse as per specification chart or not over 115% of full motor load.

2.3 Use 10 amp manual switch in circuit to turn off unattended, stored or in transit pump.

2.4 a. Connect power leads as shown in fig. 1 and fig. 2. Connections must be electrically, mechanically and

galvanically sound to withstand normal service, use spade or solderless connector.

b. Alternate remote method of wiring dry tank switch. Dry tank switch may be wired in with a good quality 10 amp. push button, momentary type switch in addition to starting button at pump. Locate at most convenient outlet. This allows the unit to be started from either position. Use 14 ga. wire and make connections as shown in Fig. 2.

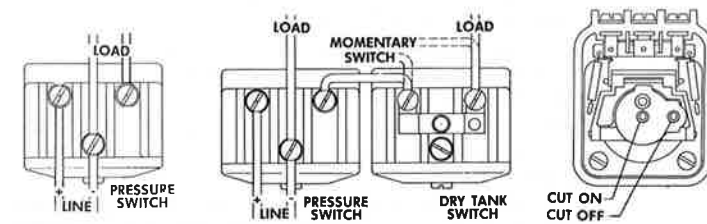

Fig. 1

Fig. 2

Fig. 3

c. When aluminum wire is used, make connection to switch by using 3 to 4 inch pigtailed of 12 ga. copper wire attached to the solid aluminum wire with 3M Scotch Grab R10-16 twist type connections or equivalent. CAUTION: Use a Burndy or equivalent connector paste to avoid galvanic action between dissimilar metals.

2.5 D.C.V. converter charger pack should be wired so pump is operating directly from battery at all times.

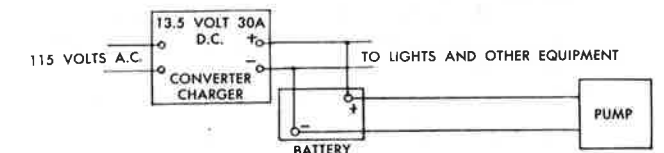

Fig. 4

2.6 It is recommended after installation, voltage be checked at the motor under full load with all other appliances used in the circuit operating. Be sure it is not less than 11 volts on a 12 volt system or 30 volts on a 32 volt system with a fully charged battery.

MB

IMPORTANT!
WHEN ORDERING REPAIR PARTS, ALWAYS GIVE THE FOLLOWING:
1. PUMP No. 3. PART No.
2. SERIAL No. 4. PART NAME
ON EACH ELECTRIC PUMP

2.7 Check amperage draw of the installed pump. This reading should be taken at the motor with the pump operating under its worst working condition. Amperage must not be in excess of limits stated on specification chart, "Maximum operating amps intermittent," page 1.

WARNING: Our warranty does not cover motor and/or pressure switch burnout caused by low voltage or error in installation. It is very important that wiring and plumbing be as per instructions and enough current is received at the pump for proper operation.

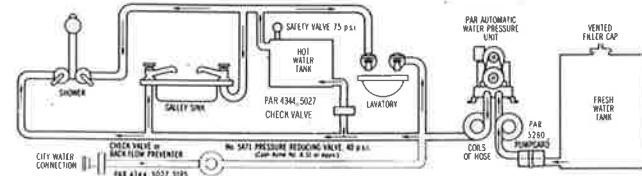

TYPICAL PAR WATER PRESSURE SYSTEM INSTALLATION

3. PLUMBING:

Pump is designed to deliver trouble-free water with a minimum amount of maintenance if installed properly. Follow plumbing instructions carefully.

3.1 To keep pressure drop to a minimum, calculate pipe and tubing sizes in accordance with the number of outlets as per the following chart.

Number of Fixtures	Tubing		Pipe
	Inner Diameter (Inches)	Outer Diameter (Inches)	Iron Pipe Size (Inches)
1	3/8	1/2	1/2
2	3/8	1/2	1/2
3	1/2	3/4	1/2
4	1/2	3/4	1/2
5 or more	3/4	3/4	3/4

3.2 Valves, tees, elbows, etc. used should be same size as pipe or tubing. Use gate valves only.

3.3 Water purifiers should be installed in separate outlet for drinking water only due to the high restriction.

3.4 Use household type faucets. Remove aerator screens. Remove sealing washer from faucets when used with model 6969-J. Do not use quick closing faucets.

3.5 Fresh water tank must be vented. Locate or baffle to prevent water from getting away from outlet causing airlock in pump.

3.6 PRESSURE REDUCING VALVE—Systems having a connection for an outside source of water should be equipped with a pressure reducing valve when installed on boats, may be equipped with a pressure reducing valve when installed in trailers and campers, regulated at approximately 40 PSI to avoid damage to pump and plumbing from excessive city pressure.

CAUTION: PUMP MAX. WORKING PRESSURE 125 PSI.

3.7 CHECK VALVE—To prevent the backflow of pressure and/or hot water into cold water lines, a reliable check valve should be installed at the cold water inlet to the hot water heater. This valve should be located far enough from the heater to prevent damage to the check valve seat from excessive heat.

3.8 STRAILER—A PAR #5280 Pumpgard in inlet line to pump may be used to avoid valve clogging caused by accumulation entering pump.

3.9 Pump should be connected to plumbing using both lengths of hose supplied. Use a minimum of 8' of metal pipe or tubing between discharge hose and water heater or check valve to avoid getting heat into hose which is intended for cold water use only.

3.10 a. RELIEF VALVE—Systems equipped with a storage water heater or closed hot water tank should incorporate a pressure relief valve and Energy Cutoff equipment or a Pressure Temperature type relief valve. Relief Valves should be sized to a BTUH rating equal to or above that of the water heater and be equipped with a full size drain.

PETERS AND RUSSELL, INC.

Temperature relief valves or combination temperature pressure relief valves shall be located within three inches of the hottest part of the tank or water heater. Valves should be adjusted to a relief at a maximum pressure of 75 PSI and maximum temperature of 210°F.

b. Systems using engine heat exchanger should be equipped with a 75 PSI maximum relief valve located at the cold inlet between exchange and fresh water system.

4. OPERATION:

4.1 To start pumps equipped with pressure switch only:

- Check level of fresh water tank.
- Be sure all valves and strainers are open.
- Open all outlets and turn on power to pump.
- Keep outlets open until all air is cleared from lines, close outlets, pump is ready for operation.
- Open seacock when pump is used for deck wash down.

4.2 To start pumps with Dry Tank Switch, follow the above procedure and depress and hold red button or momentary switch until all air is cleared from lines. Close faucets and release button or switch. This will set contacts in Dry Tank Switch. These will then remain closed until line pressure has dropped to approximately 2 PSI.

NOTICE: It is necessary to restart pumps equipped with Dry Tank Switch if pressure drops below 2 PSI.

CAUTION: Do not adjust pressure switch for high pressure.

5. DRY TANK SWITCH

Dry Tank Switch on Models 6850-J and 6955-J Pumps only have been regulated at factory to hold in at 8 PSI and turn off unit when pressure drops to 2 PSI. Due to differences in installation, these settings may require changing if the following symptoms occur. Fig. 3

SYMPTOM: SWITCH OPENS, STOPPING PUMP WHEN FAUCET IS OPEN OR WHEN PUMP HAS BEEN MANUALLY TURNED OFF FOR SOME TIME.

CURE:

- Check system for leaks which will allow a drop in pressure.
- Check pump valves for foreign material which would hold them open and not allow enough pressure to develop to hold the switch in.
- Check voltage. Low voltage will not allow the unit to develop enough pressure to hold switch in.
- If it is found that the trouble is other than that above, then a small amount of restriction must be added to back pressure the pump. This may be done by pinching the pump hose on the discharge side or by adding a short piece of smaller copper tubing in the hose. Care must be taken when adding this restriction to avoid overloading the pump or building pressure to a point where the switch cannot drop out when the supply is depleted. (See instructions below).

SYMPTOM: SWITCH WILL NOT TURN PUMP OFF WHEN WATER SUPPLY IS DEPLETED.

CURE:

Remove cover and turn cut-on screw (one in center) clockwise until pump turns off when supply is exhausted. Do not over adjust.

The length of time required for the pump to turn off is dependent upon the size of the system. An example is the pump on a larger system will run longer after the tank is dry than a smaller system due to the length of time required for the pressure to drop.

6. MAINTENANCE AND TROUBLE-SHOOTING:

6.1 **SYMPTOM:** PUMP DOES NOT PRIME OR BUILD UP PRESSURE.

CURE:

- Check level of fresh water tank.
- Check pump and system for leaks.
- Be sure all valves and strainers are open.
- Check power supply to see that voltage is up.
- Under certain conditions on systems having outlets in excess of 7', it is necessary after refilling fresh water tank to bleed all air from system by opening both highest and lowest outlets with pump running. This

may also be accomplished by the addition of a drain valve located as per fig. 5 to bleed off excessive head.

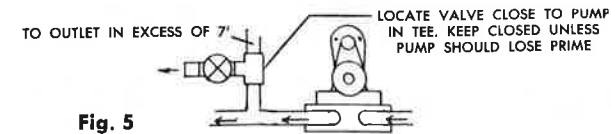

Fig. 5

f. Dismantle unit and check valve assemblies for foreign material between the valve and valve seat causing loss of suction. This is done without disturbing plumbing or wiring as follows:

- Close line between fresh water tank and pump.
- Turn pump off and bleed pressure through faucet.
- Remove tie-down screws.
- Lift motor, drive and diaphragm assembly off base.
- Lift valve assemblies from pockets and clean all foreign material from valve and valve seat.
- Replace valve assemblies back in same pockets, being sure rubber valve with small hole is UP on intake and rubber valve without small hole is DOWN on discharge. **CAUTION:** Do not use valve with small hole in rubber on discharge side of pump. Diameter of hole must not be increased.

6.2 **SYMPTOM:** PRESSURE DROPS AND PUMP COMES ON PERIODICALLY WHEN WATER IS NOT BEING DRAWN.

CURE:

- Check pump, pressure reliefs, all connections and faucets for leaks.
- Remove four tie-down screws and check valves for foreign material as per paragraph 6.1 f.

6.3 **SYMPTOM:** PUMP IS ROUGH AND HAS EXCESSIVE NOISE.

CURE:

- Check to see that plumbing (especially inlet) is not restricted.
- Be sure both pieces of hose supplied have been used as per plumbing instructions.
- Remove aerator from faucet, these cause restriction (especially when blocked by dirt).
- Check balance of plumbing to see that it is not hitting anywhere and amplifying what may be normal pump vibration.
- Do not use hard seat check valves.
- Check pulsation dampeners for ruptures or loss of air. Dampeners may be replaced as follows, Models 6969-J and 6970-J.
 - Remove #5686 plate and remove dampener. Place new dampener in place and refasten plate making sure flange of dampener is correctly seated to effect a proper water and air seal.
- Models 6950-J and 6955-J:
 - Pulsation dampeners are replaced in same manner as above by removing #5686 bottom.
- Models 6800-J, 6850-J and 6900-J have two independent dampeners, one inlet and one discharge. Discharge dampener may be replaced by removing #5623 bottom. It is also advisable at this time to replace the inlet dampeners by removing three additional screws and #5628 plate.

IMPORTANT: All dampener flanges must be properly seated to effect a good water and air seal.

CAUTION: To avoid casting damage and obtain proper compression on dampener flange, tighten screws evenly until flange edge of #5686 steel plate is flush with bottom of base casting.

On pumps using #5623 bottom cap: Compression is correct when flange of #5623 cap is against bottom of base. Tightening of screws beyond this point may result in casting damage.

6.4 **SYMPTOM:** BROKEN CASTING.

CURE: a. Always drain pump and system to prevent breakage from freezing.

b. Install pressure relief valves and regulators as instructed. Pump castings can be broken from either thermal expansion of heated water or if unit is attached to city water in areas having high pressure. This condition is also true for the balance of the plumbing and fixtures used in the system.

6.5 **SYMPTOM:** MOTOR AND/OR PRESSURE SWITCH BURN-OUT.

CURE: The normal cause of motor and switch burnout is either low voltage, overpressure or a combination of both. Use proper wiring and plumbing as shown in the previous instructions and keep battery charged. The pump, like any other piece of machinery cannot operate properly unless it receives enough power and is installed correctly.

6.6 **SYMPTOM:** DECREASE IN BELT LIFE.

CURE: Belt has proper tension if it can be moved in and out on one side a total of 1/4" at a point halfway between pulleys.

ADJUST BELT AS FOLLOWS: Loosen #4681 nuts on end of motor and slide motor up or down until desired tension is gained and retighten nuts.

6.7 **SYMPTOM:** CONNECTING ROD NEEDS RE-OILING (Models 6969-J and 6970-J)

CURE: The connecting rod bearing is made of grease-impregnated iron and cover is packed with enough lubricant to last approximately 500 hours. Relubricate by removing cover and packing built-in reservoir with black chassis lube which may be obtained at most automotive service stations.

6.8 **PRESSURE SWITCH AND/OR DRY TANK SWITCH REPLACEMENT:**

To remove either or both switches, relieve pressure from pump and disconnect motor wires and power leads.

Remove front cover and two screws located at bottom corners inside switch case.

Replace new switch being sure "O" Ring is seated properly around bottom stub on back of switch case. Care must be taken to avoid thread damage when reinstalling switch. Rewire per Fig. 1 and 2.

7. FALL LAY-UP:

7.1 Whenever possible, it is preferable to store PAR Water Systems in a warm, dry place free from freezing and condensation. The complete unit need not be removed, only the motor, diaphragm, and valve assemblies. This is done as follows:

- Pump system dry as possible through faucets, open drains.
- Remove (4) tie-down screws, and leads to pressure switch.
- Lift motor and diaphragm assembly from pump.
- Remove valves from pockets and clean.
- Store in warm, dry place.

7.2 When removal for winter storage is not possible, the unit should at least be drained as follows to prevent freezing.

- Pump tank and plumbing dry through faucets, open drains.
- Leave faucets open and turn pump off.
- Disconnect outlet connection.
- Start pump and allow to run until all water is expelled from unit. (Running dry will not harm the pump.)
- Do not reconnect unit until warm weather unless plumbing is completely void of water.
- If system is arranged with city connection on discharge side of pump, pump nor inlet lines to pump from fresh water tank will be cleared of water by blowing air through city connection. Follow the above procedure and/or vehicle manufacturer's draining instructions.