



SmartH



Hello, Smart Home





SMARTH

– Home Automation –

WELCOME TO SMARTH

Welcome to the Smarth Family!

Great choice picking up the Smarth SMART DOOR LOCK – It's one of our favorite products in the Smarth lineup. The information contained in this brochure explains the features and operation of the SMARTH DOOR LOCK. Please take a few moments to read this manual.

We are excited for you to start enjoying it!

Installation & Operation Guide Keypad Electronic Lock

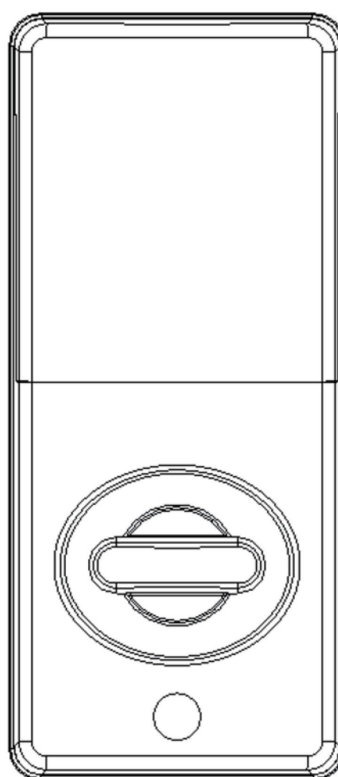
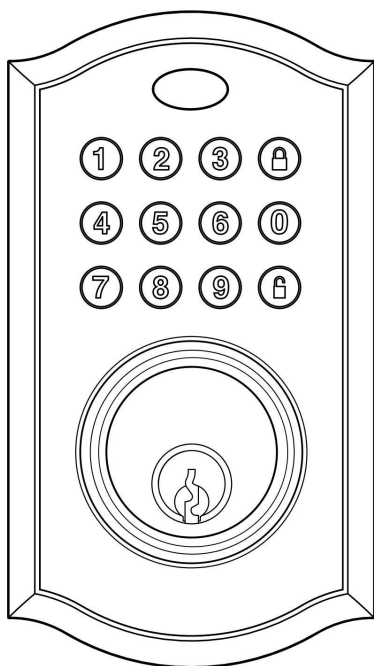

Specifications

Product Name: Smart Door Lock
Communication Type: Bluetooth
Unlock Type: Password/Code,App,Mechanical Key
Material: Metal+ABS
Batteries: 4 AA Batteries Required
Battery life: 6 Months
Auto-Lock Function: Support
Customizable User Codes: 10 Users Codes,6-10 Digits
Item Weight: 1174g
Door Thickness Compatibility (mm) : 35mm- 50mm
Lock Style Options: Standard 60-70mm Lock Body
Size(L x W x H): 133 x 74 x 28 mm
Locks compatibility: Self-contained Single Cylinder Deadbolt

Components list

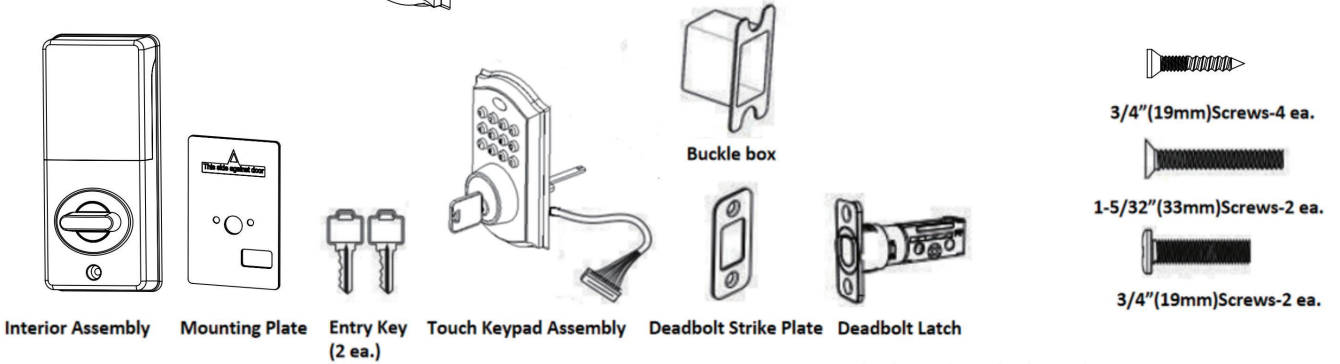
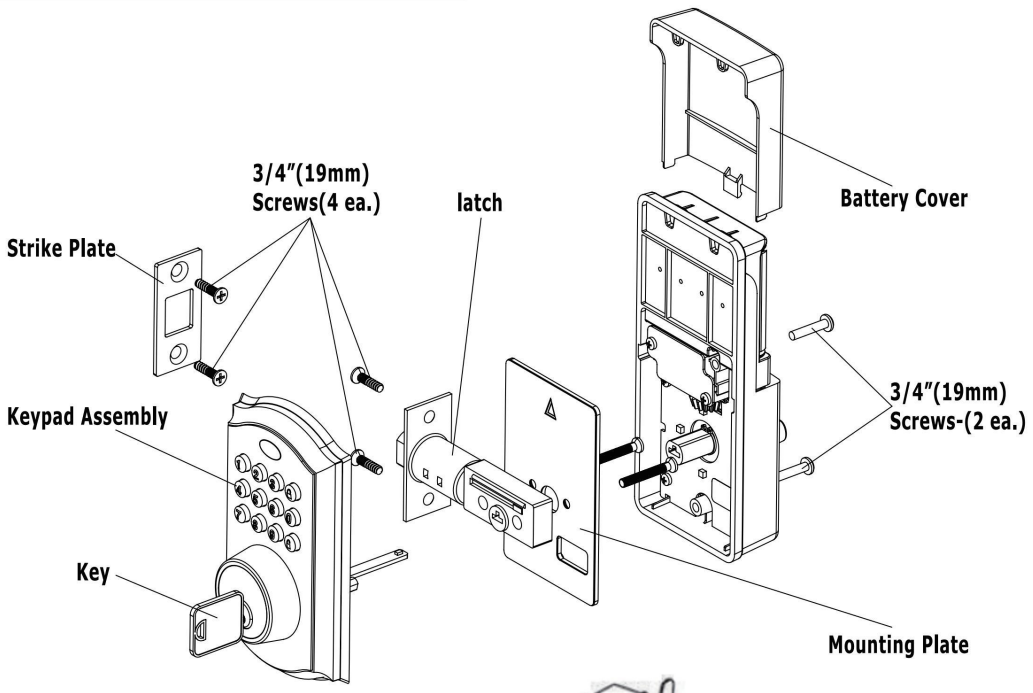

Tools Required

Tools Required for Installation on Pre-drilled Doors:

- Phillips Screwdriver (DO NOT USE POWER DRILL !) 



Installation Guide **STEP 1**

Prepare the door and check dimensions

If drilling a new door, use the supplied template and the complete door drilling instructions

1. Measure to confirm that the hole in the door is 2-1/8" (54 mm).

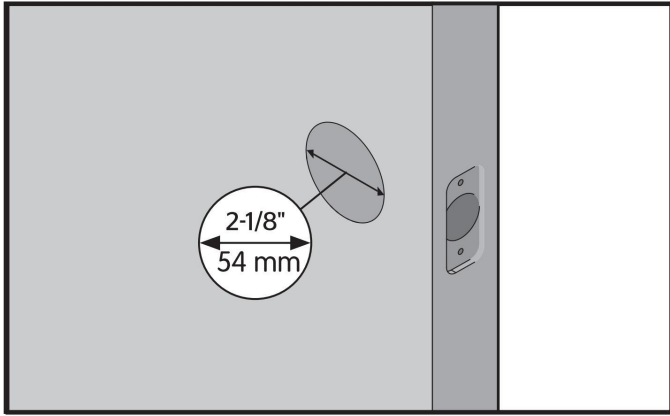

2. Measure to confirm that the backset is either 2-3/8" or 2-3/4" (60 or 70 mm).

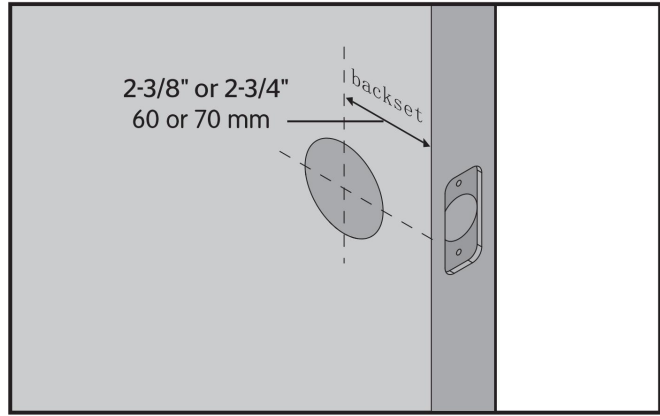

3. Measure to confirm that the hole in the door edge is 1" (25 mm).

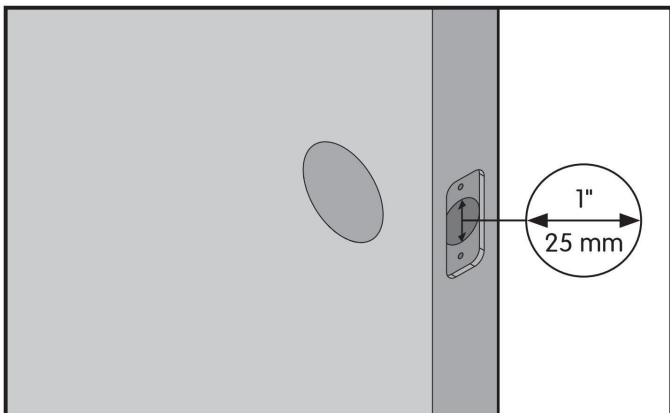

4. Measure to confirm the thickness of the door is between 1-3/8" and 2" (35mm and 50mm).

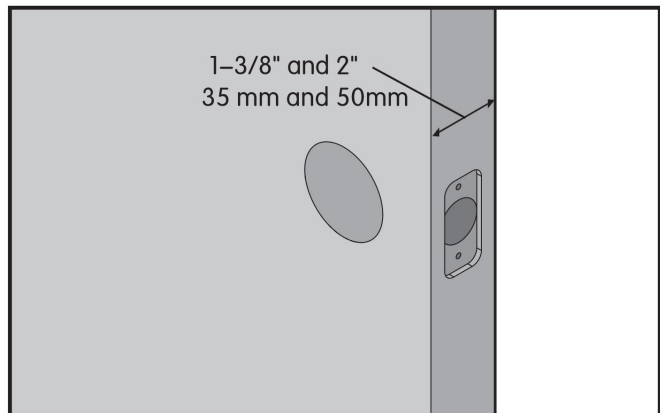

Installation Guide **STEP 2**

Install the latch and strike

1. Insert the latch bolt into the door.

Actual Size
3/4"(19mm)Screws-2ea.

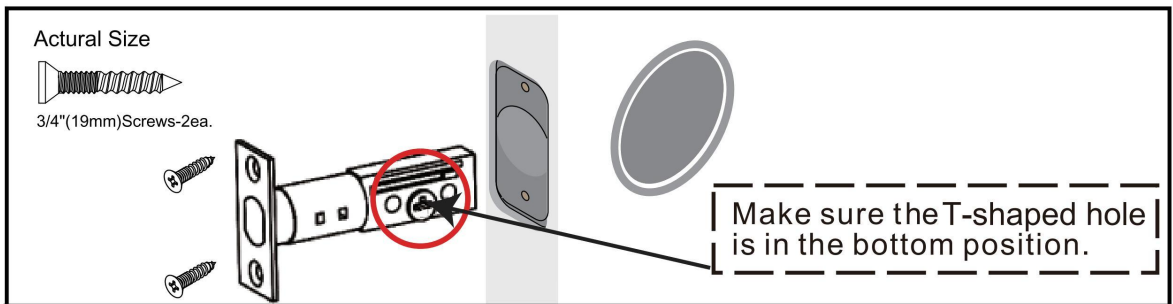

Make sure the T-shaped hole is in the bottom position.

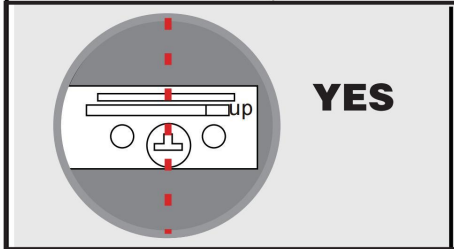
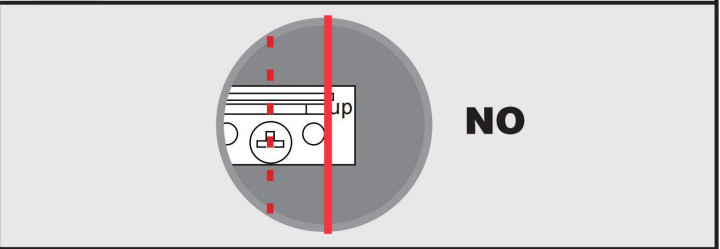
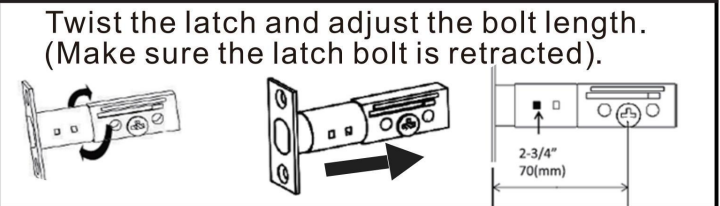
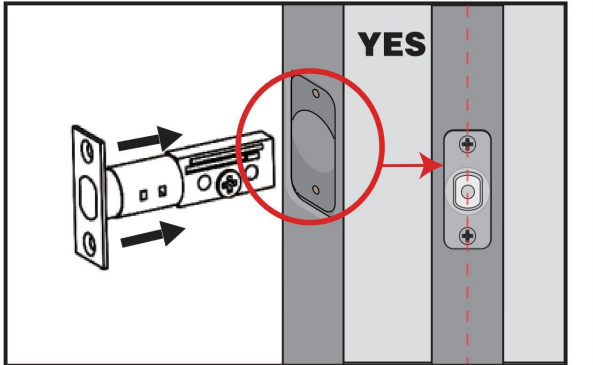
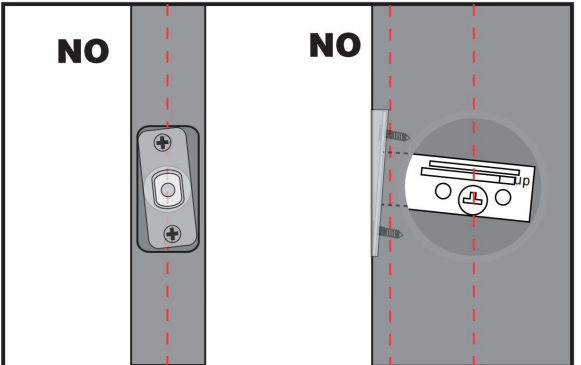
 <p>YES</p>	 <p>NO</p>
No adjustment is required. Proceed to next step.	Twist the latch and adjust the bolt length. (Make sure the latch bolt is retracted). 
 <p>YES</p>	 <p>NO</p>

2. Install strike on the door frame.

Actual Size
3/4"(19mm)Screws-2ea.

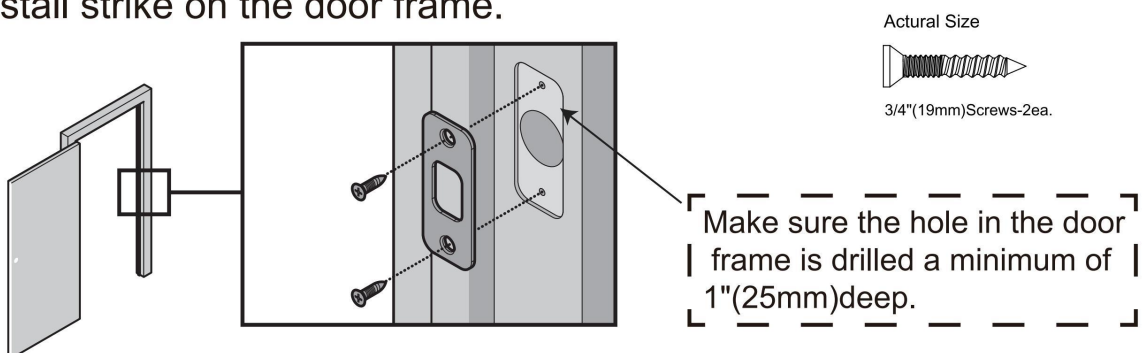

Make sure the hole in the door frame is drilled a minimum of 1"(25mm)deep.

Installation Guide **STEP 3**

Install the exterior assembly

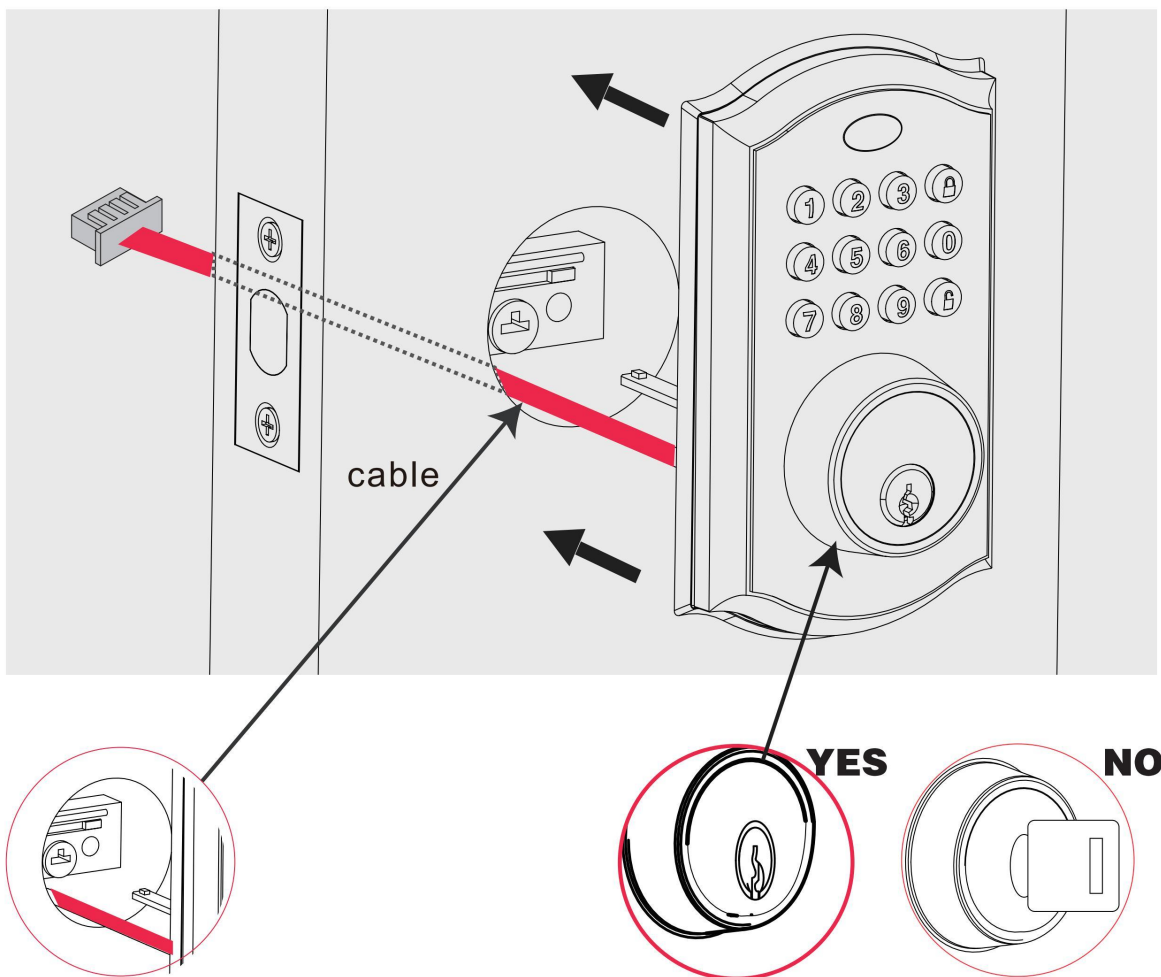

Route the cable through the door below the bolt, and push the keypad onto the door.

The key must be pulled out when installing.

Installation Guide **STEP 4**

Install the interior assembly

1. Take off the mounting plate.

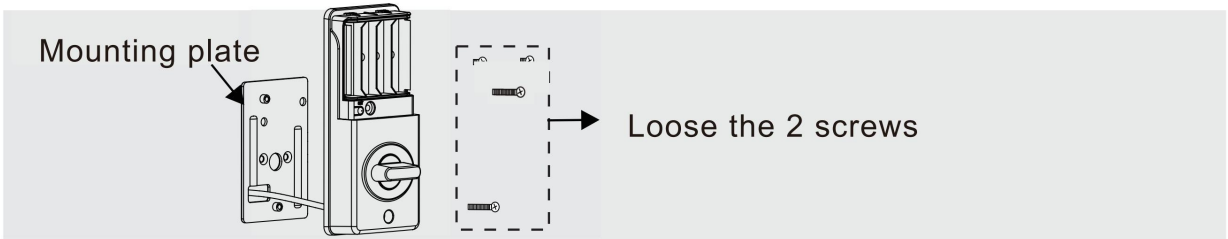

2. Route cable through the bottom of mounting plate.

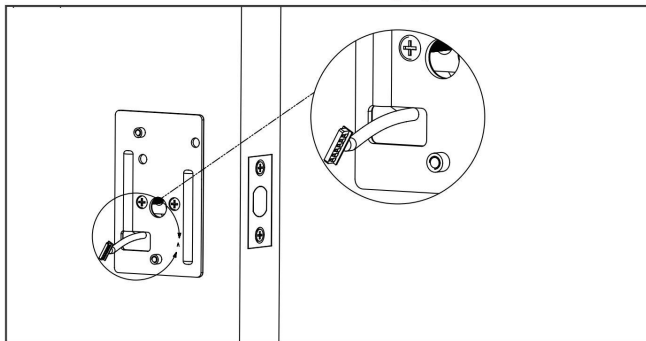

3. Tighten screws evenly.

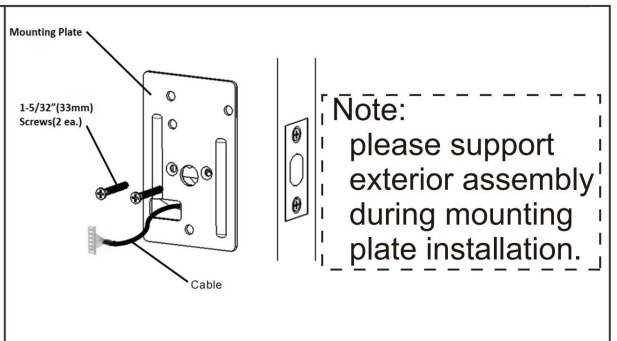

4. Ensure tight cable connection.

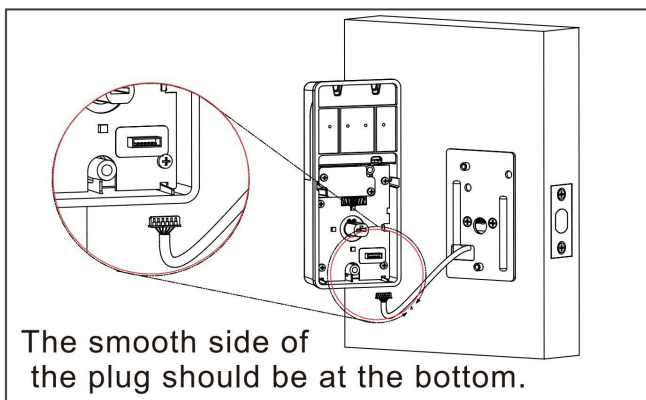

5. Tighten screws evenly.

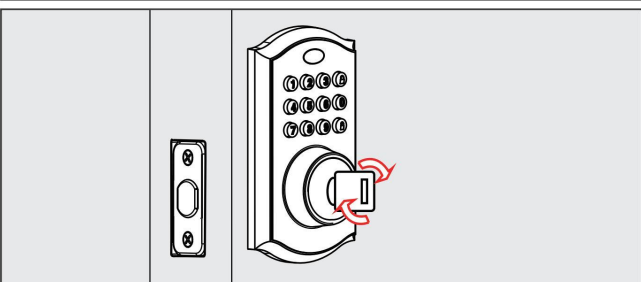
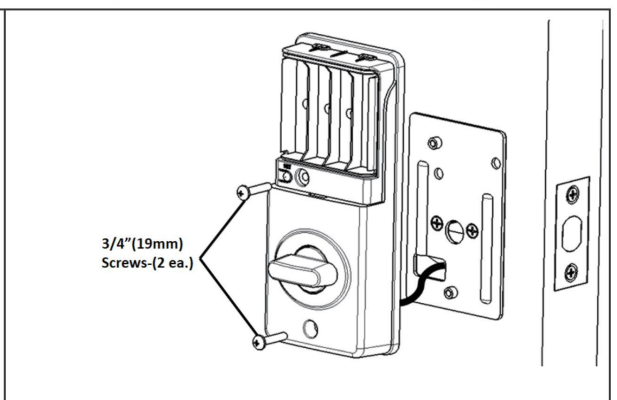

Insert key and test latch.
if latch does not extend or retract smoothly,
please adjust mounting plate screws.

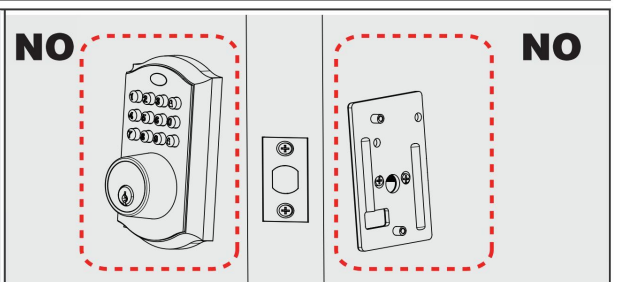

If the keypad and mounting plate are deflection,
please loose mounting plate screws
and adjust.

Installation Guide **STEP 5**

Install the batteries and perform the door handing process

Note: Do not use rechargeable batteries or Non-alkaline batteries.

1. Install 4 AA batteries in battery pack.

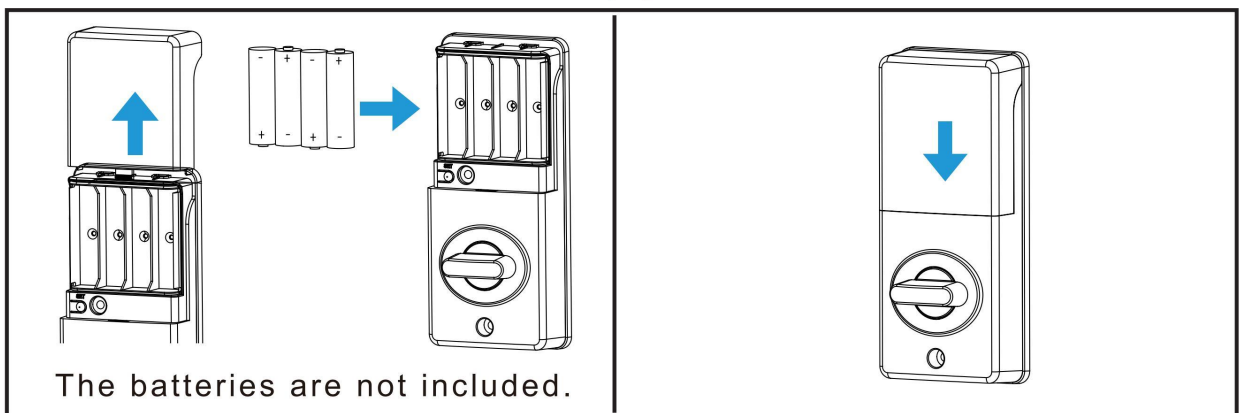

2. Perform the door handing process.

Press , the latch bolt extends by itself.



If the latch bolt extends or retracts not smoothly, please check the latch and re-install the lock.

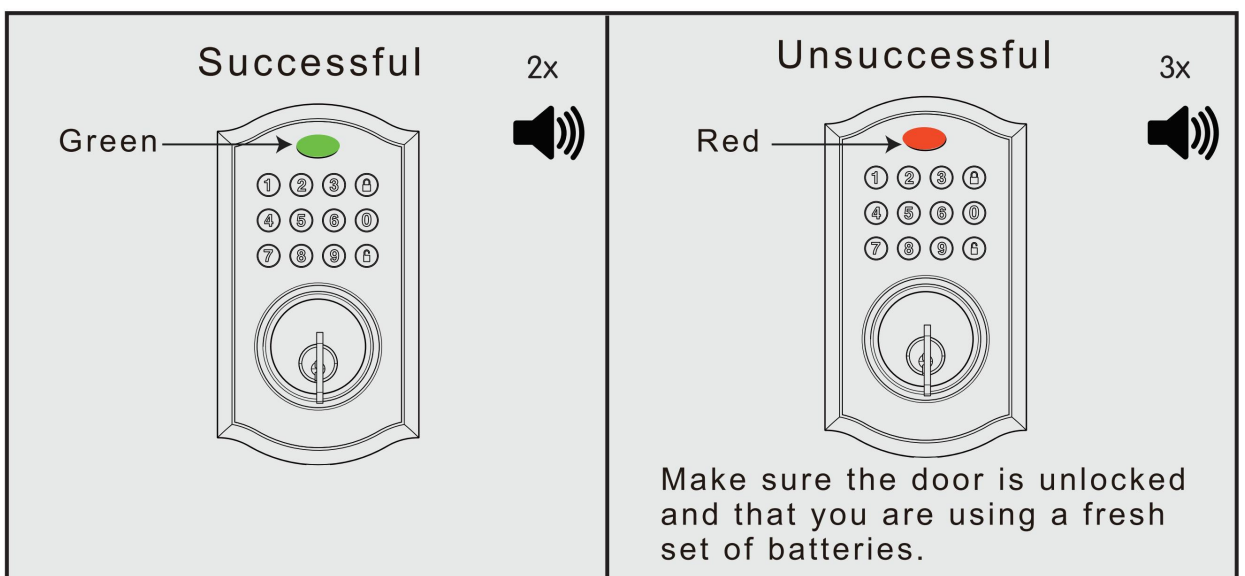

Advanced setting optional

How should I do if I can't connect to smart lock

Restart the Bluetooth, and try again.

How many passwords can be added

It can be added for ten passwords.

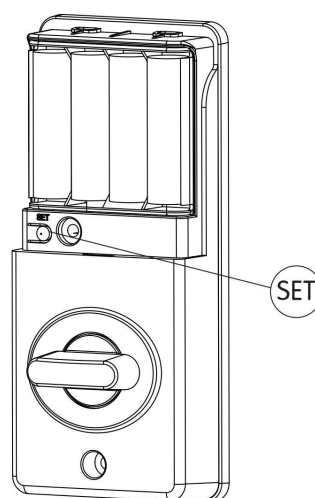
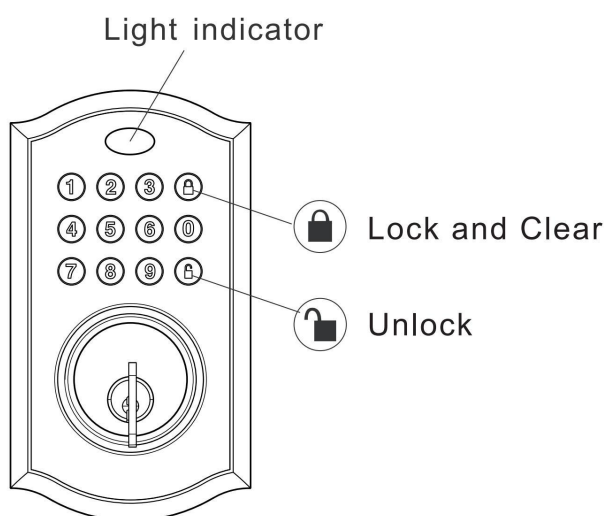

Protection mode:

If you enter the wrong code 5 times, the keypad will be locked 90 seconds when you press any button, you will hear 3 beeps and 3 red lights.

How to exit protection mode:

option 1. wait for 90 seconds and the protection mode will be exited.

option 2. remove the battery for more than 5 seconds, and then reinsert the battery.

Factory default reset

A factory reset will delete all codes associated with the lock.

1

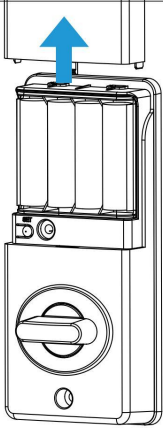

Open the battery cover.

2

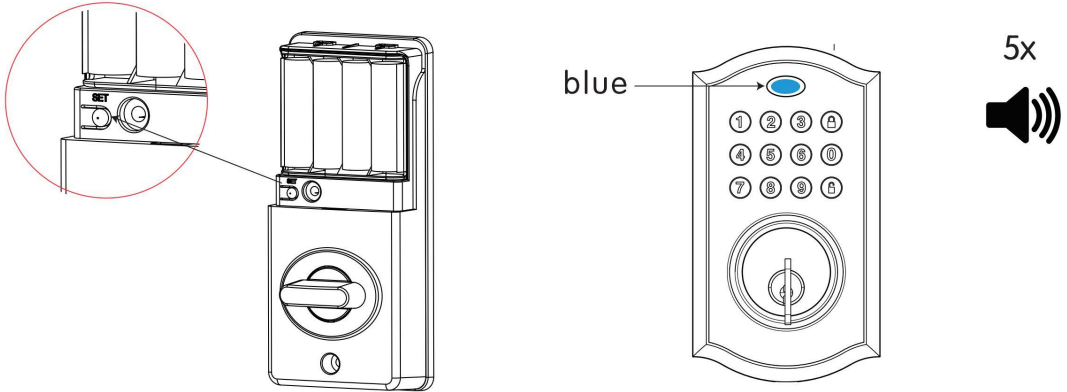

Keep press holding set button more than 5 seconds until the lock short beeps 5 times and light flash blue 5 times. then the beeps 1 second and light flash green 1 times. the lock has been reset successful.

System Alerts

Alert	Reason	Solution
button flashes red 3 times with 3 beeps.	Door jammed while attempting to lock.	Manually re-lock door. If needed, reposition strike.
	Incorrect User Code ente red.	Re-enter User Code.
button flashes red 3 times with 3 beeps.	5 incorrect User Codes entered within one minute.	Re-enter User Code after 90 seconds keypad lock out.
LED redlight when press any button.	Low battery.	Replace batteries.
LED redlight when press any button. and can not unlock/lock.	Super low battery.	
LED green light and beeps 1 second after press unlock/lock button. the lock no respond.	Poor quality battery.	
The keypad and light indicator no respond.	Battery run out.	Use Micro-Usb supply power to unlock or key to unlock then replace batteries.
	Bad cable connection.	Re-connect the cable.

Prepare Door And Jamb

1. TEMPLATE

- Cut out template printed of this Manual (Figure 1a).
- Fold template and place on door 36" (915mm) from the ground as marked (Figure 1b).

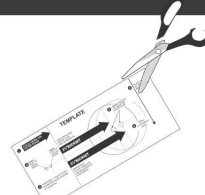

Figure 1a



Figure 1b

2. MARK THE DOOR FOR DRILLING

- Mark center hole on door edge through guidance on template for 1" (25mm) latch bolt (Figure 2a).
- Mark center hole on door face through guidance on template for 2-3/8" (60mm) or 2-3/4" (70mm) (Figure 2b) backset .

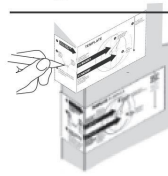

Figure 2a



Figure 2b

3. DRILL AND CHISEL DOOR

- Drill 2-1/8" (54mm) hole through door panel as marked for lock set (Figure 3a).
- Drill 1" (25mm) hole in center of door edge for Deadbolt Latch Assembly (Figure 3b).
- Insert Deadbolt Latch Assembly in hole keeping it parallel to face of door. Mark outline and remove latch (Figure 3c).
- Chisel 5/32"(4mm) deep or until latch face is flush with door edge (Figure 3d).

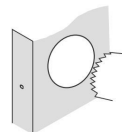

Figure 3a

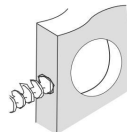

Figure 3b

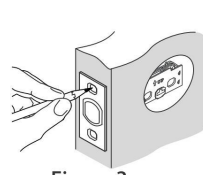

Figure 3c

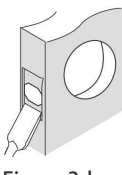

Figure 3d



NOTE: For Drive in Latch, drill hole size indicated on template and press until it is flush with door edge.

4. MARK AND DRILL DOOR JAMB

- Mark center hole on edge of jamb even with the center of the Latch Bolt on door edge. (Figure 4a).
- Drill 1" (25mm) hole 1-3/16" (30mm) deep in door jamb on center mark (Figure 4b).
- Outline outside edges of Strike Plate (Figure 4c).
- Chisel 5/32"(4mm) deep for Strike Plate or until it is flushed (Figure 4d).
- Install Strike Plate using two 3/4" (19mm) screws provided (Figure 4e).

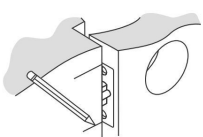

Figure 4a

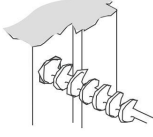

Figure 4b



Figure 4c

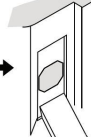

Figure 4d

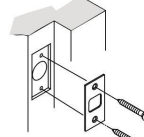

Figure 4e

Tools Required

Tools Required for Installation on undrilled Doors:

- Phillips Screwdriver (DO NOT USE POWER DRILL!) 

Install Free App

Download APP: scan the QR code below to download and install. Register and login: open the "MySmarth" APP to register and login according to the prompts.



Customer Support



1. Set Up Router

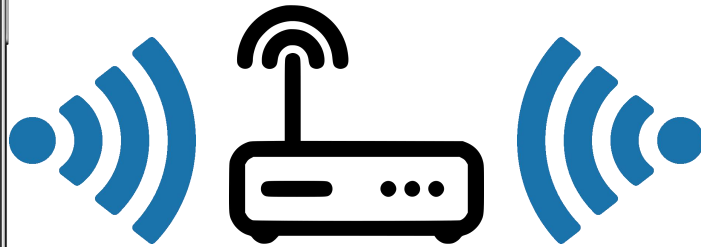
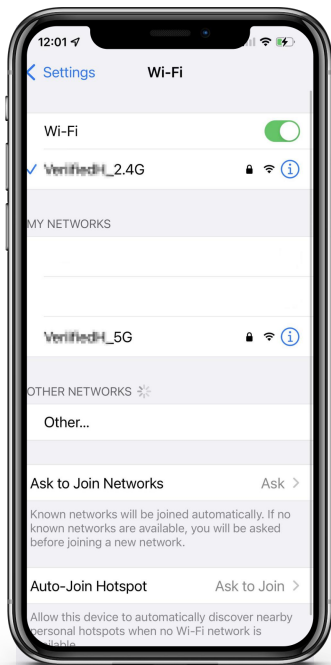

Please keep network available

2.4GHz

5GHz



The router supports the 2.4GHz WiFi (doesn't support the 5GHz), and is connected to the WiFi network. Please set the parameters of the router before connecting the WiFi network, and record the SSID and password of your WiFi.

2. Turn On Your Smartphone's Bluetooth



Turn on your smartphone's Bluetooth.

Connect the Smart Lock to MySmarth App

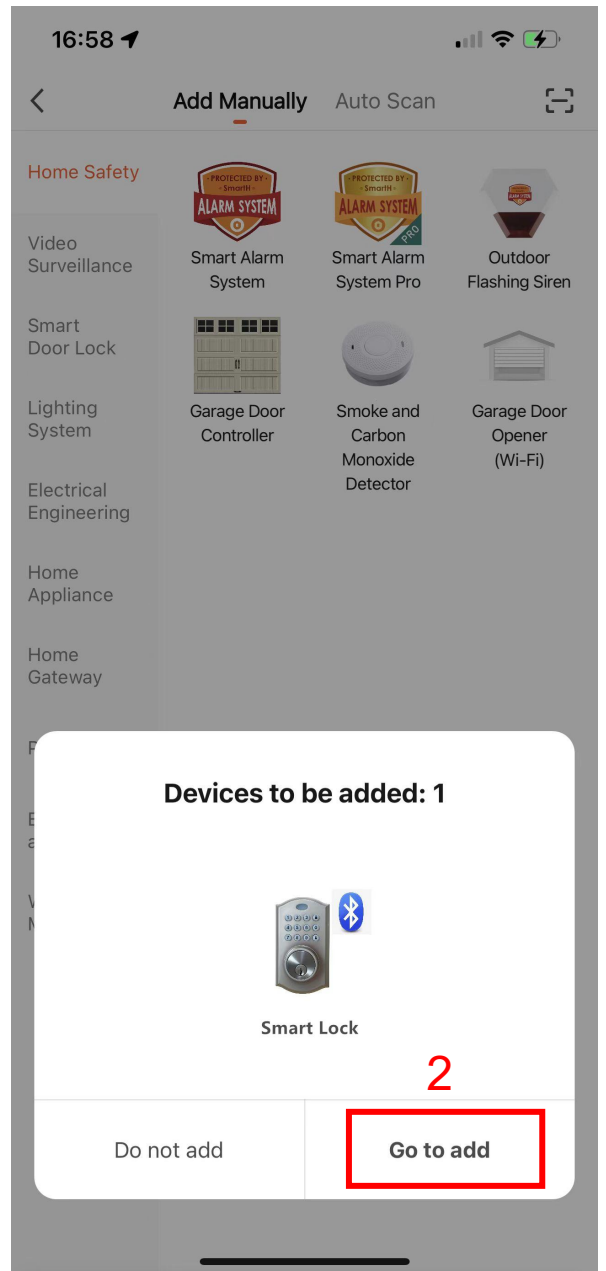
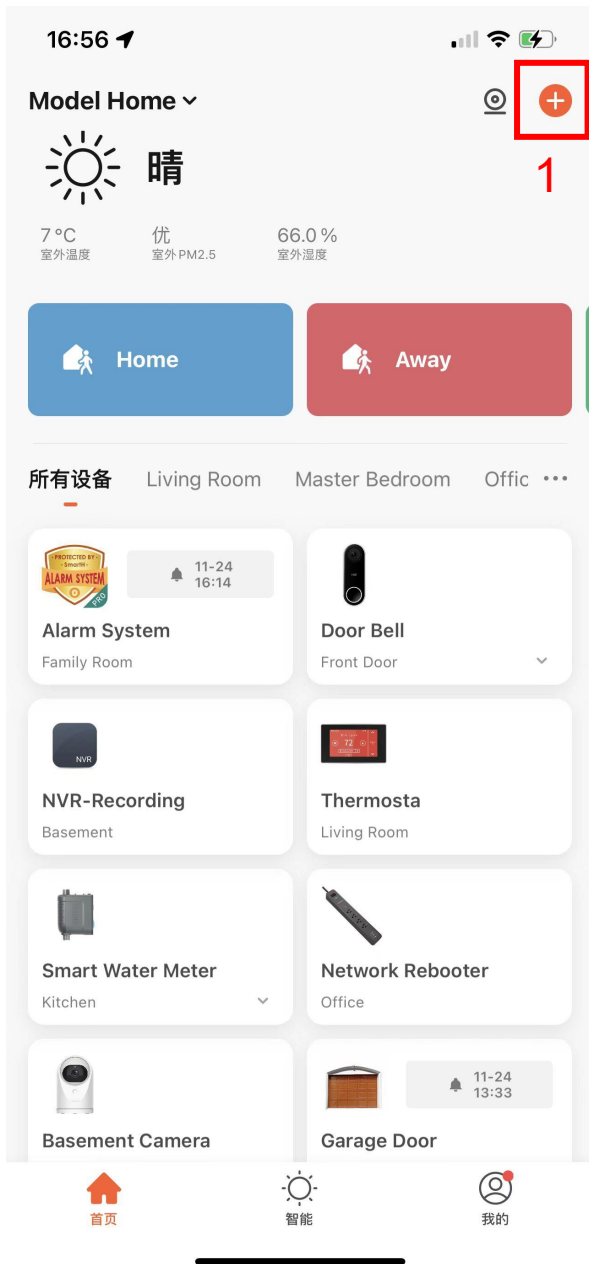

1. Launch the app and tap the Plus (+) in the top right corner to add a device.

2. Tap “Go to add”

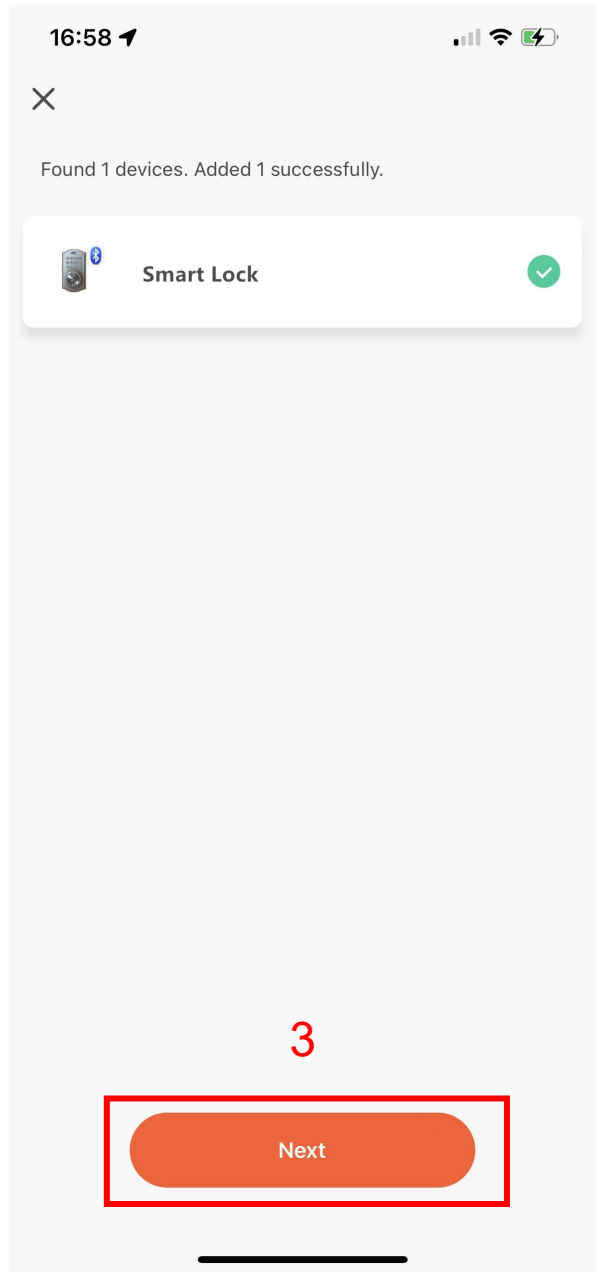
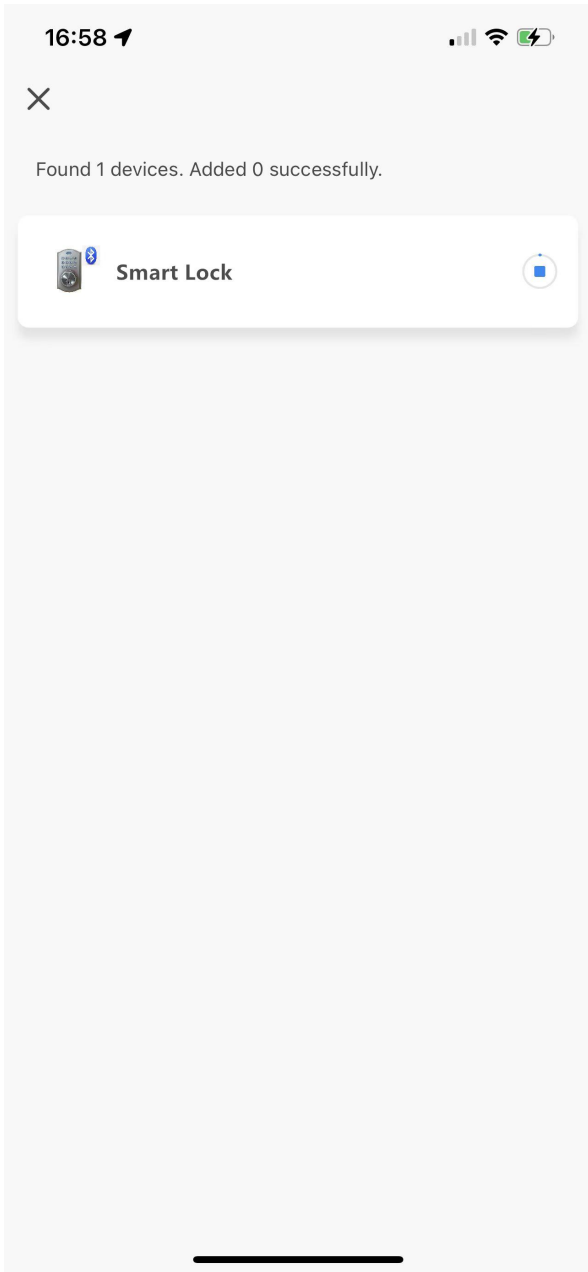

3. Tap "Next"

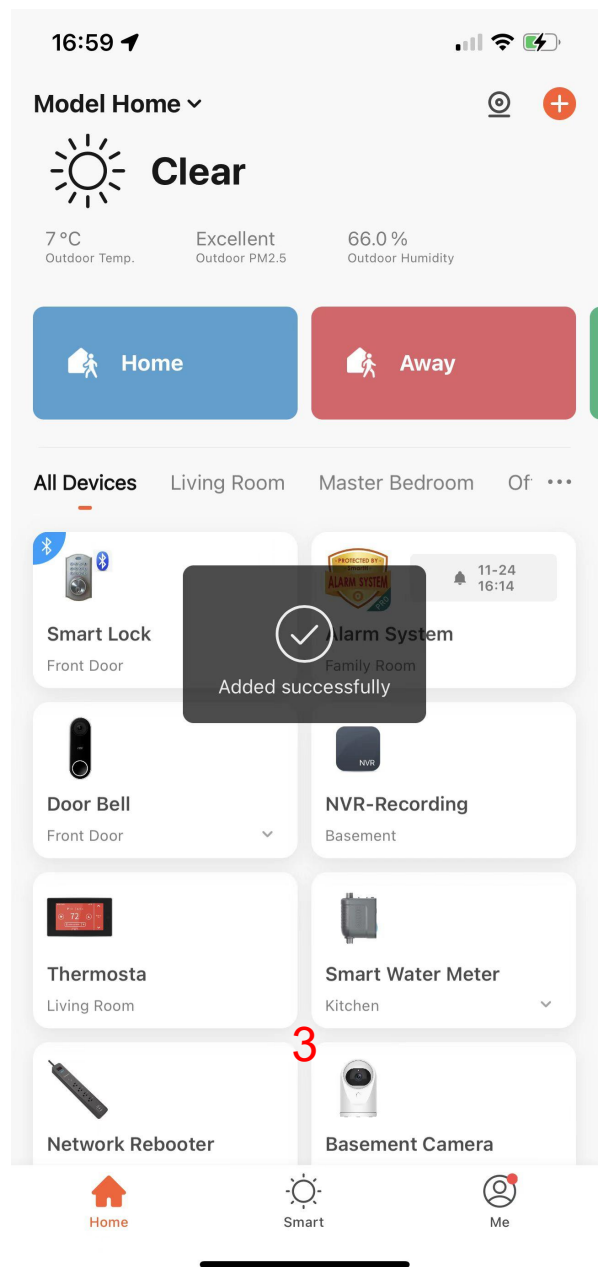
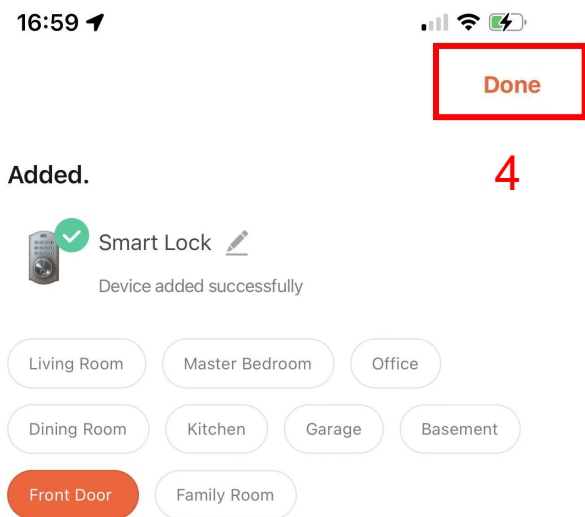

4. Tap “Done”

Now your Smart Lock is successfully added to MySmarth app.

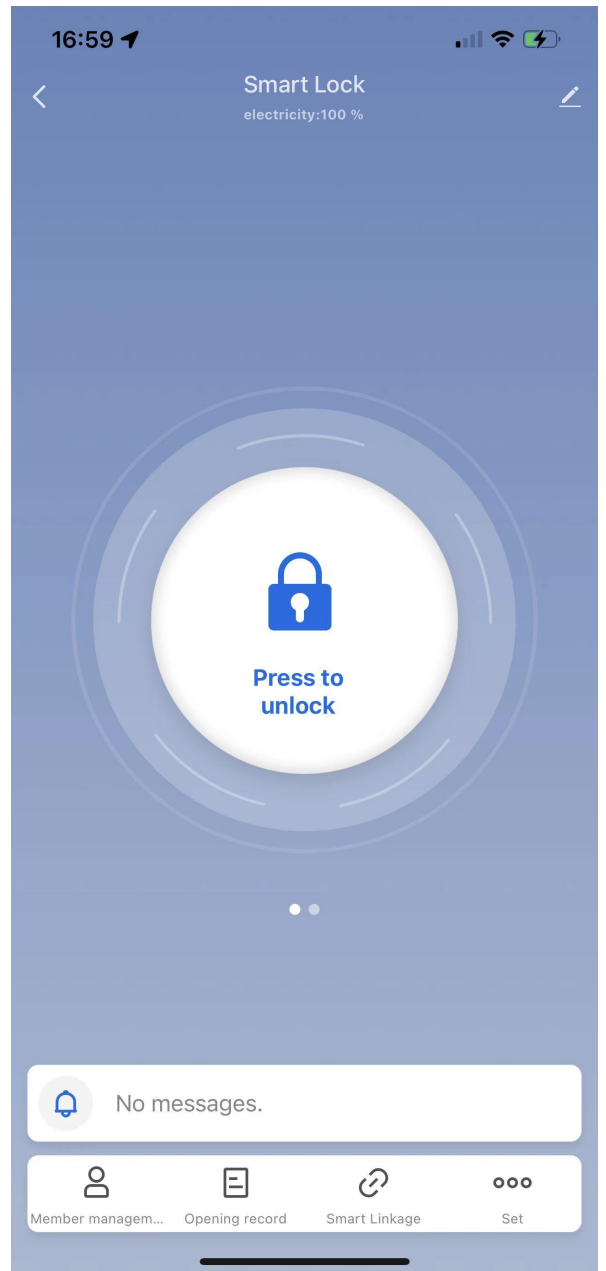
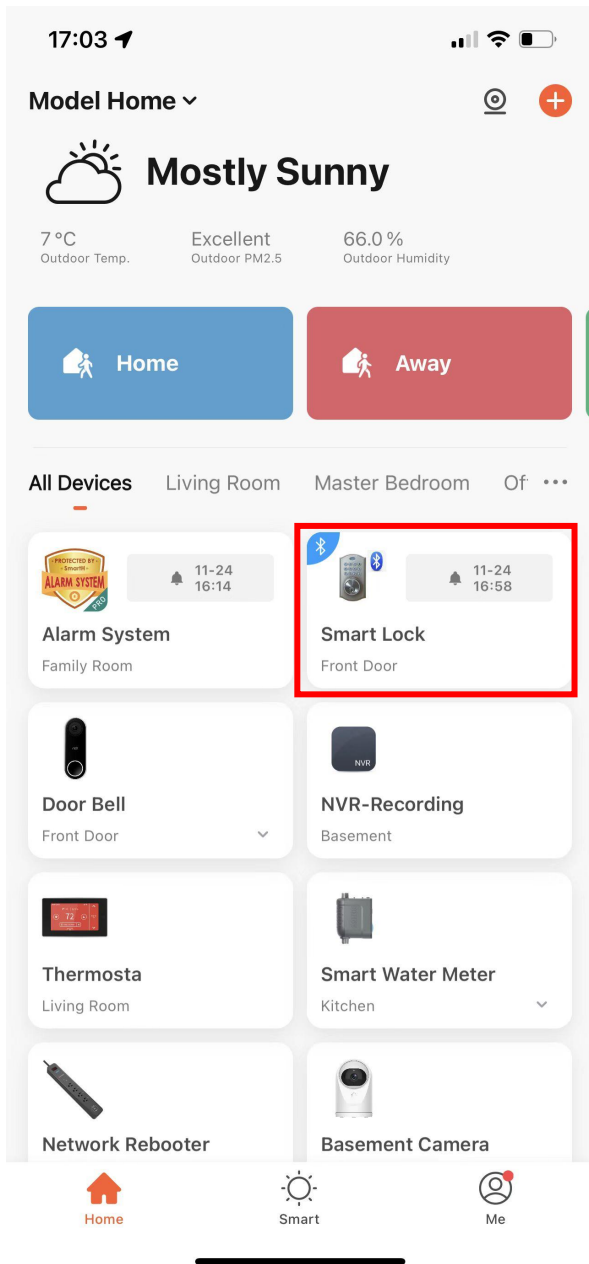

(Attention: the smart lock and the phone can only be allowed one-to-one connection at the same time. It means that if your phone is connecting with the smart lock, then the other phone can't connect the smart lock.)

How to set up a new Password

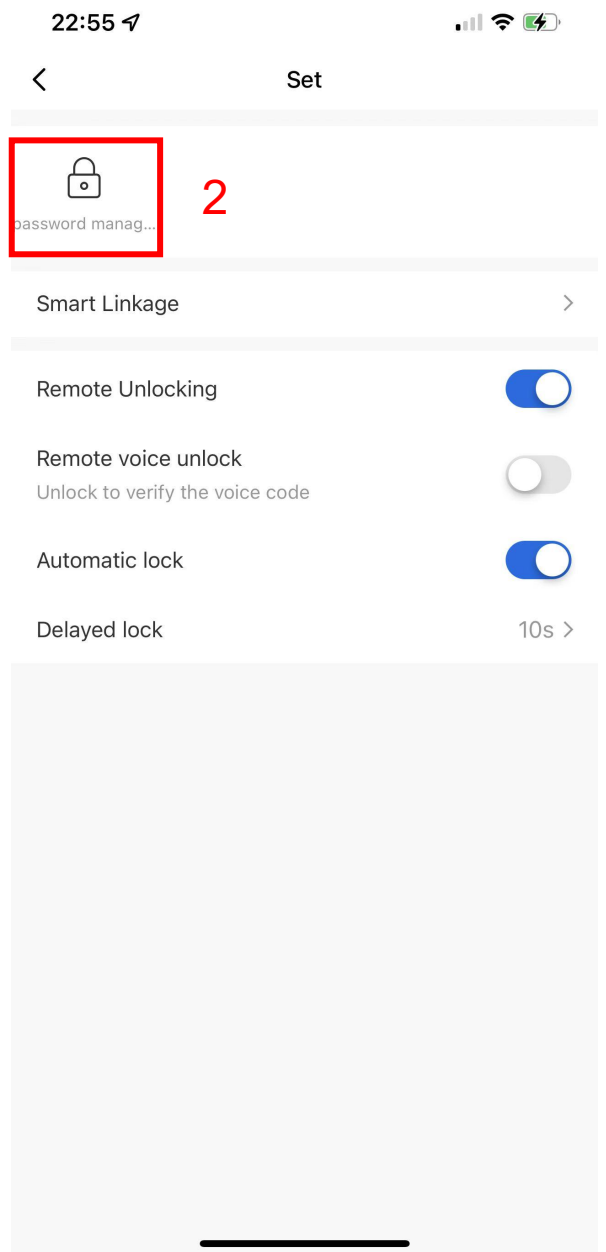
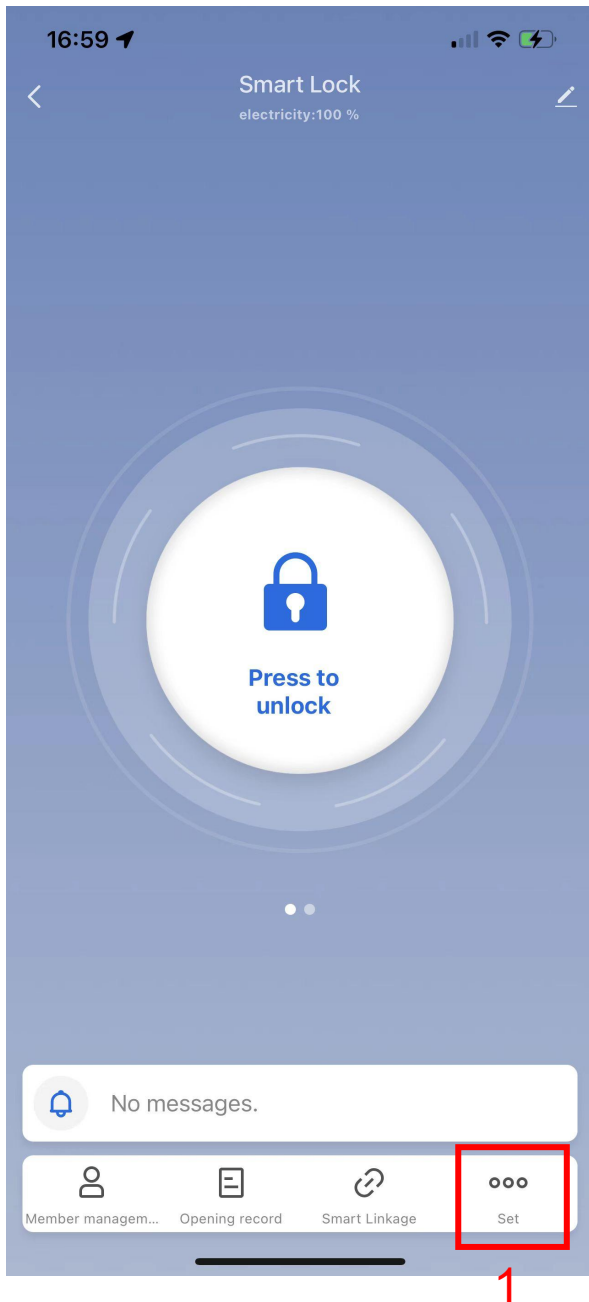

1. Click "SET"

2. Click "Password Management"

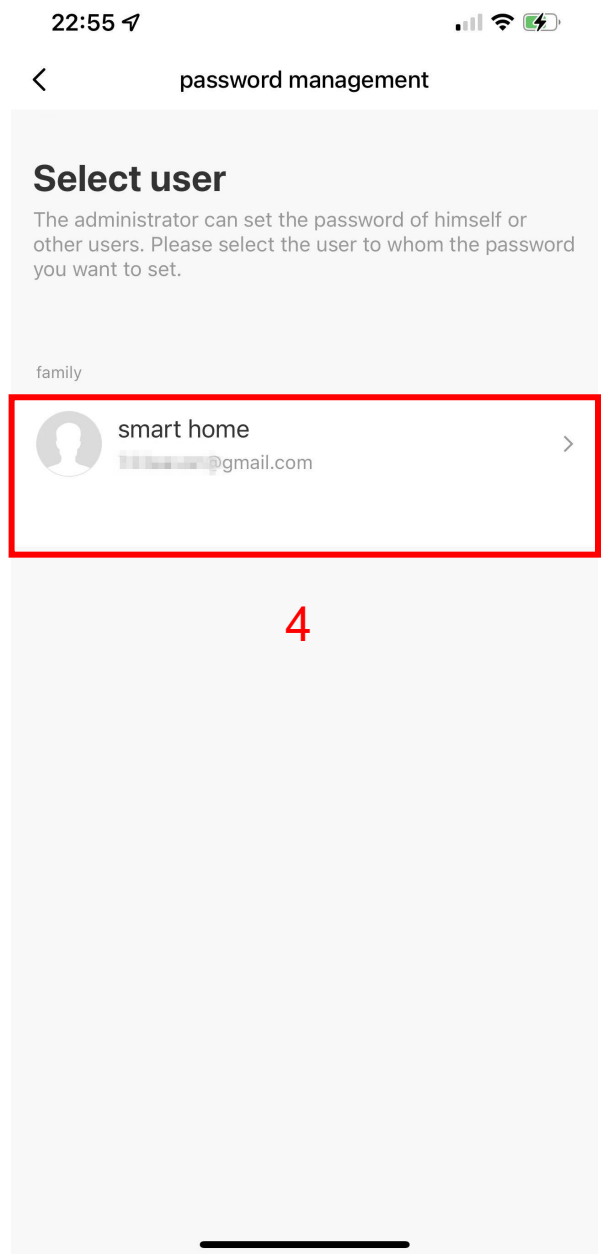
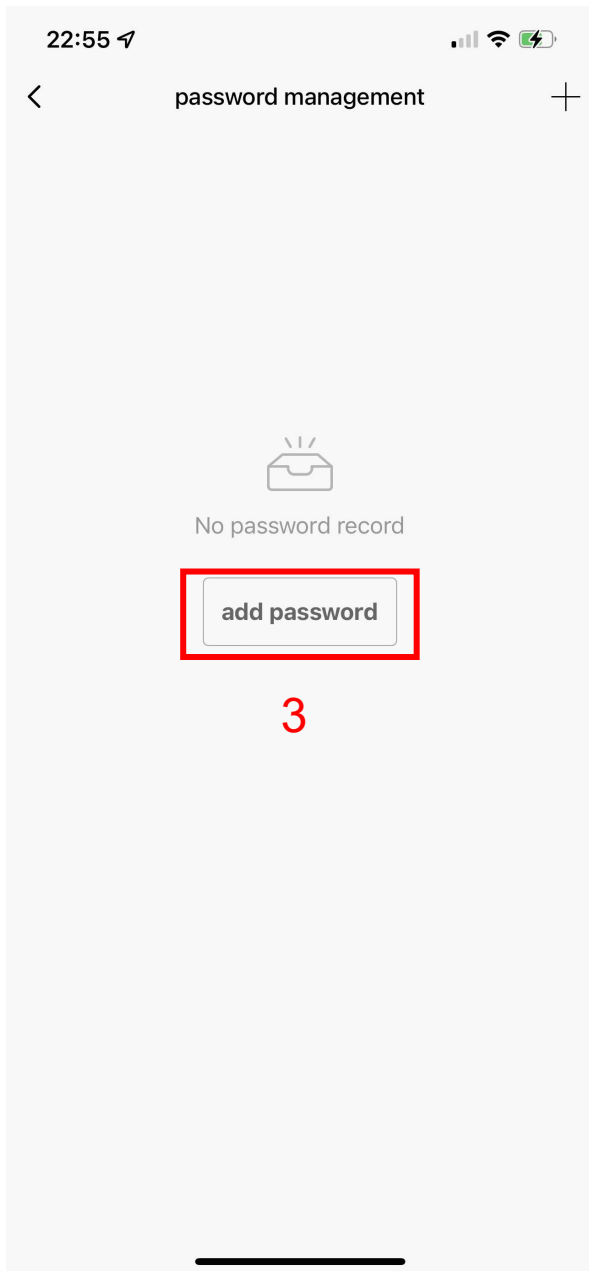

3. Click "add password"

4. Select "user"

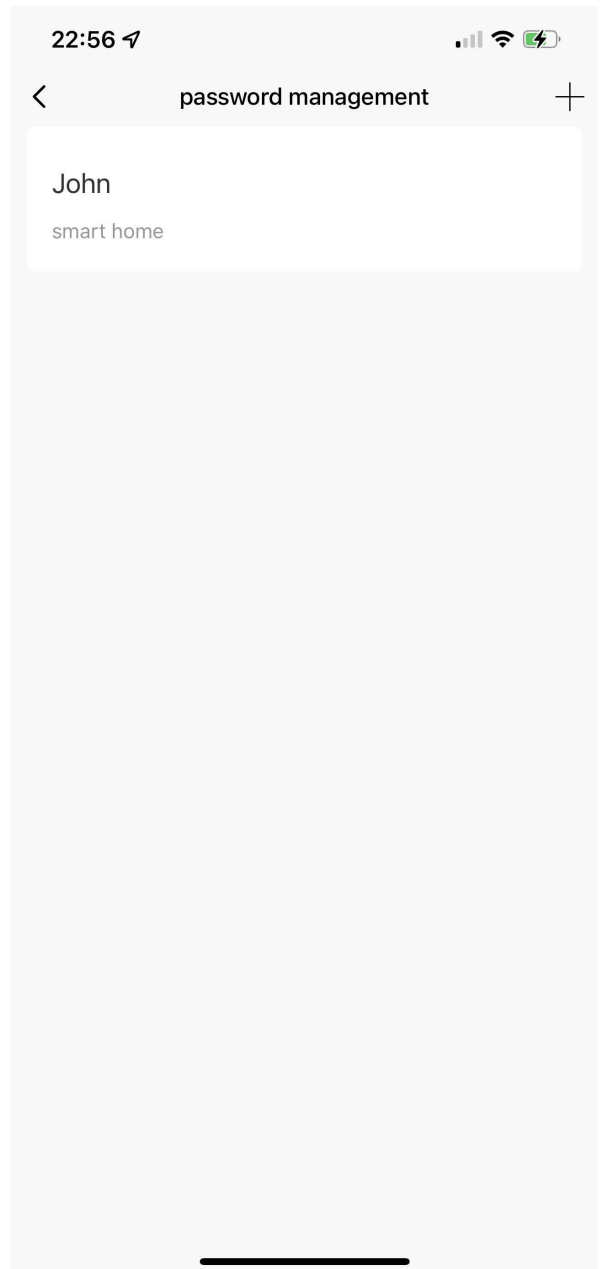
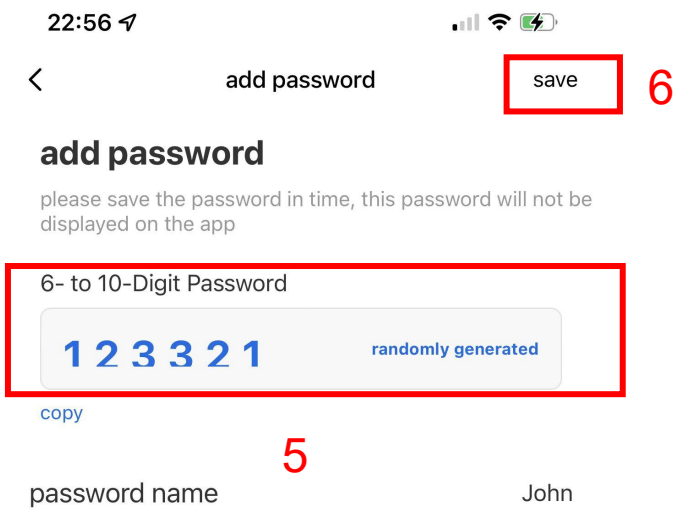

5. Enter a new password

6. Tap “save” and Now you can unlock with the new password

APP unlock

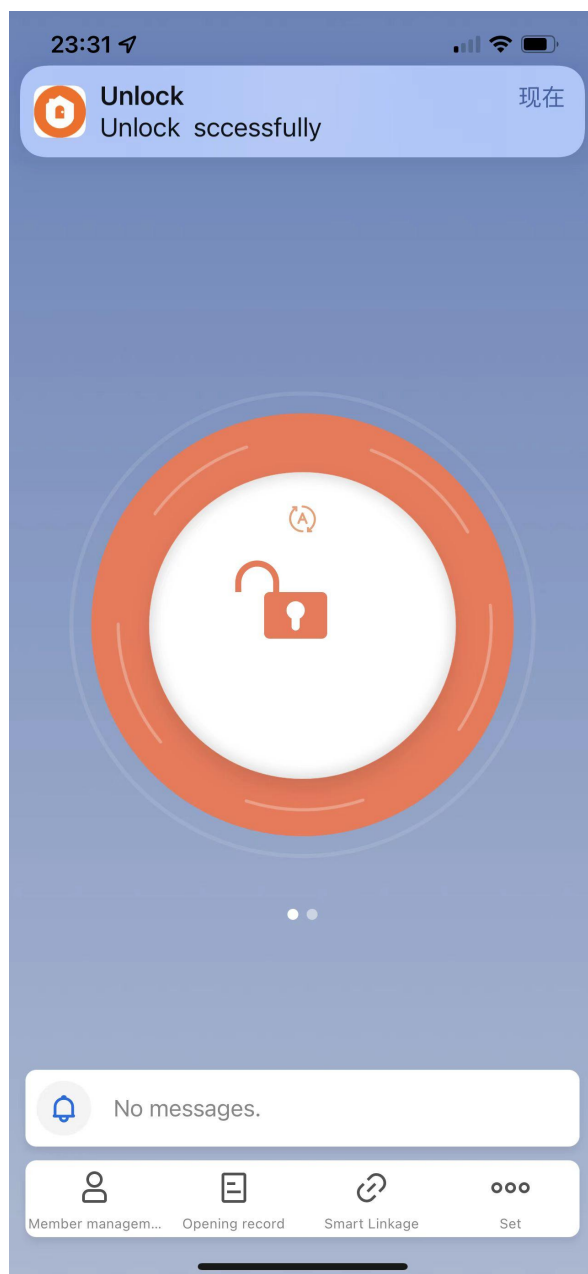
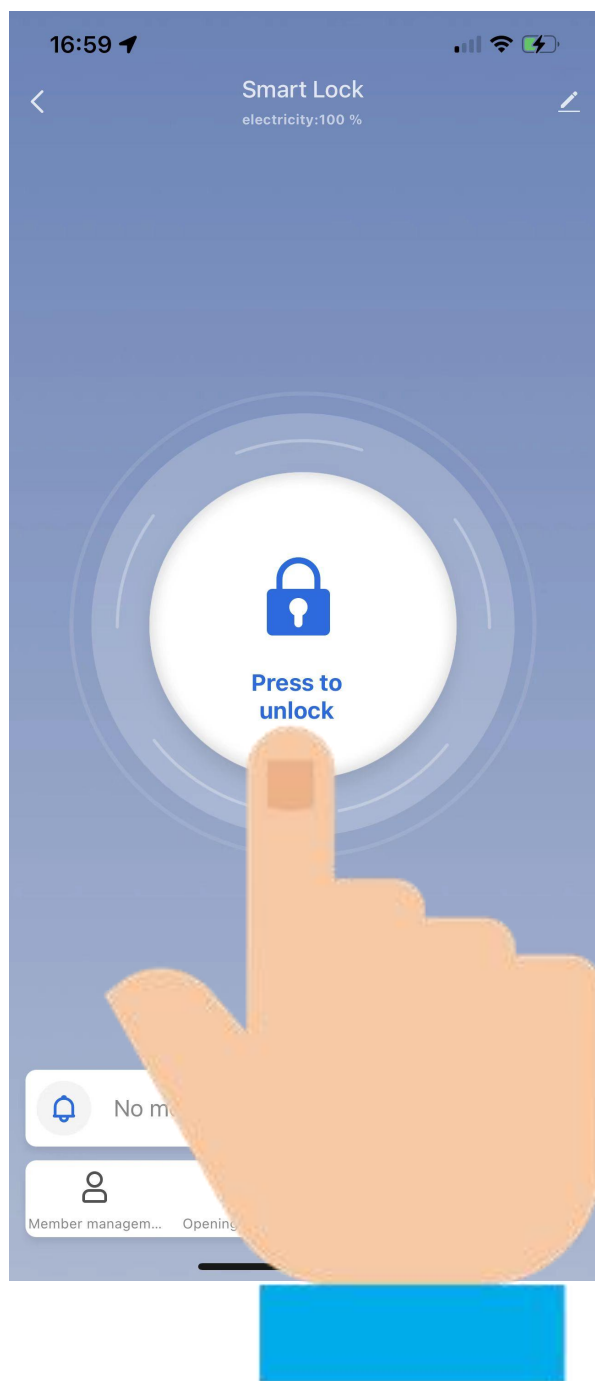

Long press the unlock key

Dynamic code unlock

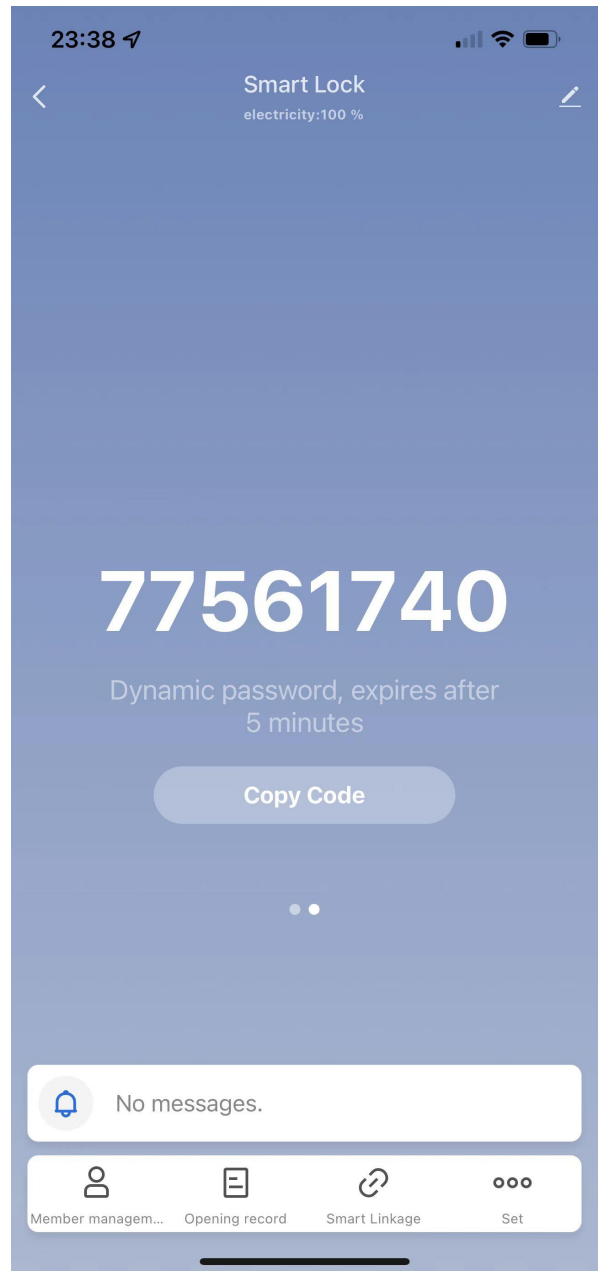
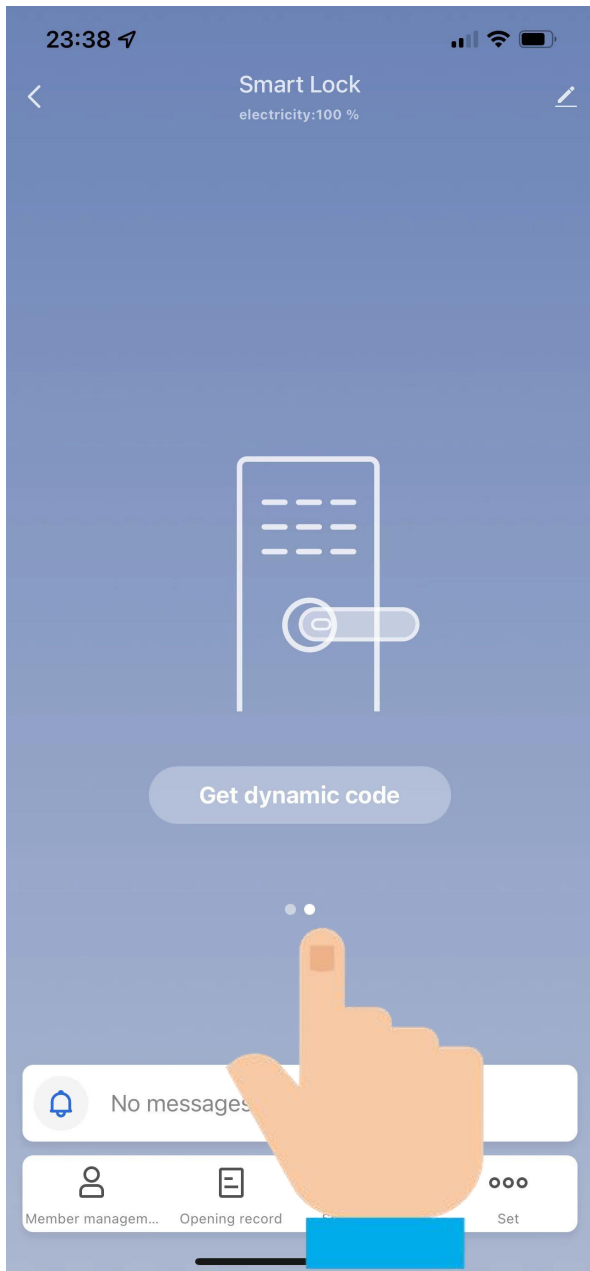

Get Dynamic Code

Copy Code

Paste and send via email or SMS

How to set up a Temporary Code

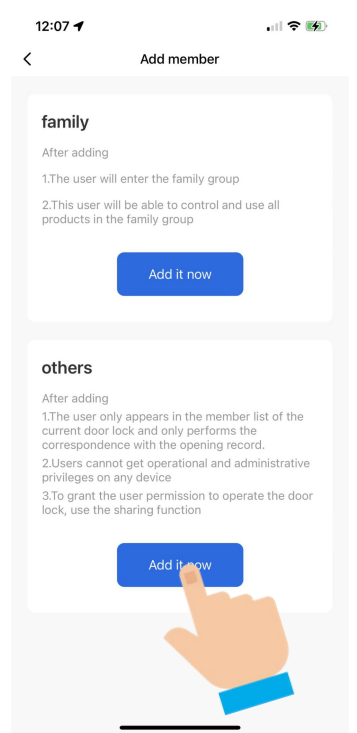
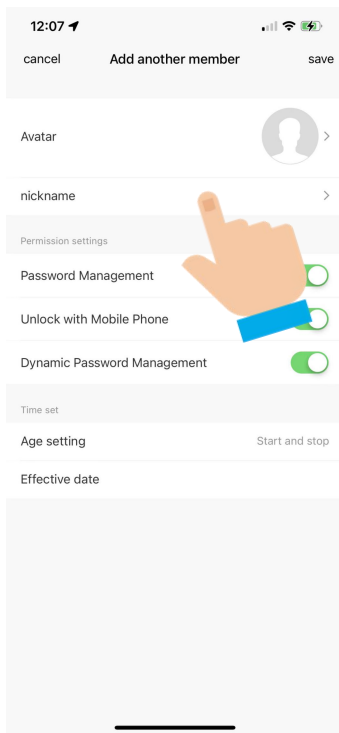
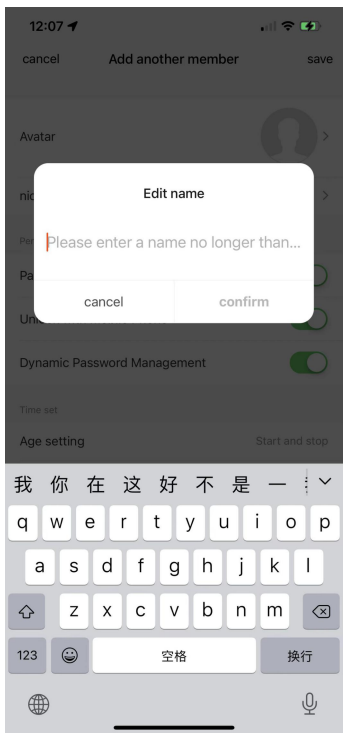
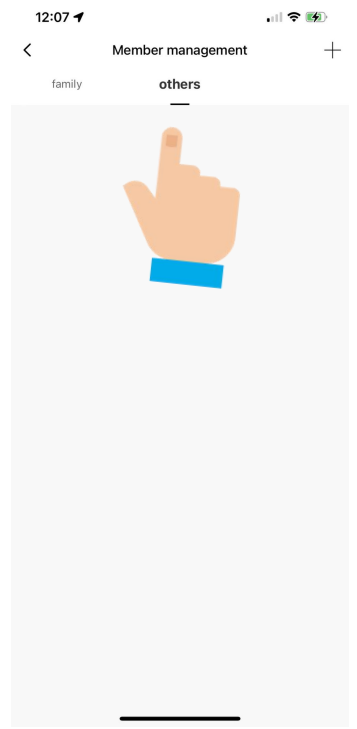
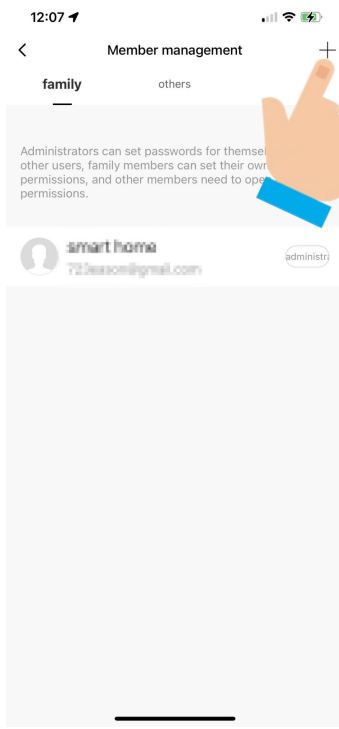
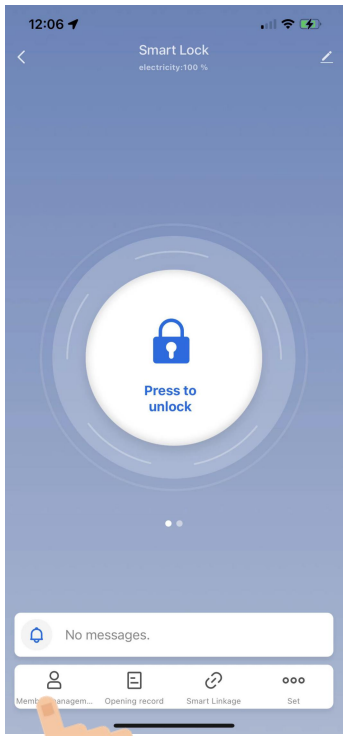

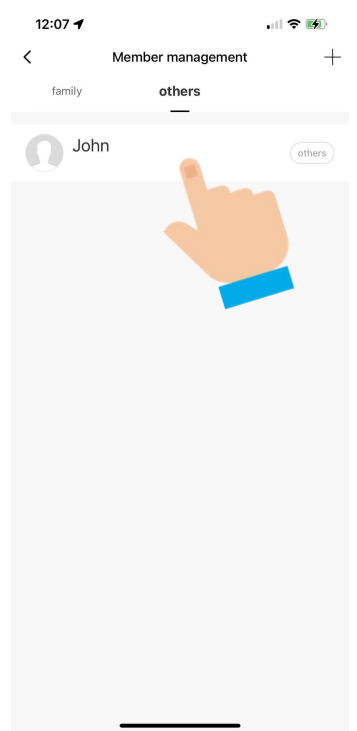
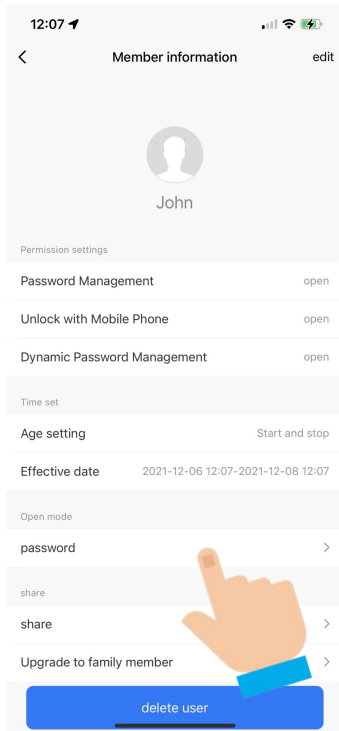
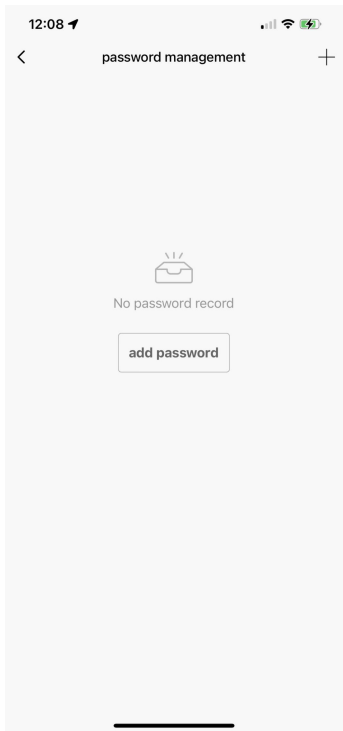
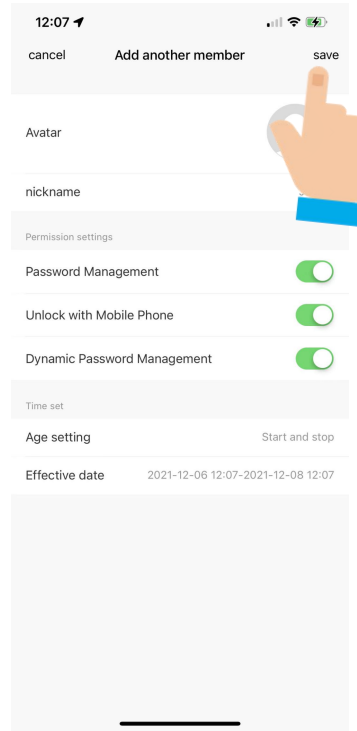
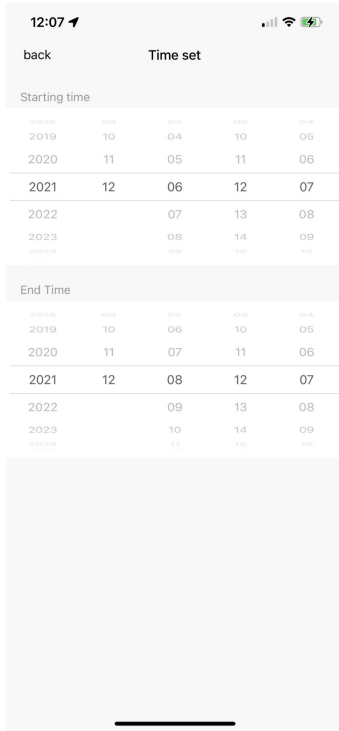
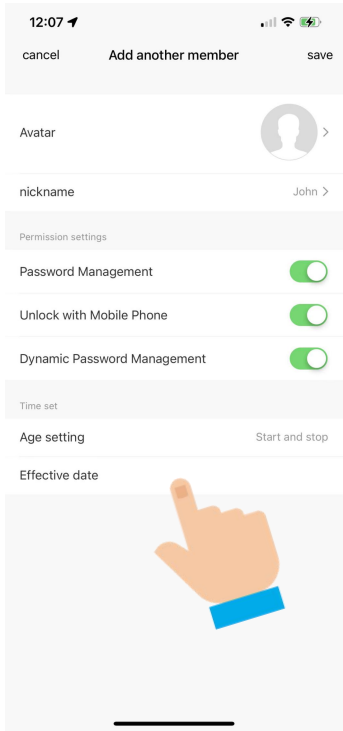

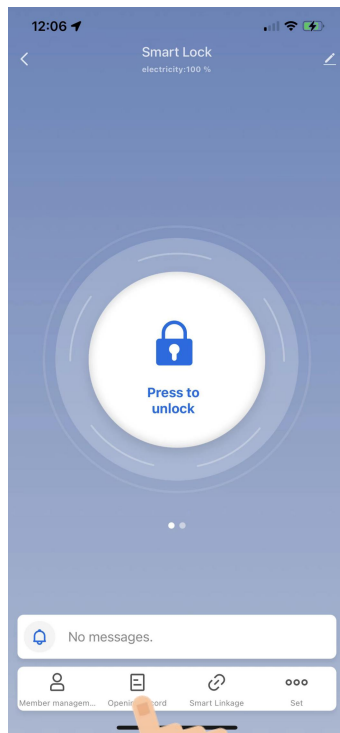
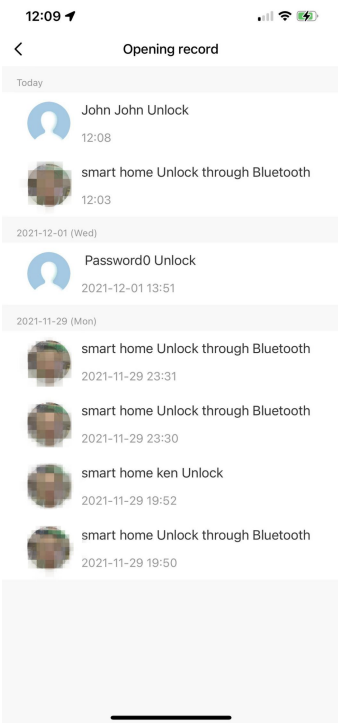
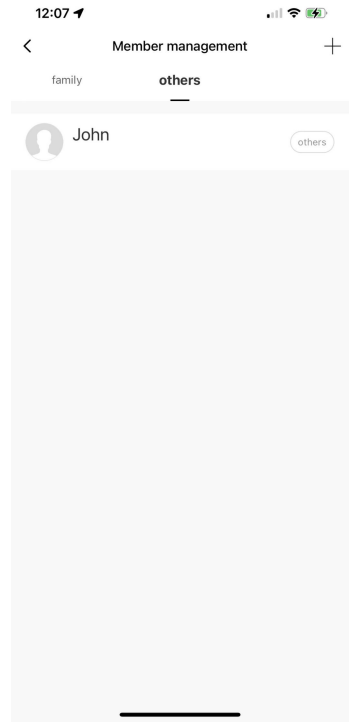
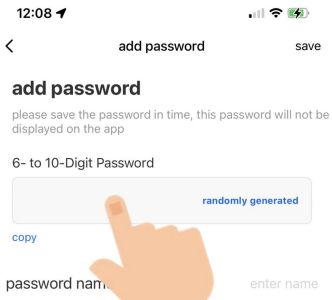

WARRANTY

Read the following terms and conditions carefully before using the SmartH Product. By using the SmartH Product, you consent to be bound by the terms and conditions of this Limited Warranty. IF YOU DO NOT AGREE TO THE TERMS AND CONDITIONS OF THIS WARRANTY, YOU SHOULD RETURN THE PRODUCT FOR A REFUND PRIOR TO USING IT.

SMARTH ONE(1) YEAR LIMITED WARRANTY

SmartH warrants to the Purchaser that SmartH Products will be free from electronic and Mechanical defects under normal use for one (1) year from the date of purchase, as long as said Purchaser occupies the residential premises upon which the Product was originally installed ("Warranty Period"). This Electronic and Mechanical Limited Warranty applies only to Products that were purchased from SmartH or a SmartH authorized seller, unless otherwise prohibited by law. SmartH Products are legitimately sold only by authorized sellers who are required to follow SmartH policies, procedures, and quality control standards. SmartH reserves the right to reject warranty claims from purchasers for Products purchased from unauthorized sellers, including unauthorized Internet sites. If your SmartH product should prove to be defective within the warranty period, we will repair it or replace it if necessary. For warranty purposes, please keep your original receipt for the duration of the limited warranty.

Exclusions for Warranty

Conditions that are not covered by these warranties include:

- 1) Any SmartH Product which has been damaged as a result of installation contrary to any of SmartH written installation instructions is not covered by these warranties.
 - 2) Any SmartH Product which has been modified by any non-Smarth component is not covered by these warranties.
 - 3) Any SmartH product that is used in combination with knobs, trim or levers of other than those manufactured by SmartH and designated for use with the applicable locks is not covered by these warranties
 - 4) Any consumable parts, such as batteries or protective coatings, that due to their nature diminish over time, unless failure has occurred due to a defect in materials or workmanship, nor to any cosmetic damage unless failure has occurred due to a defect in materials or workmanship.
 - 5) Any SmartH Product having a defect due to use of paints, solvents, or other chemicals is not covered by these warranties.
 - 6) Any SmartH Product having a defect caused by neglect, misuse, abuse or unreasonable or extraordinary use or maintenance, including use in a commercial application, is not covered by these warranties.
 - 7) Any SmartH Product that was purchased from an unauthorized seller is not covered by these warranties.
 - 8) ANY SOFTWARE THAT WAS DAMAGED OR NEEDS TO BE REPLACED DUE TO THE FAILURE OF THE SMARTH PRODUCT OR ANY DATA THAT IS LOST AS A RESULT OF THE FAILURE OR THE RESTORATION OF DATA OR RECORDS, OR THE REINSTALLATION OF SOFTWARE.
- These warranties are not transferable. Therefore, no transferee is covered by these warranties.

Warranty Claims

If you wish to make a warranty claim based upon a Product defect, please call us at 905-999-6660 or contact us at SUPPORT@SMARTH.CA

Please note that you will be required to provide a description of any claimed defect(s) and a dated receipt or other proof of purchase from SMARTH or the SMARTH authorized seller, to verify warranty eligibility.

Certain claimed defect(s) covered by these warranties may be resolved by SMARTH providing you with troubleshooting steps.

Other claimed defect(s) covered by these warranties may require Product replacement. Products may not be returned to SMARTH without prior authorization from SMARTH.

Remedies

For certain claimed defect(s) covered by these warranties, as determined by SMARTH, SMARTH will provide you with troubleshooting steps.

For other claimed defect(s) covered by these warranties, as determined by SMARTH, SMARTH will replace the defective Product or part.

If a SMARTH Product, which is the same as the SMARTH Product or any part covered by these warranties, has been discontinued at the time of replacement or if SMARTH determines, in its sole discretion, that such replacement is inappropriate, SMARTH reserves the right to substitute an alternative product. SMARTH also reserves the right to accept or reject an alternative product proposed as a replacement, when the value is higher than that of the Product originally purchased by the Purchaser. Except as expressly provided in these warranties to the contrary, SMARTH SHALL NOT BE OBLIGATED OR LIABLE FOR LABOR OR OTHER COSTS RELATED TO INSTALLATION, REPAIR OR REPLACEMENT OF A SMARTH PRODUCT, OR FOR LOSS OF, OR DAMAGE TO ANY MATERIAL WHICH IS NOT SOLD BY SMARTH.

For more detail Warranty Policy, please refer to <https://smarth.ca/service-agreement>

SUPPORT

If you encounter any issues, please contact us at :support@smarth.ca for help.

To explore our full selections of products, visit us at :WWW.Smarth.ca

Phone number :905-999-6660