

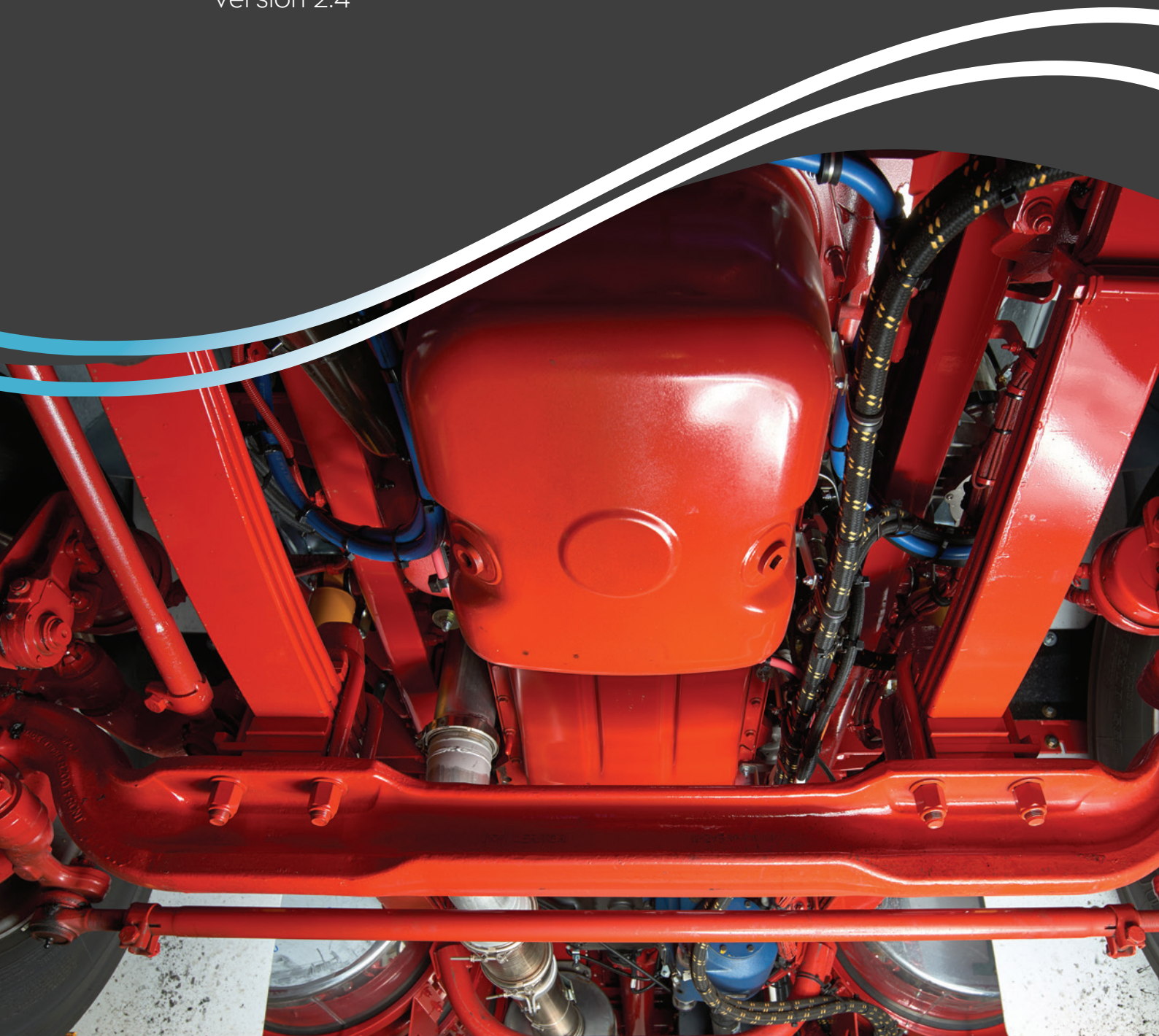

# National Heavy Vehicle Inspection Manual

Version 2.4





## Acknowledgements

The National Heavy Vehicle Regulator (NHVR) would like to thank the following organisations for contributing to the review and updating of Version 2 of the National Heavy Vehicle Inspection Manual.

- Access Canberra, ACT
- Australian New Zealand Policing Advisory Agency (ANZPAA)
- Australian Road Transport Suppliers Association (ARTSA)
- Australian Trucking Association (ATA)
- Bus Industry Confederation (BIC)
- Commercial Vehicle Industry Association of Australia (CVIAA)
- Department of Infrastructure, Energy and Resources, TAS
- Department of Planning, Transport and Infrastructure, SA
- Department of Transport, NT
- Department of Transport and Main Roads, QLD
- Heavy Vehicle Industry Australia (HVIA)
- National Road Transport Association (NatRoad)
- Roads and Maritime Services, NSW
- Truck Industry Council (TIC)
- VicRoads, VIC
- Victorian Automobile Chamber of Commerce (VACC)

The NHVR would also like to thank the following businesses for providing some of the diagrams and images displayed in this manual.

- Brisbane RVs
- Brown and Hurley Group
- Jost Australia
- Kangaroo Bus Lines

## Copyright

© National Heavy Vehicle Regulator (2020)  
Version 2.4 February 2020



<http://creativecommons.org/licenses/by-sa/3.0/au>

This work is licensed under a Creative Commons Attribution-ShareAlike 3.0 Australia Licence.  
To attribute this material, cite National Heavy Vehicle Regulator, National Heavy Vehicle Inspection Manual.  
Please **note**: While every attempt has been made to ensure the accuracy of the content of the National Heavy Vehicle Inspection Manual, it should not be relied upon as legal advice.





# Contents

## **Introduction**

## **Heavy Vehicle Inspection Checklist**

## **Heavy Trailer Inspection Checklist**

## **Section 1 Vehicle Identification**

## **Section 2 Brakes**

## **Section 3 Couplings**

Additional Information – Safety Chains

## **Section 4 Steering and Suspension**

Additional Information – Shock Absorber Leakage and Misting

## **Section 5 Wheels, Tyres and Hubs**

Additional Information – Retreaded Tyres

## **Section 6 Structure and Body Condition**

Additional Information – Mudguard and Mudflap Requirements

Additional Information – Rust and Corrosion

## **Section 7 Seats and Seatbelts**

Additional Information – ADR Occupant Restraint Requirements

## **Section 8 Lights and Reflectors**

Additional Information – Headlight Testing Screens

## **Section 9 Mirrors**

## **Section 10 Windscreens and Windows**

Additional Information – Replacing or Repairing Windscreens

## **Section 11 Engine, Driveline and Exhaust**

## **Section 12 LPG, NG and Hydrogen and Electric Vehicles**

## **Section 13 Buses**

## **Section 14 Trailers**

Additional Information – Safety Chains

Additional Information – Mudguard and Mudflap Requirements

Additional Information – Rust and Corrosion

## **Section 15 Motorhomes, Caravans and Campervans**

## **Section 16 Vehicle Dimensions**

## **Appendix A – Vehicle Category Codes and ADR Applicability Tables**

## **Appendix B – Vehicle Modifications**



# Introduction

The National Heavy Vehicle Inspection Manual (NHVIM) has been revised by the National Heavy Vehicle Regulator (NHVR) as part of its task to develop and introduce a single national approach to ensuring heavy vehicle roadworthiness. The NHVIM applies to all vehicles that have a gross vehicle mass (GVM) or aggregate trailer mass (ATM) greater than 4.5 tonnes.

The aim of the NHVIM is to provide consistent criteria for when a vehicle should fail a heavy vehicle inspection. The NHVIM details practical information about wear, damage or change to important systems regarding vehicle in-service inspections for owners, operators and administrators in each state and territory.

For a vehicle to be considered roadworthy it must comply with the *Heavy Vehicle (Vehicle Standards) National Regulation* (known as Vehicle Standards), and the relevant Australian Design Rules (ADRs). These contain mandatory requirements for the safe design, construction and maintenance of vehicles and for the control of emissions and noise. Relevant legislation as applicable in each jurisdiction should also be checked for requirements (e.g. specific regulations for passenger transport vehicles).

When using the NHVIM, the following principles are relevant:

- Equipment required by the Vehicle Standards or ADRs to be part of a vehicle must be present and work properly
- Equipment which is essential for compulsory components to function, the safe operation of a vehicle, or the control of its emissions, must be kept in good condition

- Equipment that is not required by the Vehicle Standards and has no direct effect on the vehicle's safe operation or the control of its emissions does not have to function, as long as it does not interfere with compulsory equipment that is required
- Manufacturers' recommendations relevant to the safety of particular vehicle parts or to the control of emissions must be considered
- Test methods or other conditions have not been specified except where they are necessary to determine whether criteria are met
- Examiners will utilise their trade qualifications and experience in vehicle repairs and maintenance and refer to any relevant information regarding vehicle manufacturer's specifications to ensure that the vehicle meets the requirements of the Vehicle Standards or ADRs.

Some inspection processes and standards apply only to certain heavy vehicles. Similarly, a heavy vehicle may have been exempted from a Vehicle Standard, dimension or ADR<sup>1</sup>.

Relevant ADRs are noted at the beginning of each section of the NHVIM. Some of the ADRs may have been repealed or updated since publication of the NHVIM, however, depending on the age of the vehicle being inspected, the ADR or aspects of the ADR may still be applicable. All relevant documents should be consulted for a complete list of the requirements.

<sup>1</sup>An ADR, *Heavy Vehicle (Vehicle Standards) National Regulation* or *Heavy Vehicle (Mass, Dimension and Loading) National Regulation* developed after publication of the NHVIM may allow a variation or exemption.





## Purpose

The purpose of the NHVIM is to provide authorised officers (including transport inspectors and police) and approved vehicle examiners (AVEs) with a nationally consistent set of failure criteria to be applied when conducting a heavy vehicle inspection.

## Scope

The NHVIM will provide guidance to Authorised Officers and AVEs on the national failure criteria for heavy vehicle roadworthiness.

The NHVIM is intended to apply to in-service heavy vehicles. Where heavy vehicles have been modified, Authorised Officers and AVEs will need to assess the vehicle against whatever approvals have been issued for the heavy vehicle in question. These may be in the form of an engineer's report, a Vehicle Standards exemption, a second stage manufacturer identification plate or a modification plate or label which signifies that the modifications have been carried out to an accepted standard.

The NHVIM will be supplemented by administrative processes and procedures.

The NHVIM at present does not cater for some vehicle considerations such as smart braking. The NHVR has included these types of considerations into a forward work program for consideration in future revisions to the NHVIM.

For the present, authorised officers and AVEs will be requested to refer to the original manufacturer specifications in the absence of failure criteria.

It is important to note that the Vehicle Standards, including the ADRs and the original heavy vehicle manufacturer's specifications take precedence over the requirements of the NHVIM.

## Objectives

The use of the same failure criteria in all jurisdictions for heavy vehicle inspections will ensure a more consistent approach to the management and detection of vehicles which are unsafe.

As a general rule the application of consistent failure criteria will prevent duplication of effort within and between jurisdictions and through mutual recognition lead to a more efficient transfer of heavy vehicles between states and territories.

## Consultation

The failure criteria set out in the NHVIM reflect current consultation with road user groups, road transport authorities, police agencies, manufacturers and suppliers. The NHVR seeks to continually update and improve the NHVIM. Contributions and feedback may be made by sending an email to [vehiclestandards@nhvr.gov.au](mailto:vehiclestandards@nhvr.gov.au)

# Heavy Vehicle Inspection Checklist

This checklist has been provided as a guide to the types of information that may need to be collected, or components that need to be inspected, during a vehicle inspection. This checklist is not a reason for rejection.

Vehicle Identification	
<input type="checkbox"/> Registration Number	<input type="checkbox"/> VIN/Chassis Number
<input type="checkbox"/> Compliance Plate	<input type="checkbox"/> Seating Capacity
<input type="checkbox"/> Make/Model	<input type="checkbox"/> Body Type
<input type="checkbox"/> Main Body Colour	<input type="checkbox"/> Engine Number
<input type="checkbox"/> Cylinders	<input type="checkbox"/> Odometer Reading (where fitted)
Brakes	
<input type="checkbox"/> Brake Components	<input type="checkbox"/> Air/Vacuum System (including trailer breakaway protection)
<input type="checkbox"/> Service Brake	<input type="checkbox"/> Park Brake
Couplings	
<input type="checkbox"/> Fifth Wheel/Ballrace	<input type="checkbox"/> Pin Couplings/Pintle Hooks
<input type="checkbox"/> Towbar	<input type="checkbox"/> Towing Attachments
<input type="checkbox"/> Safety Chains/Cable Attachments	
Steering and Suspension	
<input type="checkbox"/> Steering Wheel	<input type="checkbox"/> Free Play
<input type="checkbox"/> Arms/Linkages/Components	<input type="checkbox"/> Steering Box/Pump
<input type="checkbox"/> Shock Absorbers	<input type="checkbox"/> Air Bag/Spring/Coil
Wheels, Tyres and Hubs	
<input type="checkbox"/> Wheels/Rims	<input type="checkbox"/> Wheel Nuts/Fasteners
<input type="checkbox"/> Tyres	<input type="checkbox"/> Hubs
<input type="checkbox"/> Wheel Bearings	
Structure and Body Condition	
<input type="checkbox"/> Body Panels/Fittings	<input type="checkbox"/> Body and Mounting
<input type="checkbox"/> Mudguards	<input type="checkbox"/> Mudflaps
<input type="checkbox"/> Rear marking plates (as per VSB12)	<input type="checkbox"/> Cabin/Body Condition
<input type="checkbox"/> Number Plates	<input type="checkbox"/> Front Underrun Protection
<input type="checkbox"/> Electrical Equipment	<input type="checkbox"/> Horn
<input type="checkbox"/> Chassis	



# Heavy Vehicle Inspection Checklist (cont.)

## Seats and Seatbelts

- |                                                     |                                    |
|-----------------------------------------------------|------------------------------------|
| <input type="checkbox"/> Seats                      | <input type="checkbox"/> Seatbelts |
| <input type="checkbox"/> Child Restraint Anchorages |                                    |

## Lights and Reflectors

- |                                                       |                                                                           |
|-------------------------------------------------------|---------------------------------------------------------------------------|
| <input type="checkbox"/> Headlights (high/low beam)   | <input type="checkbox"/> Fog Lights                                       |
| <input type="checkbox"/> Front Position Light         | <input type="checkbox"/> Daytime Running Lights                           |
| <input type="checkbox"/> Direction Indicator Lights   | <input type="checkbox"/> Clearance/End Outline Marker Lights (front/rear) |
| <input type="checkbox"/> Reflectors (front/side/rear) | <input type="checkbox"/> Brake Lights                                     |
| <input type="checkbox"/> Tail Lights                  | <input type="checkbox"/> Reversing Lights                                 |
| <input type="checkbox"/> Number Plate Light           | <input type="checkbox"/> Side Marker Lights                               |

## Mirrors

- Rear View Mirror(s)

## Windscreen and Windows

- |                                  |                                                   |
|----------------------------------|---------------------------------------------------|
| <input type="checkbox"/> Glazing | <input type="checkbox"/> Wipers/Demisters/Washers |
| <input type="checkbox"/> Windows |                                                   |

## Engine, Driveline and Exhaust

- |                                           |                                                              |
|-------------------------------------------|--------------------------------------------------------------|
| <input type="checkbox"/> Exhaust System   | <input type="checkbox"/> Noise Emissions                     |
| <input type="checkbox"/> Engine/Driveline | <input type="checkbox"/> Gearbox/Differential/Power Steering |
| <input type="checkbox"/> Fuel Tank        | <input type="checkbox"/> Oil Leaks                           |

## LPG and NG Vehicles

- |                                                  |                                                     |
|--------------------------------------------------|-----------------------------------------------------|
| <input type="checkbox"/> LPG/NG Compliance Plate | <input type="checkbox"/> LPG/NG Number Plate Labels |
| <input type="checkbox"/> Container               |                                                     |

## Buses

- |                                            |                                                                  |
|--------------------------------------------|------------------------------------------------------------------|
| <input type="checkbox"/> Fire Extinguisher | <input type="checkbox"/> School Bus Warning System (if required) |
| <input type="checkbox"/> Entrances/Exits   | <input type="checkbox"/> Emergency Exits/Signs                   |
| <input type="checkbox"/> Doors/Steps       | <input type="checkbox"/> Guard Rails                             |

## Motorhomes, Caravans and Campervans

- |                                                        |                                          |
|--------------------------------------------------------|------------------------------------------|
| <input type="checkbox"/> Fire Extinguisher             | <input type="checkbox"/> Sleeping Berths |
| <input type="checkbox"/> Cooking Facilities            | <input type="checkbox"/> Doors           |
| <input type="checkbox"/> Toilets/Urinals>Showers/Sinks | <input type="checkbox"/> Ventilation     |
| <input type="checkbox"/> Electrical/Gas Certification  |                                          |

# Heavy Trailer Inspection Checklist

This checklist has been provided as a guide to the types of information that may need to be collected, or components that need to be inspected, during a vehicle inspection. This checklist is not a reason for rejection.

Vehicle Identification	
<input type="checkbox"/> Registration Number	<input type="checkbox"/> VIN/Chassis Number
<input type="checkbox"/> Compliance Plate	<input type="checkbox"/> ATM
<input type="checkbox"/> Make/Model	<input type="checkbox"/> Body Type
<input type="checkbox"/> Main Body Colour	
Brakes	
<input type="checkbox"/> Brake Components	<input type="checkbox"/> Breakaway Protection
<input type="checkbox"/> Service Brake	<input type="checkbox"/> Park Brake
<input type="checkbox"/> Brake Connections	
Couplings	
<input type="checkbox"/> Drawbar	<input type="checkbox"/> Towing Attachments
<input type="checkbox"/> Skid Plates	<input type="checkbox"/> Kingpin
<input type="checkbox"/> Safety Chains	
Steering and Suspension	
<input type="checkbox"/> Axles	<input type="checkbox"/> Springs/Air Bags
<input type="checkbox"/> Hangers	<input type="checkbox"/> Pins
<input type="checkbox"/> Bushes	<input type="checkbox"/> Shock Absorbers
Wheels, Tyres and Hubs	
<input type="checkbox"/> Wheels/Rims	<input type="checkbox"/> Wheel Nuts/Fasteners
<input type="checkbox"/> Tyres	<input type="checkbox"/> Hubs
<input type="checkbox"/> Wheel Bearings	
Structure and Body Condition	
<input type="checkbox"/> Mudguards	<input type="checkbox"/> Mudflaps
<input type="checkbox"/> Chassis/Sub-frame	<input type="checkbox"/> Number Plate
<input type="checkbox"/> Rear marking plates (as per VSB12)	<input type="checkbox"/> Tray/Body Condition (if applicable)
Lights and Reflectors	
<input type="checkbox"/> Brake Lights	<input type="checkbox"/> Direction Indicator Lights
<input type="checkbox"/> Tail Lights	<input type="checkbox"/> Reversing Lights (optional)
<input type="checkbox"/> Reflectors (front/side/rear)	<input type="checkbox"/> Front Position Light
<input type="checkbox"/> Number Plate Light	<input type="checkbox"/> Clearance/End Outline Marker Lights (front/rear)
<input type="checkbox"/> Side Marker Lights	





## Section 1

# Vehicle Identification

### Objective:

To ensure that the vehicle being inspected is authentic and correctly identified.

Australian Design Rules relevant to this section:

ADR 61 Vehicle marking

**Note:** Where a vehicle fails the identity inspection in this section, the Tiered Identity Inspection Regime of the jurisdiction should be applied or the matter referred to the police.

### 1.1 Check the identity of the vehicle

#### Reasons for rejection

- a) No VIN/chassis number present

**Note:** A chassis number is the identifying number of a vehicle that was built prior to 1 July 1989. The number can be any combination of letters or numbers and can be any length.

A VIN (Vehicle Identification Number) is the unique identifying number of a vehicle that was built from 1 July 1989. The number can be any combination of letters and numbers (excluding the letters i, o and q) and must be 17 digits in length.

- b) VIN on identification (compliance) plate differs from that stamped into body or chassis

**Note:** Second edition ADR vehicles may have a chassis number stamped into the chassis that is different to the chassis number on the vehicle plate. Provided that one of the chassis numbers stamped into the chassis matches the vehicle plate, this is not a reason for rejection.

- c) VIN/chassis number has been altered or tampered with  
d) Engine number has been altered or tampered with

- e) No engine number present  
f) A motor vehicle manufactured from 1 August 1972 that is not fitted with an Australian identification (compliance) plate and has not been previously registered in Australia  
g) A trailer manufactured from 1 August 1984 that is not fitted with an Australian identification (compliance) plate and has not been previously registered in Australia  
**Note:** Where a motor vehicle or trailer mentioned in (f) or (g) is not fitted with an identification plate, but proof of previous registration in Australia is provided, this is not a reason for rejection.  
h) For a vehicle that is used in a road train or B-double combination, the vehicle plate does not include the words "ROAD TRAIN" and/or "B-DOUBLE"; and for a trailer designed for use in a road train, the words "ROAD TRAIN TRAILER"  
i) For a vehicle that has been modified for use in a road train or B-double combination, the vehicle is not fitted with a modification plate certifying it to code S8 (Road Train Prime Mover), S9 (B-double Prime Mover) or S11 (Road Train Trailer) of VSB6.







## Section 2

# Brakes

### Objective:

To ensure that the brakes operate effectively and are correctly adjusted.

### Australian Design Rules relevant to this section:

**ADR 35** Commercial vehicle brake systems

**ADR 38** Trailer brake systems

**ADR 42** General safety requirements

**ADR 64** Heavy goods vehicles designed for use in road trains and B-doubles

### 2.1 Check brake components

#### Reasons for rejection

- a) Brake pedals do not have an anti-slip surface across the complete surface
- b) Brake pedals or handles are broken, missing or are outside the scope of manufacturer's original design
- c) Brake control mountings, pivots, cables or links are kinked, missing, loose, broken, excessively worn or binding
- d) Vehicle is not equipped with an effective mechanical park brake
- e) The locking device on a park brake handle or lever is missing or not operational
- f) Park brake control is not designed to minimise risk of inadvertent release (e.g. requiring two separate or distinct movements)
- g) Abrasions or cuts on brake hoses penetrate further than the outer protective covering
- h) Brake pipes, hoses and connections are not securely mounted, or are cracked, broken, kinked, crimped, damaged by heat, or have visible signs of leakage, swelling or bulging
- i) Air reservoirs in the vehicle's braking system do not have an automatic or manual condensate drain valve at the lowest point of each air brake reservoir  
**Note:** Automatic condensation drain valves must have a means to allow water from the compressed air reserve to be drained manually.
- j) Brake drums or discs are not fitted or have missing pieces, or cracks other than short heat cracks inside the drums or in the disc

- k) Brake pad or shoe material does not come in full contact with brake disc or drum friction surface, excluding any crowning

**Note:** Brake pad or shoe material should not protrude from the drum by more than 3mm.

- l) Drums or discs are worn beyond manufacturer's specifications
- m) Any caliper, wheel cylinder or master cylinder leaks
- n) Friction material of the linings or pads are contaminated with oil, grease, brake fluid or another substance that will reduce the friction coefficient of the friction material
- o) The thickness of the linings or pads is less than the manufacturer's recommended minimum. If this is not known or is no longer appropriate, the thickness of the linings or pads is less than the following:
- the rivet or bolt head on riveted or bolted linings or
  - within 3mm of the friction material mounting surface on bonded pads or linings.
- p) Brake chambers (including chamber clamps) or camshaft support brackets are loose, bent, cracked or missing
- q) Brake linings or pads are missing, broken or loose on their shoes or plates
- r) Brake components such as springs, anchor pins, cam rollers or bushes, pull or push rods, clevis pins, retainers or brake chamber mounting bolts are missing, loose, damaged or broken

**Note:** It is acceptable to have small cracks, blemishes or blisters that do not affect the way the friction materials are attached or its contact with friction surfaces.

- s) In the case of hydraulic, or air-over-hydraulic brakes, the reservoirs, master cylinders or servo units are loose, cracked, broken, or excessively worn or are damaged so that leaks are likely
- t) Vehicles equipped with Antilock Braking Systems (ABS) where the antilock system warning light is inoperative or indicates a system fault or is missing
- u) In the case of hydraulic, or air-over-hydraulic brakes, the fluid level in a master cylinder reservoir is below the minimum level.

Figure 2.1 Drum and disc brake components

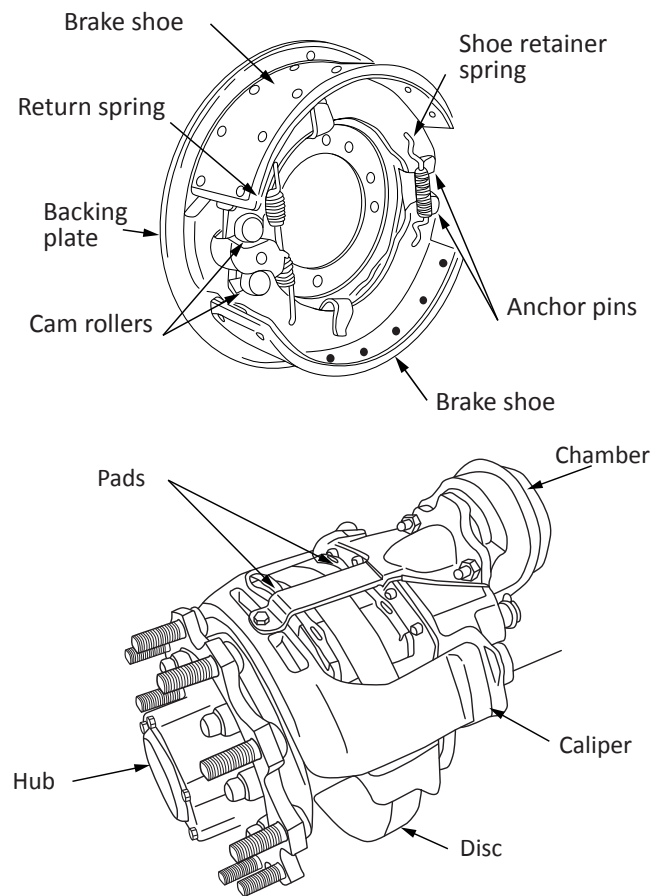

## 2.2 Check brake adjustment

### Reasons for rejection

- a) With any brake fully applied, a brake adjustment indicator runs out of travel or indicates that adjustment is necessary
- b) Brake chamber push or pull rods move more than the brake component manufacturers recommendation or where this is unavailable, 80% of their maximum stroke when the brakes are fully applied

Further information on long stroke brake chambers can be sought from the brake component manufacturers or industry advisory documents.

- c) With any brake fully applied, any stroke indicator displays evidence of excessive stroke (known as over-stroking)

Figure 2.2 Example of excessive stroke/over-stroking

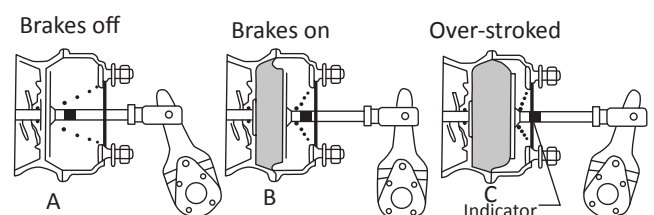



**Note:** Not all push and pull rods will have a stroke indicator.

*Not all automatic slack adjusters which travel past 90 degrees are considered over-stroked.*

*Further information on slack adjusters can be sought from the brake component manufacturers or industry advisory documents.*

- d) The park brake and/or emergency brake is not capable of being fully applied without the control running out of available travel
- e) The brake adjusters are bent, damaged or excessively worn, or are not properly adjusted.

### 2.3 Check air compressor/vacuum pump

#### Reasons for rejection

- a) The air compressor or vacuum pump has loose mounting bolts, cracked or broken mounting brackets, braces or adaptors, or is inoperative
- b) Drive pulleys are cracked, broken or loose
- c) Drive belts are loose, cracked through to reinforcing plies, extensively frayed or missing drive sections
- d) For vehicles fitted with compressed air brakes, the air compressor does not build up air pressure to at least 80% of the vehicle's governor cut-out pressure in five minutes after the compressed air reserve is fully used up.

### 2.4 Check air filters

#### Reason for rejection

- a) Any filter units for air compressors or vacuum pumps are not fitted, or are loose, blocked or damaged.

### 2.5 Check braking system operation

#### Reasons for rejection

- a) Any brake failure indicators do not operate
- b) Any brake air or vacuum storage system is not fitted with a visual or audible warning device to warn the driver, whilst seated in the normal driving position, of a lack of air pressure or vacuum
- c) Any compulsory pressure, vacuum or low level warning devices or gauges do not operate
- d) The brake controls do not cause the corresponding brake to apply when they are operated (with the engine running if necessary).

### 2.6 Check vacuum assisted brake system integrity

#### Reasons for rejection

- a) With vacuum depleted from the system and with moderate steady force applied, the brake pedal does not travel towards the floor when the engine is started
- b) With the engine stopped, one application of the service brake with a moderate pedal force results in the low vacuum indicator coming on
- c) If a trailer is connected to the motor vehicle, the trailer vacuum brakes cannot be applied from the normal driving position
- d) A brake pedal that is held depressed while the engine is running, tends to rise when the engine is stopped
- e) Vehicle is not fitted with at least one vacuum storage reservoir or tank
- f) The reservoir or tank for vacuum is not protected by a check valve
- g) Vacuum is not available as soon as the engine starts, or build up time to reach the low vacuum mark (to deactivate the warning device) is longer than 30 seconds
- h) Time taken for vacuum to reach normal working level when the vacuum reserve is fully depleted is longer than 60 seconds
- i) The vacuum warning device (if fitted) does not deactivate when the low vacuum mark is reached
- j) The loss of vacuum from its maximum indicated level exceeds 125mm Hg in 10 minutes when the engine is stopped
- k) With the engine stopped and vacuum at its maximum indicated level, the vacuum gauge reading does not fall progressively with every application of the service brake
- l) With the engine stopped, there is insufficient level of vacuum to allow at least two assisted service brake applications.

### 2.7 Check air brake system integrity (including air over hydraulic)

These checks require the assistance of another person to operate the vehicle controls.

Use chocks to prevent accidental movement of the vehicle.

Observe manufacturer's shut-down instructions before switching off the engine (e.g. to avoid turbo-charger damage).

#### Reasons for rejection

- a) A visual or audible warning device connected to the brake system does not provide a warning to the driver when the

- air pressure is lowered to less than the following levels, unless the manufacturer specifies a different level:
- 65% of average operating pressure or
  - 420kPa (60psi) for ADR 35 vehicles, or
  - 300kPa (45psi) for pre-ADR 35 vehicles.
- b) The cut-out pressure is more than 1120kPa (160psi), or less than 720kPa (100psi) unless other values are recommended by the manufacturer
- c) The governor cut-in pressure is less than 550kPa (80psi), unless another value is recommended by the manufacturer
- d) With the brake system fully charged, the engine stopped and the service brake applied, the air brake pressure drops more than 20kPa (3psi) per minute. An additional drop per minute of 5kPa is allowed for each trailer that may be attached
- e) With the engine stopped and the service brake released, the air brake pressure drops more than 15kPa per minute. An additional drop per minute of 5kPa is allowed for each trailer that may be attached
- f) With the brake system fully charged and the engine stopped, five applications of the service brakes results in the reservoir pressure dropping to less than 50% of the maximum value
- g) Spring brakes (if fitted) activate before the low pressure warning device activates
- h) The parking brake is inoperative or on a vehicle with a reserve air tank is unable to be released at least once
- i) Air reservoir drain valves are inoperative
- j) Excessive oil drains from the reservoir (this usually indicates a faulty compressor)
- k) Where a pressure protection valve is fitted, the valve is damaged or broken
- l) For a motor vehicle built from 1 July 1998 and designed to tow a trailer, the air supply to the trailer is not automatically stopped when at least one of the prime mover circuits drops below 420kPa or when the trailer is disconnected

**Note:** *Although it is usually a sign of neglected brake maintenance, excessive water in a reservoir is not a reason for rejection, provided that it is fully drained during the check.*

*When performing a dynamic emergency brake test, care is to be taken not to damage components (e.g. tail shaft mounted emergency brakes).*

- m) Where ADR 35 applies, when the air-pressure in one (and only one) sub-circuit is fully drained any brake connected to the other sub-circuit fails to operate when the service brake is applied

- n) Where ADR 35 applies, spring brakes (if fitted) apply when one sub-circuit is fully drained.

**Note:** *ADR 35 and UNECE Regulation 13 both require brake tests to be conducted with the engine running.*

*For certain vehicles spring brakes may apply if the engine is not running and the service brake circuit has been fully depleted of air.*

*In a single circuit service brake system, energy to hold off spring brakes is supplied by a separate dedicated reservoir.*

*In a dual circuit service brake system, spring brakes are normally held off by residual line pressure. Repeated applications of the service brake will cause the spring brakes to apply, which is acceptable.*

*Some vehicles may have an alternative test procedure. If the vehicle fails the procedures outlined here, advice from the manufacturer may be required.*

## 2.8 Check hydraulic brake system integrity

### Reasons for rejection

- a) When a constant force is applied to the brake pedal for 10 seconds:
- after the initial travel, the service brake pedal travels to the floor, or
  - the brake system failure indicator comes on.
- b) When the service brakes are firmly applied, less than 20% of the pedal travel remains (unless the brake system is designed for greater travel)
- c) When soft pumping makes the brake pedal travel to the floor.

### NOTE on Brake testing

**Sections 2.9, 2.12, 2.13 and 2.16** detail various ways of testing brake performance. Vehicles need not be tested against each of these methods. Consult your local authority to determine when a brake test is required and for guidance on which test to perform.

## 2.9 Service brake test with a decelerometer

Decelerometer standards should be read in conjunction with the equipment manufacturer's instructions.

On some vehicles with light axle loads, or when testing in wet weather, it might be difficult to obtain a brake test result because of wheel lockup. In these cases the pedal pressure should be reduced to a point where only the minimum specified deceleration rates are achieved.

Set up a suitable decelerometer in the vehicle cabin. Drive the vehicle to a speed of at least 35km/h. If the vehicle has a manual transmission, put the transmission into neutral; automatic transmission vehicles may remain in gear. With hands on the steering wheel, bring the vehicle to a halt as



rapidly as possible in a safe manner with one sustained and smooth application of the service brakes.

#### Reasons for rejection

- The application of the brakes causes the vehicle to swerve from a straight line path
- The service braking system decelerates the vehicle at less than the performance requirement specified in Table 2.1
- Individual wheel locking cannot be controlled.

**Table 2.1** Service brake performance

Type of vehicle	Average		Peak	
	m/s <sup>2</sup>	%g	m/s <sup>2</sup>	%g
GVM exceeding 4.5 tonnes	2.8	29	4.4	45

**Note:** ‘Average’ is the average deceleration recorded over the test. This is not an averaging of peak decelerations recorded during the test. ‘Peak’ is the maximum deceleration recorded during the test.

### 2.10 Emergency brake test with a decelerometer

Emergency brakes are required to be fitted to vehicles not designed to ADR 35 or vehicles not fitted with a tandem master cylinder/dual circuit brakes.

**Note:** An emergency brake means a brake designed to be used if the vehicle’s service brake fails. Generally these are found on vehicles built prior to 1980.

To test the emergency brakes with a decelerometer, install the decelerometer, drive the vehicle to a speed of at least 35km/h. If the vehicle has a manual transmission, put the transmission into neutral; automatic transmission vehicles may remain in gear. Bring the vehicle to a halt as rapidly as possible in a safe manner with one sustained and smooth application of the emergency brake.

Hand brakes fitted to drive shaft or gearbox are not tested using this method, tests should instead be conducted to manufacturer’s specifications.

When performing a dynamic emergency brake test, either in accordance with the above method or the manufacturer’s specifications, care is to be taken not to damage components (e.g. tail shaft mounted emergency brakes).

#### Reason for rejection

- The emergency brake decelerates the vehicle at less than the performance requirement specified in Table 2.2.

**Table 2.2** Emergency brake performance

Type of vehicle	Average		Peak	
	m/s <sup>2</sup>	%g	m/s <sup>2</sup>	%g
GVM exceeding 4.5 tonnes	1.1	11	1.5	15

**Note:** ‘Average’ is the average deceleration recorded over the test. This is not an averaging of peak decelerations recorded during the test. ‘Peak’ is the maximum deceleration recorded during the test.

### 2.11 Parking brake test for vehicles designed to ADR 35

Parking brake test for vehicles designed to ADR 35 or vehicles fitted with tandem master cylinder/dual circuit brakes.

Apply the park brake and attempt to drive forward using a light throttle.

**Note:** A parking brake means the brake usually used to keep a vehicle stationary while the vehicle is parked.

#### Reason for rejection

- The parking brake does not provide any retardation.

### 2.12 Brake testing with a skid plate tester

This section should be read in conjunction with the equipment manufacturer’s instructions.

Using a skid plate tester, check the performance of the vehicle’s braking system in accordance with the manufacturer’s test procedure.

#### Reasons for rejection

- There is more than 30% difference in the brake performance between the wheels on the same axle
- The service braking system decelerates the vehicle at less than the performance requirements specified in Table 2.1
- In other than ADR 35 vehicles, or vehicles fitted with a tandem master cylinder/dual circuit brakes, the emergency brake decelerates the vehicle at less than the performance requirements specified in Table 2.2.

### 2.13 Brake testing with a roller brake tester

This section should be read in conjunction with the equipment manufacturer’s instructions and the National Roller Brake testing Procedure: [www.nhvr.gov.au/nrbt](http://www.nhvr.gov.au/nrbt)

Using a roller brake tester, check the performance of the vehicle’s braking system in accordance with the manufacturer’s test procedure.

Release all brakes, place transmission in neutral (not ‘park’ for automatic transmission) and slowly apply the service brake until maximum force is attained, or wheel slip occurs.

#### Reasons for rejection

- There is more than 30% difference in the brake performance between the wheels on the same axle
- The service braking system decelerates the vehicle at less than the performance requirements specified in Table 2.1

**Note:** On some vehicles the brake performance requirement might not be reached as the vehicle will be lifted out of the rollers or lock the wheels. Similarly, it might not be reached if a load proportioning valve is fitted to the axle group. In both cases it is considered a pass if the brake balance is within the specified limit.

- c) Any parking brake assembly that when applied does not give a reading, or the vehicle does not lift out of the rollers

**Note:** For park brakes that operate independently of the service brakes, care should be taken when performing roller brake testing. When testing using a brake roller is not possible, the parking brake should be tested in accordance with the manufacturer's testing procedures.

## 2.14 Check trailer brakes and breakaway protection

The examiner should seek the assistance of another person in order to make a thorough check of the breakaway protection.

### Reasons for rejection

- a) A truck trailer interconnecting flexible hose and coupling is not properly mated or secured
- b) The trailer brakes are not capable of being applied and released from the normal driving position
- c) For a towing vehicle that is configured to tow a trailer with air or vacuum assisted brakes, there is no visible or audible warning device to alert the driver of the towing vehicle, while the driver is in a normal driving position, of a lack of air or vacuum
- d) In an air operated brake system when any trailer hose coupling or connection is disconnected to simulate a breakaway situation, the rate of loss in air pressure in the towing vehicle's service brake system is more than 15kPa per minute after stabilisation.

**Note:** If an invasive inspection of brake components is necessary, it should be carried out in accordance with the procedure in Australian Standard AS 3617 Parameters for the machining and reconditioning of brake drums and discs.

## 2.15 Advanced Braking Systems

This section covers vehicles which have advanced braking systems such as anti-lock braking systems (ABS), electronic braking systems (EBS), electronic stability control (ESC), etc.

### Reasons for rejection

- a) An advanced braking system warning lamp:
  - is missing
  - does not illuminate as required when ignition is switched to the on position
  - indicates a fault with a system

- b) An advanced braking system component (wheel speed sensor, etc) is missing or damaged to an extent where it does not perform its intended function.
- c) Advanced braking system wiring or connectors are corroded, damaged, not insulated or are not securely fastened.
- d) Electrical wiring is located where it can:
  - become exposed to excessive heat
  - come into contact with moving part
- e) An advanced braking system component or system has been modified outside of manufacturer's specifications.
- f) A truck fitted with an advanced braking system is not fitted with a compliant ABS/EBS connector to attach an ABS/EBS equipped trailer.

## 2.16 Road testing of service brakes

Use a suitable level area with a hard level surface that is free from gravel or loose material and is at least 350 metres in length for testing of heavy vehicles. Drive the vehicle to 35km/h then put the transmission into neutral; automatic transmission vehicles may remain in gear. With both hands on the steering wheel bring the vehicle to a halt as rapidly as possible in a safe manner with one sustained and smooth application of the service brakes.

### Reasons for rejection

- a) The application of the brakes causes the vehicle to swerve from a straight line path
- b) For vehicles built after 1930, the service braking system fails to bring the vehicle to a stop within the distance specified in Table 2.3.

Table 2.3 Service brake stopping distance

Type of vehicle	Distance
GVM exceeding 4.5 tonnes	16.5 metres

**Note:** The maximum stopping distance in this table is intended to cover a wide range of vehicles including some older vehicles with older braking systems. If a modern vehicle is found to only just comply with the prescribed values then the owner should be informed that the brakes are likely to be in need of maintenance.

For vehicles built before 1930, no service brake performance requirements apply, but the on-road brake test should be conducted to assist in determining whether a brake maintenance problem exists. Such problems should be followed up by visual inspection of the brake components.

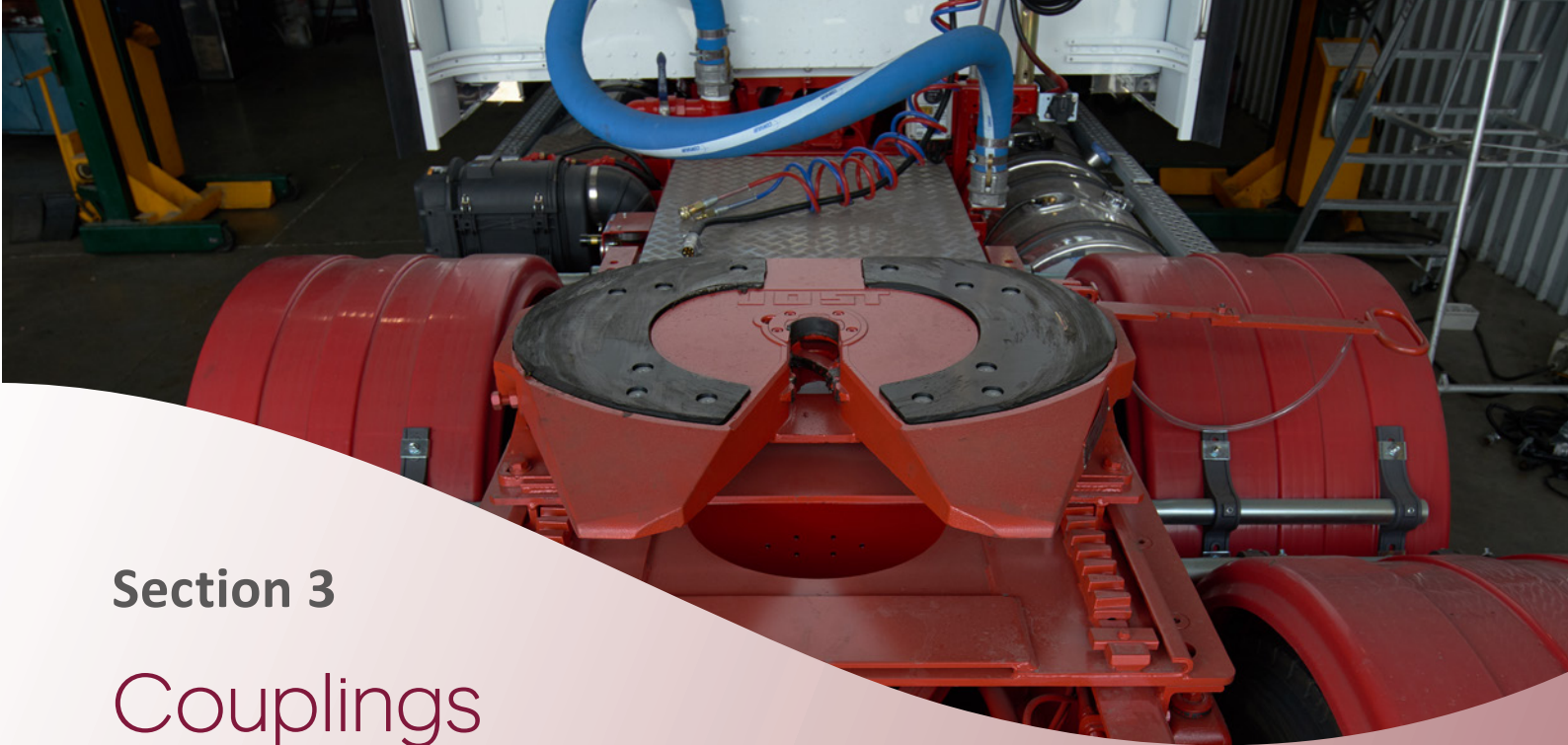

## Section 3

# Couplings

### Objective:

To ensure that all tow couplings and associated components are in a serviceable condition and that they provide the necessary load carrying capacity.

Australian Design Rules relevant to this section:

**ADR 62 Mechanical connections between vehicles**

**ADR 63 Trailers designed for use in road trains**

**Note:** This section should be read in conjunction with ADR 62, relevant Australian Standards and manufacturers' specifications for minimum requirements.

Installation of an aftermarket coupling is a modification. Please refer to Appendix B – Vehicle Modifications.

### 3.1 Check fifth wheels and turntables

In this section, the term 'fifth wheel' refers to the upper surface of the coupling that directly articulates with the skid plate of a semitrailer. A 'turntable' is the rotating part of the coupling mount that allows the fifth wheel to rotate, for example a ballrace.

#### Reasons for rejection

- The fifth wheel does not display the manufacturer's name/trademark, nominal size (e.g. 50mm) and the 'D-value' rating
  - The top and bottom mounting flanges have insufficient or ineffective fasteners
  - Fasteners either side of the mounting frame, plate or pivot brackets are insufficient or ineffective
  - Fifth wheel or turntable mounting plate or sub-frame assembly securing bolts are missing, broken or loose, or the fasteners are U-bolts
- Fifth wheel or turntable mounting plate or sub-frame assembly securing bolts are not ISO Class 8.8 (SAE Grade 5) or stronger
  - Fifth wheel or turntable mounting is not done in accordance with manufacturers' specifications, Australian Standards or VSB6 Section P2
  - There is movement between the fixed mounting components
  - There is more than 5mm horizontal movement between:
    - the pivot bracket pin and bracket, or
    - a slider bracket and slide base.
  - There are cracks in mounting angles or plates, pivot brackets, slider components or coupler plates except for casting shrinkage cracks
  - The fifth wheel pivot bracket pin/s or bushes are missing, insecure or worn beyond manufacturer's specifications

#### National Heavy Vehicle Regulator

1300 MYNHVR (1300 696 487) 7am to 5pm (AEST)  
Email [info@nhvr.gov.au](mailto:info@nhvr.gov.au) [www.nhvr.gov.au](http://www.nhvr.gov.au)



- k) The locking mechanism on either side of a sliding coupling is missing, inoperative or worn beyond manufacturer's specifications
- l) End stops on slides are missing or insecure
- m) Kingpin locking mechanism parts are missing, worn or adjusted beyond manufacturer's specifications, or damaged to the extent that the kingpin is not securely held
- n) The top and bottom plates, flanges and welds are loose, cracked, missing or broken
- o) Ball bearing type turntables are worn beyond the manufacturer's specifications, or to the extent that the upper and lower flanges or bearing halves touch each other or the ball bearings seize.

**Note:** The fifth wheel feet shall be secured to the base plate either using bolts or by welding. Bolting is preferred – welding is only permitted if the manufacturer recommends this method.

Trailer skid plates and kingpins are covered in Sections 14.5 and 14.6 of this manual.

Figure 3.1 Fixed base fifth wheel assembly

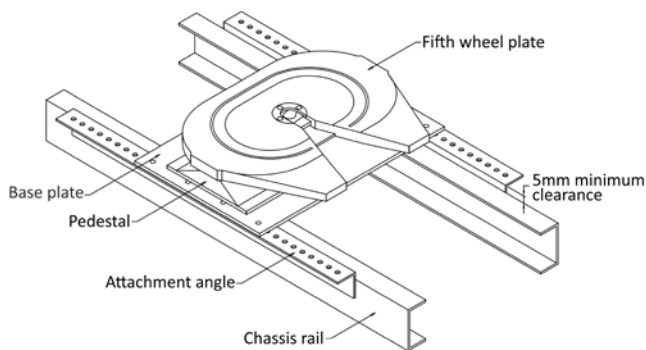
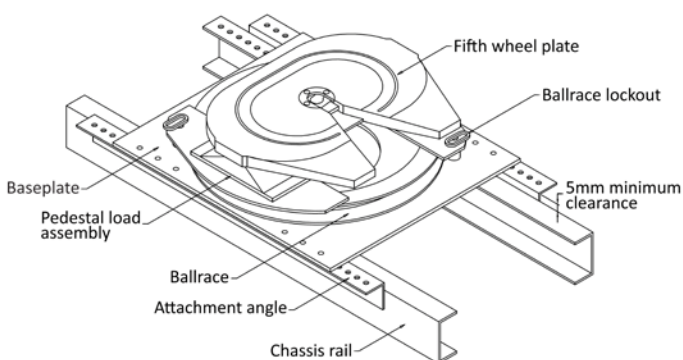

Figure 3.2 Ballrace base fifth wheel assembly



### 3.2 Check pin couplings and pintle hooks

#### Reasons for rejection

- a) Where ADR 62 applies, a 50mm pin type coupling does not display the manufacturer's name/trademark, rated vertical load and the 'D-value rating'
- b) The tow ball or hook assembly (127mm or hook type) is not legibly and indelibly marked with the manufacturer's name or trademark and the rated 'D-value'
- c) Deformed or cracked fasteners including welds
- d) Any mounting bolts, fasteners or weld beads have advanced corrosion
- e) The area that the pin coupling or pintle hook is mounted on is loose or cracked or any locking mechanism is not fitted or is inoperative
- f) The pin coupling or pintle hook welds have cracks
- g) Pin couplings or pintle hooks are worn beyond the manufacturer's limits. If the manufacturer's limits are not known, any dimension on a wear surface of the horn of a pintle hook or pin coupling is worn more than 5% of the original diameter (see Figure 3.3)

Figure 3.3 Typical tow devices

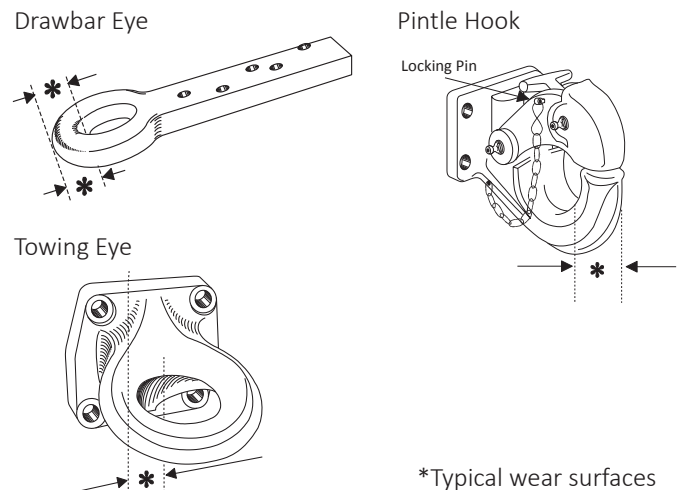

- h) Any wear on the diameters of each of the coupling pin and the drawbar eye bush greater than 1.5mm.

**Note:** Wear should be checked by direct measurement, or by the use of a gauge. Allowable dimensions for worn components are as per manufacturers' specifications. If manufacturers' specifications are not available, allowable dimensions are given in Table 3.1.

**Table 3.1** Allowable dimensions in millimetres for worn components

Component	Standard dimension	Allowable wear limit*	Gauge Sizes
Coupling pin	48.7 OD	47.2 min	47.1
Drawbar eye bush	50.0 ID	51.5 max	51.6

\*When the wear of components is checked by direct measurement, it should be noted that an elliptical wear pattern is generated on the bore of the drawbar eye bush, and on the outside of the pin.

**Figure 3.4** Measurement of coupling pin and drawbar eye bush wear

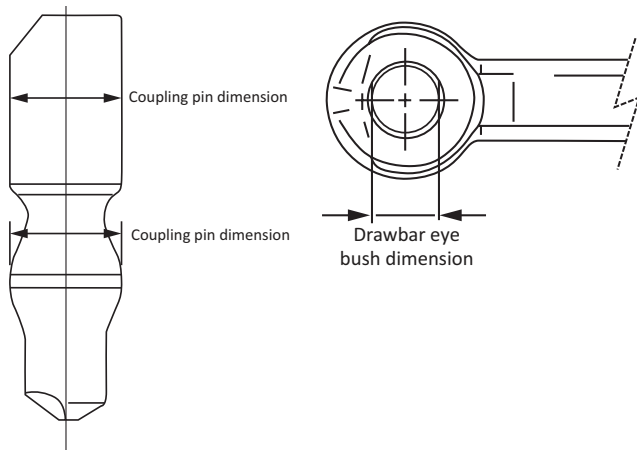

- i) Any transverse or circumferential welds on the drawbar eye block
- j) For bolt-in drawbar eyes, the castellated nut is loose or insecure or the split pin is missing or not intact.

### 3.3 Check towbar

#### Reasons for rejection

- a) The towbar is not securely mounted or is bent or cracked
- b) Any mounting bolts, fasteners or weld beads have advanced corrosion or cracks
- c) Where ADR 62 applies, the towbar and towing ring does not display: the manufacturer's name/trademark, the rating and the make and model of the vehicle/s for which it is designed
- d) Where any part of the towbar is removable (the bolts, studs, nuts etc.), fastening those parts do not have a locking device such as a U-clip, split pin or nylon lock nut
- e) Towbar assembly (except for vehicles designed for use in road trains) is not fitted with two safety chain attachments mounted one on either side of, and adjacent to, the tow coupling
- f) Safety chain attachments are not affixed to part of the tow assembly that is permanently attached to the vehicle.

**Note:** Always check the underside of drawbar and drawbar eye for excessive wear and cracks.

### 3.4 Check towing attachments

#### Reasons for rejection

- a) Any towing attachment (such as a tow-ball or pintle hook), any mounting bolts, fasteners or weld beads are loose, cracked, broken or extensively corroded
- b) Safety chain/s or cables (if required) are able to be connected or affixed in such a way that the safety chain/s or cables are liable to accidentally disconnect
- c) Safety chain or cable retaining brackets are cracked, deformed or insecure
- d) Safety chain or cable retaining brackets do not meet required standards
- e) The tow coupling capacity does not equal or exceed the aggregate trailer mass (ATM) of any trailer being towed (if applicable).

**Note:** For further information on safety chains, refer to *Additional Information – Safety Chains*.

## Additional Information – Safety Chains

Safety chains for:

- trailers in excess of 3.5 tonnes ATM
- trailers in excess of 2.5 tonnes GTM with fixed or rigid drawbars and automatic pin type couplings.

All fixed or rigid drawbar pig trailers (other than a converter dolly) and any other trailers without breakaway brakes, require safety chains to be fitted.

It is strongly recommended that all other trailers be fitted with safety chains, especially vehicles used in severe conditions, e.g. quarry vehicles which are jackknifed regularly for unloading.

Safety chains complement the safety features of the trailer's breakaway braking system, allowing the driver to maintain control of the truck and trailer combination following a coupling failure or disconnection.

Safety chains **MUST** be supplied and fitted to comply with the following requirements:

### Type of chain

Safety chains fitted to a trailer with an ATM over 3.5 tonnes, must be manufactured from alloy steel with a minimum breaking stress of 800MPa to conform with the mechanical properties of Grade T chain as specified in Australian Standard AS 2321 *Short-link chain for lifting purposes*.

### Required number and size of chains

**Two separate chains must be used.**

The minimum breaking strength or size of each chain used on the trailer must meet or exceed the values listed for the maximum gross trailer mass or aggregate trailer mass as indicated in Table 3.2.

Table 3.2 Safety chain size selection

#### Vehicles manufactured before 1 July 1998

Gross trailer mass (tonnes)	Chain size (millimetres)	Minimum chain breaking load (tonnes)
2.5–4.27	7.1	6.4
4.27–7.5	9.5	11.6
7.5–13.5	12.7	20.4
13.5–21.5	15.9	32.0
21.5–30.0	19.0	46.4
>30.0	22.0	63.2

#### Vehicles manufactured from 1 July 1998 to 31 December 2008

Aggregate trailer mass (tonnes)	Chain size (millimetres)	Minimum chain breaking load (tonnes)
Over 3.5 and up to 4.3	7.1	6.4
Over 4.3 and up to 7.5	9.5	11.6
Over 7.5 and up to 13.5	12.7	20.4
Over 13.5 and up to 21.5	15.9	32.0
Over 21.5 and up to 30.0	19.0	46.4
Over 30.0	22.0	63.2

#### Vehicles manufactured from 1 January 2009

Aggregate trailer mass (tonnes)	Chain size (millimetres)	Minimum chain breaking load (tonnes)
Over 3.5 and up to 5.0	6	5.1
Over 5.0 and up to 8.0	8	8.2
Over 8.0 and up to 12.5	10	12.8
Over 12.5 and up to 21.5	13	21.7
Over 21.5 and up to 32.5	16	32.8
Over 32.5	19	46.5



### Arrangement of chains

Safety chains must be arranged so that:

- the chains are attached to the trailer
- the chains are crossed to support the drawbar and prevent it from dropping to the ground in the event of coupling failure or disconnection
- the points of attachment to both the towing vehicle and the trailer must be as near as practicable to the coupling and arranged so as to maintain direction of the trailer in the event of coupling failure or disconnection.

**Ensure that the attachment fittings do not foul on the rear of the towing vehicle or trailer drawbar under any possible operating conditions.**

### Attachment of chains

Safety chains must be attached so that:

- the attachments to the towing vehicle and the trailer are capable of withstanding the specified breaking load of each chain
- the attachments to the towing vehicle and the trailer are separate from the coupling and its fasteners
- any safety chain attachment point affixing a safety chain to a drawbar must be located as near as practicable to the coupling. Where two points of attachment are required they must be mounted one on either side of the centreline of the drawbar
- the chain and coupling links are **NOT WELDED, DEFORMED OR ELECTROPLATED** subsequent to its manufacture.

Figure 3.5 “Berglok” coupling link

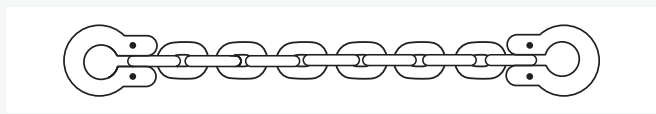

**Shackles are not permitted.**

**Ramshorn type hooks are not permitted.**

**Note:** Chain coupling attachment bracket and dimensional recommendations appear in Table 3.3.

### Chain attachment brackets

The dimensions and configurations of typical chain retention brackets are shown in the following table and diagram:

Table 3.3 Typical bracket dimensions

Minimum Chain (mm)	Minimum length of fillet weld	Bracket dimensions				
		Size length	(T1)	(T2)	(B)	(C)
9.5	6 x 200	16	16	4 x M12	19	*
12.7	6 x 360	20	20	4 x M16	25	*
15.9	8 x 420	25	20	4 x M20	32	*
19.0	10 x 480	25	25	4 x M20	38	*

\* Dimension ‘D’ to suit coupling link plus minimum clearance to prevent binding.

Figure 3.6 Typical attachment of chains

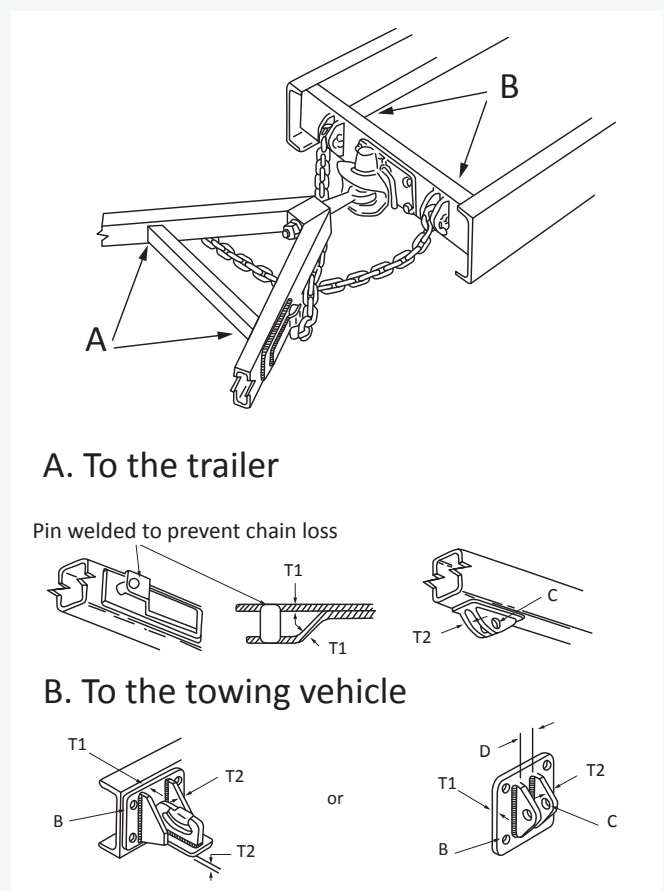

## Attachment pins

All pins used to connect safety chains to trailers and towing vehicles must be manufactured from steel bar with a minimum specification of 4140 or 4150 grade (Ultimate tensile strength – 1040MPa) unless otherwise approved.

Figure 3.7 Typical pin design

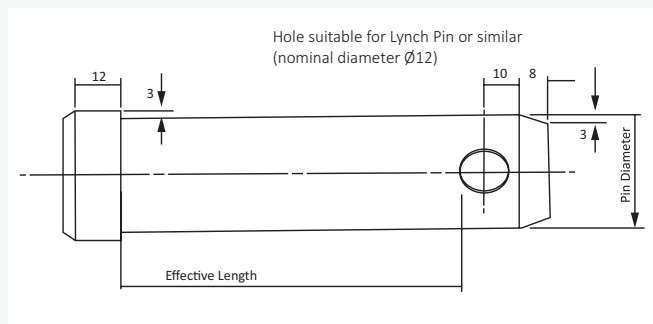

Material – Steel 4140 (Alternative 4150)  
– Ultimate tensile strength – 1040MPa

**Note:** Standard agricultural 3-point linkage pins are NOT suitable because they are manufactured from a lower grade of steel and will not meet the load requirements. It is acceptable to use a metric class 10.9 bolt of the correct diameter providing that the threaded portion of the bolt is clear of the brackets.



## Section 4

# Steering and Suspension

### Objective:

To ensure that the steering and suspension is in good working order and allows the driver effective control of the vehicle.

Australian Design Rules relevant to this section:

**ADR 42** General safety requirements

**ADR 43** Vehicle configuration and dimensions

### 4.1 Check steering components inside cabin

#### Reasons for rejection

- a) Steering wheel is not located in the centre or to the right-hand side of the vehicle unless the vehicle is built and used for a purpose other than the transportation of goods or people
- b) The steering wheel is loose on the shaft
- c) The steering column is insecure
- d) The steering wheel structure is fractured or the hub, rim, moulding or spokes are loose
- e) Any steering component is missing, loose, cracked, heated, bent, welded, damaged or inoperative.

### 4.2 Check steering free play

#### Reason for rejection

- a) With the road wheels in the straight ahead position and the engine running (if the vehicle has power steering), rotational free play measured at a point on the steering wheel exceeds the limits in Table 4.1, without road wheel movement.

Table 4.1 Steering wheel diameter and free play

Steering wheel diameter (mm)	Movement (mm)
up to 450	75
over 450	100



### 4.3 Check steering components under the bonnet and under the vehicle

#### Reasons for rejection

- Any steering component is missing, cracked or broken
- Any steering component fouls another component under any combination of steering and/or suspension travel
- Any threaded, splined or tapered joint is loose
- Any free-play due to wear in a ball-joint exceeds manufacturer's specifications. Where these are not known or are no longer appropriate, the free-play exceeds 3mm

**Note:** Some ball type steering joints are spring loaded or are designed to have a certain amount of play.

- Any steering component can be seen to have been repaired or modified by heating or welding

**Note:** Except where an original component has been fitted by the manufacturer or repairs have been conducted to the manufacturer's specifications.

- Any nut, bolt or locking device is missing or insecure
- Where steering forces are wholly supplied by energy sources other than a driver's muscular effort, visible indicators for steering failure or defect are not fitted
- The power steering pump has loose mounting bolts cracked or broken mounting brackets, braces or adaptors, or is inoperative
- Power steering pump pulleys are cracked, broken or loose
- Power steering pump belts are loose, cracked through to reinforcing plies, extensively frayed or missing drive sections
- Evidence of oil or fluid leaking from any power steering components

**Note:** Dampness or staining around seals is acceptable.

- With the wheels off the ground, the steered road wheels do not turn freely to the left and right through their normal range of travel
- Steering shaft is not securely connected to the steering box or rack, or is incorrectly aligned or adjusted
- Steering box, rack and pinion assembly, mounting brackets, bolts or couplings are cracked or not securely fixed to the vehicle
- Play at the end of the idler arm exceeds 8mm

Figure 4.1 Idler arm free play

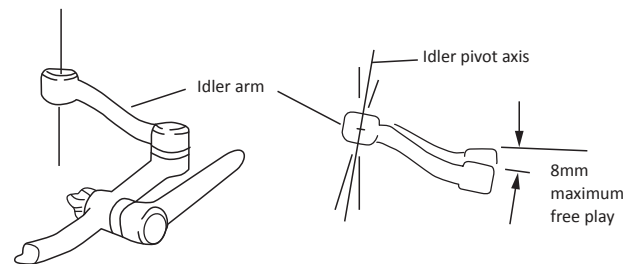

- Free play at the steered road wheel rim in a horizontal or vertical plane (excluding any necessary wheel bearing play) exceeds manufacturer's specifications. Where these specifications are not known or are no longer appropriate, free play exceeds the limits in Table 4.2

Table 4.2 Rim diameter and free play

Rim diameter (mm)	Free play (mm)
up to 405	7.0
over 405 to 455	10.0
over 455	13.0

Figure 4.2 Typical 'I' beam axle

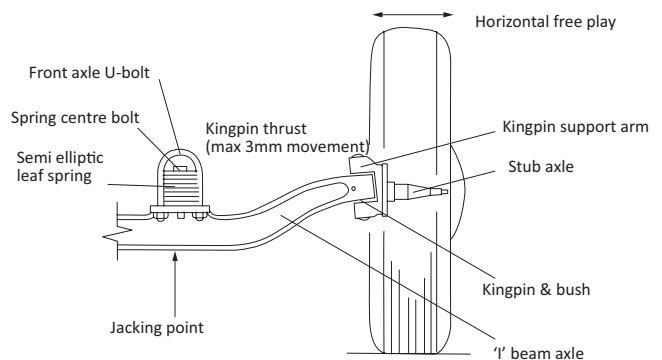

- Any noticeable movement due to wear in any component exceeds manufacturer's specification, or 3mm where this is unknown
- Tyres come into contact with any part of the vehicle through normal range of travel.

Figure 4.3 Steering linkage typical of most heavy vehicles

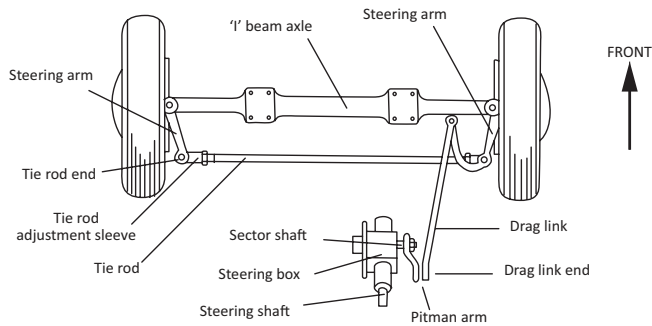

#### 4.4 Check suspension components

##### Reasons for rejection

- a) U-bolts or other spring to axle or spring pack clamp bolts, centre bolts, spring eyes or hangers, torque, radius or tracking component assemblies, control arms, sway bars, bushes or any parts used to attach them to the vehicle frame or axle are cracked, loose, broken, missing or worn beyond manufacturers' limits

**Note:** Superficial crazing is acceptable on rubber bushes. This is often present on rubber suspension components even when new.

Some vehicle suspensions are designed to move within their rubber bushing considerably.

- b) Springs are cracked, broken, missing or damaged
- c) Springs (including air bags) are sagged or air bag/ components leak
- d) Leaves in a leaf spring are displaced sideways more than 10% of their width or so that they contact wheels, brakes or the frame
- e) Shock absorbers, if originally fitted, are missing, loose, inoperative or leaking

**Note:** Shock absorber misting is not considered leaking.

For further information refer to Additional Information – Shock Absorber Leakage and Misting.

- f) Any suspension component is not correctly aligned or is damaged, cracked, loose or broken
- g) Any nut, bolt or locking mechanism is insecure or missing
- h) Suspension components are missing, or repaired or modified by heating or welding unless it's a manufacturer's approved repair technique.

**Note:** Repairs using either heating or welding may adversely affect the strength of suspension components. Any such repairs should only be affected in consultation with the vehicle or component manufacturer.

## Additional Information – Shock Absorber Leakage and Misting

### Misting

By design, the piston rod carries a film of oil through the rod seal to lubricate the seal lips, thereby reducing friction and wear at the seal contact area, and prolonging seal life. Misting occurs when the hot piston rod is drawn out of the shock body and the microscopic film of hot oil on the rod turns to vapour. This vapour, or mist, condenses when it reaches the cooler outside air, and forms a film on the outside of the shock body. The film will attract road dust and debris, and will often coat the entire body of the shock. Misting is normal and is not a reason for rejection.

Figure 4.4 Examples of misting shock absorbers



### Leaking

Rod seals may leak as a result of extreme wear, contamination, or defect. A leaking shock will show clear signs of oil leaking in streams from the upper seal down the shock body and may drip from the shock. Leaking is not acceptable and is a reason for rejection.

Figure 4.5 Examples of leaking shock absorbers



**Note:** Some minor streaking of oil may appear on a new shock body during initial stroking. This is the result of the seal 'setting' and purging any oil (from assembly) from the seal. This is not to be mistaken as a failure, as it is temporary and totals only a few millilitres of oil.





## Section 5

# Wheels, Tyres and Hubs

### Objective:

To ensure that road wheels and tyres are of a suitable type and condition and that they provide the necessary load carrying capacity, speed rating and control of the vehicle.

Australian Design Rules relevant to this section:

**ADR 42** General safety requirements

### 5.1 Check wheels and rims

#### Reasons for rejection

- a) Any wheel or rim:
  - is loose
  - is cracked
  - is buckled
  - has pieces of casting missing
  - has elongated stud holes
  - has weld repairs not in accordance with relevant industry practice.
- b) Any wheel contacts unrelated vehicle components at any point through its full range of travel
- c) Spindle nuts and washers are missing, cracked, stripped or broken
- d) Spiders have cracks across a spoke, hub or area
- e) Wheels are not compatible with hubs
- f) Required valve protection lugs are missing

- g) Wheels fail to rotate freely
- h) Hubs seals are leaking
- i) Excessive end-play in hubs.

### 5.2 Check wheel/rim fasteners

#### Reasons for rejection

- a) Wheel nuts and bolts do not have a thread engagement length at least equal to the thread diameter (except where specified by the vehicle manufacturer), or the fitting of the wheel nut does not match the taper of the wheel stud hole
- b) Any hub has missing, cracked, stripped or broken wheel mounting nuts, studs or bolts
- c) Spacer plates are used between hub and wheels, except where fitted by the vehicle manufacturer
- d) Fasteners are not of the correct type for the wheel being used or allow a rim to slip on its spider

- e) Any item that is fitted to the tyre, rim or wheel (other than tyre pressure monitoring or inflation) which is not technically essential to the vehicle, protrudes from any part of the vehicle so that it is likely to increase the risk of bodily injury to any person
- f) Any item that is fitted to the tyre/rim/wheel (other than tyre pressure monitoring or inflation) which is technically essential to the vehicle, is not designed, constructed and affixed to the vehicle in a way that does not minimise the risk of bodily injury to any person.

### 5.3 Check retaining rings

#### Reason for rejection

- a) Lock or side rings are incorrectly seated, sprung, mismatched, bent, broken or cracked.

### 5.4 Check tyres

#### Reasons for rejection

- a) A tyre does not have at least 1.5mm tread depth in the principal groove, in a continuous band which runs around the whole circumference of the tyre and extends across at least 75% of the width of the tyre

**Note:** For further information on how to measure tyre tread depth see additional information – Measuring Tyre Tread.

**Note:** Tread wear indicators are built into most tyres to indicate when tread depth reaches about 1.5mm. The depth of the tyre tread above these indicators is not included in the assessment of tread depth around the circumference of a tyre.

*In effect, these requirements allow a tyre to be worn to less than 1.5mm tread depth on its edges, provided that at least 75% of the remaining width of the tyre has a minimum tread depth of 1.5mm around the whole circumference.*

- b) The tyres do not match the manufacturer's tyre placard (if fitted) or modification approval
- c) A tyre (including sidewalls) has deep cuts, chunking, bumps, bulges, exposed cords or other signs of carcass failure
- d) A tyre has been re-grooved (except where indicated on the side wall that the tyres are suitable for re-grooving)
- e) When in the straight ahead position, the sidewall of any tyre projects beyond the extreme width of the mudguards

**Note:** This excludes elevations due to labelling, decoration or protective bands.

- f) The vehicle has been fitted with a non-OEM front wheel (i.e. rim and tyre) that has not been approved as a modification

**Note:** For further information on modifications refer to Appendix B – Vehicle Modifications.

- g) Any tyre is not of a type constructed for unrestricted road use
- h) Any retreaded or remoulded tyre is not marked with the words "RETREAD" or "REMOULD", and where speed limited the words "MAX. SPEED XX KM/H" or "SPEED LIMITED TO XX KM/H" (XX means the max speed i.e. 125km/h)

**Note:** For more information on retreaded tyres, refer to Additional Information – Retreaded Tyres.

- i) The speed rating of all tyres is not of at least 100km/h or the vehicle's top speed, whichever is the lesser, unless a lower rating has been specified by the manufacturer
- j) Any tyre fitted to an axle is not of sufficient size and capacity to carry the part of the vehicle's gross mass transmitted to the ground through that axle
- k) Dual tyres contact each other
- l) Any tyre on a vehicle contacts the body, chassis, frame, braking, steering or suspension components at any point through its full range of travel
- m) A tyre has cleats or other gripping devices that could damage road surfaces
- n) Tyres are not compatible with the rim to which they are fitted.

## Additional Information – Retreaded Tyres

The use of retreaded tyres must be in accordance with Australian Standard AS 1973 *Pneumatic tyres – Passenger car, light truck, and truck/bus – Retreading and repair processes*. The details listed below advise of the requirements listed in AS 1973 to ensure compliance.

### Marking of retreaded tyres

#### Marking on one side:

Each retreaded tyre must bear on at least one side wall or shoulder the following marking:

- a) The nominal size of the tyre
- b) The word 'RADIAL' or 'R' in the size designation, for a radial ply tyre
- c) The word 'TUBELESS', if applicable
- d) The maximum load rating, ply rating, or service description of the tyre.

**Note:** *In the case of a remould, the service description is to be clearly identified as the original service description applicable to the tyre when new.*

#### Marking on both sides:

Each retreaded tyre must bear on both side walls or shoulders the following marking:

- a) The word 'RETREAD' or 'REMOULD', if applicable  
**Note:** *The maximum speed rating must be placed adjacent to 'Retread' or 'Remould', as applicable.*
- b) For light truck tyres, the maximum speed rating, expressed as follows:
  - i) For tyres having an original speed category when new of 'L' (120km/h) or higher, 'MAX SPEED 120km/h', or 'MAXIMUM SPEED 120km/h', or 'SPEED LIMITED 120km/h'
  - ii) For tyres having an original speed category when new of less than 'L' (120km/h), the original speed category.  
**Note:** *The maximum speed rating must be placed adjacent to 'Retread' or 'Remould', as applicable.*
- c) For truck/bus tyres:
  - i) The speed equivalent to the original speed category.  
**Note:** *Retention of the original speed category on both side walls is sufficient to satisfy this requirement.*
  - ii) If structural belts have been replaced, the word 'REBELTED', and
  - iii) The word 'REGROOVABLE' if the retread is specifically designed for regrooving. Only tyres marked regroovable are permitted to be regrooved.

**Note:** *After major repairs have been carried out in the crown area, regrooving may be performed to reinstate tread grooves.*

- d) For speed limited truck or bus tyres:
  - i) The original speed symbol must be removed from the tyre
  - ii) Each speed limited tyre must bear on both side walls or shoulder of the retreaded tyre the following marking, 'max. speed 80km/h' or 'speed limited to 80km/h'.

#### Method and position of marking:

All new marking (except for date code) on a retreaded tyre must be in letters not less than 4mm high, be permanently and legibly marked in the shoulder or upper side wall of the tyre, and be durable for the life of the retread. Date coding must be a digit week/year code. Branding with a hot iron is not permitted on light truck tyres.

#### Removal of marking:

The following information must be removed from the tyre during retreading:

- a) The word 'TUBELESS' if a tyre originally designated as tubeless has been converted to tube type
- b) The word 'REGROOVABLE' if the retread is not designed for regrooving
- c) Any previous retreader's name or registered trademark
- d) Any marks of approval.

Removal or mutilation of any original tyre speed category symbol is not required on light truck tyres.

Any original speed category for truck/bus tyres must not be removed.

#### Marking on repaired tyres:

Repaired tyres must be marked as follows:

- a) All major repairs must be marked, in a legible and permanent manner, with the identification of the repairer and the date on which the repair was carried out

**Note:** *Marking is not required for unreinforced repairs.*

- b) The word 'TUBELESS' must be removed if the tyre, originally designed as tubeless, has been converted to tube type.

Branding with a hot iron is not permitted on light truck tyres.



## Definitions

- Retreading:** is the process of reconditioning a worn tyre by topcapping, fullcapping, remoulding, or the application of a pre-cured tread.
- Remoulding:** is a retreading process in which new rubber is applied to the casing extending from bead area to bead area.
- Topcapping:** is a retreading process in which tread rubber is applied only to the tread area of the buffed casing.
- Fullcapping:** is a retreading process in which new tread rubber is applied to the area of the casing normally in contact with the road and extending over the shoulder area.
- Shoulder:** is the transitional area of a tyre between the side wall and the crown.
- Precured retreading:** is the process by which a previously cured and patterned tread is cured to the casing.

## Additional Information – Measuring Tyre Tread

Tyres are constructed with both principal and secondary grooves. Most tyres are fitted with wear indicators that indicate when tread depth reaches about 1.5mm, these indicators are located in the principal grooves of the tyre.

It is important to ensure that tread depth is measured in the principal grooves of the tyre and not the secondary grooves which are the shallow grooves in the tyre tread that may disappear during the life of the tyre through normal wear.

## Definitions

- Principal grooves:** in relation to a tyre, means wide grooves, other than secondary grooves —  
(a) usually positioned in the central zone of the tyre tread but that may run across the tyre tread; and  
(b) in which tread wear indicators are usually located.
- Secondary grooves:** in relation to a tyre, means shallow grooves in the tyre tread that may disappear during the life of the tyre through wear.
- Tread wear indicators:** in relation to a tyre, means projections within a groove of the tyre that indicate the degree of wear on the tyre's tread.



## Section 6

# Structure and Body Condition

### Objective:

To ensure the vehicle body is free of protrusions, structurally sound and free from any defects or additional fittings that are likely to increase the risk of bodily injury to any occupant and other road users.

### Australian Design Rules relevant to this section:

- ADR 18** Instrumentation
- ADR 42** General safety requirements
- ADR 43** Vehicle configuration and dimensions
- ADR 44** Specific purpose vehicle requirements
- ADR 58** Requirements for omnibuses designed for hire and reward
- ADR 59** Omnibus roll-over strength
- ADR 63** Trailers designed for use in road trains
- ADR 64** Heavy goods vehicles designed for use in road trains and B-doubles
- ADR 84** Front underrun impact protection

### 6.1 Check exterior body panels and fittings

#### Reasons for rejection

- a) Any item which is not technically essential to the vehicle, protrudes from any part of the vehicle so that it is likely to increase the risk of bodily injury to any person
- b) Any item which is technically essential to the vehicle, is not designed, constructed and affixed to the vehicle in a way that does not minimise the risk of bodily injury to any person
- c) Mudguards are not properly fitted to provide protection over the full width of the wheels and tyres and any mudguard does not extend inboard over the full width of the tyre/s (except where part of the body of the vehicle acts as a mudguard)
- d) The bottom edge of mudguard and/or mudflap at the rear of any vehicle is higher off the ground than 37% of the horizontal distance between the centre of the axle and the mudguard

**Note:** The height of the mudguard and/or mudflap from the ground need not be less than 230mm, or for a vehicle to be used off-road 300mm.

- e) Any motor vehicle which is 2.2 metres or more in width and fitted with a body which is less than 300mm in height at the rear, measured from the lowest point of the body above the ground to the highest point, does not have the rear face of any rear mudguards silver or white in colour

**Note:** Reasons for rejection (e) does not apply when a vehicle is correctly fitted with rear marking plates.

- f) Any vehicle over 12 tonnes GVM manufactured on or after 1 January 2012 is not fitted with front underrun protection (FUP).

**Note:** FUP is not mandatory on heavy vehicles under 12 tonnes GVM or off-road vehicles.

A vehicle is considered to be off-road in relation to the fitment of FUP, either if the wheels are designed to be driven simultaneously, including vehicles where the drive to one axle can be disengaged, or if the following requirements are satisfied:

- at least half the wheels are driven
- there is at least one differential locking mechanism or at least one mechanism having a similar effect
- the vehicle can climb a 25% gradient calculated for a solo vehicle
- at least four of the following six requirements are satisfied:
  - the approach angle must be at least 25°
  - the departure angle must be at least 25°
  - the ramp angle must be at least 25°
  - the ground clearance under the front axle must be at least 250mm
  - the ground clearance between the axles must be at least 300mm
  - the ground clearance under the rear axle must be at least 250mm.

For further information on mudguard requirements, refer to Additional Information – Mudguard and Mudflap Requirements.

## 6.2 Check rear marking plates

### Reasons for rejection

- a) any vehicle with a GVM over 12 tonnes not fitted with retroreflective rear marking plates, except:
- a bus fitted with hand grips or similar equipment for standing passengers to hold
  - a vehicle fitted with conspicuity markings
- b) Rear marking plates are not fitted in locations specified by VSB12

- c) Rear marking plates are faded, damaged or incorrectly fitted.

**Note:** For more detailed information on rear marking plates refer to Vehicle Standards Bulletin 12 (VSB12) National Code of Practice: Rear Marking Plates. A copy of VSB12 may be obtained from the NHVR website at [www.nhvr.gov.au/vehiclestandards](http://www.nhvr.gov.au/vehiclestandards)

## 6.3 Check cabin and body condition

### Reasons for rejection

- a) Any structural member of a body, cabin or chassis such as a cross-member, door sill, pillar, seat or seatbelt anchorage, roof rail and floor panel is cracked, broken or corroded to an extent that weakens the strength of the vehicle or any safety system, or allows the entry of engine fumes into an occupant space
- b) Any cabin, body, sleeper compartment, load carrying area or compartment is loose on the chassis or has missing fasteners
- c) Any load carrying area or compartment is damaged, deteriorated, corroded or distorted so that any part of the load is not retained
- d) Any door, gate, hatch, bonnet or compartment latch, latch control, or hinge is damaged, excessively worn, insecure or inoperative in any latching position
- e) Any body repairs on the vehicle have not been carried out in accordance with recognised industry repair methods and standards
- f) Any item which is not technically essential to the vehicle, protrudes from any part of the vehicle so that it is likely to increase the risk of bodily injury to any person
- g) Any component that adversely affects the safety of the vehicle, and, in particular, obscures the drivers view.

**Note:** For further information on rust and body condition, refer to Additional Information – Rust and Corrosion.

## 6.4 Check number plates

### Reasons for rejection

- a) Any number plate is obscured, for example, by a towing attachment, goose neck or tow ball
- b) Any number plate cover is tinted, reflective, rounded or bubble-like
- c) Any number plate is not issued or approved by the state or territory road transport authority, is damaged or faded to the extent that the registration number is not legible from a distance of 20 metres
- d) The number plates are not substantially parallel to the vehicles axles
- e) Any number plate is fitted to a hinged plate that enables the plate to hinge whilst the vehicle is in motion



- f) Any number plate is mounted more than 1300mm from the ground

**Note:** State or territory road transport authorities may allow a number plate to be attached more than 1300mm from the ground if the design of the vehicle does not allow it to be installed at the required height. For more information about this requirement, contact the state or territory road transport authority.

- g) Characters on any number plate are not clearly visible from a distance of 20 metres at any point within an arc of 45 degrees from the surface of the number plate above or to either side of the vehicle
- h) A rear number plate is positioned so that it is not illuminated by at least one number plate light.

## 6.5 Check electrical equipment

### Reasons for rejection

- a) A warning device (horn) that is capable of providing sufficient audible warning to other road users is not fitted or is not operational or the tone is not of a constant amplitude or frequency
- b) A warning device (horn) is not clearly audible and the actuating mechanism is not located within the reach of the driver in the normal seated position
- c) Electrical wiring or connectors are corroded, damaged, not insulated or are not securely fastened at least every 600mm or are located in such a way that would cause danger to the operation of the vehicle
- d) Electrical wiring is located where it can:
  - become exposed to excessive heat
  - hinders driver or passenger movement
  - come into contact with moving parts
  - cause a fire hazard.
- e) Batteries are not securely mounted, leak or are situated in an occupant space without adequate protection from spillage and fumes.

## 6.6 Check chassis

### Reasons for rejection

- a) Any part of the chassis or sub-frame is:
  - cracked
  - distorted
  - sagging
  - loose, broken, or
  - affected by extensive or advanced rust.

**Note:** Refer to Additional Information – Rust and Corrosion for a detailed explanation of checking for rust.

- b) Any fastenings between frame members, including welds, are missing, loose, distorted or cracked
- c) Any chassis or sub-frame repairs on the vehicle have not been carried out in accordance with recognised industry repair methods and standard
- d) Frame members in load areas are missing or damaged to an extent that the load area is not properly supported or the members are likely to fall out or contact moving parts
- e) Any vehicle wheelbase that has been lengthened or shortened without certification to Section C and H of VSB6
- f) Body mounting is not done to manufacturers' recommendations, VSB6 or:
  - Body mounting brackets bolted to the flange of the chassis rail
  - U-bolts used, and vehicle does not have a box type frame, or metal spacers are not inserted between the top and bottom flanges of the chassis rail to prevent distortion of the flanges below the U-bolts
  - Wooden runners are used, and they are not protected from damage by the U-bolts by steel capping or shaped spacers under the bolts
  - U-bolts are used, and less than four outrigger brackets or fishplates used, with one on each side of the vehicle at the front and rear.

**Note:** For further information on modifications, refer to Appendix B – Vehicle Modifications.

Figure 6.1 Example of critical structural components

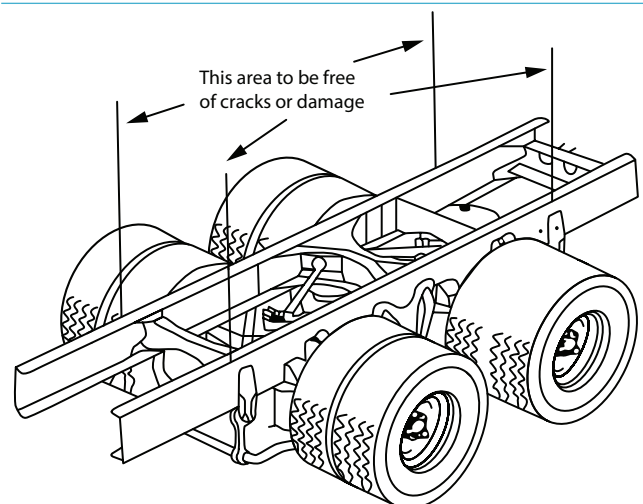

## Additional Information – Mudguard and Mudflap Requirements

Effective mudguards must be fitted for all wheels on all vehicles. However, this does not apply to a vehicle if the construction or use of the vehicle makes the fitting of mudguards unnecessary or impractical. Examples are:

- pole type trailers used to carry timber
- most road making plant
- some agricultural equipment.

Mudguards and mudflaps must be capable of deflecting downwards any mud, water, stones or any other substance thrown upward by the rotation of the wheels. As outlined in Figure 6.2, mudguards must be fitted to the vehicle in such a manner that provides continuous protection between a point in area A and a point in area B and must be provided for the overall tyre width of all tyres.

Notwithstanding the requirements specified above, the mudguard, including a mudflap (if fitted), does not need to come any lower than 230mm from the ground, or for an off-road vehicle, 300mm.

Figure 6.2 Mudguard and mudflap protection area

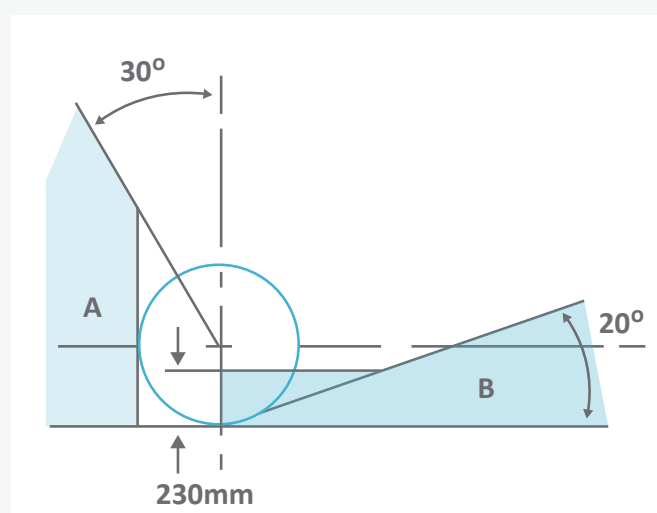

## Additional Information – Rust and Corrosion

### Classification of rust

The extent of corrosion in a vehicle can range from light surface rust to the total breakdown of parent metal.

Depending on the individual vehicle's design, there are many different ways in which corrosion can begin and the degree to which a material or structure is attacked can vary widely. In general, though, the formation of rust and resultant loss of metal occurs in areas which retain moisture because of a build-up of road dirt and mud, for example.

In order to simplify identification and classification when carrying out a vehicle inspection, this publication classifies the extent of corrosion in three different stages.

#### Stage 1 - Surface rust

Light, powdery corrosion on the surface of a section of metal is termed surface rust and is sometimes the first indication of corrosion that can be observed; it should warn the owner of the vehicle to take steps for preventing the rust from spreading. Surface rust can occur on or behind any body panel of a vehicle particularly if the protective coating is scratched or damaged.

#### Stage 2 - Advanced rust

Surface rust, if left unattended, will develop into an advanced form of corrosion which can usually be seen as an eruption of oxidised metal, either on bare metal or under paint. This eruption occurs because the rust reaction involves an increase in volume so that pitting or bubbling of paint is the usual indication of penetration.

#### Stage 3 - Extensive rust

The final stage of the corrosion process is the formation of heavy encrustation of oxidised metal which completely replaces the parent metal. This results in a hole or series of holes in the body panel or structural member of the vehicle when the rust is removed. This category of rust can usually only be rectified by replacement of the affected body panels and parts.

### Classification of vehicle structures

Vehicle structural components can be categorised according to their importance to safety. For instance, sub-frames and other basic structural sections have to be absolutely free of rust because their failure could make a vehicle difficult to control and might cause it to crash. As already mentioned, such failures will also probably reduce the chances of survival in a crash.

### Primary structure

This category includes any structure or component which, if it collapsed, would make the vehicle uncontrollable or would considerably reduce occupant safety in a crash. Examples of components in this category are illustrated below.

#### Typical primary structure components

1. Main structural members such as sub-frames and chassis rails
2. Suspension mountings and parts
3. Steering component mounting points
4. Door sills and pillars
5. Door hinges and latch mounting points
6. Seat anchorage points
7. Seatbelt anchorage points
8. All floor panels
9. Bulkheads.

Figure 6.3 Primary structure components

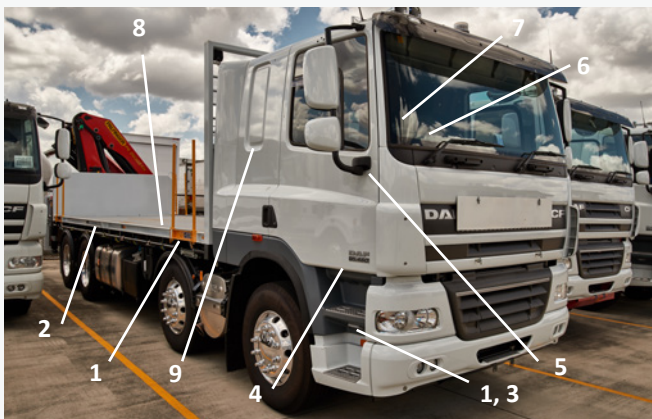

### Secondary structure

The second category includes any structure or component which, if it collapsed, would not immediately affect a vehicle’s controllability or the protection provided by its built-in safety systems. Normally, surface rust or advanced rust would not be a cause for rejection in these components but extensive rust is usually either hazardous to persons in or near the vehicle because of its sharp edges or because exhaust fumes can get into the vehicle. In such cases, extensive rust must therefore be rejected. The illustration below shows examples covered by this category.

### Typical secondary structure components

1. Mudguards or fenders
2. Roof
3. Bonnet and doors (areas within 100mm of mounting and locking points are primary structures and must be free of advanced or extensive rust)
4. Exhaust system.

Figure 6.4 Secondary structure components



### Reasons for rejection

The following table summarises the acceptability of rusted components in terms of the categories of rust and structures described so far. Remember that it is a general guide only and that in some cases it might be necessary to depart from the table.

Table 6.1 Acceptability of rusted components

Type of corrosion	Category of structure	
Measure	Primary	Secondary
Surface rust	Acceptable	Acceptable
Advanced rust	Not acceptable	Acceptable (See Note A)
Extensive rust	Not acceptable	Not acceptable (See Note B)

**Note A:** Areas within 100mm of hinges and locks (e.g. bonnet and doors), are considered primary structures and must be free of advanced and extensive rust.

**Note B:** Extensive rust is not acceptable in secondary components if it has resulted in hazardous conditions to persons in or near the vehicle e.g. sharp edges, loose panels or, in the case of exhaust system, gas leaks.



## Inspection method

Visual inspection is usually adequate since advanced corrosion is almost always associated with an eruption of oxidised metal and pitting or bubbling of paint.

However, this method may not be adequate in all cases. In under body areas prone to rusts, such as steering and suspension mounting points and major structural components which include chassis, floor, structural sills and sub-frames, presence of rust should be checked by probing with a rod. This method should also be used to check for presence of rust in other areas where cosmetic damage is not a problem, such as inside wheel arches.

In using this technique, great care must be taken to ensure that sound panels or paint work are not scratched or damaged in any way. It should be remembered that the purpose of such checks is to find out whether rust is present, not to determine its extent.

When checking for advanced rust, you should pay particular attention to seam welds and spot weld. These frequently corrode through from the interior and can result in the eventual detachment of panels. Any panel which is made insecure by such corrosion must be repaired even if it is an area of the component where rust holes are not an immediate danger.

## Repairs

Surface rust on a component or structure is not immediately dangerous and is not a reason for rejection. However, if it is observed, the owner should be advised to have it rectified before it becomes serious. Rectification is simply a matter of completely removing the deposit and applying a rust-proofing coating or oil as is appropriate (body panels should be repainted using a good quality re-finishing system).

It should be noted that repairs made to primary structure components solely by using body filling compounds are not acceptable. However, plastic filler or fibreglass can be used to smooth a non-structural component. A vehicle must not pass an inspection if it is found that a repair to a primary component is carried out by methods which do not restore the original strength of the component or part. A good way to check for continuity of structure if a fibreglass repair is suspected, is to run a magnet over the surface.

Extensive rust in structural members can only be repaired by replacing the affected member or by completely removing all rusted material and reinforcing it so that the original strength of the affected structural member is re-established.

Where a primary structure is found to be in need of repair and the repaired component would normally be coated with a bituminous coating or covered by another vehicle component such as a seat or a floor mat, it is quite in order to ask the owner to resubmit the repaired vehicle before the repairs are obscured so that the adequacy of the repairs can be assessed. A note to this effect should be made on the inspection report if this is required.



## Section 7

# Seats and Seatbelts

### Objective:

To ensure that all seating and restraints fitted to the vehicle provide a safe and secure position for passengers to travel in the vehicle and the driver to control the vehicle.

### Australian Design Rules relevant to this section:

**ADR 3** Seat and seat anchorages

**ADR 4** Seatbelts

**ADR 5** Anchorages for seatbelts

**ADR 34** Child restraint anchorages and child restraint anchor fittings

**ADR 58** Requirements for omnibuses designed for hire and reward

**ADR 66** Seat strength, seat anchorage strength and padding in omnibuses

**ADR 68** Occupant protection in buses

### 7.1 Check seats

#### Reasons for rejection

- a) Seat frames or attaching points are loose, cracked, broken or have fasteners missing
- b) Seat cushions and backrests are not fitted
- c) A seat slide or other seat control used for adjustment of a seating position is not operational and does not hold any selected position allowed for in the mechanism's design
- d) Any seat has an exposed sharp edge or other parts that protrude due to damage
- e) Any reduction or increase in seating capacity is not approved

## 7.2 Check seatbelts

### Reasons for rejection

- a) Seatbelt assemblies are not securely attached to the respective anchorage point or show signs of distortion, cracks, fractures, or other damage likely to cause failure
- b) Any retractor, locking mechanism, buckle, tongue or adjustment device is inoperative
- c) Seatbelt webbing that is:
  - damaged
  - frayed
  - stretched
  - tied in a knot
  - twisted
  - split
  - torn
  - altered or modified
  - severely deteriorated
  - burnt
  - not correctly and firmly secured to each end fitting
  - not the appropriate seatbelt for the type of seat mechanism fitted.
- d) Seatbelts are not fitted in accordance with Table 7.1.

**Note:** Discolouration alone is not reason for rejection, however if there is a texture change as well it should be rejected.

Table 7.1 Seatbelt requirements

Minimum seatbelt requirements for goods vehicles	
Medium goods vehicles with a GVM exceeding 4.5 tonnes and up to 12 tonnes GVM (ADR Category NB2)	
1 July 1977 → 30 June 1992	Lap belts in front outboard seating positions
1 July 1992 →	Lap/sash belts with safety locking retractors in all front outboard seating positions and lap belts in all other positions.
Heavy goods vehicles with a GVM exceeding 12 tonnes (ADR Category NC)	
1 July 1977 → 30 June 1992	Lap belts in front outboard seating positions
1 July 1992 → 30 June 2008	Lap belts with safety locking retractors in front outboard seating positions and lap belts in all other positions
1 July 2008 →	Lap/sash belts with safety locking retractors in all front outboard seating positions and lap belts in all other positions.

**Note:** For further information on seatbelts, refer to Additional Information – ADR Occupant Restraint Requirements.

## 7.3 Child restraint anchorages

### Reasons for rejection

- a) The vehicle structure within 100mm of a child restraint anchorage (CRA) point is cracked or has advanced rust
- b) A 5/16" - 18 TPI UNC bolt and suitable spacer installed is not fitted to each CRA point
- c) A CRA fitting is not readily accessible or cannot be attached or unclipped by hand
- d) A CRA fitting is missing, loose or damaged
- e) For an MD4 category vehicle built from 1 July 1995 or ME category vehicle built from 1 July 1994, at least six rear seating positions are not equipped with a CRA point.

**Note:** For further information about ADR vehicle categories, refer to Additional Information – ADR Occupant Restraint Requirements.

## Additional Information – ADR Occupant Restraint Requirements

This additional information provides a guide to the minimum requirements for seatbelts and their anchorages.

The precise requirements are made under the applicable Australian Design Rules (ADRs).

The requirements are determined by the vehicle type and its date of manufacture and outlined in the following tables.

Vehicles within each category, manufactured on or after the date shown must be fitted with the correct type of seatbelt.

### Application tables

Each vehicle category manufactured on or after the date shown in the following tables must be fitted with seatbelts as indicated.

Table 7.2 MD4 – Omnibus (GVM exceeding 4.5 tonnes but not 5 tonnes)

		ADR 32A	ADR 5/00	ADR 5/01	ADR 5/02	ADR 5/03	ADR 5/04 <sup>(5)</sup>	ADR 5/05 <sup>(5)</sup>
Vehicle built between		1 July 1987 → 30 June 1988	1 July 1988 → 30 June 1990	1 July 1990 → 30 June 1992	1 July 1992 → 30 June 1996	1 July 1996 → 31 December 1999	1 January 2000 → 30 June 2008	1 July 2008 →
Front row	Driver	L	L	L	R	R	R	R
	Outboard passenger	L	-	-	R <sup>(2)</sup>	R <sup>(2)</sup>	R <sup>(2)</sup>	R
	Centre	-	-	-	L <sup>(1)</sup>	L <sup>(1)</sup>	L <sup>(1)</sup>	R <sup>(3)</sup>
Second row	Outboard	-	-	-	L <sup>(1)</sup>	L <sup>(1)</sup>	L <sup>(1)</sup>	R <sup>(3)</sup>
	Centre	-	-	-	L <sup>(1)</sup>	L <sup>(1)</sup>	L <sup>(1)</sup>	R <sup>(3)</sup>
Other rows	Outboard	-	-	-	L <sup>(1)</sup>	L <sup>(1)</sup>	L <sup>(1)</sup>	R <sup>(3)</sup>
	Centre	-	-	-	L <sup>(1)</sup>	L <sup>(1)</sup>	L <sup>(1)</sup>	R <sup>(3)</sup>

Table 7.3 ME – Heavy Omnibus (GVM exceeds 5 tonnes)

		ADR 32A	ADR 5/00	ADR 5/01	ADR 5/02	ADR 5/03	ADR 5/04 <sup>(5)</sup>	ADR 5/05 <sup>(5)</sup>
Vehicle built between		1 July 1987 → 30 June 1988	1 July 1988 → 30 June 1990	1 July 1990 → 30 June 1992	1 July 1992 → 30 June 1996	1 July 1996 → 31 December 1999	1 January 2000 → 30 June 2008	1 July 2008 →
Front row	Driver	L	L	L	L-R	L-R	L-R	R
	Outboard passenger	L	-	-	L <sup>(1)</sup>	L <sup>(1)</sup>	L <sup>(1)</sup>	R
	Centre	-	-	-	L <sup>(1)</sup>	L <sup>(1)</sup>	L <sup>(1)</sup>	R <sup>(3)</sup>
Second row	Outboard	-	-	-	L <sup>(1)</sup>	L <sup>(1)</sup>	L <sup>(1)</sup>	R <sup>(3)</sup>
	Centre	-	-	-	L <sup>(1)</sup>	L <sup>(1)</sup>	L <sup>(1)</sup>	R <sup>(3)</sup>
Other rows	Outboard	-	-	-	L <sup>(1)</sup>	L <sup>(1)</sup>	L <sup>(1)</sup>	R <sup>(3)</sup>
	Centre	-	-	-	L <sup>(1)</sup>	L <sup>(1)</sup>	L <sup>(1)</sup>	R <sup>(3)</sup>



Table 7.4 NB2 – Medium Goods Vehicle (GVM exceeding 4.5 tonnes but not 12 tonnes)

		ADR 32	ADR 32A	ADR 5/00	ADR 5/01	ADR 5/02	ADR 5/03	ADR 5/04	ADR 5/05
Vehicle built between		1 July 1977 → 30 June 1987	1 July 1987 → 30 June 1988	1 July 1988 → 30 June 1990	1 July 1990 → 30 June 1992	1 July 1992 → 30 June 1996	1 July 1996 → 31 December 1999	1 January 2000 → 30 June 2008	1 July 2008 →
Front row	Driver	L	L	L	L	R	R	R	R
	Outboard passenger	L	L	L	L	R	R	R	R
	Centre	-	-	-	-	L	L	L	R <sup>(4)</sup>
Second row	Outboard	-	-	-	-	L	L	L	L
	Centre	-	-	-	-	L	L	L	L
Other rows	Outboard	-	-	-	-	L	L	L	L
	Centre	-	-	-	-	L	L	L	L

Table 7.5 NC – Heavy Goods Vehicle (GVM exceeds 12 tonnes)

		ADR 32	ADR 32A	ADR 5/00	ADR 5/01	ADR 5/02	ADR 5/03	ADR 5/04	ADR 5/05
Vehicle built between		1 July 1977 → 30 June 1987	1 July 1987 → 30 June 1988	1 July 1988 → 30 June 1990	1 July 1990 → 30 June 1992	1 July 1992 → 30 June 1996	1 July 1996 → 31 December 1999	1 January 2000 → 30 June 2008	1 July 2008 →
Front row	Driver	L	L	L	L	L-R	L-R	L-R	R
	Outboard passenger	L	L	L	L	L-R	L-R	L-R	R
	Centre	-	-	-	-	L	L	L	R <sup>(4)</sup>
Second row	Outboard	-	-	-	-	L	L	L	L
	Centre	-	-	-	-	L	L	L	L
Other rows	Outboard	-	-	-	-	L	L	L	L
	Centre	-	-	-	-	L	L	L	L

**Key:**

- L Lap type seatbelt
- L-R Lap type seatbelt with a retractor
- R Lap-sash type seatbelt with a retractor
- (1) Other than route service omnibus, anchorages required for non-protected
- (2) If a protected seat, lap anchorages are acceptable
- (3) A lap type seatbelt may be acceptable if the vehicle is configured and certified to comply with UNECE Regulation 80
- (4) A lap type seatbelt may be acceptable if the vehicle's windscreen is in the seating reference zone as per UNECE Regulation R16/06 called up under ADR 4/05
- (5) If the vehicle complies to ADR 68/00, requirements only apply to the driver's seat.

**General Notes:**

- (i) See ADRs 4/-- and 5/-- for seatbelt and seatbelt anchorage requirements
- (ii) See ADR 68/-- for child restraint and child restraint anchorage (CRA) requirements
- (iii) Lap seatbelts are acceptable if there is no suitable permanent structure above and to the rear of the seating positions of some vehicles
- (iv) Lap seatbelts are acceptable for the third and further rows of seats of some vehicles if the seat is adjustable for conversion to luggage or goods space. See ADRs 4/-- and 5/-- for more information
- (v) Side facing seats may only be fitted with a lap seatbelt.



## Section 8

# Lights and Reflectors

### Objective:

To ensure that all compulsory lights, reflectors and other electrical lighting components as required by prescribed standards are operational.

### Australian Design Rules relevant to this section:

- ADR 1** Reversing lamps
- ADR 6** Direction indicators
- ADR 13** Installation of lighting and light-signalling devices on other than L-group vehicles
- ADR 44** Specific purpose vehicle requirements
- ADR 45** Lighting and light-signalling devices not covered by ECE regulations
- ADR 46** Headlamps
- ADR 47** Retroreflectors
- ADR 48** Devices for illumination of rear registration plates
- ADR 49** Front and rear position (side) lamps, stop lamps and end-outline marker lamps
- ADR 51** Filament lamps
- ADR 58** Requirements for omnibuses designed for hire and reward
- ADR 74** Side marker lamps
- ADR 75** Headlamp cleaners
- ADR 76** Daytime running lamps
- ADR 77** Gas discharge headlamps
- ADR 78** Gas discharge light sources

**Note:** In this section the description 'yellow' is used as a more modern term instead of the description 'amber' which is used in earlier legislation and some ADRs.

In this section the description 'parking lights' is used as a more modern term instead of the description 'front position lamps' which is used in earlier legislation and some ADRs.

## 8.1 Check lights and reflectors

### Reasons for rejection

- a) Compulsory reflectors are damaged, obscured, deteriorated, not installed in the correct location or are not fitted
- b) Any of the following lights are inoperative, obscured, deteriorated, insecure or not fitted where required, or are an incorrect colour:
- headlight (high/low beam) (white)
  - daytime running lights (white)
  - front fog lights (white or yellow)
  - front park lights (white)
- Note:** A front park light may be yellow if the light functions as a front park light and side marker light.
- tail lights (red)
  - brake lights (red)
  - reversing lights (where fitted, mandatory on motor vehicles after 30/06/1975) (white)
  - direction indicator lights (yellow)
  - clearance/end-outline marker lights (white/yellow to front, red to rear)
  - number plate light (white)
  - side marker lights (yellow or yellow to front, red to rear)
  - compulsory tell-tale lights
  - step lights (for buses), except in the case of an external access step to a single row of seats for a small bus having a seating capacity of not more than 15 adults, including the driver
  - interior bus lights.
- c) Any reflector on the vehicle, other than conspicuity markings:
- show white to the side or rear
  - show red to the side or front
- Note:** The rearmost side reflector can be red if it is grouped with the rear position lamp, the rear end-outline marker light, the rear fog light, the stop light, the red rearmost side-marker light or the rear retro-reflector.
- show yellow to the front or rear
  - show a colour other than red, yellow or white.
- d) Daytime running lights are not wired so:
- they are off when a headlight, other than a headlight being used as a flashing signal, is on, or
  - if included as part of a combination light, they dim when a headlight other than a headlight being used as a flashing signal, is on.
- e) More than two daytime running lights are fitted
- f) Daytime running lights fitted to a vehicle built from 1 October 1991:
- are not white
  - are less than 250mm or more than 1500mm from the ground, or
  - on a vehicle that is at least 1300mm wide, the distance between the inner edge of the lights is not at least 600mm, or
  - on a vehicle that is less than 1300mm wide, the distance between the inner edge of the lights is not at least 400mm
- g) Daytime running lights fitted to a vehicle built prior to 1 October 1991:
- Are not white or yellow
  - are installed so the centre of light is more than 510mm from the nearer side of the vehicle
  - on a vehicle that is at least 1300mm wide, the distance between the inner edge of the lights is not at least 600mm
  - on a vehicle that is less than 1300mm wide, the distance between the inner edge of the lights is not at least 400mm
- h) Any rear light other than a reversing light is installed or damaged to the extent that white light shows
- i) Any yellow clearance light or front turn signal is damaged so that it shows white light (except vehicles prior 7/73)
- j) The number plate light is not directing light onto the surface of the rear number plate
- k) Any optional light or reflector interferes with the effective operation of any compulsory light or reflector
- l) Any light has a tinted cover over it that affects its intended operation
- m) Any light that is not clearly visible under all normal conditions and of a consistent intensity, and are affected by dirty or damaged lenses or poor electrical contact
- n) Lenses and light reflectors are not securely mounted, are faded or discoloured and are not free from cracks, holes, or other damage which would allow the entry of moisture or dirt to impair the efficiency of the light or reflector
- o) There is any other type of opaque cover over a headlight which cannot be readily removed
- p) A bus that is not a school bus is fitted with either the lights and/or signs required by the school bus warning system
- Note:** Refer to Section 13 Buses, for further information on school bus warning systems.
- q) Lighting does not comply with the *Heavy Vehicle (Vehicle Standards) National Regulation*
- r) All low beam headlights with a luminosity of more than 2000 lumens are not self-levelling and self-cleaning

- s) More than four driving lights are fitted
- t) Driving lights or additional headlights are not installed symmetrically about the centre of the vehicle
- u) For an LED type light more than 30% of the individual LEDs do not function.

**Note:** For example, if an LED light bar is made up of 10 LEDs, at least seven of the LEDs must be working. If only six LEDs work, this is a reason for rejection.

## 8.2 Check headlights

### Reasons for rejection

- a) Headlight reflector is tarnished or peeling to the extent that headlight performance is impaired
- b) Headlight lens is cracked or broken
- c) Headlight assembly is not secured or is out of position
- d) Headlight does not project white light
- e) Headlight lens or reflector is internally contaminated by dirt or moisture
- f) A device to indicate to the driver that the headlights are in the high beam position is not fitted and operational
- g) A dipping device to change the headlights from the high beam position to the low beam position and operated from the normal driving position is not fitted and operational
- h) Headlights do not comply with the *Heavy Vehicle (Vehicle Standards) National Regulation*.

## 8.3 Check headlight aim (includes driving lights and alternative headlights)

This section should be read in conjunction with the equipment manufacturer's instructions.

### Reasons for rejection

- a) The aim of the headlight is adjusted such that, when on high beam and measured at an effective distance of 8 metres, the projected centre of the beam is to the right of the headlight centre and/or is above the headlight centre
- b) When measured at an effective distance of 8 metres, any part of the top edge of the high intensity portion of the low beam pattern is above, and to the right of the centreline of the headlight.

**Note:** In the region above and to the right of the centreline of the headlight the luminous intensity must not exceed 437 candela.

*The portion of the beam to the left of the centreline of the light may extend above the height of the centreline of the headlight.*

*The centreline of the headlight passes through the centre of the globe filament, or equivalent.*

For information regarding headlight testing screens, refer to Additional Information – Headlight Testing Screens.

## 8.4 Backlit badges

### Reasons for rejection

- a) The light source is not integrated within, and contained totally within, the badge/logo
- b) The badge/logo shows:
  - white to the rear of the vehicle
  - red to the front of the vehicle
  - a colour other than red, white or yellow
- c) The luminous intensity is more than 60 candela
- d) The light flashes
- e) The badge/logo and light source is within 200mm of another lamp
- f) The light can be seen, either directly or by reflection, by the driver when in the normal seated driving position
- g) The light source is not connected so that it only operates with the front lighting system
- h) The light is overly large so as to affect the prominence of other mandatory lamps.

## 8.5 Check conspicuity markings

Conspicuity markings are optional reflective markings that can be fitted to a heavy vehicle intended to improve visibility of the vehicle.

### Reasons for rejection

- a) Reflective material used for conspicuity markings:
  - shows white to the rear
  - shows red to the side or front
  - shows yellow to the front
  - shows a colour other than red, yellow or white.
- b) Markings do not continue for at least 80% of the length or width of the vehicle
- c) Markings on the side of the vehicle do not come within at least 600mm of the front or rear of the vehicle
 

**Note:** The markings do not need to continue in the gap between the cabin and the body
- d) The lowest part of the markings is less than 250mm or more than 1500mm from the ground

**Note:** Where the design of a vehicles does not allow for fitting within 1500mm, the marking may be fitted up to 2100mm from the ground



- e) For full or partial contour markings that are fitted to the side of the vehicle, markings at the top are more than 400mm from the upper extremity of vehicle
- f) For full or partial contour markings that are fitted to the rear of the vehicle, markings:
  - on the sides of the vehicle are more than 400mm from the outer edge of the vehicle
  - at the top of the vehicle are more than 400mm from the upper extremity of vehicle
- g) Markings do not comply with Australian Design Rule 13/..

For additional information regarding conspicuity markings, refer to the Australian Trucking Association’s Technical Advisory Procedure on Heavy Vehicle Visibility.

## Additional Information – Headlight Testing Screens

### 1 Scope

1.1 This specification describes requirements for the headlight testing screen and the layout of the headlight testing space.

### 2 Headlight testing screen

2.1 The surface of the screen should be ‘flat’ white (gloss finish should be avoided). The screen shall be at least 1300mm in height and 2400mm in width and shall be marked with horizontal and vertical lines. Horizontal lines shall be spaced 75mm apart and vertical lines shall be spaced 300mm apart. Horizontal lines shall be labelled with their height starting from the bottom of the screen.

Figure 8.1 Headlight testing screen

1275							
1200							
1125							
1050							
975							
900							
825							
750							
675							
525							
450							
375							
300							
225							
150							
75							

FRONT ELEVATION OF SCREEN

Level of surface upon which the vehicle is standing during test.

**Note:** All lines to be black except centre vertical which is to be red. The thickness of all lines is to be as small as possible and consistent with good visibility for an observer at a distance of 8 metres from the screen during test of headlights. The heights of the horizontal lines above the level of surface upon which vehicle is standing during test are to be clearly marked with black figures, as shown, of a size to ensure good visibility for an observer at a distance of 8 metres from the screen during test of headlights.

### 3 Layout of the testing space

- 3.1 The ground on which the vehicle stands shall be marked with a centreline which passes through the centreline of the screen and a transverse line which intersects the centreline and is 8000mm from the screen (the headlights of the tested vehicle are positioned directly over this line). Additional longitudinal lines in the region where the vehicle standing would assist alignment and their use is recommended.
- 3.2 The bottom of the screen is at the same level as the surface on which the vehicle stands.
- 3.3 The screen and testing space must be adequately shielded from extraneous light.
- 3.4 The testing space must be clear of obstruction.

Figure 8.2 General arrangement of the headlight testing space

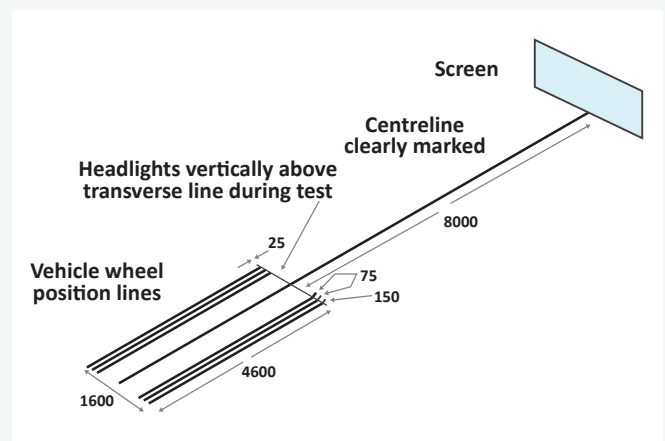

**Note:** All dimensions in the diagram are in millimetres.

## Section 9

# Mirrors

### Objective:

To ensure that the mirrors and associated components are in such a condition that the driver has a clear field of vision at all times under the normal range of climatic conditions.

Australian Design Rules relevant to this section:

**ADR 14** Rear vision mirrors

**ADR 58** Requirements for omnibuses designed for hire and reward

### 9.1 Check mirrors

#### Reasons for rejection

- Any reflective surface of a compulsory rear view mirror:
  - has a missing section
  - is cracked
  - is deteriorated, blemished or tarnished reducing the view to the rear of the vehicle
  - is obscured.
- Side mirrors do not have a surface of at least 150cm<sup>2</sup> (e.g. 10cm by 15cm)
- Mirrors are not securely mounted or missing
- Side mirrors are not fitted to both sides of the motor vehicle
- Any compulsory mirror does not provide a clear view of the road to the rear of the vehicle
- Non-folding mirrors protrude more than 150mm beyond the overall width of the vehicle

- Folding side mirrors protrude more than:
  - 230mm beyond the overall width of the vehicle when not folded
  - 150mm beyond the overall width of the vehicle when folded

**Note:** Convex mirrors that meet the vision requirements of the UNECE Regulation 46 are acceptable.

UNECE R46 allows external rear vision mirrors to exceed 230mm, however no more than necessary to achieve the field of view as shown in Figure 9.1.

- a blind spot mirror protrudes more than 150mm forward of the vehicle

Figure 9.1 Mirror field of vision requirements

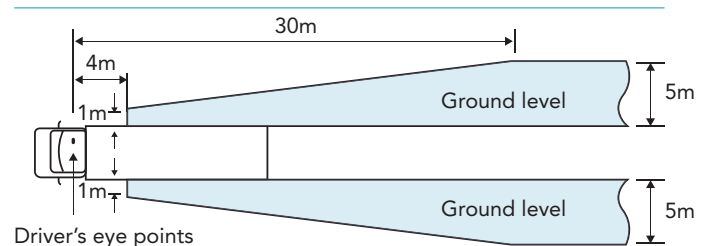







## Section 10

# Windscreens and Windows

### Objective:

To ensure that the windscreen, windows and associated components are in such a condition that the driver has a clear field of vision at all times under the normal range of climatic conditions.

Australian Design Rules relevant to this section:

- ADR 8** Safety glazing material
- ADR 15** Demisting of windscreen
- ADR 16** Windscreen wipers and washers
- ADR 42** General safety requirements

### 10.1 Check windscreen and windows

#### Reasons for rejection

- a) The wiped area of the windscreen in front of and on the same side of the vehicle as the driver, (shown in Figure 10.1 as area A), has:
  - damage (such as scoring, sandblasting or severe discolouration) that interferes with the driver's view
  - any bulls-eye or star fracture that exceeds 16mm in diameter, or either of the following:
    - hairline crack exceeding 30mm long
    - a crack from the edge of the windscreen exceeding 75mm long.

**Note:** Grooves in windscreens that are designed specifically to clean the wiper blades are not regarded as damage unless they affect the driver's view. Approved grooving is usually identified by the installer.

The fitment of windscreen stone shields is permitted provided the driver's view of the road to the front and side of the vehicle is not reduced.

For further information on windscreens, refer to Additional Information – Replacing or Repairing Windscreens.



Figure 10.1 Driver's field of vision

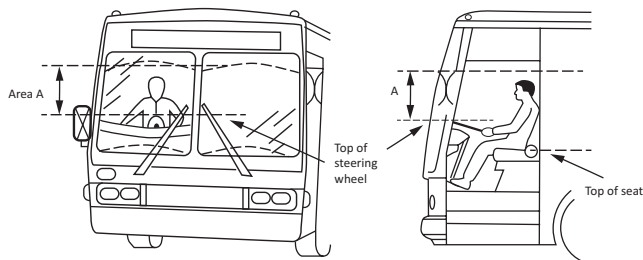
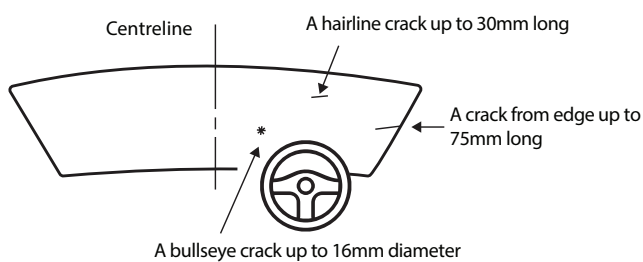

Figure 10.2 Cracks in field of vision



- b) Any cracks in a laminated windscreen penetrate more than one layer of glass or are more than 150mm long
- c) Any glazing used in any motor vehicle is not safety glass and where ADR 8 applies, the glass does not display an identification mark or symbol
- d) Glazing is loose in its frame or cracked to the extent that sharp edges are exposed
- e) Glazing, other than the windscreen, that is necessary for the driver to see the road is discoloured, obscured, badly scratched, sandblasted or fractured to the extent that it interferes with the driver's view
- f) Items that obscure the driver's view are placed in area A shown in Figure 10.1 or the corresponding area on the other side of the windscreen with the exception of a driver's aid
 

**Note:** A driver's aid is a visual display unit that assists the driver of the vehicle. Driver's aids include dispatch systems, navigational equipment (e.g. GPS), rear view screens, ticket-issuing machines and vehicle-monitoring devices.
- g) At least half the number of windows must be capable of being opened or the vehicle must be provided with an alternative method of ventilation
- h) Windscreens are removed and not replaced
- i) For a bus that is not adequately ventilated by means of a fan forced 'jet air' or fan forced air-conditioning system, moveable windows are not fitted with a suitable device for opening and closing

- j) If a bus does not have ventilation additional to that provided by its windows
- k) Ladder racks, external roll bars and cages, or similar accessories:
  - have uprights with a diameter of more than 50mm, or
  - are positioned in a way that can reflect the vehicle's lights into the drivers eyes and they do not have a matt, non-reflective black finish.

## 10.2 Test the light transmittance level of the windscreen, side and rear windows

This section should be read in conjunction with the light meter manufacturers' instructions.

The light meter may have up to a 5% measuring inaccuracy. A vehicle may be accepted if the readings are up to 5% lower than the minimum light transmittance.

In this section, the term tinting refers to both a film applied to glazing to reduce the luminous transmittance and 'tinted glass' where the glazing is manufactured with tinting material between the layers of glass.

### Reasons for rejection

- a) Any windscreen glazing has any coating which reduces its light transmittance
 

**Note:** Coating that reduces light transmittance may be fitted to either the area above the highest point of the windscreen that is swept by a windscreen wiper or the upper 10% of the windscreen, whichever is greater.
- b) The visible light transmittance of any glazing (including any applied film) is less than that detailed in Table 10.1
- c) Tint films are not free of bubbles, scratches or other defects that significantly affect the driver's vision
- d) Tint films have a reflectance in excess of 10% (e.g. mirror tints)
- e) Not fitted with exterior rear view mirrors on both sides of the vehicle.

Table 10.1 Light transmittance requirements

Glazing	Minimum light transmittance	Vehicles NOT TO BE REJECTED until meter readings are LESS than
Windscreen	70%	65%
All other windows (no tinting)	70%	65%
All other windows level with or forward of the drivers seated position (with tinting)	35%	30%
All other windows (with tinting)	0%	0%

Figure 10.3 Window tinting requirements

Trucks



Buses - 10 or more seating positions



- ★ **Windscreen**
  - No film at all allowed on the lower part of the windscreen
  - Minimum 70% VLT
  - Tinted or opaque band allowed at the top of the windscreen. It is not to extend below the portion swept by the wipers or 10% of the depth of the windscreen
- **Windows**
  - Minimum 35% VLT
  - Must be no more than 10% reflective
  - Film must not be damaged, bubbled or discoloured
- **Windows rearward of driver**
  - No minimum VLT specified for rear windows
  - Must be no more than 10% reflective

### 10.3 Check windscreen wipers, demisters and washers

#### Reasons for rejection

- The windscreen wipers are not operational at all speeds and do not return to their normal parked position
- Wiper blade rubbers are cracked, hardened, frayed, curled, torn or missing
- Windscreen washers are inoperative or incorrectly aimed (where applicable)
- Windscreen demister is inoperative or does not blow air onto the windscreen (where applicable)
- The windscreen washer and wipers are not able to be operated from a normal driving position.

## Additional Information – Replacing or Repairing Windscreens

### Introduction

Windscreen damage or defects may impair a driver's forward vision, create a potential safety hazard and affect road safety. However, windscreens will be subject to some damage such as sandblasting, cracks, and stone chips during normal operation, therefore some deterioration from new condition is allowable.

A windscreen should be clean and free of damage that might impair the driver's view to the front of the vehicle.

### Is a damaged windscreen safe?

When a damaged windscreen is examined the following factors should be considered:

- the location of the damage
- the size of the damage
- effect on the mechanical strength of the windscreen.

To determine if a windscreen should be replaced or repaired, the area of windscreen swept by the wipers may have bullseyes and star fractures up to 16mm in diameter and cracks up to 150mm long which do not penetrate more than one layer of the glass in a laminated windscreen, provided they do not interfere with the driver's vision.

In addition, the 'primary vision area' (the area of the windscreen which is swept by the windscreen wipers) must not be cracked, scored, chipped, sandblasted or otherwise damaged to the extent that it impairs the driver's vision or damages the wiper blades.

It is recommended that all defects be repaired as soon as possible.

Figure 10.4 Cracks in field of vision

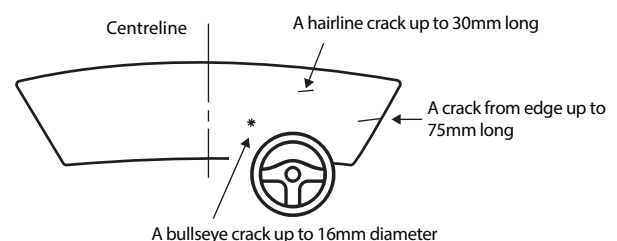

### Repairing windscreen damage

Repairing a damaged windscreen, if undertaken correctly, is an acceptable means of reinstating a windscreen to a safe condition.

Repaired windscreens must comply with the following requirements:

- when inspected from the inside of the vehicle, the repair should not exhibit any significant optical defects which would distort or distract the vision of the driver and should restore clarity to the damaged area. (Acceptable limits of repairs are outlined in Note 1)
- any repair to the windscreen should not reduce the effectiveness of the windscreen wipers
- windscreen repair material must be used in accordance with the manufacturer's instructions.

If a repair has been unsuccessful or is unlikely to be effective, the vehicle owner is responsible for replacing the windscreen in order to meet the necessary safety requirements.

**Note:** In a repaired windscreen, a faint outline of the repair, or in some cases, a slight dull spot may be visible where the repair has been performed. A repaired crack may also be detectable by a fine hairline surface mark. These are acceptable and should not cause a vehicle to fail an inspection provided the damaged windscreen has been repaired to a standard which complies with the requirements outlined in this document.

To date, the extent of windscreen damage considered to be repairable has not been defined. Improved technology has increased the scope of repairable damage and acceptability can only be determined (in accord with the above standards) after the repair has been completed.

It is recommended that repairs of cracks longer than 350mm be avoided.

The Australian Standard AS 2366 Repair of laminated glass windscreens fitted to road vehicles is a voluntary code of practice for the repair of automotive windscreens that gives recommended practices regarding the repair of laminated windscreens. The use of the Australian Standard is not mandatory.

## Replacement windscreens

To ensure the safety of all motor vehicle occupants, replacement windscreens must be of an approved safety glass.

The glass must always bear an identification mark indicating the standard to which the glass has been manufactured (e.g. AS 2080, BSAU178, JISR3211, UNECE R43, ANSI-Z26.1) and have a standards mark etched or indelibly printed on the glass.

Windscreens which do not comply with these recognised standards may shatter easily and unexpectedly, creating areas of distorted vision.

Windscreens that do not have a standards mark are illegal.

Windscreens fitted (either new or as a replacement) to motor vehicles manufactured on or after 1 July 1971, are required by law to be made from glass which has a light transmittance of no less 75%. Aftermarket tint film may be applied to the upper portion of the windscreen. The tinting must not extend lower than a horizontal line contacting the uppermost point of the arcs swept by the vehicle manufacturer's original wiper blades. The tinting may be of any shade but must not have a reflectance of more than 10%.

## Types of windscreens available



There are two types of replacement windscreens available for motor vehicles, laminated or tempered.

Laminated glass windscreens are manufactured like a sandwich with glass on the outside and inside surfaces and a clear plastic film between. A laminated screen is more resistant to breakage than tempered glass and even when fractured it remains almost transparent.

Tempered glass is specially treated so that, when broken, it shatters into tiny fragments instead of jagged splinters. Unfortunately, when the windscreen shatters, it is difficult to see through.

Motor vehicles manufactured on or after 1 January 1994 must be fitted with laminated glass windscreens. Whilst motor vehicles built before 1 January 1994 do not have to meet this requirement, it is strongly recommended that when a replacement windscreen is needed, laminated glass be used.

## Remember

Windscreen damage or defects could seriously impair a driver's ability to see clearly, thereby presenting a safety hazard.



## Section 11

# Engine, Driveline and Exhaust

### Objective:

To ensure the engine, driveline and associated components provide a controlled transmission of power to the driving wheels.

### Australian Design Rules relevant to this section:

- ADR 42** General safety requirements
- ADR 44** Specific purpose vehicle requirements
- ADR 58** Requirements for omnibuses designed for hire and reward
- ADR 65** Maximum road speed limiting for heavy goods vehicles and heavy omnibuses
- ADR 80** Emission control for heavy vehicles
- ADR 83** External noise

### 11.1 Check exhaust system

#### Reasons for rejection

- a) Any component of the exhaust system is not securely mounted
- b) The exhaust system does not incorporate an effective silencing device that all exhaust gases pass through
- c) The exhaust system contacts any unrelated part of the vehicle
- d) The exhaust outlet on a heavy motor vehicle, other than a bus or goods carrying vehicle with a GVM less than 12 tonnes, does not extend:
  - beyond the rear most seating position, and
  - at least 40mm past the outermost joint of the floor pan that is not continuously welded or permanently sealed, or
  - where the body of the vehicle is permanently enclosed and not fitted with a vertical exhaust system, to the edge of the vehicle.
- e) The exhaust outlet on a bus:
  - is not as near as practicable to the rear of the vehicle
  - extends past the edge of the vehicle at its widest point
- f) Exhaust pipe outlet is not rearward of all rear passenger doors or sleeper compartment that may allow the ready entrance of exhaust gases
- g) There is any leak in the exhaust system (excluding manufacturers' drain holes in the mufflers)



- h) A vertical exhaust does not extend at least 150mm above the cab of the vehicle.
- i) The outlet on a vertical exhaust does not discharge the exhaust flow straight up:
  - at an angle above the horizontal; and
  - towards the rear, or right, of the vehicle
- j) A catalytic converter and/or particle filter is missing, bypassed or has a missing heat shield
 

**Note:** Not all heavy vehicles are built with heat shields, catalytic converter and/or particle filters.
- k) Any exhaust component that fouls any part of the steering, suspension, brake or fuel system
- l) Any part of the exhaust system liable to be contacted by a person touching or leaning on vehicle that is not protected by a suitable guarding
- m) For a bus, flammable material is located 100mm of the exhaust without shielding.

## 11.2 Check noise emissions

Where it is evident that a vehicle is emitting significantly higher noise than normal, the vehicle must not pass the inspection. The operator must be referred to a facility where a stationary noise test must be conducted in accordance with Table 11.1.

For a vehicle that has a silencing device designed to be adjusted by the vehicle's operator, the device must be tested in the worst-case configuration.

This section must be read in conjunction with *National Stationary Exhaust Noise Test Procedures for In-Service Motor Vehicles* which can be obtained from the National Transport Commission website at [www.ntc.gov.au](http://www.ntc.gov.au)

### Reasons for rejection

- a) Any noise reducing or absorbing equipment is missing

**Note:** Changes to the original design of the engine, fuel system, air inlet system, or exhaust system all have the potential to affect compliance of the vehicle with noise standards. Where any such modifications have been carried out a noise test may be necessary to ensure that the vehicle complies with the exhaust noise limits.

Such modifications could also affect compliance with exhaust emission requirements and the operator may be directed to have the vehicle tested.

- b) For a vehicle certified to comply with ADR 83, the vehicle exceeds the certified noise level for the vehicle by more than 5dB(A)

**Note:** Stationary noise level values for vehicles can be found on the Road Vehicle Certification System website: <http://rvcs.infrastructure.gov.au>

- c) For a vehicle not certified to comply with ADR 83, the noise level from the vehicle exceeds the figure in Tables 11.1 or 11.2 (as applicable).

Table 11.1 Noise limits for diesel-powered heavy vehicles

Gross Vehicle Mass (kg)	Height above ground of end of exhaust pipe (mm)	Manufacture period	Noise level dB(A)
More than 4500, but not more than 12,000	1500 or more	Before 1/7/80	103
		On or after 1/7/80 and before 1/7/83	100
		On or after 1/7/83	97
More than 4500, but not more than 12,000	less than 1500	Before 1/7/80	107
		On or after 1/7/80 and before 1/7/83	104
		On or after 1/7/83	101
More than 12,000	1500 or more	Before 1/7/80	105
		On or after 1/7/80 and before 1/7/83	102
		On or after 1/7/83	99
More than 12,000	less than 1500	Before 1/7/80	109
		On or after 1/7/80 and before 1/7/83	106
		On or after 1/7/83	103

**Note:** Appropriate tolerances on noise values should be applied.

**Table 11.2** Noise limits for heavy vehicles with spark ignition engines

Height above ground of end of exhaust pipe (mm)	Manufacture period	Noise level dB(A)
Less than 1500	Before 1/7/83	98
	On or after 1/7/83	95
1500 or more	Before 1/7/83	94
	On or after 1/7/83	91

**Note:** Appropriate tolerances on noise values should be applied.

### 11.3 Check engine and driveline

#### Reasons for rejection

- a) Engine and driveline mounts or driveline components are loose, cracked, broken or are missing components or fasteners
- b) A bus fitted with a transmission that incorporates a longitudinal drive shaft is not fitted with a device that prevents the front of the drive shaft from contacting the road in the event of becoming detached from its normal position (tail shaft guard)
- c) Any universal joint or securing bolts are loose or missing
- d) Constant velocity joints, universal joints, support bearings, splines, and other driveline components are not secure, excessive wear, back lash (as per manufacturer's specifications) or seizure which could cause component failure
- e) Engine and transmission controls are inoperative
- f) A vehicle fitted with an automatic transmission is capable of being started when the transmission control is in a position to drive the vehicle
- g) A vehicle fitted with a compression ignition engine (diesel) that is not fitted with a device that prevents the engine from inadvertently being started
- h) Seals on covers between the engine and the passenger compartment are missing, distorted or damaged in a way that allows fumes to enter the passenger compartment
- i) Engine emits excessive smoke for at least 10 seconds continually at or near the discharge end of the exhaust pipe
- j) Vehicles manufactured with emission control devices do not have all emission control equipment properly located, connected or are damaged, deteriorated or altered in any way to reduce effectiveness

**Note:** Modifications to emission equipment can affect smoke emission.

- k) Crankcase gases escape into the atmosphere (applies to petrol engines fitted with positive crankcase ventilation only)
- l) The engine lets out sparks, flames, oil or fuel residue
- m) Air cleaners are not fitted
- n) Fuel injection equipment, engine speed governor or any other part of an engine is adjusted so that it increases smoke
- o) The following types of vehicles, which must comply with ADR 65, the maximum road speed limiting is greater than 100km/h or there is evidence of tampering or modification of road speed limiting device:

- a bus with a GVM over 14.5 tonnes that was built after 1987 must comply with third edition ADR 65
- a prime mover with a GVM over 15 tonnes that was built after 1987 must comply with third edition ADR 65.

**Note:** Rejection reason (o) does not apply to:

- an ambulance, police vehicle or Australian Defence Force vehicle; or
- a vehicle built or permanently modified for fire fighting or emergency rescue purposes, or
- a bus fitted with hand grips or similar equipment for standing passengers to hold, or
- a two-axle prime mover if:
  - 1) it was built after 1987 but before July 1991, and
  - 2) its operator is a person who uses it for agriculture, horticulture or other primary production activities, except forestry, fishing and mining.

- p) If a vehicle manufactured after 1 July 1988 is not fitted with an operational speedometer, which indicates vehicle speed only in kilometres per hour
- q) If a vehicle manufactured after 1 July 1988 but before 1 July 2006 is not fitted with an operational odometer, which indicates distance travelled in 1 kilometre units (or less) from 1 to 999,999 kilometres.

**Note:** Adjustments or modifications to components of the fuel system have the potential to affect compliance of a vehicle with emission standards. The manufacturer's advice should be sought to ensure the vehicle is kept within prescribed limits. A test to determine compliance with National Diesel Emission Standards may be undertaken in jurisdictions that have the necessary test equipment.

## 11.4 Check oil leaks

### Reasons for rejection

- a) Oil leaks from the engine, gearbox, differential, brake system, power steering or any joint or seal:
  - on to brake friction surfaces, or
  - on to the exhaust system, or
  - on to the road surface.

## 11.5 Check fuel tanks and system (non LPG/NG)

### Reasons for rejection

- a) Any leakage from the fuel system
- b) Fuel lines are in contact with moving parts or a heat source, are kinked, cracked or not secure
- c) Fuel tanks are not securely mounted, straps, supports, mounting brackets or fasteners are missing, cracked, broken or loose
- d) Fuel filler cap is missing or not suitable for the type of tank
- e) Fuel filler cap seal is damaged or missing.

## 11.6 Visually inspect fire extinguisher

This section only applies to a vehicle if it is mandatory for the vehicle to carry a fire extinguisher.

### Reasons for rejection

- a) Fire extinguisher is not filled, charged or under current inspection
- b) Handles, nozzles or hoses of fire extinguisher are missing or damaged
- c) The extinguisher is not securely mounted in the vehicle
- d) The extinguisher is not securely mounted in a readily accessible location in the vehicle in accordance with Australian Standard AS 2444 *Portable fire extinguishers – Selection and location*.

**Note:** *Fire extinguishers can become ineffective even though they appear properly charged. For example powder type extinguishers subject to vibration can fail due to compacting of the powder.*

*Australian Standard AS 1851.1 Portable fire extinguishers, contains suitable procedures for inspecting and testing fire extinguishers.*

*AS 2444 Portable fire extinguishers – Selection and location outlines the appropriate type, size and location of fire extinguishers for vehicles.*



## Section 12

# LPG, NG, Hydrogen and Electric Vehicles

### Objective:

To conduct a visual inspection of a liquefied petroleum gas (LPG)/natural gas (NG) fuel system and the associated components.

### Australian Design Rules relevant to this section:

**ADR 42** General safety requirements

**ADR 44** Specific purpose vehicle requirements

**ADR 80** Emission control for heavy vehicles

**Note:** ADR 80 applies to vehicles operating on LPG or NG with a GVM in excess of 3500kg as of 1 January 2004.

Compressed natural gas (CNG) is also known as natural gas for vehicles (NGV).

Natural gas (NG) means both CNG and liquid natural gas (LNG).

Hydrogen powered vehicle means a vehicle powered by and fitted with one or more hydrogen fuel containers

Electric powered vehicle means a vehicle that is powered by one or more electric or traction motors.

### Important note

The Australian Design Rules and Heavy Vehicle (Vehicle Standards) National Regulation requires gas fuel systems fitted to vehicles to comply with the relevant Australian Standards.

Inspection of a gas system as part of a vehicle safety inspection is a visual inspection only. Should a person inspecting a gas system have concerns over the system or require more information about gas systems, please contact a licensed gas fitter/installer in your state or territory.

If a gas system inspection is required for registration purposes, and a copy of a current gas system certificate issued by a licensed gas fitter/installer is provided, inspection of the gas system during the vehicle safety inspection is not necessary.



## 12.1 Visually inspect for the presence of an approved LPG or NG system identification

Visually inspect for the presence of an approved LPG or NG compliance plate and number plate labels.

A vehicle which has an LPG or NG fuel system fitted must have a metal plate (compliance plate) fitted in a prominent position near the installation, showing:

- a statement that the installation complies with the Standards Australia code for the fuel type (Australian/New Zealand Standard AS/NZS 1425 for LPG and Australian Standard AS 2739 for NG)
- the date the installation was commissioned
- the state or territory where installation was made
- the vehicle identification number (VIN) or chassis number
- the identification number of the suitably qualified installer.

There is no requirement for a modification plate to be fitted to a vehicle with an approved LPG or NG system unless structural modifications were undertaken to the vehicle to install the LPG or NG system.

### Reason for rejection

- a) Vehicle does not have an approved LPG or NG compliance plate. Acceptable plates are either:
- A plate fitted by a state or territory authorised/licensed gas fitter/installer, or
  - A plate fitted by the vehicle manufacturer, where the LPG or NG system was installed by the original vehicle manufacturer.

The following are examples of acceptable compliance plates that have been fitted by vehicle manufacturers:

Figure 12.1 Acceptable LPG or NG compliance plate examples for in-service fitsments

**LIQUIFIED PETROLEUM GAS COMPLIANCE PLATE**

The autogas installation to which this notice is affixed complies with the requirements of Australian/New Zealand Standard AS/NZS 1425.

INSTALLATION DATE ..... STATE .....

COMPLIANCE NO .....

INSTALLED BY .....

NAME ..... LIC/AUTHORIZATION NO .....  
(REP. NO.)

WORKSHOP NO .....

VIN NO.....

CONTAINER(S) SERIAL NO(s).....

CONTAINER TEST STATION STAMP DATE.....

**NG COMPLIANCE PLATE**

The NG installation to which this notice is affixed complies with the requirements of AS/NZ 2739

INSTALLATION DATE ..... STATE INSTALLED .....

COMPLIANCE NO .....

INSTALLED BY .....

NAME ..... LIC/AUTHORIZATION NO .....

VEHICLE NO .....

Figure 12.2 Acceptable LPG or NG compliance plate examples for OEM fitsments

LOGO

MANUFACTURER

THE LPG SYSTEM COMPLIES WITH ADR44/01 & AS1425-1989  
INSTALLED BY LICENCED WORKSHOP No. AFR 00050  
V.I.N. \_\_\_\_\_  
ENGINE No. \_\_\_\_\_ DATE / /  
L.P.G SERIAL No. \_\_\_\_\_

**LPG INSTALLATION MANUFACTURER  
MODEL MODEL**

INSTALLATION REFERENCE No. \_\_\_\_\_  
DATE OF INSTALLATION / / STATE/TERRITORY \_\_\_\_\_





THIS INSTALLATION COMPLIES WITH ADR44/01, AS1425-1989 AND  
○ MANUFACTURER'S INSTALLATION REQUIREMENTS ○

ODOMETER \_\_\_\_\_  
V.I.N \_\_\_\_\_  
ENGINE No. \_\_\_\_\_  
WORKSHOP \_\_\_\_\_ (LICENCE No.)  
FITTER \_\_\_\_\_ (CERTIFICATE No.)

- b) For installations after 1999, a vehicle does not have acceptable, durable and reflective number plate labels fitted to the front and rear of the vehicle indicating it is LPG or NG fuelled.

Acceptable number plate labels are shown in Figure 12.3.

Figure 12.3 Acceptable LPG, NG, Hydrogen or Electric number plate label examples

	<p>For vehicles fuelled with LPG:</p> <p>(a) The metal plate and label size shall be not less than 25mm square mounted as a diamond</p> <p>(b) The label colour shall be retroreflective red, complying with AS/NZS 1906.1, Class 2</p> <p>(c) The label shall have only the letters 'LPG' in white at least 10mm in height.</p>
	<p>For vehicles fuelled with CNG:</p> <p>(a) The metal plate and label size shall be a circle not less than 35mm diameter</p> <p>(b) The label colour shall be retroreflective red, complying with AS/NZS 1906.1, Class 2</p> <p>(c) The label shall have only the letters 'CNG' in white at least 10mm in height.</p>
	<p>For vehicles fuelled with LNG:</p> <p>(a) The metal plate and label size shall be a circle not less than 35mm diameter</p> <p>(b) The label colour shall be retroreflective standard green, complying with AS/NZS 1906.1, Class 2</p> <p>(c) The label shall have only letters 'LNG' in white at least 10mm in height.</p>
	<p>For vehicles fuelled with hydrogen:</p> <p>(a) The metal plate and label size shall be a regular pentagon shape each side of which is 20mm long</p> <p>(b) The label colour shall be retroreflective yellow, complying with AS/ NZS 1906.1, Class 2</p> <p>(c) It is marked 'H' in a black capital letter that is at least 10mm in height</p>
	<p>For vehicles fuelled with using electricity as a means of propulsion:</p> <p>(a) The metal plate and label size shall be an equilateral triangle shape each side of which is 30mm in length</p> <p>(b) The label colour shall be retroreflective blue, complying with AS/ NZS 1906.1, Class 2</p> <p>(c) It is marked 'EV' in white capital letters that are at least 10mm in height</p>

## 12.2 Visually inspect for the presence of an approved hydrogen number plate label

Visually inspect for the presence of approved hydrogen number plate labels.

Acceptable hydrogen number plate labels are shown in Figure 12.3.

### Reasons for rejection

- A vehicle manufactured or modified from 1 January 2019 does not have an acceptable, durable and reflective number plate label fitted to the front and rear of the vehicle indicating it is hydrogen fuelled.
- The number of labels on the front and rear number plates number do not correspond with:
  - 1 acceptable label on each number plate if the vehicle is fitted with 1 hydrogen fuel container; or
  - 2 acceptable labels on each number plate if the vehicle is fitted with 2 or more hydrogen fuel containers.

## 12.3 Visually inspect for the presence of an approved electric vehicle number plate label

Visually inspect for the presence of approved electric vehicle number plate labels.

Acceptable electric vehicle number plate labels are shown in Figure 12.3.

### Reasons for rejection

- A vehicle manufactured or modified from 1 January 2019 does not have an acceptable, durable and reflective number plate label fitted to the front and rear of the vehicle indicating its means of propulsion is electric powered/assisted.

## 12.4 Visually inspect the LPG or NG system

### Reasons for rejection

- The container has:
  - advanced corrosion or fire damage
  - cuts or dents which penetrate the surface of the container
  - any dent on the container which is deeper than 10% of the width of the dent, or which is located on a weld and exceeds 6.5mm in depth
  - any sharp impression or crease on the container which is longer than 75mm or is deeper than 25% of the wall thickness.
- The statutory life of the container has expired:
  - LPG every 10 years
  - NG steel containers every 5 years
  - Fibreglass reinforced plastic (FRP) containers every 3 years.

**Note:** It is a statutory requirement for an LPG or NG container to be checked for continued service life.

- c) Any metal parts contact the container (excluding clamping bands)
- d) The container:
  - is not securely restrained
  - is only restrained by a single strap
  - is restrained by straps that are damaged or have deteriorated
  - is not attached to the vehicle structure at least at 4 points.
- e) Wiring is not insulated or is secured at intervals of more than 600mm
- f) Where the vehicle body or chassis members do not provide protection for fuel lines under the vehicle, the piping is not shielded or encased in a protective sleeve

- g) If fitted the sleeving of any fuel line routed under the vehicle is damaged such that the fuel line is exposed
  - h) Any supporting clips (required to be spaced at intervals of 600mm) are missing or do not provide effective support to the fuel line
  - i) Any provision has been made to allow use of the gas fuel for purposes other than as automotive fuel
  - j) Any fuel lines, joints, connections or gas carrying components leak
- Note:** Extreme caution should be taken if a gas leak is identified. If possible shut/close-off the manual gas isolation valve and contact local emergency services.
- k) Any other component of the fuel system is cracked, broken, distorted, missing or corroded to the point where it is weakened or failure is likely to occur
  - l) The container or gas carrying components are located within 150mm of a heat source and there is no heat shield.



V2.4 February 2020





## Section 13

# Buses

### Objective:

To ensure that buses and associated components are fitted in accordance with the Vehicle Standards (including ADRs) and operate in a safe manner.

### Australian Design Rules relevant to this section:

- ADR 3** Seat and seat anchorages
- ADR 4** Seatbelts
- ADR 42** General safety requirements
- ADR 44** Specific purpose vehicle requirements
- ADR 58** Requirements for omnibuses designed for hire and reward
- ADR 59** Omnibus roll-over strength
- ADR 66** Seat strength, seat anchorage strength and padding in omnibuses
- ADR 68** Occupant protection in buses

*Note: The general roadworthiness of buses has been included within the standard vehicle inspection process outlined in each section.*

*This section deals only with those items that apply exclusively to buses.*

*Additional vehicle requirements may be imposed by jurisdictional passenger transport legislation. These requirements are not covered by this section.*

### 13.1 Check safety equipment and interior fittings

Any requirement for a fire extinguisher in this section only applies to a bus if it is mandatory for the bus to carry a fire extinguisher.

#### Reasons for rejection

- a) Any emergency exits do not have clear access, or identification signs and operating instructions, where required, are not clearly visible
- b) Equipment necessary to operate an exit, such as brake glass hammers, are not present
- c) The exit is broken, distorted or damaged in a way that stops it working properly
  - Note:** Some emergency exits are designed to be used only once. Do not operate them for testing purposes.
- d) Any controls for passenger access doors do not work properly
- e) Any warning device to indicate the operation or condition of the exit is not in working order



- f) Any interior body panel or fitting in a bus is not securely mounted or has exposed sharp edges due to damage, including corrosion or separated joints, that could injure a person who comes into contact with them
- g) Any floor covering is:
  - torn, worn or loose to an extent that it could trip passengers, or
  - not finished with a skid resistant surface.
- h) Any handgrip, handrail or hand-strap is loose or damaged
- i) Any passenger stop signal is inoperative
- j) Any step is damaged to an extent that it could trip or injure a person
- k) Seatbelts are not fitted (where applicable)
- l) Where fitted, any seatbelt is not functional
- m) Fire extinguisher is not filled, charged or under current inspection, if required
- n) Handle, nozzle or hose of a fire extinguisher is missing or damaged
- o) The extinguisher is not securely mounted in a readily accessible location in the vehicle in accordance with Australian Standard AS 2444 *Portable fire extinguishers – Selection and location*.

**Note:** Fire extinguishers can become ineffective even though they appear properly charged. For example powder type extinguishers subject to vibration can fail due to compacting of the powder.

Australian Standards AS 1851.1 *Portable fire extinguishers*, contains suitable procedures for inspecting and testing fire extinguishers.

AS 2444 *Portable fire extinguishers – Selection and location* outlines the appropriate type, size and location of fire extinguishers for vehicles.

**Table 13.1** Fire Extinguisher requirements in accordance with AS 2444

Type of vehicle	Minimum rating and classification of extinguishers	Minimum number of extinguishers
<b>Passenger-carrying vehicle</b>		
In urban areas or on short trips outside urban areas	2A:20B (fitted with hose)	1
Outside urban areas or when fitted with integral luggage compartment	2A:20B (fitted with hose)	2 (one to be mounted near the under-floor area or engine)

**Note:** Consideration should be given to all extinguishers having an E rating where electrical hazards may be found in vehicles, if capable of being connected to 240V a.c., e.g. caravans, campervans and the like.

- p) The extinguisher does not have the Standards Australia approval marking, having a fire test rating (as defined in the standard) of at least 20B and fitted with a hose.

### 13.2 Check school bus warning system

A school bus is a bus used solely or principally for the conveyance of children to or from school.

For any bus that is fitted with lights and signs indicating that it is a school bus, the following reasons for rejection apply.

Not all state or territory road transport authorities apply the national requirements. Apply local requirement if different to national approach (e.g. New South Wales).

#### SCHOOL BUS WARNING SIGNS

**Reasons for rejection (Does not apply in New South Wales, Victoria or Tasmania - see local inspection manual for rejection reasons)**

Applies to buses fitted with warning lights after July 1999.

- a) A rectangular sign bearing either the words 'SCHOOL BUS' in black capital letters at least 100mm high or an image of two children in the same proportions as the children in Australian Standard AS 1743 *Road signs – Specifications*, image W6-3, with the image of the taller child at least 230mm high, is not displayed at the front and rear of the bus
- b) Either sign is not at least 550mm long and 400mm high if the warning lights are on the sign or 400mm long and 250mm high if the warning lights are not on the sign

- c) There are not two lights at each end of the bus
- d) If the lights are on the warning sign and obscure the words or image on the signs
- e) The signs do not have a black border and graphics or have a yellow surface complying with Class 1 or 2 of Australian/ New Zealand Standard AS/NZS 1906 *Retroreflective materials and devices for road traffic control purposes*
- f) The lights are not at least 300mm apart
- g) The lights are more than 100mm from the edge of the warning sign
- h) The lights are not on each side of, and the same distance from, the centre of the warning sign
- i) The lights are not at the same height and mounted as high as practicable
- j) The lights are mounted with the lowest point on the lens of each light at least midway between the highest and lowest points on the bus body
- k) Each light does not have an effective lit lens area of at least 60cm<sup>2</sup>
- l) If the centres of the warning lights are less than 1.8 metres above ground level no part of the warning lights or warning sign is to be on the left side of the bus
- m) If the warning lights, when switched on, do not emit a flashing yellow-coloured light and flash between 90 and 180 times per minute
- n) If the warning lights, when switched on, do not flash alternately at the same end of the bus
- o) If the warning lights, unless turned off, do not operate automatically when a door on the bus opens and for at least 10 seconds, and not more than 20 seconds, after all the doors on the bus have closed
- p) The bus does not have an audible or visible signal that tells the driver of the bus in the normal driving position when the warning lights are flashing
- q) The bus is not fitted with a switch that allows the driver of the bus to turn the warning lights off from the normal driving position
- r) Each light does not have a luminous intensity (in candela) of at least the values mentioned in Table 13.2 when measured at the angles mentioned in the table.

**Table 13.2** Luminous intensity values

Horizontal angle from centre of light									
	-30°	-20°	-10°	-5°	0°	5°	10°	20°	30°
10°				50	80	50			
50°		180	320	350	450	350	320	180	
0°	75	450	1000	1250	1500	1250	1000	450	75
-5°	40	270	450	570	600	570	450	270	40
-10°				75	75	75			

### 13.3 Check ordinary entrances and exits

#### Reasons for rejection

- a) No ordinary entrance door fitted on the left hand side
- b) Must not have an entrance or exit on the right side of the bus other than:
  - a mandatory emergency exit, or
  - the driver's door.
- c) The entrance door is:
  - less than 1800mm high, or
  - less than 550mm wide.
- d) A stairway on a double-deck bus:
  - is less than 400mm wide, or
  - has no guard rail or panel.

### 13.4 Check emergency exits

#### Reasons for rejection

- a) If the bus is not fitted with at least the number of emergency exits shown in Table 13.3.

**Table 13.3** Number of required emergency exits

Number of occupants, including the driver and standees, for each component deck or section	Minimum number of emergency exits
Less than 26	4
26–36	5
Greater than 36	6

- b) An emergency exit on at least three of the following surfaces:
  - roof front face
  - rear faceleft hand side
  - right hand sidefloor (top deck of a double-deck bus only).

- c) If an emergency exit is not fitted:
  - for a single deck bus—at the extreme rear of the bus or in the rear half of the roof of the passenger compartment
  - for a double-deck bus—at the front or rear face of each deck.
- d) If an emergency exit does not meet the minimum dimensions in Table 13.4

**Table 13.4** Emergency exit dimensions

Type of emergency exit	Dimension	Minimum
Emergency door	Height	1250mm
	Width	550mm
Emergency window	Area	0.4m <sup>2</sup>
	Height	500mm
	Width	600mm
Escape hatch	Area	0.4m <sup>2</sup>
	Height	500mm
	Width	600mm

- e) If there is no suitable means of opening any exit at all times
- f) An emergency exit is not capable of being operated from both the inside and outside of the vehicle
- g) Emergency hammers are not fitted for breakable glass exits
- h) The emergency exit is covered with a film and the vehicle no longer complies with, or cannot provide evidence of continued compliance with, ADR 44 or ADR 58 (as applicable)
- i) There is no 'EMERGENCY EXIT' sign displayed on the exit both inside and outside the bus

**Note:** Refer to *Vehicle Standards Guide 8 (VSG8)*, for more information about the requirements that apply to applying films (advertising, vandal proofing, tinting and other films) to bus emergency exits.

**Note:** A bus is not required to be fitted with an emergency exit if it:

- is designed and constructed to seat not more than 12 adults, including the driver, and
- is fitted with one or more doors on each side and these doors are fitted with an emergency release, and
- has an overall width of not more than 2 metres.

A hinged and latched door fitted to a small bus with a seating capacity of not more than 15 adults, including the driver, may be regarded as an emergency exit if it is capable of being opened outwards from inside the bus.

### 13.5 Check doors

Service doors that also function as emergency exits must meet the requirements in this section, as well as the requirements for emergency exits.

#### Reasons for rejection

If a bus is fitted with:

- a) An interior door that separates the space normally used by passengers from the access doors or emergency exits, or
- b) An inward opening door other than a 'jack-knife' or 'glide-away' door which is so constructed that no part of it extends beyond the back of the lowest step of the entrance or exit where it is located
- c) A forward opening (suicide) door.

### 13.6 Check steps

#### Reasons for rejection

- a) If any step within the vehicle is not securely fitted
- b) If the height of the tread of the lowest step from the ground is over 410mm or under 250mm
- c) The height of any step, in relation to an adjacent step is more than:
  - for an off-road (all-wheel drive) bus—450mm except a rear step that may be no more than 500mm
  - for a small bus having a single row of seats with an occupant capacity of 15 persons or less, including the driver—450mm
  - for any other bus—300mm.
- d) The transverse depth of the tread of each step in a small bus is less than 180mm
- e) The transverse depth of the tread of each step in a large bus is less than 225mm
- f) The width of the tread of the lowest step is less than the width of the entrance
- g) The width of each step, other than the lowest step, is less than 450mm
- h) If each step is not fitted with skid-resistant tread
- i) If step treads and risers are not directly illuminated, except in the case of an external access step to a single row of seats for a small bus having a seating capacity of not more than 15 adults, including the driver.

### 13.7 Check interior height

#### Reasons for rejection

- a) For a bus with a longitudinal aisle the measurement from the floor to the centreline of its roof is less than:
  - for a small bus with an aisle length not over 2 metres—1.2 metres
  - any other small bus—1.35 metres
  - for each deck of a double-deck bus—1.65 metres
  - for a large bus that is not involved in frequent stops for the purpose of picking up or setting down passengers—1.65 metres
  - for a large bus that is involved in frequent stops for the purpose of picking up or setting down passengers—1.8 metres.
- b) For a bus without a longitudinal aisle the measurement from the floor to the centreline of its roof is less than:
  - for a large bus—1.5 metres
  - for another bus—1.2 metres.

### 13.8 Check aisle width

#### Reasons for rejection

- a) If the width of an aisle is less than:
  - for a small bus—300mm
  - for a large bus used only to carry seated passengers—300mm
  - for another large bus—380mm.

### 13.9 Check passenger seating

#### Reasons for rejection

- a) Any passenger seating position does not have a dimension of at least 400mm when measured along the front of the seat cushion
- b) The distance from the foremost point of each seat squab to the foremost point of its corresponding seat cushion is less than 350mm
- c) There is any obstruction horizontally forward of the seat squab for a distance, when measured on the centreline of the seating position and between the top of the seat cushion and any point up to 610mm above the floor, within:
  - in the case of opposite facing seating positions (as shown in Figure 13.1)—1200mm, or
  - in the case of other seating positions (as shown in Figure 13.2)—660mm.

Figure 13.1 Measuring obstructions for opposite facing seat

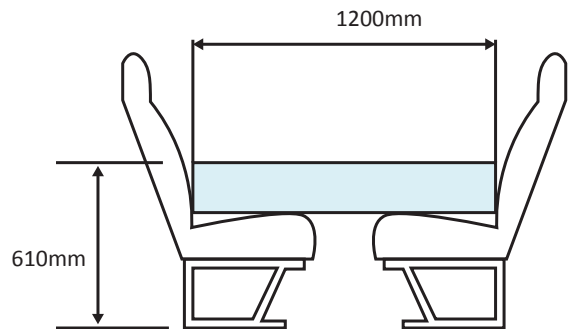
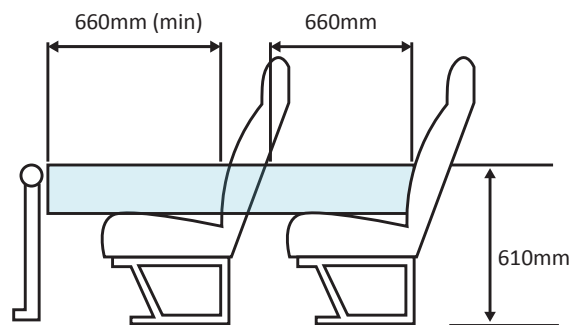

Figure 13.2 Measuring obstructions for non-opposite facing seats



- d) There is any obstruction in front of each seating position for a space 200mm horizontally forward of the seat cushion, and 300mm in width but not extending beyond the nominal seat width, and between the floor and the level of the seat cushion

**Note:** The spaces described by this requirement shall not intersect each other or any other spaces designated for standing passengers or required minimum aisle width.

- e) The average height of each unloaded seat cushion relative to the floor exceeds 500mm or is less than:
  - for a large bus—400mm
  - other buses—380mm
  - if the floor level is interrupted by a wheel housing and/or engine housing or similar structure—300mm.
- f) Any seat interrupts the minimum access and clearance dimensions
- g) Any seat is not securely attached to the vehicle
- h) The minimum concave radius of any seat squab is less than 450mm for a route service omnibus or 300mm for any other omnibus, when measured in any horizontal plane between the top of the seat cushion and 610mm above the floor and within 150mm on either side of the centreline of the seating position



- i) Where luggage racks are fitted above any seating position, the distance between the lowest part of the rack and the top of the seat cushion is less than 950mm on the centreline of the seat.

### 13.10 Check driver seating

#### Reasons for rejection

- a) If the driver's seat on a bus is not:
- securely attached to the bus, and
  - designed and fitted in such a way that the driver can have control of the bus.

### 13.11 Safety and guard rails

#### Reasons for rejection

- a) A bus is not fitted with a suitable rail or partition in front of any seat located on the left side of the bus immediately behind a step so as to prevent persons from falling into a step well
- b) A bus with a centre or rear door, suitable rails and/or partitions are not in place to stop passengers coming into contact with the rear face of the opening door
- c) The driving position on a large bus is not separated from the passenger compartment with either a suitable guard rail or other structure so as to inhibit passengers from:
- coming into contact with the driver or the controls, or
  - obstructing the drivers view.

### 13.12 Engine and fuel system

#### Reasons for rejection

- a) Where the transmission incorporates any longitudinal drive shafts, couplings, or intermediate shafts, there is no guard that prevents the front end of any such shaft or coupling contacting the road in the event of detachment of the front end from its normal position
- b) Fuel tank or components are located:
- in the passenger, engine or driver compartment
  - less than 1.2 metres from the front of the bus, or
  - outside the overall width of the bodywork.

**Note:** A fuel tank is considered to be separated from the engine compartment if it is separated by a chassis rail or by a fuel resistant partition.

A filler pipe, including the filler inlet, is considered to be separated from the engine compartment if it is separated by:

- a fuel resistant partition; or

- by a distance not less than 900 mm, so that they are not exposed to excessive heat and that in the event of any fuel spillage during filling operations or leaks from the filler cap connection, fuel cannot fall on to the engine or exhaust system.

- c) The fuel tank filler inlet:
- allows accumulation of overflow or leakage
  - projects beyond the overall width of the body
  - is less than 900mm from an access opening or emergency exit, except in the case of a small bus having an occupant capacity of up to 15 persons, including the driver
  - is not beneath an access opening or emergency exit, except in the case of a small bus having an occupant capacity of up to 15 persons, including the driver
  - is located in the interior of the bus unless protected by a sealed cover that does not allow leakage, or
  - is located in the engine compartment.
- d) The engine compartment:
- contains insulating materials that could be or are contaminated with oil or fuel
  - does not have drainage holes for fluids
  - does not have heat-resisting material on surfaces adjoining the rest of the bus.
- e) The fuel system including lines and fittings:
- are located such that leaks would contact the exhaust and no shield is provided, or
  - provides for gravity feed to the engine.



## Section 14

# Trailers

### Objective:

To ensure that all components and associated systems are in a serviceable condition and meet all legislative requirements.

### Australian Design Rules relevant to this section:

- ADR 1 Reversing lamps**
- ADR 6 Direction indicators**
- ADR 38 Trailer brake systems**
- ADR 42 General safety requirements**
- ADR 43 Vehicle configuration and dimensions**
- ADR 44 Specific purpose vehicle requirements**
- ADR 45 Lighting and light-signalling devices not covered by ECE regulations**
- ADR 47 Retroreflectors**
- ADR 48 Devices for illumination of rear registration plates**
- ADR 49 Front and rear position (side) lamps, stop lamps and end-outline marker lamps**
- ADR 62 Mechanical connections between vehicles**
- ADR 63 Trailers designed for use in road trains**

### 14.1 Check brake components

#### Reasons for rejection

- a) Abrasions or cuts on brake hoses penetrate further than the outer protective covering
- b) Brake pipes, hoses and connections are not securely mounted, are cracked, broken, kinked, crimped, damaged by heat or have visible signs of leakage, swelling or bulging
- c) Brake control mountings, pivots, cables or links are missing, frayed, kinked, loose, broken, excessively worn or binding
- d) Brake drums or discs are not fitted, or have missing pieces, or cracks other than short heat cracks inside the drums
- e) Drums or discs are worn beyond the manufacturer's specification

- f) Any caliper, wheel cylinder or master cylinder leaks
- g) Friction material of the linings or pads are contaminated with oil, grease, brake fluid or another substance that will reduce the friction coefficient of the friction material
- h) The thickness of the linings or pads is less than the manufacturer's recommended minimum. If this is not known or is no longer appropriate, the thickness of the linings or pads is less than the following:
  - the rivet or bolt head on riveted or bolted linings, or
  - within 3mm of the friction material mounting surface on bonded pads or linings.
- i) Brake chambers (including chamber clamps) or camshaft support brackets are loose, bent, cracked or missing
- j) Brake linings or pads are missing, broken or loose on their shoes or plates. Brake components such as springs, anchor pins, cam rollers or bushes, pull or push rods, clevis pins, retainers or brake chamber mounting bolts are missing, loose, damaged or broken
- k) The brake controls of the towing unit do not cause the corresponding trailer brake to work when they are operated
- l) There are any air/vacuum or hydraulic leaks
- m) Where the trailer is fitted with air/vacuum brakes it does not have at least one reservoir
- n) Any reservoir or tank for vacuum or air storage is not protected by a check valve with manual function
- o) Reservoirs are not secured or their mountings are deteriorated
- p) Air reservoir drain valves on reservoirs do not work properly cannot be readily operated by the driver/operator or the valve is not fitted at the lowest point of the reservoir
- q) With any brake fully applied, any stroke indicator displays evidence of excessive stroke (known as over-stroking).

**Note:** Not all automatic slack adjusters which travel past 90 degrees are considered over-stroked.

Further information on slack adjusters can be sought from the brake component manufacturers or industry advisory documents.

Figure 14.1 Example of excessive stroke (over-stroking)

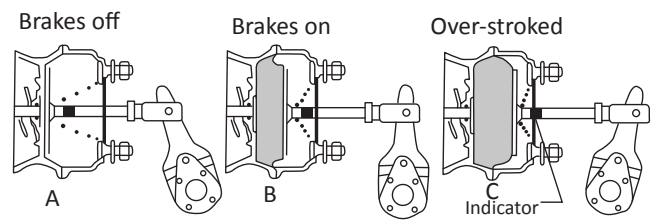

- r) Brake chamber push rods or pull rods move more than 80% of their maximum stroke or travel over centre with the brakes fully applied

**Note:** The push or pull rod may travel further on long stroke brake chambers.

Further information on long stroke brake chambers can be sought from the brake component manufacturers or industry advisory documents.

- s) Brake adjusters are not properly adjusted, are bent, damaged or excessively worn
- t) The truck/trailer interconnecting flexible hose and coupling is not properly mated or secured
- u) Any wiring for electric brakes is frayed, bared or not secure
- v) Any handle of a parking/hand brake fitted to a trailer that is not fitted with a locking device capable of holding in any position
- w) Brake components are mismatched on the same axle i.e. booster size and volume.

## 14.2 Check trailer brakes and breakaway protection

The examiner should seek the assistance of another person in order to make a thorough check of the breakaway protection systems.

### Reasons for rejection

- a) For trailers with a gross trailer mass (GTM) in excess of two tonnes, the trailer brakes do not operate immediately when the trailer is disconnected from the towing vehicle and do not remain fully applied for at least 15 minutes
- b) A trailer's service brakes do not apply automatically when any trailer service hose coupling or connection is disconnected or the operating pressure falls below the recommended operating level
- c) A truck trailer interconnecting flexible hose and coupling is not properly mated or secured
- d) For trailers with a GTM in excess of two tonnes, the trailer brakes are not capable of being applied and released from the normal driving position.

### 14.3 Advanced Braking Systems

This section covers trailers which have advanced braking systems such as anti-lock braking systems (ABS), electronic braking systems (EBS), electronic stability control (ESC), etc.

#### Reasons for rejection

- a) An advanced braking system warning lamp:
  - indicates a fault with the trailer's system
- b) An advanced braking system component (wheel speed sensor, etc) is missing or damaged to an extent where it does not perform its intended function.
- c) Advanced braking system wiring or connectors are corroded, damaged, not insulated or are not securely fastened.
- d) Electrical wiring is located where it can:
  - become exposed to excessive heat
  - come into contact with moving parts.
- e) An advanced braking system component or system has been modified outside of manufacturer's specifications.
- f) A trailer, fitted with an advanced braking system, which has the capability of having another trailer coupled behind (i.e lead trailer in a b-double) is not fitted with a ABS/EBS connector which allows to attach an ABS/EBS equipped rear trailer.

### 14.4 Check drawbar

#### Reasons for rejection

- a) Drawbar is extensively corroded, cracked, bent or insecurely mounted
- b) Where any part of the drawbar is removable the bolts, studs, nuts etc. fastening those parts do not have a locking device such as a U-clip, split pin, spring washer or nylon lock nut
- c) There is more than 6mm of free movement between the sub-frame and hinged drawbar at the attachment point (compression of any flexible bush is to be excluded)
- d) Drawbar eye is elongated by wear, cracked or worn more than 5% of the original diameter
- e) Drawbar eye bush is worn through, insecure or is attached by welding (unless manufacturer specifies welding)
- f) Drawbar eye/block has been welded contrary to manufacturer's specification or recognised welding guidelines
- g) Where ADR 62 applies, the drawbar eye does not display the manufacturer's name/trademark and the rating

- h) Any mounting bolts, fasteners or weld beads have advanced corrosion
- i) Any sliding drawbar latching mechanism is inoperative
- j) One or more stops on a sliding drawbar are missing or are inoperative
- k) A sliding drawbar has more than 6mm of movement between the slider and the housing
- l) Air or hydraulic cylinders, hoses or chambers on sliders leak (other than normal weeping of hydraulic seals).

### 14.5 Check towing attachments

#### Reasons for rejection

- a) Any towing attachment, mounting bolts, fasteners or weld beads are loose, cracked, broken or extensively corroded
- b) Any ball coupling locking device is broken or inoperative.
- c) For a trailer designed for use in a road train, the rear coupling overhang exceeds:
  - For a semitrailer, 30% of the distance from the point of articulation at the front of the trailer to the centre of the rear axle group; or
  - For another type of trailer, 30% of the distance from the centre of the front axle group to the centre of the rear axle group.

**Note:** 'Rear coupling overhang' is the distance from the centre of the rearmost axle group to the pivot point of the coupling near the rear of the vehicle.

### 14.6 Check skid plates

#### Reasons for rejection

- a) Any mounting bolts, fasteners or weld beads have advanced corrosion
- b) Skid plate is cracked or has missing or loose bolts
- c) Skid plate flatness is outside the limits of Australian/ New Zealand Standard AS/NZS 4968.3 Heavy road vehicles – Mechanical coupling between articulated vehicle combinations:
  - is bowed downwards (convex) by more than fifth wheel designated effective diameter (mm) divided by 150
  - is bowed upwards (concave) by more than fifth wheel designated effective diameter (mm) divided by 300
  - bowing exceeds limits shown in Figure 14.2.
- d) A Wedge block fitted to a trailer for use with a ballrace type coupling is excessively worn, cracked or attachment bolts are missing



Figure 14.2 Skid plate flatness limits

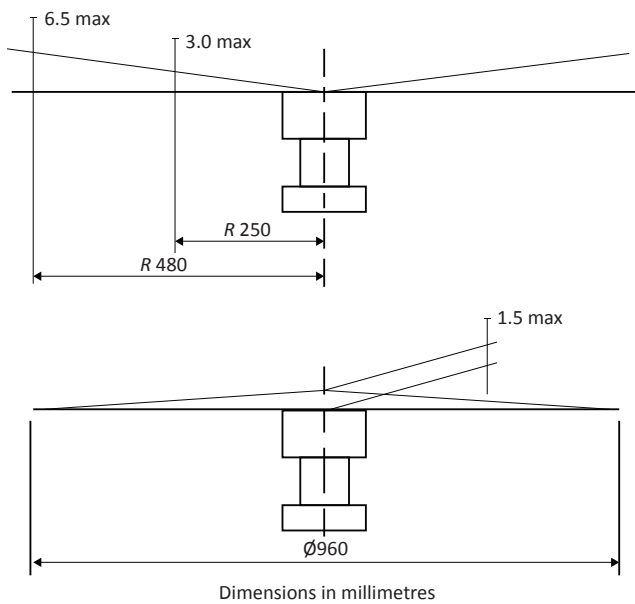

**Note:** The above diagram has been extracted from AS/NZS 4968.3:2011. The dimension of 960 mm is indicative only and is not the design size of the skid plate.

- e) Skid plate is worn more than 20% or 2mm whichever is the lesser.

## 14.7 Check kingpin

### Reasons for rejection

- The kingpin does not display the manufacturer's name/trademark, nominal size in millimetres (e.g. 50mm) and the 'D-value' rating in kilonewtons (kN)
- For trailers used in a road train, the kingpin is not rated to at least 162kN
- The vertical or horizontal movement between the upper and lower fifth wheel halves of coupled vehicles exceeds 13mm
- The kingpin is worn or loose
- Any mounting bolts, fasteners or weld beads have advanced corrosion
- An adaptor is used to fit a kingpin to a fifth wheel coupling
- Kingpin has missing or loose bolts
- Any welding performed to the kingpin not carried out in accordance with the requirements of Australian Standard AS 2175
- A Wedge block which forms part of the kingpin for use with a ballrace type coupling is excessively worn, cracked or attachment bolts are missing
- The maximum wear limits for kingpins is exceeded.

Table 14.1 Kingpin maximum wear limits

Size (mm)	F (mm)	G (mm)	H (mm)
50	49	71	73
75	73	100	73.3
90	86	112	62

**Note:** Dimensions F, G and H are illustrated in Figure 14.3.

Figure 14.3 Kingpin wear dimensions

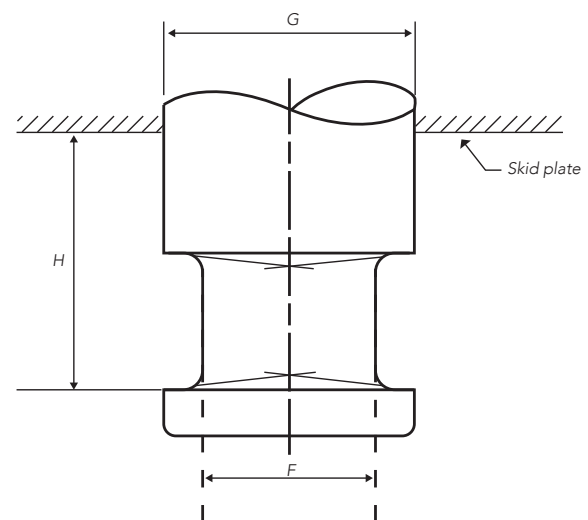

**Note:** The above table and diagram has been extracted from AS/NZS 4968.3:2011.

## 14.8 Check safety chains, cables and brake connections

### Reasons for rejection

- Safety chains, cables or brake connections are stretched, nicked, frayed, worn, cracked or extensively corroded
- Any safety chain that has insecure attachment points, clamps or fasteners, and is liable to accidentally disconnect or is not readily detachable from the towing vehicle
- Safety chains attachment on a trailer exceeding 3500kg ATM involves welding or deformation of the chain
- Safety chain retaining brackets are cracked, deformed or not secure
- Safety chain retaining brackets do not meet the requirements of ADR 62 (where applicable).

**Note:** Safety chains should be inspected in accordance with the Australian Standards: AS 1872, AS 2321, AS 4177.4 as in force at the time the vehicle was manufactured.

For information on safety chains and the dimensions and configurations of typical chain retention brackets, refer to Additional Information – Safety Chains.

## 14.9 Check suspension components

### Reasons for rejection

- a) U-bolts or other spring to axle or spring pack clamp bolts, centre bolts, spring eyes or hangers, torque, radius or tracking component assemblies, control arms, bushes or any parts used to attach them to the vehicle frame or axle are cracked, loose, broken, missing or worn beyond manufacturer's limits
- b) Nuts do not fully engage U-bolts
- c) Any suspension component is not correctly aligned or is damaged, loose or broken
- d) Any nut, bolt or locking mechanism is insecure or missing
- e) Springs are cracked, missing or broken

**Note:** Superficial crazing is acceptable. This is often present on rubber suspension components even when new.

- f) Air bags leak or sag
- g) Leaves in a leaf spring are displaced sideways more than 10% of their width or so that they contact wheels, brakes or the frame
- h) Any walking beam type heavy vehicle suspension has signs of damage to beam
- i) Shock absorbers, if originally fitted, are missing, loose, inoperative or leak

**Note:** Shock absorber misting is not considered leaking. For further information refer to Section 4 – Steering and Suspension, Additional Information – Shock Absorber Leakage and Misting.

- j) Shock absorber mountings or bushes are not secure or damaged.

**Note:** Repairs using either heating or welding may adversely affect the strength of suspension components. Any such repairs should only be affected in consultation with the vehicle or component manufacturer.

## 14.10 Check sliding axles

### Reasons for rejection

- a) Sliding axles do not lock securely in position or have lock pins missing or not engaging
- b) Secondary securing devices and locking indicators do not work properly
- c) Lock pins are excessively worn, cracked or damaged.

## 14.11 Check wheels/rims

### Reasons for rejection

- a) Any wheel or rim:
  - is loose
  - is cracked
  - is buckled
  - has pieces of casting missing
  - has elongated stud holes
  - has weld repairs not in accordance with relevant industry practice.
- b) Any wheel contacts unrelated vehicle components at any point through its full range of travel
- c) Spiders have cracks across a spoke, hub or area
- d) Wheels are not compatible with hubs
- e) Required valve protection lugs are missing
- f) Wheels fail to rotate freely
- g) Hubs seals leaking
- h) Excessive end-play in hubs.

## 14.12 Check wheel fasteners

### Reasons for rejection

- a) Wheel nuts and bolts do not have a thread engagement length at least equal to the thread diameter, except where specified by the vehicle manufacturer or the fitting of the wheel nut does not match the taper of the wheel stud hole
- b) Any hub has missing, cracked, stripped or broken wheel mounting nuts, studs or bolts
- c) Fasteners are not the correct type for the wheel being used or allow a rim to slip on its spider
- d) Spacer plates are used between hub and wheels, except where fitted by the vehicle manufacturer
- e) Any item that is fitted to the tyre/rim/wheel (other than tyre pressure monitoring or inflation) which is not technically essential to the vehicle, protrudes from any part of the vehicle so that it is likely to increase the risk of bodily injury to any person
- f) Any item that is fitted to the tyre/rim/wheel which is technically essential to the vehicle, is not designed, constructed and affixed to the vehicle in a way that does not minimise the risk of bodily injury to any person.

### 14.13 Check retaining rings

#### Reason for rejection

- a) Lock or side rings are incorrectly seated, sprung, mismatched, bent, broken or cracked.

### 14.14 Check tyres

#### Reasons for rejection

- a) A tyre does not have at least 1.5mm tread depth in the principal groove, in a continuous band which runs around the whole circumference of the tyre and extends across at least 75% of the width of the tyre

**Note:** Tread wear indicators are built into the principal groove of most tyres to indicate when tread depth reaches about 1.5mm. The depth of the tyre tread above these indicators is not included in the assessment of tread depth around the circumference of a tyre.

*In effect, these requirements allow a tyre to be worn to less than 1.5mm tread depth on its edges, provided that at least 75% of the remaining width of the tyre has a minimum tread depth of 1.5mm around the whole circumference.*

- b) The overall diameter of dual tyres on the same side of an axle is not matched within 25mm
- c) A tyre (including sidewalls) has deep cuts, chunking, bumps, bulges, exposed cords or other signs of carcass failure
- d) A tyre has been re-grooved (except where indicated on the side wall that the tyre is suitable for re-grooving)
- e) When in the straight ahead position, the tyres of a vehicle project beyond the extreme width of the mudguards
- f) Any tyre is not of a type constructed for unrestricted road use
- g) Any retreaded or remoulded tyre is not marked with the words "RETREAD" or "REMOULD" and where speed limited the words "MAX. SPEED XX KM/H" or "SPEED LIMITED TO XX KM/H" ("XX" means the maximum speed i.e. 125kph)
- h) The speed rating of all tyres is not of at least 100 km/h or the vehicle's top speed, whichever is the lesser, unless a lower rating has been specified by the manufacturer
- i) A tyre fitted to a heavy vehicle is not suitable for road use if:
  - the tyre load ratings are less than the minimum ratings specified originally by the vehicle manufacturer
  - tyres are not compatible with the rim to which they are fitted
  - dual tyres contact each other

- the tyres or wheels on a vehicle contact the body, chassis, frame or braking or suspension components.

### 14.15 Check exterior body panels and fittings

#### Reasons for rejection

- a) Exterior body work including mudguards on a vehicle have exposed sharp edges (including corrosion or accident damage) that could injure a person who comes into contact with the vehicle
- b) Mudguards are not properly fitted to provide protection over the full width of the wheels and tyre(s) and any mudguard does not extend inboard over the full width of the tyre/s (except where part of the body of the vehicle acts as a mudguard)
- c) The bottom edge of the mudguard and/or mudflap at the rear of any vehicle is higher off the ground than 37% of the horizontal distance between the centre of the axle and the mudguard

**Note:** The height of the mudguard and/or mudflap from the ground need not be less than 230mm or for a vehicle built to be used off-road 300mm.

- d) Any motor vehicle which is 2.2 metres or more in width and fitted with a body which is less than 300mm in height at the rear, measured from the lowest point of the body above the ground to the highest point, does not have the rear face of any rear mudguards silver or white in colour

**Note:** Reasons for rejection (d) does not apply when a vehicle is correctly fitted with rear marking plates or conspicuity markings.

- e) Any after-market fittings attached to the exterior of the trailer that could cause injury to a person coming into contact with that part of the trailer.

**Note:** For information on mudguard or mudflap requirements, refer to Additional Information – Mudguard and Mudflap Requirements.

### 14.16 Check rear marking plates

#### Reasons for rejection

- a) Retroreflective rear marking plates or conspicuity markings are not fitted to a trailer with a GTM greater than 10 tonnes
- b) Rear marking plates or conspicuity markings are not fitted in locations specified by VSB12
- c) Rear marking plates or conspicuity markings are faded, damaged or incorrectly fitted.

**Note:** For more detailed information on rear marking plates refer to Vehicle Standards Bulletin 12 (VSB12) National Code of Practice: Rear Marking Plates. A copy of VSB12 may be obtained from the NHVR website at [www.nhvr.gov.au/vehiclestandards](http://www.nhvr.gov.au/vehiclestandards)

### 14.17 Check number plate

#### Reasons for rejection

- a) The number plate is obscured, for example, by a towing attachment, goose neck or tow ball
- b) Number plate covers are tinted, reflective, rounded or bubble like
- c) The number plate is not issued or approved by the state or territory road transport authority
- d) The number plate is damaged or faded to the extent that the registration number is not legible from a distance of 20 metres
- e) The number plate is fitted to a hinged plate that enables the plate to hinge whilst the vehicle is in motion
- f) The number plate is not substantially parallel to the vehicle's axles
- g) The number plate is mounted more than 1300mm from the ground

**Note:** State or territory road transport authorities may allow a number plate to be attached more than 1300mm from the ground if the design of the vehicle does not allow it to be installed at the required height. For more information about this requirement, contact the state or territory road transport authority.

- h) Characters on the number plate are not clearly visible from a distance of 20 metres at any point within an arc of 45 degrees from the surface of the number plate above or to either side of the vehicle
- i) The number plate is positioned so that it is not illuminated by at least one number plate light.

### 14.18 Check electrical equipment

#### Reasons for rejection

- a) Any electrical wiring or connector is:
  - corroded
  - damaged
  - not insulated or securely fastened so that it could be damaged.
- b) Electrical wiring is located where it can:
  - come into contact with combustible substances
  - become exposed to excessive heat
  - come into contact with moving parts.

### 14.19 Check chassis

**Note:** Refer to Additional Information – Rust and Corrosion for a detailed explanation of checking for rust.

#### Reasons for rejection

- a) Any part of the chassis or sub-frame is weakened or failure of a component is likely to occur from being:
  - cracked
  - distorted
  - sagging
  - broken
  - loose
  - affected by extensive or advanced rust.
- b) Any fastenings between frame members, including welds, are loose, distorted or cracked
- c) Any chassis or sub-frame repairs on the vehicle that have not been carried out in accordance with recognised industry repair methods and standards
- d) Frame members in load areas are missing or damaged to an extent that the load area is not properly supported or the members are likely to fall out or contact moving parts
- e) Trailer chassis has been altered without certification of compliance with Section H of VSB6.

**Note:** For further information, refer to Appendix B – Vehicle Modifications.

### 14.20 Check lights and reflectors

#### Reasons for rejection

- a) Compulsory reflectors are damaged, obscured, deteriorated, not installed in the correct location or are not fitted
- b) Any of the following lights are inoperative, obscured, deteriorated, insecure or not fitted where required or are an incorrect colour:
  - tail lights (red)
  - brake lights (red)
  - reversing lights (where fitted) (white)
  - turn signal indicator lights (yellow)
  - clearance/end outline marker lights (white/yellow to front, red to rear)
  - number plate light (white)
  - side marker lights (yellow to front, red to rear).
- c) Any reflector on the vehicle, other than conspicuity markings:
  - show white to the side or rear
  - show red to the side or front

**Note:** The rearmost side reflector can be red if it is grouped with the rear position lamp, the rear end-outline marker light, the rear fog light, the stop light, the red rearmost side-marker light or the rear retro-reflector.

- show yellow to the front or rear
- show a colour other than red, yellow or white.



- d) Any rear light other than a reversing light is damaged to the extent that white light shows to the rear of the vehicle
- e) Any yellow clearance light, side marker light or turn signal indicator is damaged so that it shows white light
- f) The number plate light is not directing light onto the surface of the rear number plate
- g) Any light has a tinted cover over it that affects its intended operation
- h) Any light not clearly visible under normal conditions and of a consistent intensity, or affected by dirty lenses or poor electrical contact
- i) Lenses and light reflectors are not securely mounted, are faded or discoloured and are not free from cracks, holes, or other damage which would allow the entry of moisture or dirt to impair the efficiency of the light or reflector
- j) Lighting does not comply with the *Heavy Vehicle (Vehicle Standards) National Regulation*
- k) For an LED type light, more than 30% of the individual LEDs do not function.

**Note:** For example, if an LED light bar is made up of 10 LEDs, at least 7 of the LEDs must be working. If only 6 LEDs work, this is grounds for rejection.

## Additional Information – Safety Chains

### Safety chains for trailers:

- in excess of 3.5 tonnes ATM
- trailers in excess of 2.5 tonnes GTM with fixed or rigid drawbars and automatic pin type couplings.

All fixed or rigid drawbar pig trailers (other than a converter dolly) and any other trailers without breakaway brakes, require safety chains to be fitted.

It is strongly recommended that all other trailers be fitted with safety chains, especially vehicles used in severe conditions, e.g. quarry vehicles which are jackknifed regularly for unloading.

Safety chains complement the safety features of the trailer's breakaway braking system, allowing the driver to maintain control of the truck and trailer combination following a coupling failure or disconnection.

Safety chains **MUST** be supplied and fitted to comply with the following requirements:

### Type of chain

Safety chains fitted to a trailer with an ATM over 3.5 tonnes, must be manufactured from alloy steel with a minimum breaking stress of 800MPa to conform with the mechanical properties of Grade T chain as specified in Australian Standard AS 2321 *Short-link chain for lifting purposes*.

### Required number and size of chains

#### Two separate chains must be used.

The minimum breaking strength or size of each chain used on the trailer must meet or exceed the values listed for the maximum gross trailer mass or aggregate trailer mass as indicated in Table 14.2.

Table 14.2 Safety chain size selection

#### Vehicles manufactured before 1 July 1998

Gross trailer mass (tonnes)	Chain size (millimetres)	Minimum chain breaking load (tonnes)
2.5–4.27	7.1	6.4
4.27–7.5	9.5	11.6
7.5–13.5	12.7	20.4
13.5–21.5	15.9	32.0
21.5–30.0	19.0	46.4
>30.0	22.0	63.2

### Vehicles manufactured from 1 July 1998 to 31 December 2008

Aggregate trailer mass (tonnes)	Chain size (millimetres)	Minimum chain breaking load (tonnes)
Over 3.5 and up to 4.3	7.1	6.4
Over 4.3 and up to 7.5	9.5	11.6
Over 7.5 and up to 13.5	12.7	20.4
Over 13.5 and up to 21.5	15.9	32.0
Over 21.5 and up to 30.0	19.0	46.4
Over 30.0	22.0	63.2

### Vehicles manufactured from 1 January 2009

Aggregate trailer mass (tonnes)	Chain size (millimetres)	Minimum chain breaking load (tonnes)
Over 3.5 and up to 5.0	6	5.1
Over 5.0 and up to 8.0	8	8.2
Over 8.0 and up to 12.5	10	12.8
Over 12.5 and up to 21.5	13	21.7
Over 21.5 and up to 32.5	16	32.8
Over 32.5	19	46.5

### Arrangement of chains

Safety chains must be arranged so that:

- the chains are attached to the trailer
- the chains are crossed to support the drawbar and prevent it from dropping to the ground in the event of coupling failure or disconnection
- the points of attachment to both the towing vehicle and the trailer must be as near as practicable to the coupling and arranged so as to maintain direction of the trailer in the event of coupling failure or disconnection.

**Ensure that the attachment fittings do not foul on the rear of the towing vehicle or trailer drawbar under any possible operating conditions.**

### Attachment of chains

Safety chains must be attached so that:

- the attachments to the towing vehicle and the trailer are capable of withstanding the specified breaking load of each chain
- the attachments to the towing vehicle and the trailer are separate from the coupling and its fasteners
- any safety chain attachment point affixing a safety chain to a drawbar must be located as near as practicable to the coupling. Where two points of attachment are required they must be mounted one on either side of the centreline of the drawbar
- the chain and coupling links are **NOT WELDED, DEFORMED OR ELECTROPLATED** subsequent to its manufacture.

Figure 14.4 “Berglok” coupling link

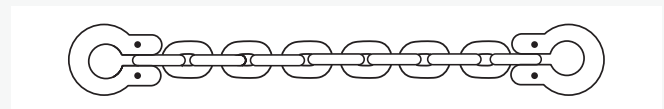

**Shackles are not permitted.**

**Ramshorn type hooks are not permitted.**

**Note:** Chain coupling attachment bracket and dimensional recommendations appear in Table 14.3.

### Chain attachment brackets

The dimensions and configurations of typical chain retention brackets are shown in the following table and diagram:

Table 14.3 Typical bracket dimensions

Minimum Chain (mm)	Minimum length of fillet weld	Bracket dimensions				
		Size length	(T1)	(T2)	(B)	(C)
9.5	6 x 200	16	16	4 x M12	19	*
12.7	6 x 360	20	20	4 x M16	25	*
15.9	8 x 420	25	20	4 x M20	32	*
19.0	10 x 480	25	25	4 x M20	38	*

\*Dimension ‘D’ to suit coupling link plus minimum clearance to prevent binding.

Figure 14.5 Typical attachment of chains

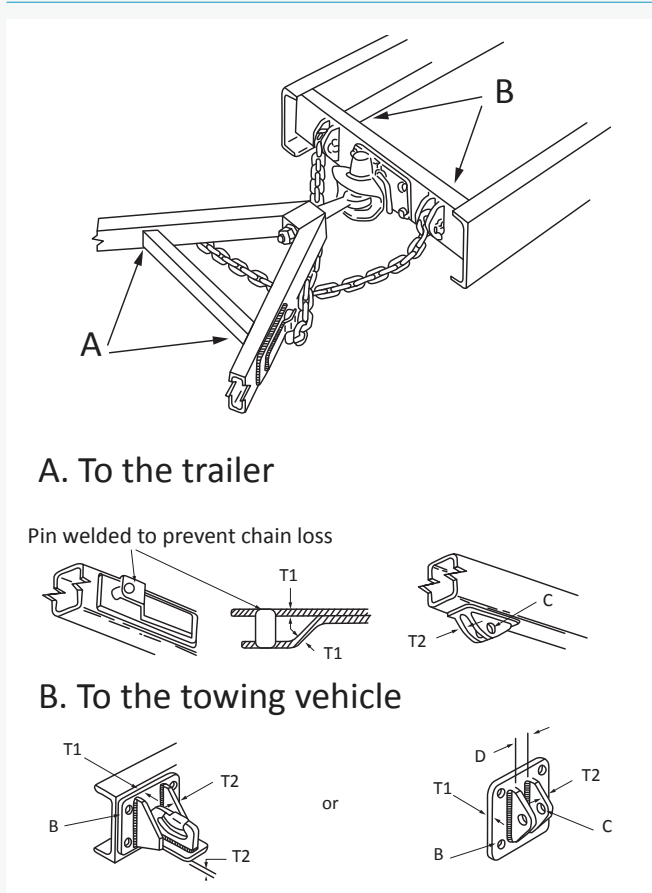

**Note:** Standard agricultural 3-point linkage pins are NOT suitable because they are manufactured from a lower grade of steel and will not meet the load requirements. It is acceptable to use a metric class 10.9 bolt of the correct diameter providing that the threaded portion of the bolt is clear of the brackets.

### Additional Information – Mudguard and Mudflap Requirements

Effective mudguards must be fitted for all wheels on all vehicles. However, this does not apply to a vehicle if the construction or use of the vehicle makes the fitting of mudguards unnecessary or impractical. Examples are:

- pole type trailers used to carry timber
- most road making plant
- some agricultural equipment.

Mudguards and mudflaps must be capable of deflecting downwards any mud, water, stones or any other substance thrown upward by the rotation of the wheels. As outlined in Figure 14.7, mudguards must be fitted to the vehicle in such a manner that provides continuous protection between a point in area A and a point in area B and must be provided for the overall tyre width of all tyres.

Notwithstanding the requirements specified above, the mudguard, including a mudflap (if fitted), does not need to come any lower than 230mm from the ground, or for an off-road vehicle, 300mm.

### Attachment pins

All pins used to connect safety chains to trailers and towing vehicles must be manufactured from steel bar with a minimum specification of 4140 or 4150 grade (Ultimate tensile strength – 1040MPa) unless otherwise approved.

Figure 14.6 Typical pin design

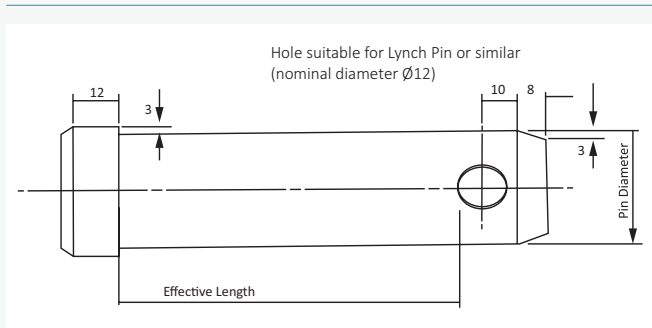

Material – Steel 4140 (Alternative 4150)  
 – Ultimate tensile strength – 1040MPa

Figure 14.7 Mudguard and mudflap protection area

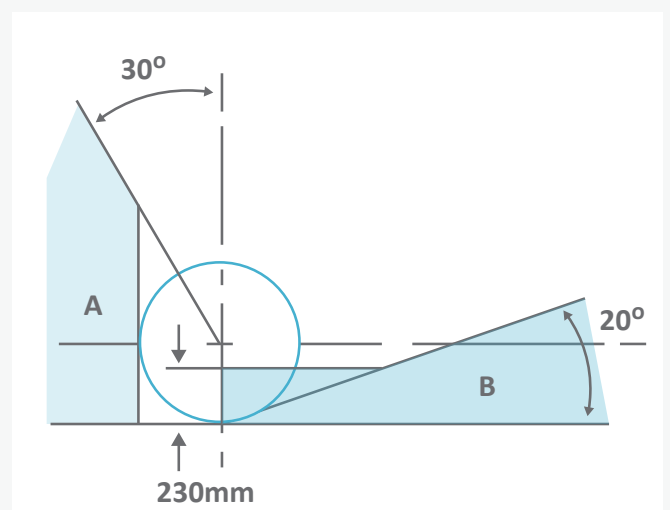

## Additional Information – Rust and Corrosion

### Classification of rust

The extent of corrosion in a trailer can range from light surface rust to the total breakdown of parent metal.

Depending on the individual trailer's design, there are many different ways in which corrosion can begin and the degree to which a material or structure is attacked can vary widely. In general, though, the formation of rust and resultant loss of metal occurs in areas which retain moisture because (for example) of a build-up of road dirt and mud.

In order to simplify identification and classification when carrying out a vehicle inspection, this publication classifies the extent of corrosion in three different stages.

#### Stage 1 - Surface rust

Light, powdery corrosion on the surface of a section of metal is termed surface rust and is sometimes the first indication of corrosion that can be observed; it should warn the owner of the trailer to take steps for preventing the rust from spreading. Surface rust can occur on or behind any body panel of a trailer particularly if the protective coating is scratched or damaged.

#### Stage 2 - Advanced rust

Surface rust, if left unattended, will develop into an advanced form of corrosion which can usually be seen as an eruption of oxidised metal, either on bare metal or under paint. This eruption occurs because the rust reaction involves an increase in volume so that pitting or bubbling of paint is the usual indication of penetration.

#### Stage 3 - Extensive rust

The final stage of the corrosion process is the formation of heavy encrustation of oxidised metal which completely replace the parent metal. This results in a hole or series of holes in the body panel or structural member of the trailer when the rust is removed. This category of rust can usually only be rectified by replacement of the affected body panels and parts.

### Classification of vehicle structures

Vehicle structural components can be categorised according to their importance to safety. For instance, sub-frames and other basic structural sections have to be absolutely free of rust because their failure could make a vehicle difficult to control and might cause it to crash. As already mentioned, such failures will also probably reduce the chances of survival in a crash.

### Primary structure

This category includes any structure or component which, if it collapsed, would make the vehicle uncontrollable or would considerably reduce safety in a crash. Examples of components in this category are shown in Figure 14.8.

#### Typical primary trailer structure components

1. Main structural members such as sub-frames and chassis rails
2. Suspension mountings and parts
3. Steering component mounting points (where applicable)
4. All floor panels.

Figure 14.8 Primary trailer structure components

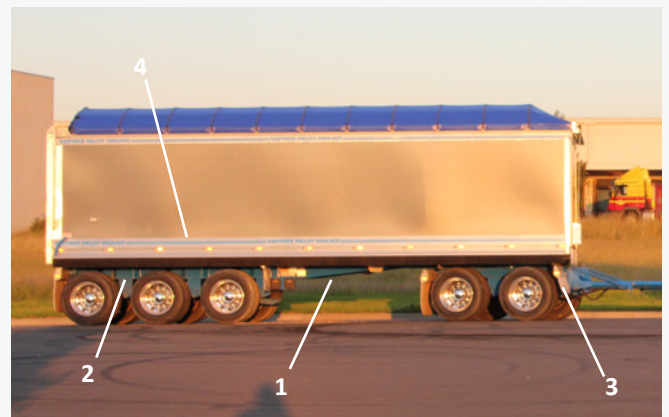

### Secondary structure

The second category includes any structure or component which, if it collapsed, would not immediately affect a vehicle's controllability or the protection provided by its built-in safety systems. Normally, surface rust or advanced rust would not be a cause for rejection in these components but extensive rust is usually either hazardous to persons in or near the vehicle because of its sharp edges. In such cases, extensive rust must therefore be rejected. Examples covered by this category are shown in Figure 14.9.

#### Typical secondary trailer structure components

1. Mudguards or fenders
2. Roof (where applicable).



Figure 14.9 Secondary trailer structure components



**Reasons for rejection**

The following table summarises the acceptability of rusted components in terms of the categories of rust and structures described so far. Remember that it is a general guide only and that in some cases it might be necessary to depart from the table.

Table 14.4 Acceptability of rusted components

Type of corrosion	Category of structure	
	Primary	Secondary
Surface rust	Acceptable	Acceptable
Advanced rust	Not acceptable	Acceptable (See Note A)
Extensive rust	Not acceptable	Not acceptable (See Note B)

**Note A:** Areas within 100mm of hinges and locks (e.g. bonnet and doors), are considered primary structures and must be free of advanced and extensive rust.

**Note B:** Extensive rust is not acceptable in secondary components, if it has resulted in hazardous conditions to persons in or near the vehicle e.g. sharp edges or loose panels.

**Inspection method**

Visual inspection is usually adequate since advanced corrosion is almost always associated with an eruption of oxidised metal and pitting or bubbling of paint.

However, this method may not be adequate in all cases. In under body areas prone to rust, such as steering and suspension mounting points and major structural components which include chassis, floor, structural sills and sub-frames presence of rust should be checked by probing with a rod. This method should also be used to check for presence of rust in other areas where cosmetic damage is not a problem, such as inside wheel arches.

In using this technique, great care must be taken to ensure that sound panels or paint work are not scratched or damaged in any way. It should be remembered that the purpose of such checks is to find out whether rust is present, not to determine its extent.

When checking for advanced rust, you should pay particular attention to seam welds and spot weld. These frequently corrode through from the interior and can result in the eventual detachment of panels. Any panel which is made insecure by such corrosion must be repaired even if it is an area of the component where rust holes are not an immediate danger.

**Repairs**

Surface rust on a component or structure is not immediately dangerous and is not a reason for rejection of a vehicle. However, if it is observed, the owner should be advised to have it rectified before it becomes serious. Rectification is simply a matter of completely removing the deposit and applying a rust-proofing coating or oil as is appropriate (body panels should be repainted using a good quality re-finishing system).

It should be noted that repairs made to primary trailer structure components solely by using body filling compounds are not acceptable. However, plastic filler or fibreglass can be used to smooth a non-structural component. A vehicle must not pass an inspection if it is found that a repair to a primary trailer structure component is carried out by methods which do not restore the original strength of the component or part. A good way to check for continuity of structure, if a fibreglass repair is suspected, is to run a magnet over the surface.

Extensive rust in structural members can only be repaired by replacing the affected member or by completely removing all rusted material and reinforcing it so that the original strength of the affected structural member is re-established.

Where a primary trailer structure is found to be in need of repair and the repaired component would normally be coated with a bituminous coating or covered by another vehicle component, it is quite in order to ask the owner to resubmit the repaired vehicle before the repairs are obscured so that the adequacy of the repairs can be assessed. A note to this effect should be made on the inspection report if this is required.





## Section 15

# Motorhomes, Caravans and Campervans

### Objective:

To ensure that motorhomes, caravans and campervans and associated components operate in a safe manner.

Australian Design Rules relevant to this section:

**ADR 42** General safety requirements

**ADR 43** Vehicle configuration and dimensions

**ADR 44** Specific purpose vehicle requirements

*Note: This section only provides for requirements that are specific to motorhomes, caravans and campervans. For general requirements for other components such as seatbelts, brakes etc. please refer to the relevant section.*

### 15.1 Visually inspect the living quarters

#### Reasons for rejection

- a) There are no permanently affixed sleeping berths
- b) There are no permanently affixed cooking facilities
- c) There is no table affixed

*Note: A table can be designed to be easily removed i.e. to convert the area to sleeping accommodation.*
- d) There are no storage facilities
- e) A motorhome or caravan manufactured after 1 July 1988 does not have at least one outward opening or sliding door on the left hand side or rear of the vehicle

*Note: Outward security doors fitted over bi-fold or inwards folding doors are not categorised as outward opening doors for this purpose.*

- f) There is no fire extinguisher fitted with a minimum rating of 5B and compliant with Australian Standard AS 2444 *Portable Fire Extinguishers*
- g) The fire extinguisher is not securely mounted in the living quarters or is higher than 1.2 metres from the floor
- h) A motorhome does not have at least one designated seating position for each sleeping berth
- i) A designated seating position that swivels in a motorhome is not capable of being securely locked into position for travelling
- j) Where gas appliances are fitted, there is no installation compliance certification for the vehicle supplied by a licensed gas installer

k) Where mains wiring is fitted, there is no electrical safety certificate showing compliance with Australian/New Zealand Standard AS/NZS 3001 *Electrical installations – Transportable structures and vehicles including their site supplies*

**Note:** Typically compliance certificates or labels can be found in the electrical switchbox, in the owner's manual or glovebox.

l) Where a toilet or urinal is present a catchment tank (black water tank) is not fitted or the tank is not vented directly to the atmosphere

m) Water tanks used for fresh, grey and black water are not securely mounted to the vehicle

n) A sink or shower drains:

- into a toilet pan or urinal or into any tank which a toilet pan or urinal empties, or
- into a tank that does not vent directly to the atmosphere.

o) At least half the number of windows are not capable of being opened unless the vehicle is provided with an alternative method of ventilation.

**Note:** If an alternative method of ventilation is required the following is considered acceptable:

- an inlet vent and at least two rotary vents, or
- a hatch in the roof towards the rear of the passenger compartment, or
- the vehicle is air-conditioned.



## Section 16

# Vehicle Dimensions

### Objective:

To ensure that vehicles do not exceed the legislative dimension requirements as prescribed in the *Heavy Vehicle (Mass, Dimension and Loading) National Regulation*.

Australian Design Rules relevant to this section:

**ADR 43** Vehicle configuration and dimensions

### 16.1 Width

#### Reason for rejection

- a) The width exceeds 2.5 metres.

**Note:** This is to be measured without taking into account any of the following:

- anti-skid devices mounted on wheels
- central tyre inflation systems
- side mounted lights and reflectors
- mirrors
- signalling devices
- tyre pressure gauges
- permanently fixed webbing assembly-type devices, such as curtain side devices, if the maximum width across the vehicle and including the devices, does not exceed 2.55 metres.

### 16.2 Height

#### Reasons for rejection

- a) The height of a double deck bus exceeds 4.4 metres
- b) The height of any of the following types of trailer exceeds 4.6 metres:
- a livestock carrier
  - a vehicle built with at least two decks for carrying vehicles
  - a specified semitrailer

**Note:** A livestock carrier is a vehicle that operates under a Notice issued under the Heavy Vehicle National Law which allows a heavy vehicle, that is higher than 4.3 metres but not higher than 4.6 metres and is built to carry prescribed livestock, to operate.

A specified semitrailer is a trailer with a maximum deck height of 1.2m (for at least half of the overall deck length), air suspension and is not a PBS trailer.

- c) The height of any other vehicle exceeds 4.3 metres.



## 16.3 Length

### Reasons for rejection

**Note:** This is to be measured without taking into account forward projecting blind spot mirrors.

#### Heavy motor vehicle

- The length of an articulated bus exceeds 18 metres
- The length of a non-articulated bus exceeds 14.5 metres
- The length of any other vehicle exceeds 12.5 metres.

#### Semitrailer and dog trailers

- The distance from the point of articulation to the rear overhang line exceeds:
  - for a refrigerated semitrailer not used in a road train or B-double combination— 9.9 metres; or
  - for another semitrailer or dog trailer—9.5 metres
- The distance from the point of articulation to the rear of a trailer exceeds:
  - for a refrigerated semitrailer not used in a road train or B-double combination—13.6 metres; or
  - for a semitrailer not used in a road train or B-double combination—13.2 metres; or
  - for another semitrailer or dog trailer—12.3 metres

Figure 16.1 Semitrailer

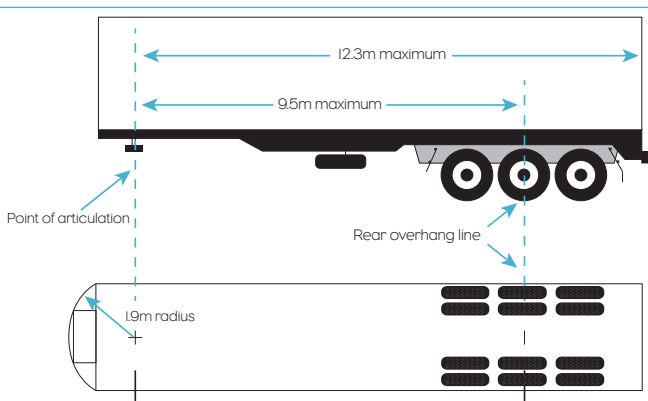
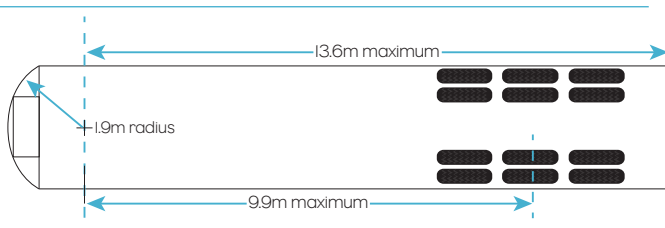

Figure 16.2 Refrigerated trailer



- For a semitrailer, if any part forward of the trailers front articulation point protrudes outside a 1.9 metre arc when measured from the front articulation point
- For a dog trailer or converter dolly, the drawbar exceeds 5.0 metres from the centre of the coupling to the front articulation point.

**Note:** The front articulation point for a dog trailer is the vertical axis of rotation of the front axle group, or single axle, of the trailer.

#### Pig trailers

- The drawbar exceeds 8.5 metres from the centre of the coupling to the rear overhang line.

#### Road train trailers

- For a trailer used in a road train, the drawbar is not at least 3.0m long from the centre of the coupling to the front articulation point.

## 16.4 Rear overhang

'Rear overhang' of a vehicle, means the distance between the rear overhang line and the rear of the vehicle, inclusive of any load.

### Rear overhang line

- For a vehicle with an axle group at the rear comprising only one axle, a line running along the centreline of the axle.
- For a vehicle with an axle group at the rear comprising two axles, one of which is fitted with twice the number of tyres as the other, a line running parallel to the axles that is:
  - closer to the axle carrying the greater number of tyres than it is to the other axle; and
  - located at one-third of the distance between the two axles.
- For a vehicle with any other axle group at the rear, a line running along the centre of the axle group.

**Note:** If an axle or axle group includes at least one steerable axle, steerable axles are to be disregarded except when all the axles are steerable.

### Reasons for rejection

#### Heavy motor vehicle

- The rear overhang exceeds either 60% of the distance from the front axle to the rear overhang line or 3.7 metres, whichever is the lesser.

Figure 16.3 Rigid truck

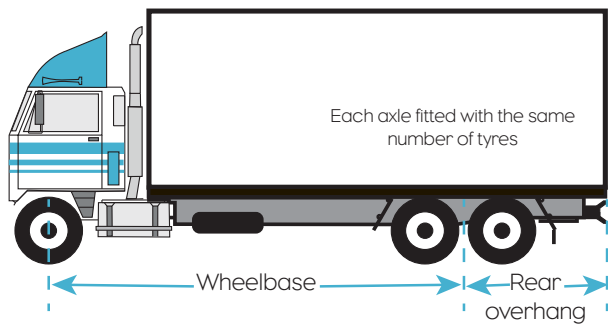

Dog trailer

- a) The rear overhang exceeds either 60% of the distance from the front articulation point to the rear overhang line or 3.7 metres, whichever is the lesser.

Figure 16.4 Dog trailer

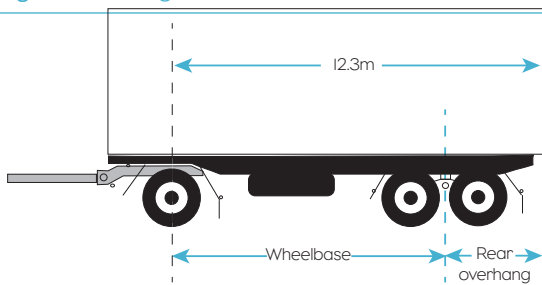

Pig trailer

- a) The rear overhang exceeds either the distance between the front of the trailers body or load carrying area and rear overhang line or 3.7 metres, whichever is the lesser.

Figure 16.5 Pig trailer

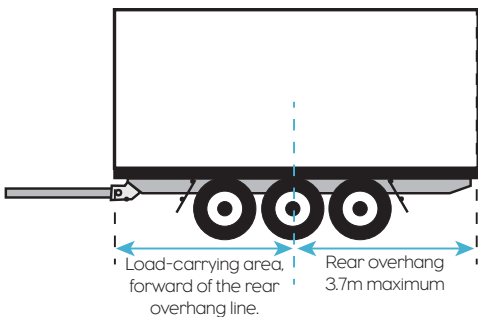

Semitrailer

- a) The rear overhang exceeds either 60% of the distance from the front articulation point to the rear overhang line or 3.7 metres, whichever is the lesser.

Figure 16.6 Semitrailer

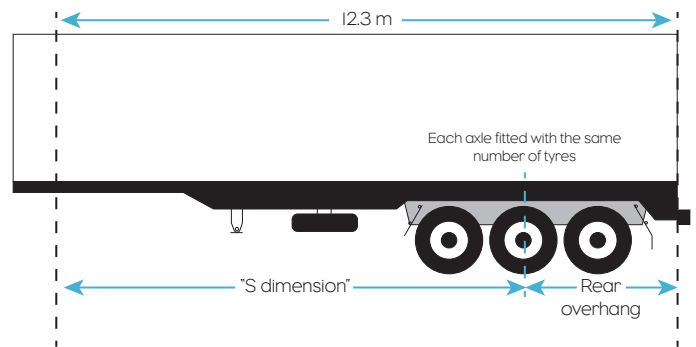



## Appendix A – Vehicle Category Codes and ADR Applicability Tables

The Australian Design Rules (ADRs) set out the minimum safety and environmental standards that heavy vehicles operating on public roads are required to comply with at the date of manufacture and during on-road operation. The ADRs have been developed for the purpose of:

- reducing the possibility of accidents occurring through such measures as improving lights and signals, drivers visibility and braking standards etc.
- mitigating the effects of those accidents that do occur, through such measures as seatbelts, energy absorbing steering columns, head restraints and occupant protection measures
- reducing the effects of motor vehicles on the environment by limiting the noise and pollutants emitted.

Many of the features associated with the ADRs are not readily apparent by visual inspection and evidence of a vehicles compliance with these requirements is demonstrated by the fitment of an identification (compliance) plate to the vehicle.

The ADRs are set out in two editions, being the second and third editions. The second edition ADRs cover vehicles manufactured between 1 January 1969 and the 30 June 1988. The third edition ADRs cover vehicles manufactured on or after 1 July 1988.

For the purpose of the ADRs vehicles are classified into various categories dependent on the type of vehicle. Each category is identified by two letters (e.g. NB- medium goods vehicle) and in some cases each category is further broken down using a number system following the letters (e.g. NB2 – over 4.5 tonnes GVM and up to 12 tonnes GVM). The ADRs apply to vehicles in accordance with the applicability dates set out at the beginning (usually in an applicability table) of each standard. The vehicle category codes are as follows:

### Vehicle category codes

Table A.1 Second edition ADR vehicle categories

Vehicle code	Vehicle category
OM	Omnibus
OM4	GVM over 4.5 tonnes
HG	Heavy Goods Vehicle, over 4.5 tonne GVM

Table A.2 Third edition ADR vehicle categories

Vehicle code	Vehicle category
MB	Forward Control Passenger Vehicle (up to 9 seats)
MC	Off-Road Passenger Vehicle (up to 9 seats with off road capabilities)
MD4	Light Omnibus (more than 9 seats) exceeding 4.5 tonnes GVM and up to 5.0 tonnes GVM
ME	Heavy Omnibus (more than 9 seats) exceeding 5.0 tonnes GVM
NB2	Medium Goods Vehicle exceeding 4.5 tonnes GVM and up to 12 tonnes GVM
NC	Heavy Goods Vehicle exceeding 12 tonnes GVM
TB	Light Trailer, GTM exceeding 0.75 tonne but not more than 3.5 tonnes
TC	Medium Trailer, GTM exceeding 3.5 tonnes up to 10 tonnes
TD	Heavy Trailer, GTM exceeding 10 tonnes

### Definitions

**Aggregate trailer mass (ATM)** – the total mass of the laden trailer when carrying the maximum load recommended by the ‘manufacturer’. This will include any mass imposed onto the drawing vehicle when the ‘combination vehicle’ is resting on a horizontal supporting plane.

**Gross vehicle mass (GVM)** – the maximum laden mass of a motor vehicle as specified by the manufacturer.

**Gross trailer mass (GTM)** – the mass transmitted to the ground by the ‘axle’ or ‘axles’ of the trailer when coupled to a drawing vehicle and carrying its maximum load approximately uniformly distributed over the load bearing area, and at which compliance with the appropriate ADRs has been or can be established.

The ADRs can be accessed online at:

[www.infrastructure.gov.au/roads/motor/design](http://www.infrastructure.gov.au/roads/motor/design)



**Table A.3** Second edition ADR applicability table

ADR	PC	PD	FC1	FC2	PM	OM1	OM2	OM3	OM4	CY	MOPED	LG	HG
1 Reversing signal lamps	1/72	1/72	1/85	1/85	1/73	7/73	7/73	7/73	7/75	-	-	7/73	7/75
2 Door latched and hinges	1/71	1/71	1/85	1/85	1/73	7/83	7/83	-	-	-	-	7/74	7/75
3 Seat anchorages	1/71	1/72	1/85	1/85	1/73	7/83	7/83	-	-	-	-	7/74	-
3A Seat anchorages	1/77	-	1/86	1/86	-	1/87	-	-	-	-	-	-	-
4 Seatbelts- front seats	1/69	1/69	-	-	1/70	-	-	-	-	-	-	1/70	-
Seatbelts- front and rear seats	1/71	1/71	-	-	1/71	-	-	-	-	-	-	1/71	-
4A Seatbelts	1/74	1/74	-	-	1/74	-	-	-	-	-	-	7/74	-
4B Seatbelts	1/75	1/75	-	-	1/75	-	-	-	-	-	-	7/75	-
4C Seatbelts	1/76	1/76	1/85	1/85	1/76	7/83	7/83	-	-	-	-	7/76	-
4D Seatbelts	1/84	-	1/86	1/86	-	1/87	-	-	-	-	-	-	-
5A Seatbelt anchorages- front	1/69	1/69	-	-	1/69	-	-	-	-	-	-	1/71	-
Seatbelt anchorages - front and rear	1/71	1/71	-	-	1/71	-	-	-	-	-	-	1/71	-
5B Seatbelt anchorages	1/75	1/75	1/85	1/85	1/75	7/83	7/83	-	-	-	-	7/75	-
6 Direction turn signal	1/73	1/73	1/85	1/85	1/73	7/73	7/73	7/73	7/73	-	-	7/73	7/73
6A Direction turn signal	-	-	-	-	-	-	-	-	7/81	-	-	-	7/81
7 Hydraulic brake hoses	1/70	1/70	1/85	1/85	1/70	1/70	1/70	1/70	1/70	7/75	7/75	1/70	1/70
8 Safety glass	7/71	7/71	1/85	1/85	7/71	7/71	7/71	7/71	7/71	-	-	7/71	7/71
9 Automatic transmissions	Applies between 1/72 and 1/76 for all vehicles except motorcycles, mopeds and forward control passenger vehicles.												
10A Steering columns	1/71	1/71	-	-	-	-	-	-	-	-	-	-	-
10B Steering columns	1/73	1/73	-	-	-	-	-	-	-	-	-	-	-
11 Internal sunvisors	1/72	1/72	1/85	1/85	1/73	7/73	7/73	7/73	-	-	-	7/73	-
ADR	PC	PD	FC1	FC2	PM	OM1	OM2	OM3	OM4	CY	MOPED	LG	HG
12 Glare reduction	1/73	1/73	1/85	1/85	1/73	7/73	7/73	7/73	7/73	-	-	7/73	7/73
14 Rear view mirrors	1/72	1/72	1/85	1/86	1/73	1/87	-	-	-	-	-	-	-
15 Demisting of windscreens	1/71	1/73	1/85	1/85	1/73	7/83	7/83	-	-	-	-	7/73	7/76
16 Windscreen wipers & washers	1/73	1/73	1/85	1/86	1/74	1/87	-	-	-	-	-	-	-
17 Fuel systems- goods vehicles	-	-	-	-	-	-	-	-	-	-	-	-	7/75
18 Location and visibility of instruments	1/73	1/73	-	-	-	-	-	-	-	-	-	-	-
18A Location and visibility of instruments	1/81	1/81	-	-	-	-	-	-	-	-	-	-	-
20 Safety rims	7/70	7/70	1/85	1/86	1/73	1/87	-	-	-	-	-	-	-
21 Instrument panel	1/73	1/73	-	-	-	-	-	-	-	-	-	-	-
22 Head restraints	1/72	1/72	-	-	1/74	-	-	-	-	-	-	-	-
22A Head restraints	1/75	1/75	1/85	1/86	1/75	1/87	-	-	-	-	-	-	-
23 Pneumatic car tyres	1/74	1/74	-	-	1/74	-	-	-	-	-	-	-	-
23A Pneumatic car tyres	1/84	1/84	1/85	-	1/84	-	-	-	-	-	-	-	-
23B Pneumatic car tyres	1/86	1/86	1/86	1/86	1/86	1/87	-	-	-	-	-	-	-
24 Tyre selection	1/73	1/73	1/85	-	1/73	-	-	-	-	-	-	-	-

## Second edition ADR applicability table (cont.)

24A Tyre selection	1/86	1/86	1/86	1/86	1/86	1/87	-	-	-	-	-	-	-
25 Anti-theft locks	1/72	1/72	-	-	1/73	-	-	-	-	-	-	-	-
25A Anti-theft locks	1/78	1/78	1/85	1/86	1/78	1/87	-	-	-	-	-	-	-
26 Engine emission control	1/72	-	-	-	-	-	-	-	-	-	-	-	-
27 Engine emission control	1/74	-	-	-	-	-	-	-	-	-	-	-	-
27A Engine emission control	7/76	7/76	-	-	-	-	-	-	-	-	-	-	-
27B Engine emission control	1/82	1/82	-	-	-	-	-	-	-	-	-	-	-
27C Engine emission control	1/83	1/83	-	-	-	-	-	-	-	-	-	-	-
28 Motor vehicle noise- petrol	1/74	1/74	-	-	1/74	7/74	7/74	7/74	7/74	7/75	7/75	7/74	7/74
Motor vehicle noise- diesel	1/74	1/74	-	-	1/74	7/75	7/75	7/75	7/75	7/75	7/75	7/75	7/75
28A Motor vehicle noise	1/81	1/81	1/85	1/85	1/81	7/80	7/80	7/80	7/80	-	-	7/80	7/80
29 Side door strength	1/77	-	-	-	-	-	-	-	-	-	-	-	-
<b>ADR</b>	<b>PC</b>	<b>PD</b>	<b>FC1</b>	<b>FC2</b>	<b>PM</b>	<b>OM1</b>	<b>OM2</b>	<b>OM3</b>	<b>OM4</b>	<b>CY</b>	<b>MOPED</b>	<b>LG</b>	<b>HG</b>
30 Diesel engine smoke emissions	7/76	7/76	1/85	1/85	7/76	7/76	7/76	7/76	7/76	7/76	7/76	7/76	7/76
31 Hydraulic braking system	1/77	-	-	-	-	-	-	-	-	-	-	-	-
32 Seatbelts for heavy vehicles	-	-	-	-	-	-	-	-	-	-	-	-	7/77
32A Seatbelts for heavy vehicles	-	-	-	-	-	-	-	7/87	7/87	-	-	-	7/80
33 Motorcycle and moped braking systems	-	-	-	-	-	-	-	-	-	3/76	3/76	-	-
34 Child restraints anchorages	7/76	-	-	-	-	-	-	-	-	-	-	-	-
35 Braking systems- commercial vehicles	-	1/79	-	-	7/79	7/79	7/79	7/79	-	-	-	7/79	-
35A Braking systems- commercial vehicles	-	1/81	1/85	1/85	7/80	7/80	7/80	7/80	7/80	-	-	7/80	7/80
36 Exhaust emission control	-	-	1/85	1/85	1/79	7/78	7/78	7/78	7/79	-	-	7/78	7/79
37 Vehicle emission control	1/86	1/86	-	-	-	-	-	-	-	-	-	-	-
38 Heavy trailer braking systems	Applies to heavy trailers only.												
39 Motorcycle and moped noise	-	-	-	-	-	-	-	-	-	3/85	3/85	-	-
39A Motorcycle noise	-	-	-	-	-	-	-	-	-	3/88	-	-	-
40 Light duty vehicle emission control	-	-	1/88	-	1/88	7/88	-	-	-	-	-	7/88	-
41 Mandatory operation on unleaded petrol	-	-	-	1/88	1/88	-	-	7/88	7/88	3/88	3/88	-	7/88

## Third edition ADR applicability table

The third edition ADR applicability summaries can be accessed online at:

[https://infrastructure.gov.au/roads/motor/design/adr\\_online.aspx](https://infrastructure.gov.au/roads/motor/design/adr_online.aspx)

Please note these summaries are a guide only. The ADRs apply to vehicles in accordance with the applicability dates set out at the beginning (usually in an applicability table) of each standard.



## Appendix B – Vehicle Modifications

A modification to a heavy vehicle is any change that is made to the vehicle, including by adding or removing a component, which changes the vehicle from the manufacturer's specifications.

The *Heavy Vehicle National Law* (HVNL) creates a system that classifies modifications to heavy vehicles by how complex they are and the type of approval they need. Under this system heavy vehicle modifications fall into three distinct categories:

1. Minor modifications do not require approval provided the vehicle continues to comply with the HVNL and ADRs.
2. Modifications under the *NHVR Code of Practice for the Approval of Heavy Vehicle Modifications* (Section 86 of HVNL) require approval by an Approved Vehicle Examiner (AVE).
3. Complex modifications not covered by the *NHVR Code of Practice for the Approval of Heavy Vehicle Modifications* (Section 87 of HVNL) require approval by the NHVR and an AVE.

### Minor modifications

Minor modifications are simple modifications, including the fitment of optional equipment or alterations to a vehicle within manufacturer's specifications, that do not cause the vehicle to be non-compliant with the ADRs or the *Heavy Vehicle (Vehicle Standards) National Regulation* (known as Vehicle Standards).

Minor modifications do not require approval provided the vehicle continues to be within manufacturer's specifications and comply with the Vehicle Standards. Examples of minor modifications include: additional lighting, aerials, air conditioning, alarm systems, plastic shields for lamps and windscreens, and manufacturer's wheel/tyre options (that do not affect the gross vehicle mass or gross combination mass rating of the vehicle).

### Modifications under the Code of Practice

These modifications are more complex than minor modifications and can affect the safety of a vehicle, or compliance with the Vehicle Standards, if not performed properly. The standards for modifications included in the *NHVR Code of Practice for the Approval of Heavy Vehicle Modifications* are based on accepted vehicle engineering practices and the requirements of the Vehicle Standards.

These modifications require approval by an AVE who will issue a modification certificate and ensure a modification plate is affixed to the vehicle if it passes inspection.

At the time this manual was published, the modifications shown in Table B.1 were included in the *NHVR Code of Practice for the Approval of Heavy Vehicle Modifications*

*The National Code of Practice for Heavy Vehicle Modifications, Vehicle Standards Bulletin 6 (known as VSB6) may be obtained from the NHVR website at [www.nhvr.gov.au/vsb6](http://www.nhvr.gov.au/vsb6)*

### Complex Modifications

These are modifications not covered by the *NHVR Code of Practice for the Approval of Heavy Vehicle Modifications* that are usually significant or extensive modifications that have the potential to seriously affect the safety of the vehicle and its operation on the road by changing the vehicle's design, strength, structural integrity and handling characteristics. Complex modifications can only be approved by the NHVR.

Approval by the NHVR requires an application to, and assessment by, the NHVR. An engineering analysis (certification) by a suitably qualified person may also be required depending on the extent of the modification and the potential effect of the alterations on the vehicle's safe operation and compliance with the Vehicle Standards.

Table B.1 VSB6 modification codes

Code	Modification	Code	Modification
A1	Engine Substitution	J1	Body Mounting
A2	Air Cleaner Substitution or Additional Fitting	J2	Truck Bus Body Fitment
A3	Turbocharger Installation	K1	Seating Capacity Alteration and Seatbelt Installation
A4	Exhaust System Alteration	K2	Certification of Seat Anchorage and Certification of Seatbelt Anchorage
A5	Road Speed Limiter Installation	K3	Cabin Conversion
B1	Transmission Substitution or Additional Fitting	K5	Installation of Wheelchair Occupant Restraint System
C1	Tail Shaft Alterations	M1	Fuel System Alterations
D1	Rear Axle(s) Installation	P2	Fifth Wheel Kingpin Installation
D2	Differential Substitution	Q1	Installation of Truck Mounted Lifting Systems – Slewing
E1	Front Axle(s) Installation	R1	Goods Loading Device Installation
E2	Steering Alteration	R2	Wheelchair Loader Installation
E3	Fitment of Non-Standard Front Wheel Components	S1	Rating of Gross Vehicle Mass or Gross Combination Mass to S2 or S3 Approved Design or Within the Vehicle Manufacturer’s Specification
F1	Suspension Substitute	S2	Rating of Gross Vehicle Mass Approved Design Certification for Modified Vehicles or for Special Purpose Vehicles e.g. Motorhomes
F2	Trailer Suspension Modifications	S3	Rating of Gross Combination Mass Approved Design Certification for Modified Vehicles
G1	Air Brake System – Relocation of Air Brake Components	S7	Rating of Aggregate Trailer Mass to S12 Approved Design or Within Trailer Manufacturer’s Specification
G2	Installation of Trailer Braking Controls – Air Brakes	S8	Rating of Prime Mover for Use in Road Train
G3	Trailer Brake System Upgrading	S9	Rating of Primer Mover and Trailers for Use in B-Double
G4	Brake System Certification	S11	Rating of Trailers for Use in Road Train
G5	Auxiliary Brakes – Engine, Exhaust or Retarder Type	S12	Rating of Aggregate Trailer Mass – Design Certification for Modified Trailers
G6	Air Operated Accessories	T1	Construction of Tow Trucks
G7	Brake System Substitutions or Wheel Base Extension – Powered Vehicles	T2	Design of Tow Trucks
G8	Trailer Brake System Upgrading – Approved Design Certification for Non-Standard Trailers	Queensland specific codes	
H1	Wheel Base Extension Outside the First Manufacturer’s Option	S10	Concessional Livestock Loading – Vehicle Rating
H2	Wheel Base Reduction Less Than First Manufacturer’s Option	S13	Bus Life Vehicle Rating
H3	Wheel Base Alterations Within First Manufacturer’s Option		
H5	Trailer Chassis Frame Modification		
H6	Certification of Front Underrun Protection on Heavy Vehicles and Certification of Bullbars for Fitting to ADR 84/00 Compliant Vehicles		





## For more information

[www.nhvr.gov.au](http://www.nhvr.gov.au)

**Email** [info@nhvr.gov.au](mailto:info@nhvr.gov.au)

**Tel** 1300 MYNHVR (1300 696 487)

7am to 5pm (AEST), standard 1300 call charges apply  
(please check with your phone provider).

**Post** National Heavy Vehicle Regulator  
PO BOX 492, Fortitude Valley Qld 4006

