

**MAKING
MAKERS**



DIY X SHAPED SIDE TABLES

MAKER PLAN

VERSION 1.0 - UPDATED DEC 2020

USE AT YOUR OWN RISK DISCLOSURE: THESE PLANS REPRESENT MY IDEAS AND EXPERIENCES ONLY. I AM NOT A PROFESSIONAL AND THE INFORMATION IN THESE PLANS SHOULD NOT BE CONSIDERED ADVISE. NONE OF THE AUTHORS, OR ANYONE ELSE CONNECTED WITH MAKING MAKERS AND THESE PLANS IN ANY WAY

MATERIALS LIST

1 1X5X8 PINE BOARD

1 1X2X8 <SAME>

2 2X2X8 LUMBER

WOOD GLUE

KREG SCREWS 1 1/2"

SANDPAPER
(OPTIONAL)

WHITE SPRAY PAINT

AMBER SHELLAC

TOOLS USED

MITRE SAW

TABLE SAW

DRILL

KREG JIG

(OPTIONAL)

SQUARE

LEVEL

CLAMPS

PLANER

JOINTER

MAKING
MAKERS

Cutlist — 1x5x8

CUTLIST

Generating the following components:

[1] → 20" (x2)

The following stock board lengths are available:

96"

Results:

96" board = [1] 20" + [1] 20" + 0.25" cut losses + 55.75" excess



Board Count:

1x 96" (8')

Generated at <http://jonathan.overholt.org/projects/cutlist>

Cutlist — 1x2x8

Generating the following components:

[1] → 9" (x4)

[2] → 18" (x2)

The following stock board lengths are available:

96"

Results:

96" board = [2] 18" + [1] 9" + [1] 9" + [1] 9" + [1] 9" + [2] 18" + 0.75" cut losses + 23.25" excess

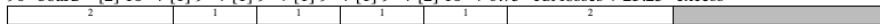

Board Count:

1x 96" (8')

Cutlist — 2x2x8

Generating the following components:

[1] → 6" (x4)

[2] → 15" (x4)

[3] → 23" (x4)

The following stock board lengths are available:

96"

Results:

96" board = [3] 23" + [3] 23" + [3] 23" + [3] 23" + 0.5" cut losses + 3.5" excess

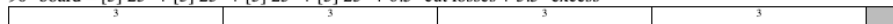

96" board = [2] 15" + [2] 15" + [2] 15" + [1] 6" + [1] 6" + [1] 6" + [1] 6" + [2] 15" + 1" cut losses + 11" excess

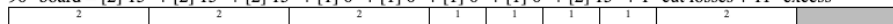

Board Count:

2x 96" (8')

Generated at <http://jonathan.overholt.org/projects/cutlist>

Notes

TIP: I prefer to rip 2x4x8's at 1.5" (actual) on table saw first to create my own 2x2x8's. I get less twisted pieces that way.

MAKING
MAKERS

MEASUREMENTS

WATCH VIDEO FOR BUILD INSTRUCTIONS

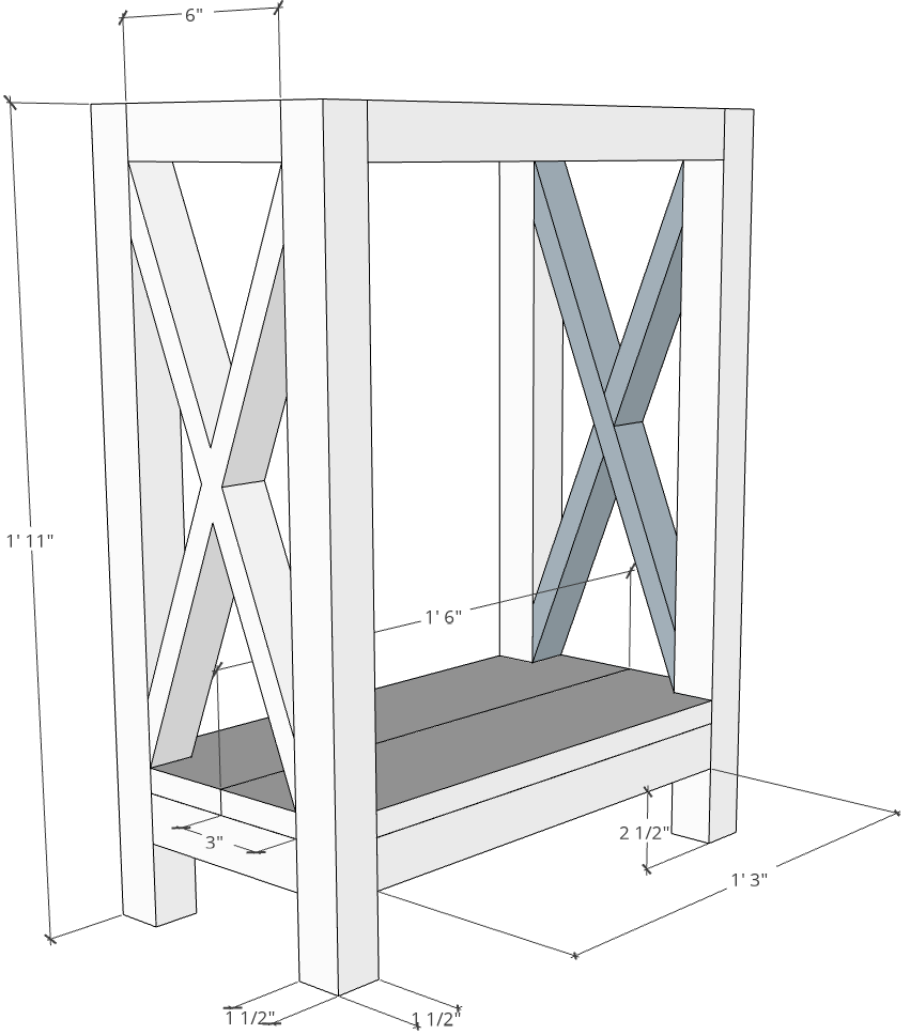

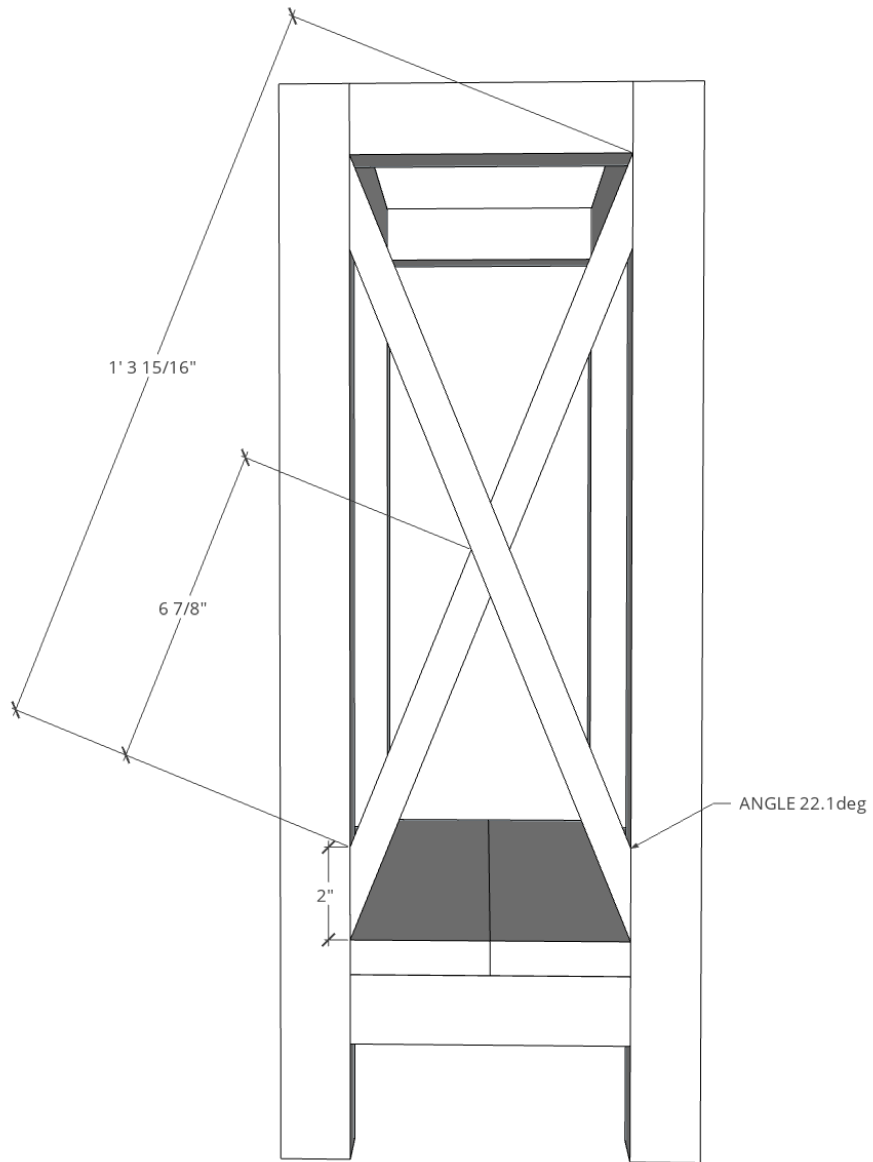

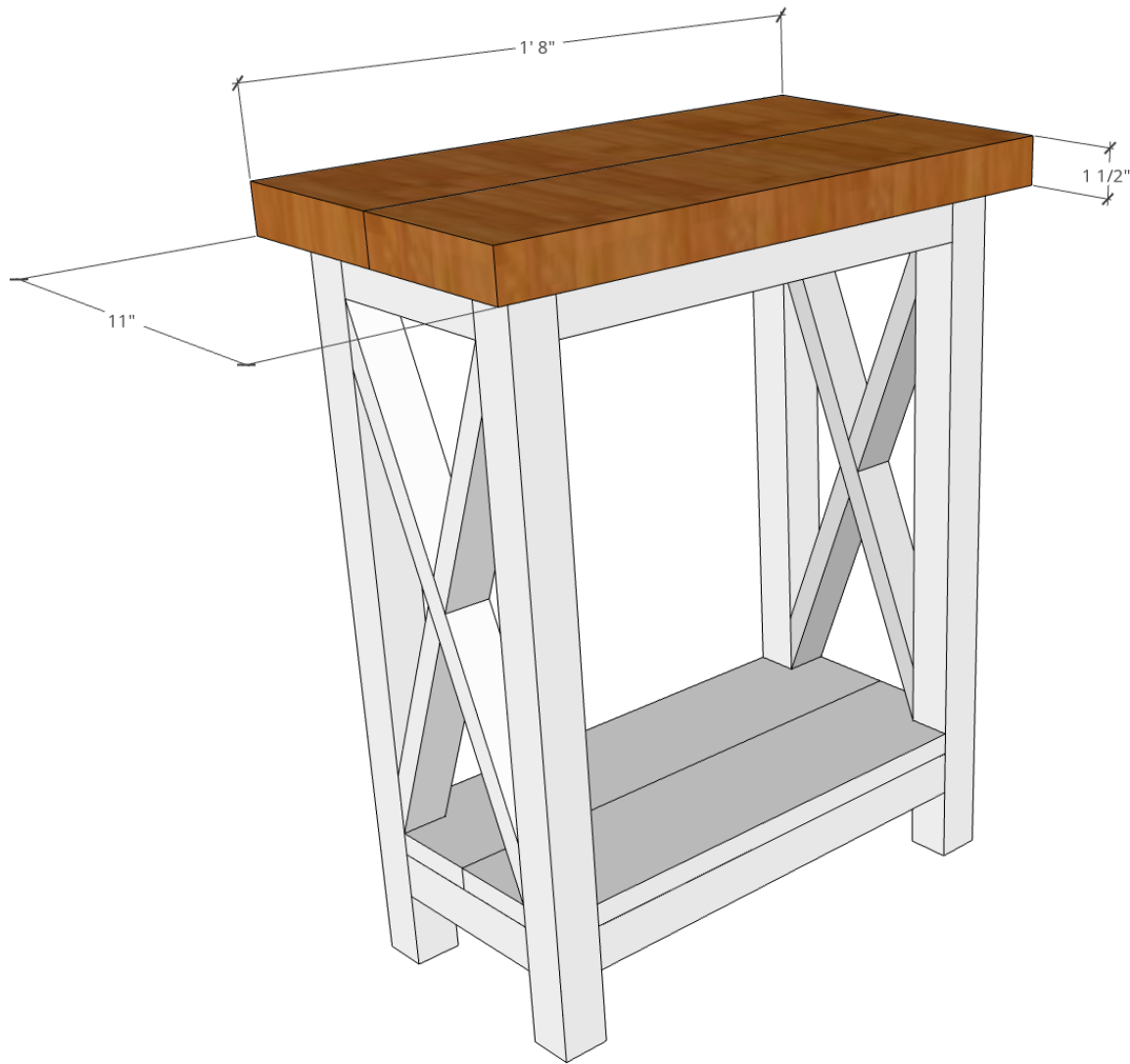

CONGRATULATIONS MAKER, YOU HAVE MADE YOUR VERY OWN X-SHAPED SIDE TABLES!!!

I AM STILL NEW TO MAKING PLANS FOR FOLKS, SO IF YOU SEE ANY ERRORS OR HAVE ANY QUESTIONS PLEASE BE SURE TO EMAIL ME AT MAKINGMAKERSDIY@GMAIL.COM

NOTE: THE 'MAKER MILL' SHOWN IN THE ACCOMPANYING YOUTUBE VIDEO NOW LETS ME TURN EVERYDAY LOGS INTO USABLE WOODWORKING MATERIAL. I PERSONALLY HAVE USED THIS MILL TO HELP CREATE LIVE EDGE END TABLES, CHARCUTERIE BOARDS, CUTTING BOARDS, KNIFE BLOCKS. SOON I HOPE TO MAKE CLOCKS, CHESS BOARDS, AND EVEN HATCHET THROWING TARGETS. I CANT WAIT TO SEE WHAT YOU CREATE MAKERS!!!

REMEMBER TO WATCH MY CHAINSAW SERIES ON YOUTUBE FOR "IN USE" EXAMPLES WHICH MAY CLARIFY THESE INSTRUCTIONS. MOD THESE AS YOU WANT TO, AND PLEASE SEND ME PICS OF YOUR COMPLETED PROJECTS. I CAN'T WAIT TO SEE WHAT YOU MAKERS COME UP WITH!!!

~ MIKE FROM MAKING MAKERS

**MAKING
MAKERS**