



Industrial Data Logger

IIoT 4.0



Contents

1. Introduction	2
2. Features	3
3. Benefits	1
4. Applications.....	1
5. Block Diagram	2
6. Pin-out.....	3
7. Programming IDE	5
8. Product Specification	5
8.1. Digital Input.....	5
8.2. Digital Output.....	7
8.3. Analog Input.....	8
8.4. SD Card.....	10
8.5. RTC	11
8.6. FRAM.....	12
8.7. PWDT (Physical Watch Dog Timer)	12
8.8. Flash	13
8.9. Ethernet	14
8.10. ESP32/XBEE/LoRA/RS485.....	15
8.11. GSM.....	18
8.12. RS485 Modbus	19
8.13. RS232/FT232/Program.....	20
8.14. DAC.....	21
8.15. Status LED Display.....	23
8.16. RDL Bus.....	1
8.17. STM32	2
9. Order Information Table	5
10. References and Datasheets	6



1. Introduction

RDL data logger is a comprehensive real time industrial automation tool. The product is designed to seamlessly integrate with the IoT and Analytical processing systems. Supporting multiple I/O options, interfaces data logger is a perfect fit to build custom automation solutions.

The state of art design incorporates carefully selected devices with minimum power requirements, stable operation in industrial environment and up to date feature set. The product architecture incorporates functionally partitioned across multiple controllers to ensure minimum down-time and interruptions on the production lines.

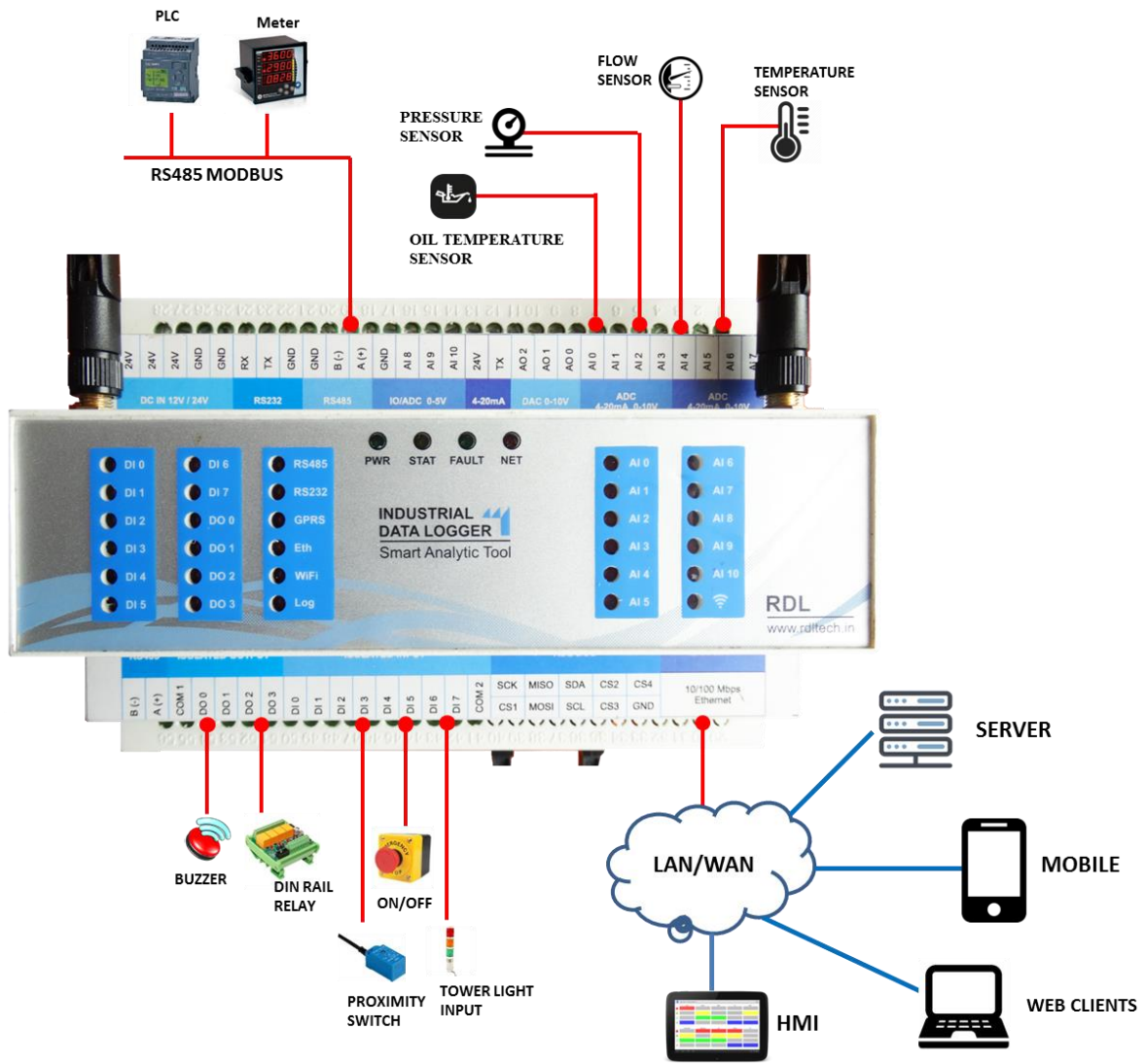



2. Features

- 8x ADC 0-10v / 4-20ma
- 3x DAC 0-10V
- 1x 4-20ma Transmitter
- 3x ADC/IO 0-5v
- 8x DI 24v & 3x DO
- 2x RS485 Modbus*
- 10/100 MBPS Ethernet
- 1x RS232
- 1x Quad band GSM /GPRS Modem*
- 1x External PWDT
- 1x SD card , RTC ,FLASH & FRAM
- 1x xbee /ESP32/Lora/RS485*
- 12/24V DC to DC Converter
- RDL Extension BUS with SPI /I2C /IO
- Mega2560 Controller
- Enable with STM32F030RCTx Co-controller for Advanced programming





3. Benefits

Reduce Supplier dependency and cost by complete ownership of the solution. Automation requirements keep increasing and changing with time, engaging external supplier is cost and loss of productive time. Open Platform Model allows to build custom solutions with minimal R&D cost. Our platform and tools will enable a base solution to be built and deployed with 1 person month of effort with basic programming skills.

- Simplified logging network as RDL Data Logger supports multiple features
- Paper-less Production environment
- Production count, rejections
- Machine availability and Downtimes
- Preventive maintenance
- Performance Forecasting
- Enable Management by IT

4. Applications

- Production and process monitoring.
- Utilities monitoring.
- Condition monitoring.
- Environment monitoring.
- Industrial Smart grid
- Leakage detection.
- Cold storage monitoring.
- District metering.
- Water treatment.
- Generator monitoring.
- Green House.
- Warning message in case of calamities.
- Standard SCADA Applications



5. Block Diagram

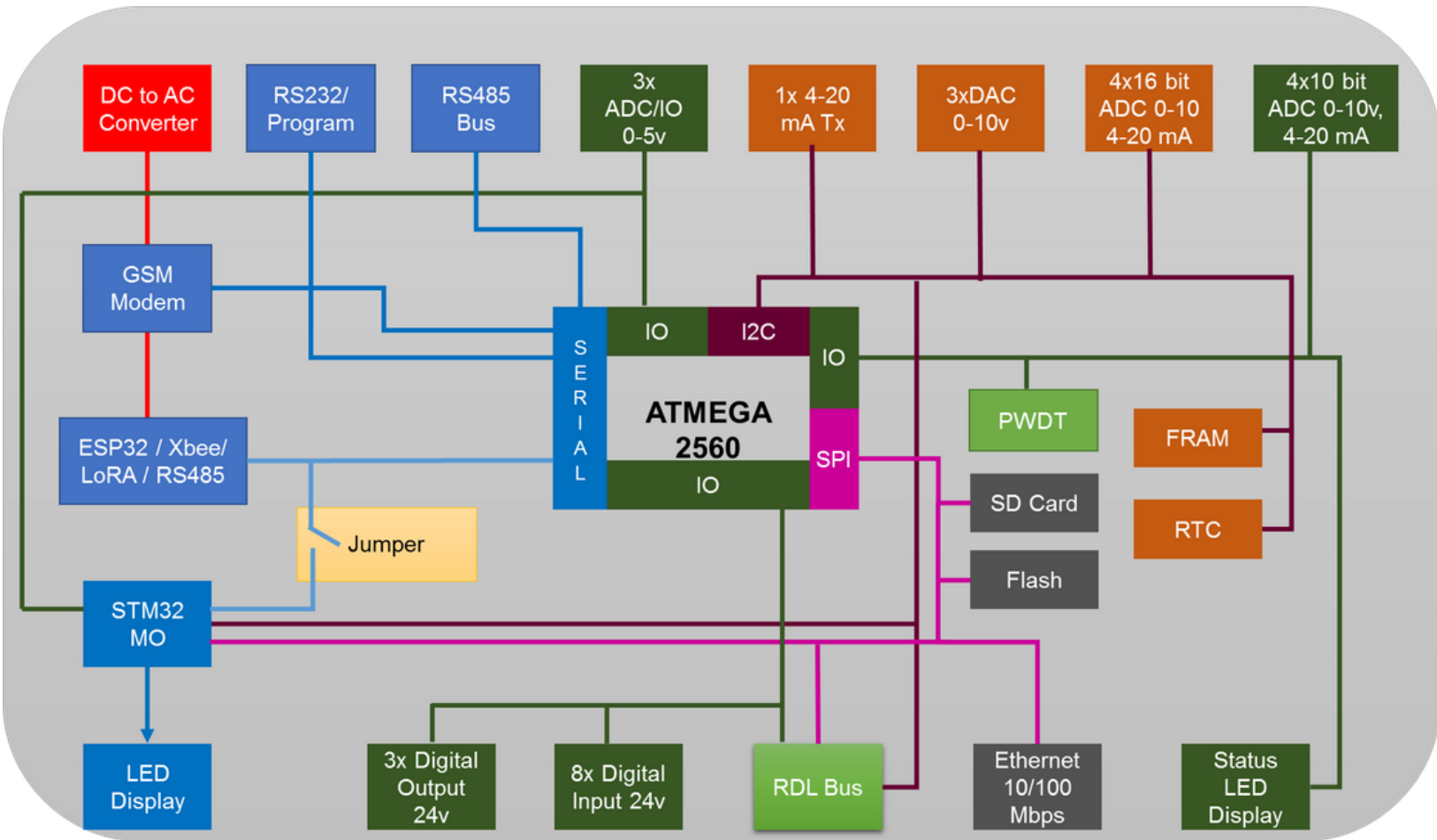



6. Pin-out

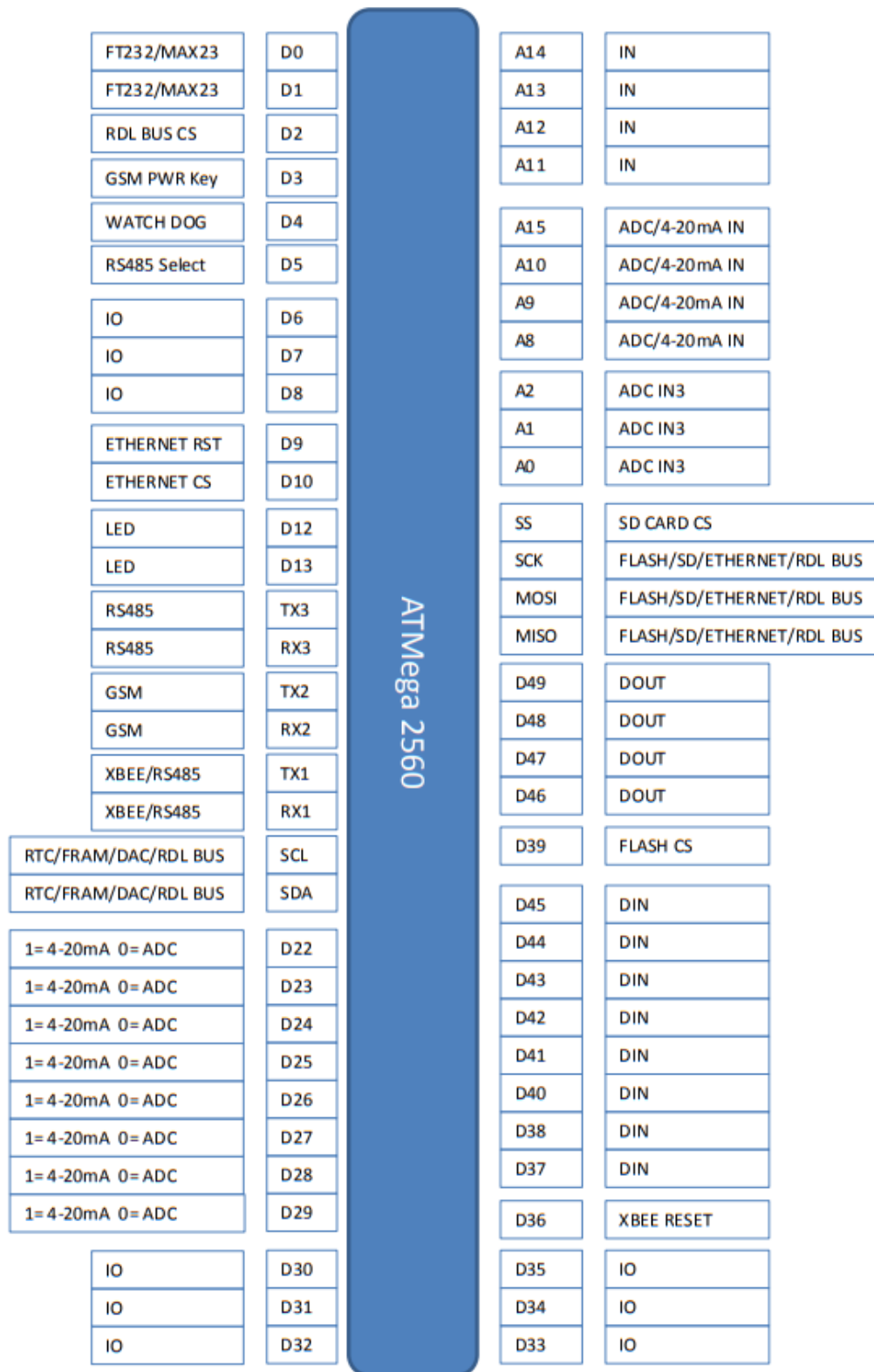



Pins	Functionality
D0, D1	Serial Pins. To which either FT232 can be connected or a MAX232 can be connected.
D2	RDL Bus chip select Pin
D3	RDL chip select or slave select pin
D4	GSM power key (Software Switch). High-to-Low on this pin powers ON the GSM.
D5	RS485 select (control) pin for serial communication.
D6 – D8, D30 – D35	Left open to the user and can be configured either as an input or output.
D9	Reset pin for Ethernet
D10	Chip select or slave select pin for Ethernet
D12, D13	LED pins which could be programmed for status indication as required.
TX3, RX3	RS485 serial communication
TX2, RX2	GSM serial communication
TX1, RX1	Can either be connected to RD485 or XBEE for serial communication
SCL, SDA	Can be connected to I2C based RTC, FRAM, DAC and RDL bus
D22 – D29	Control pins to select ADC as a 0-10V Voltage reading channel or 4-20mA Current reading channel.
D36	XBEE reset pin
D37, D38	Digital input pins
D39	Chip select or slave select pin for Flash
D40 – D45	Digital input pins
D46 – D49	Digital Output pins
MISO, MOSI, SCK	SPI pins to where number of devices could be connected
SS	Chip select or slave select pin for SD Card
A0 – A2	Analog Input Pins left open to the user
A8, A9, A10, A15	Analog Input Pins which could be configured (using pins d22-d29) to read either voltage or current.
A11 – A14	Analog Input Pins left open to the user



7. Programming IDE

The hardware supports various Open Source Programming IDE including Arduino IDE, Atmel Studio and Arduino Compatible Compiler for LabView. For more information on this follow “**Open Source Programming IDE**” section of the following link.

<https://rdltech.in/data-logger-iiot-4-0>

8. Product Specification

8.1. Digital Input

Specification

- Channels: 8
- Input Voltage: 0-24V
 - Logic High: >11V
 - Logic Low: < 3V
- Isolation : 3750 VRMS
- Supports Inverted DI Status
- Supported Connection: Dry and Wet both

Functional Diagram

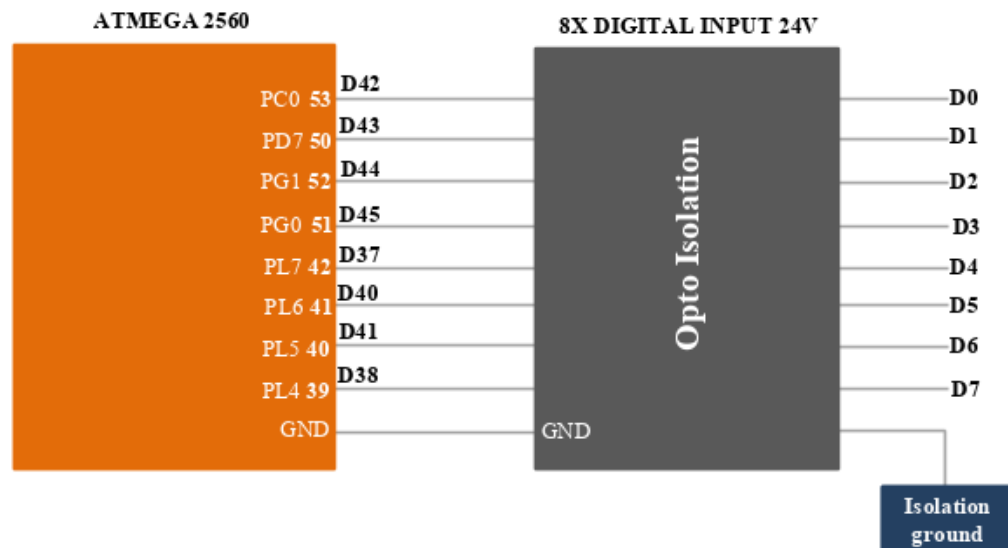

Application Wiring

DRY CONNECTION

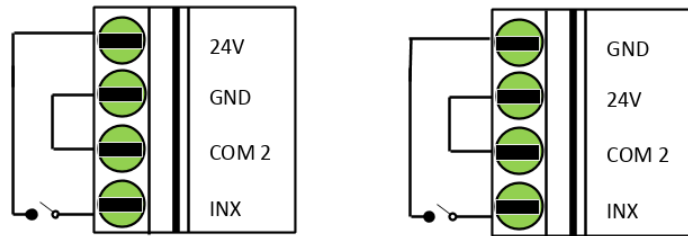

WET CONTACT



TLC/CMOS

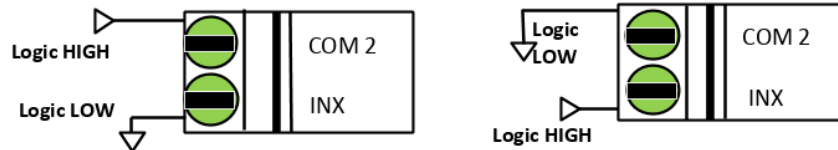

NPN OUTPUT

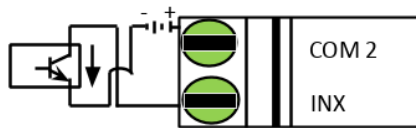

PNP OUTPUT

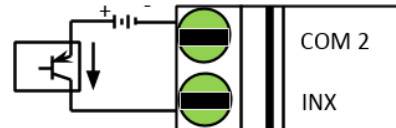

Use Case

1. Measuring Frequency

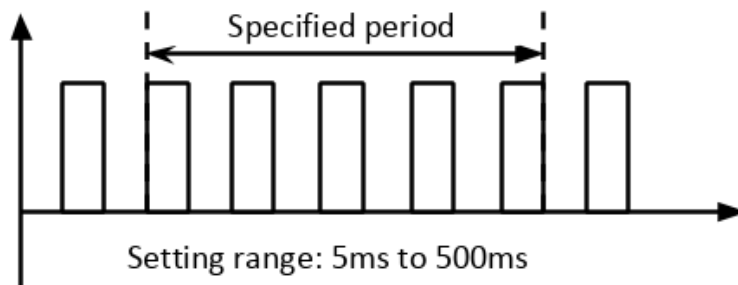



Example Code

You may look into the following link for example on reading a digital pin.

<https://www.arduino.cc/reference/en/language/functions/digital-io/digitalread/>

8.2. Digital Output

Specification

- Channels: 3
- Open Collector
- Isolation : 3750 VRMS
- Absolute maximum voltage - 35V, Current - 100mA
- Cut-Off Frequency : 10KHz

Functional Diagram

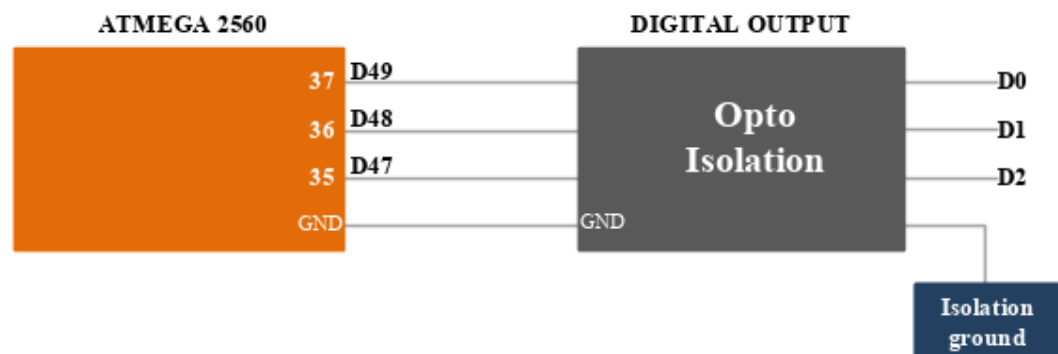

Application Wiring

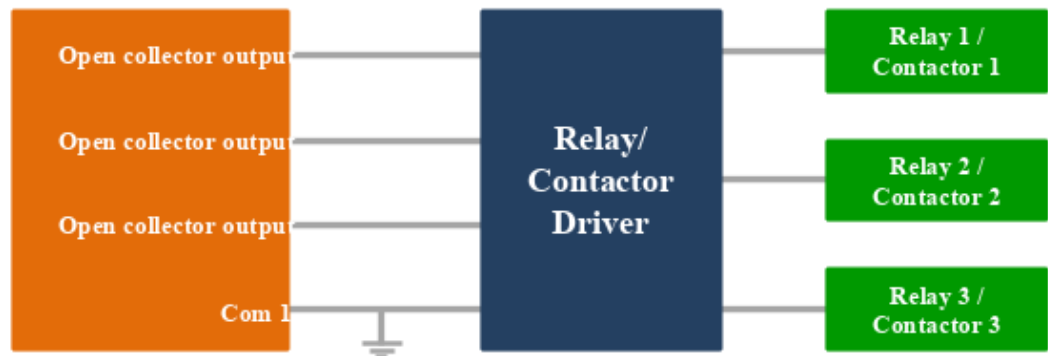



Example Code

You may look into the following link for more details on writing to digital pin.

<https://www.arduino.cc/en/Reference/digitalWrite>

8.3. Analog Input

Specification

- Channels: 8+3
- **Group 1 :**
 - Channel : 4
 - Input : Voltage(0-10V) / Current(4-20mA)
 - Resolution : 16 bits
 - Sampling Rate – 860 sample/sec

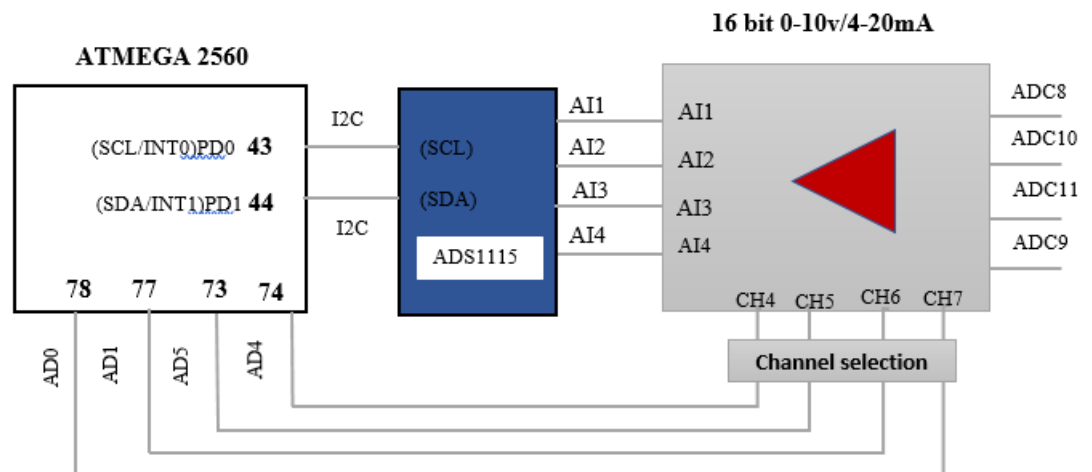



- **Group 2 :**
 - Channel : 4
 - Input : Voltage(0-10V) / Current(4-20mA)
 - Resolution : 10 bits
 - Sampling Rate – 9.6KHz (13 clocks)

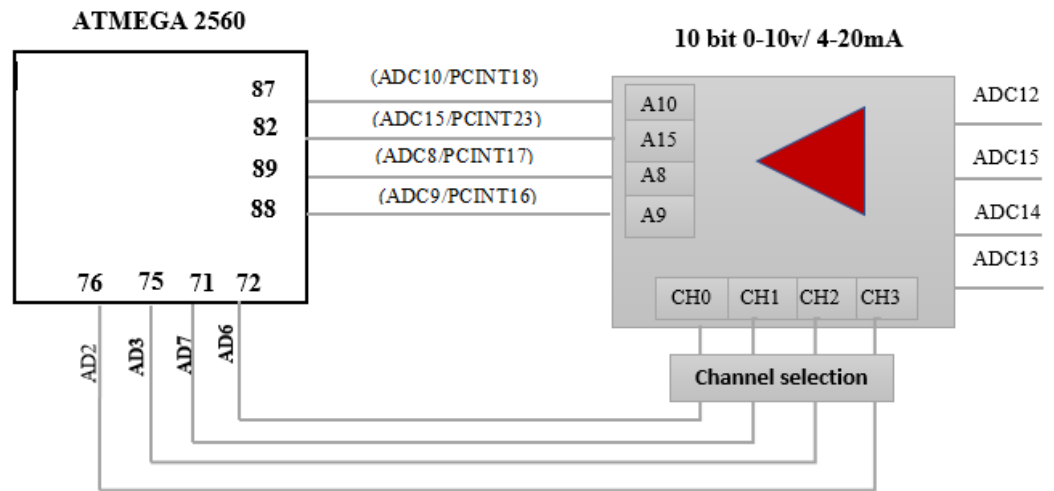

- **Group 3 :**
 - Channel : 3
 - Input : Voltage(0-5V)
 - Resolution : 10 bits
 - Sampling Rate – 9.6KHz (13 clocks)

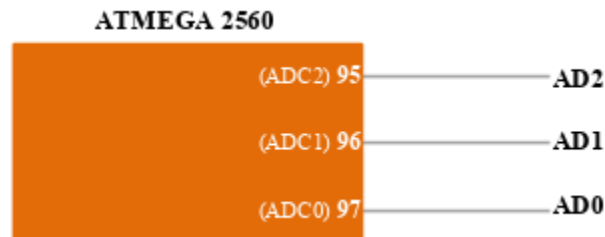

Application Wiring

1. Interfacing ADC with Sensor

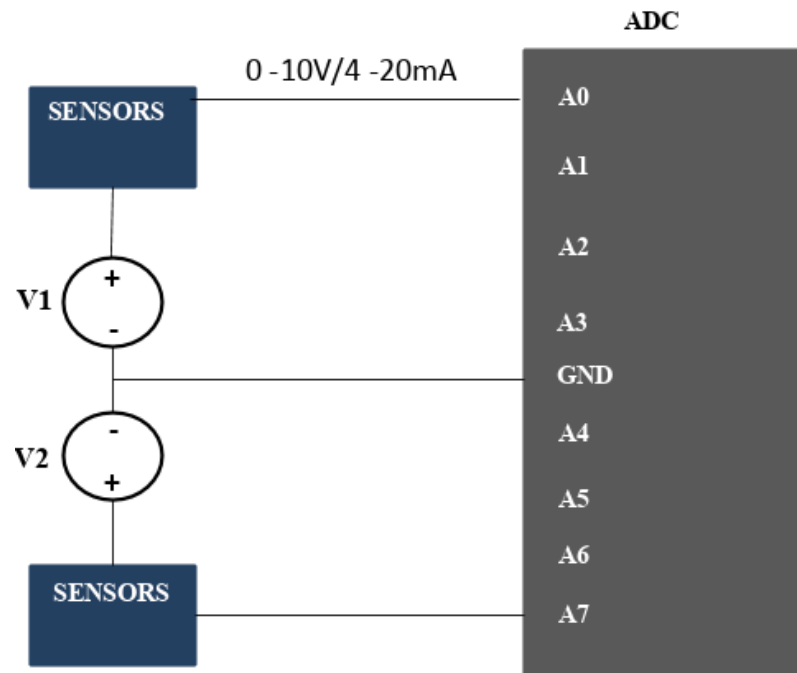

Example Code

You may look into the following link for more details on reading analog pin.

<https://www.arduino.cc/en/Tutorial/ReadAnalogVoltage#toc5>

8.4. SD Card

Specification

- SPI Serial Interface
- Supports Fat File system

Functional Diagram

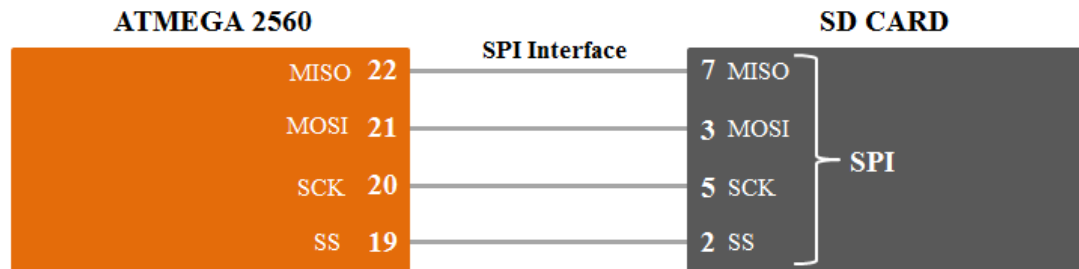

Example Code

You may look into the following link for example on SD Card.

<https://www.arduino.cc/en/Reference/SD>

8.5. RTC

Specification

- DS1307 with I2C Serial Interface
- Counts Seconds, Minutes, Hours, Date, Month, Day, and Year with Leap-Year Compensation.
- 56-Byte, Battery-Backed, NV RAM for Data Storage
- Consumes <500nA in Battery Backup Mode with Oscillator Running

Functional Diagram

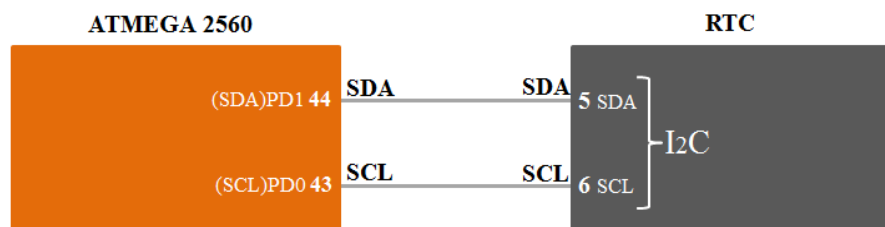

Example Code

You may look into the following link for example code on RTC.

<https://www.arduino.cc/en/Reference/RTC>

8.6. FRAM

FRAM is specifically used for applications such as production counting, production rejection where variable subjected to continuous write cycle

Specification

- MB85RC256V, I2C compatible with Bit configuration : 32,768 words × 8 bits
- Operating frequency : 1 MHz (Max)
- Read/write endurance : 1012 times / byte
- Number of write cycles: 100 Trillion times
- Operating power supply voltage : 2.7V to 5.5V, current 200 μ A
- Data Retention: 10 years (+85°C), 95 years (+55°C), over 200 years (+35°C).

Functional Diagram

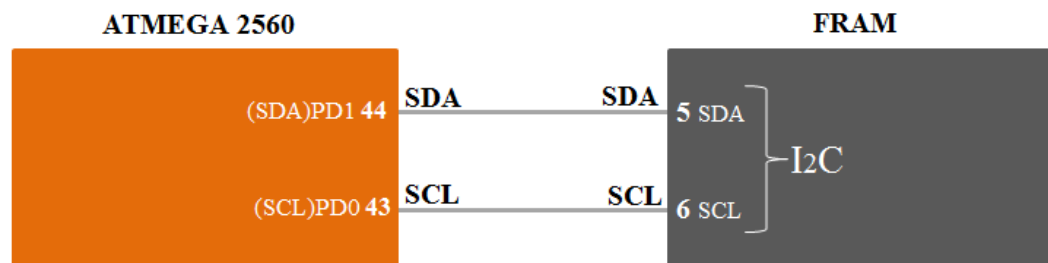

Example Code

You may look into the following link for example on RTC

https://github.com/adafruit/Adafruit_FRAM_I2C/blob/master/examples/MB85RC256V/MB85RC256V.ino

8.7. PWDT (Physical Watch Dog Timer)

External physical watchdog is connected along with inbuilt watchdog timer. There are many instances where we need to set watch dog time for more than 8 seconds (typically bulk file upload takes in minutes). As inbuilt WDT is limited to maximum of 8Sec, we have gone a step further to support watch dog time up to 3 minutes.

Note: User must program PWDT to refresh before the timer (3 min) expires.



Specification

- PWDT supports up to 3minutes.
- PIC12F1840 used for PWDT
- Refresh time : 1 pulse in every 3 minutes
- Operating temperature range: -40 to 125 °C

Functional Diagram

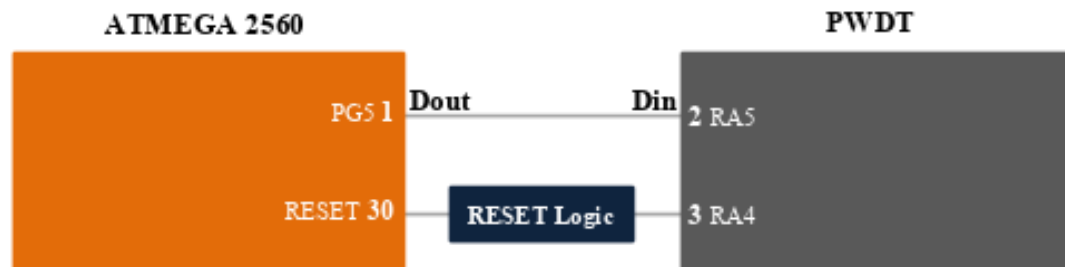

Example Code

You may look into the following link for examples on watchdog timer.

<https://folk.uio.no/jeanra/Microelectronics/ArduinoWatchdog.html>

8.8. Flash

Flash is specifically used for embedded server.

Specification

- SST25VF080B - SPI Compatible: Mode 0 and Mode 3
- Memory: 8MBit
- High Speed Clock Frequency – 50 MHz
- Single Voltage Read and Write Operations – 2.7-3.6V
- Endurance: 100,000 Cycles (typical) – >100 years Data Retention
- Low Power Consumption: – Active Read Current: 10 mA (typical)
- Flexible Erase Capability – Uniform 4KB, 32KB overlay blocks and 64KB overlay blocks
- Software Write Protection

Functional Diagram

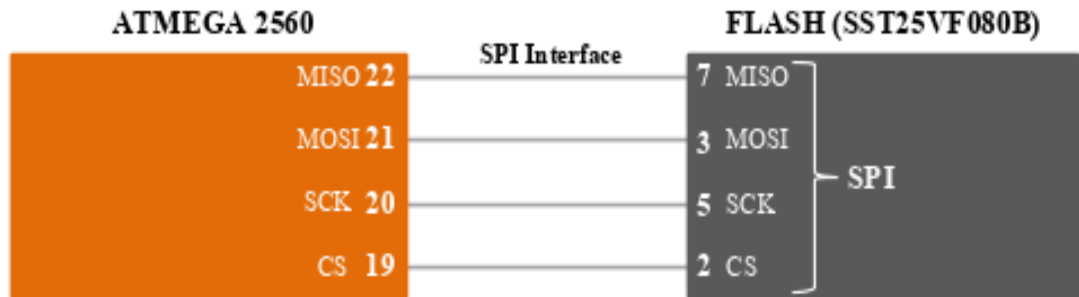

Example Code

You may look into the following link for example on how to use flash.

<https://github.com/nullboundary/SST25VF>

8.9. Ethernet

Ethernet is specifically used for establishing secured physical network connectivity with local network infrastructure

Specification

- W5500 IC with SPI serial interface
- IEEE 802.3 Gigabit Ethernet Compliant
- Communication protocols: TCP/IP, HTTP, FTP, MQTT, UDP,JSON....
- 3.3V operation with 5V I/O signal tolerance
- Low Power Consumption <200mW at 1.25Gbps.

Functional Diagram

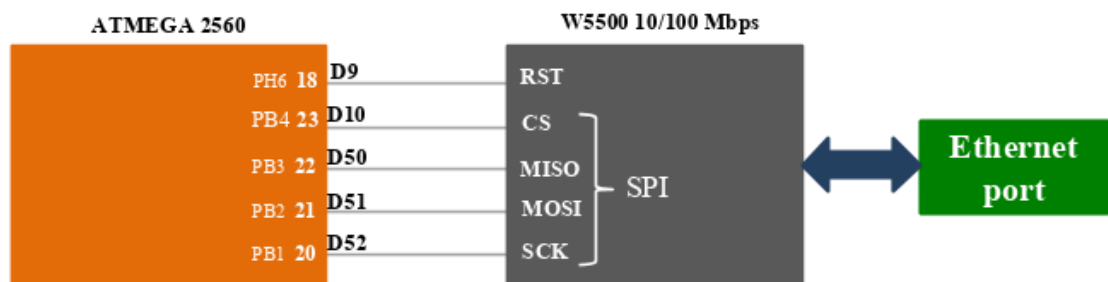



Use Case

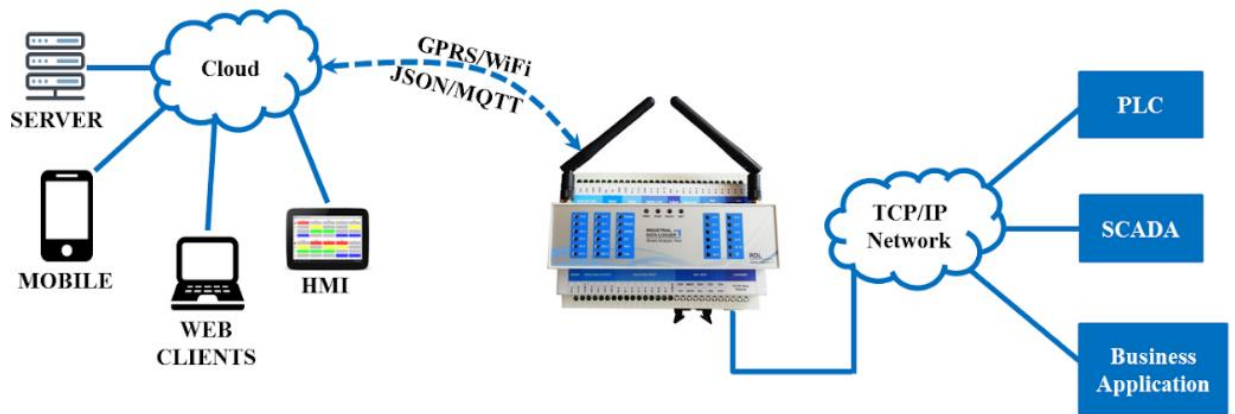

Example Code

You may look into the following link for examples on Ethernet.

<https://www.arduino.cc/en/Reference/Ethernet>

8.10. ESP32/XBEE/LoRA/RS485

This is Add-On pluggable module. One among ESP32, XBEE, LoRA or RS485 is comes with the product. For more details on this, look into [Order Information Table](#).

This is specifically used for wireless connectivity with existing infrastructure.

Functional Diagram

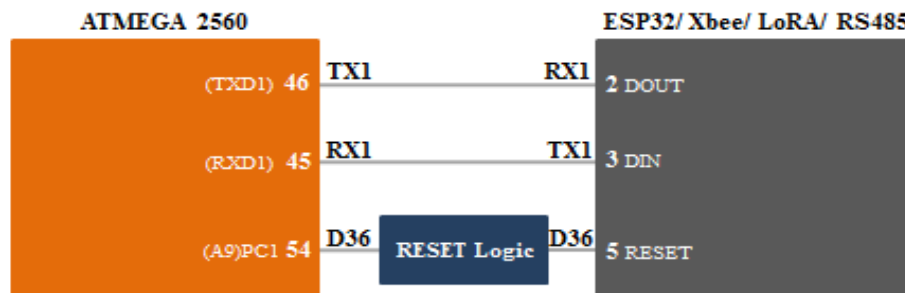

Use Case

1. Interfacing Industrial Data Logger with Bluetooth

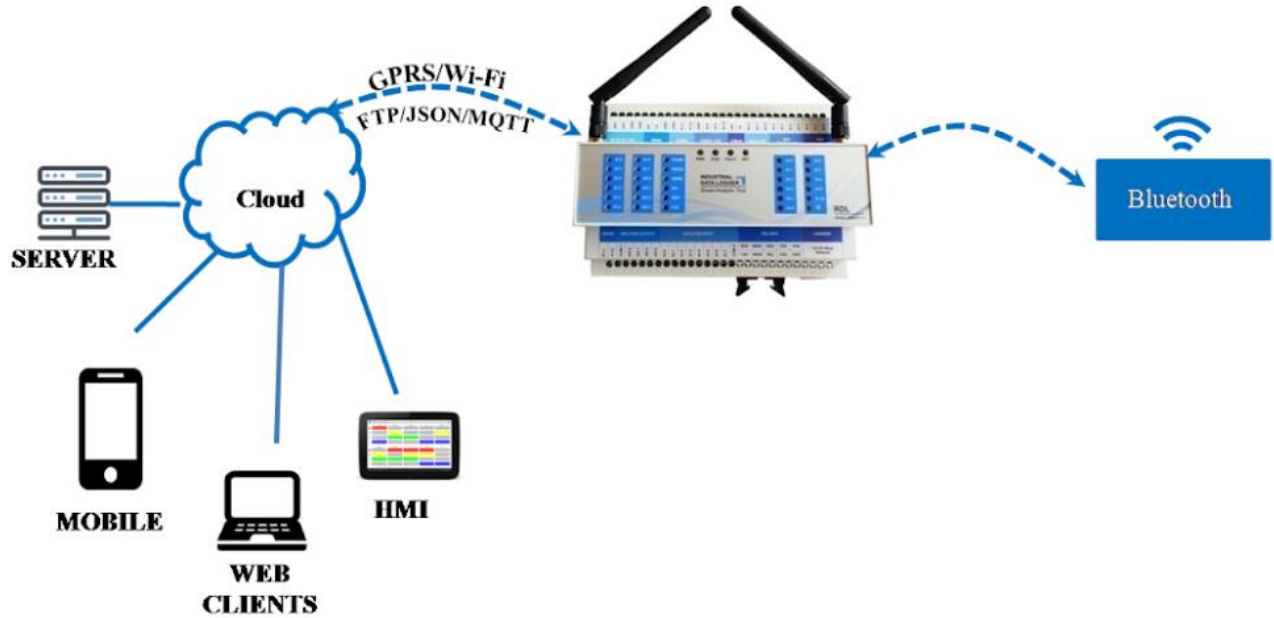

2. Interfacing Industrial Data Logger with LoRA

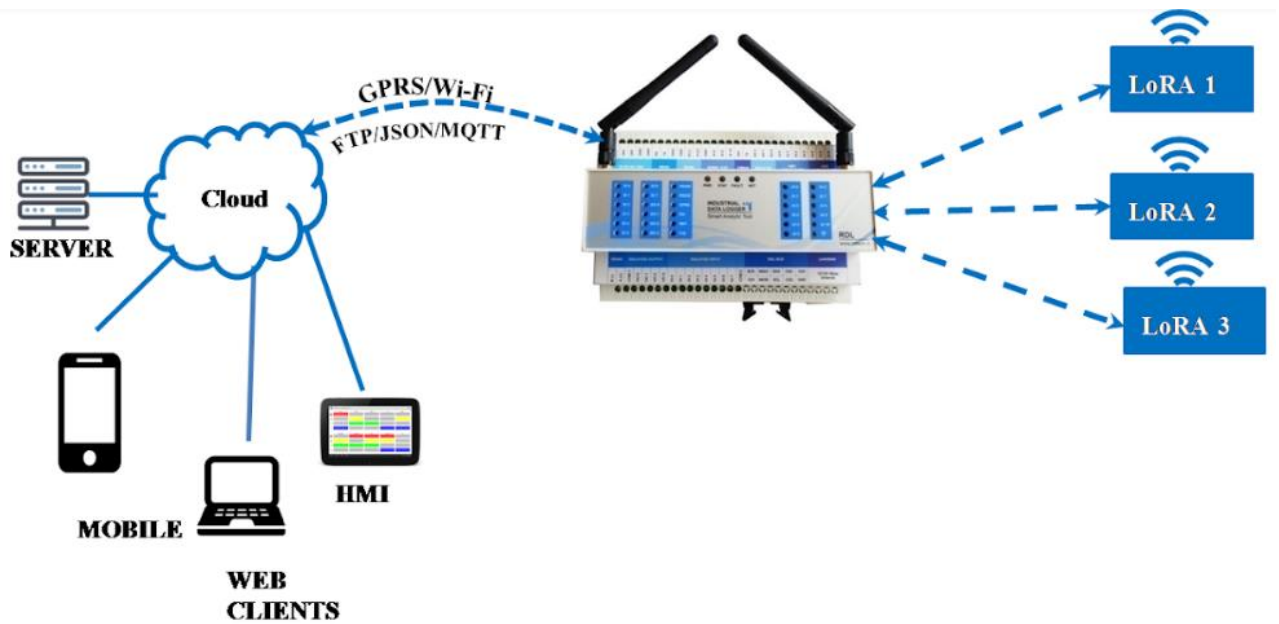

3. Interfacing Industrial Data Logger with Xbee

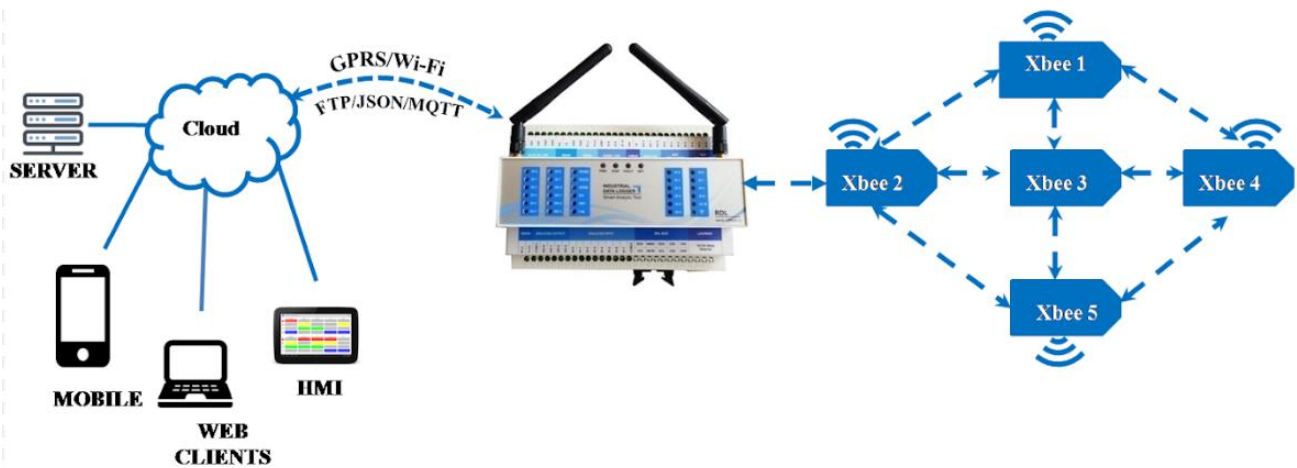

4. Interfacing Industrial Data Logger with Wi-Fi (ESP32)

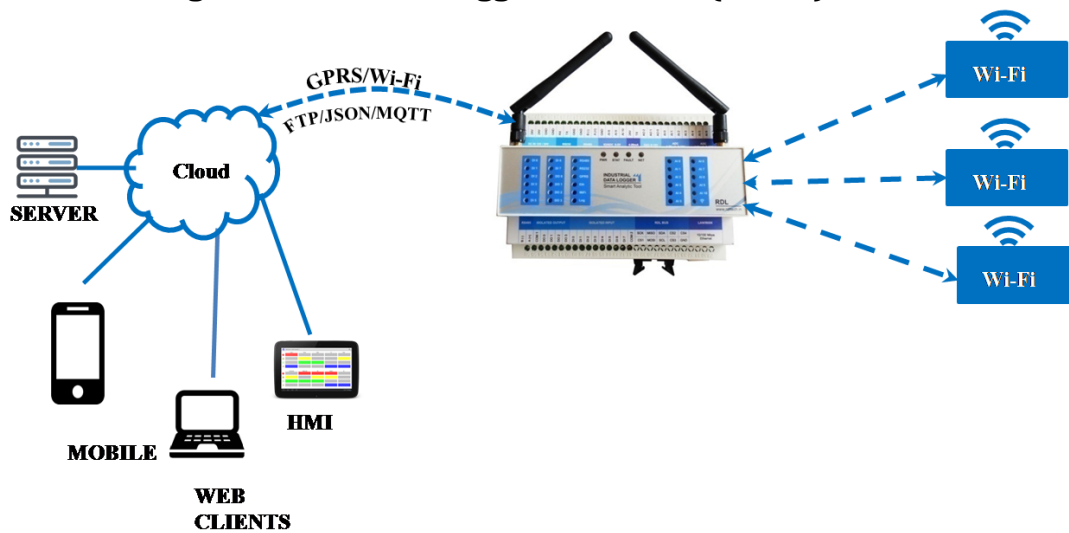

Example Code

You may look into the following link for examples on esp8266.

<https://www.arduino.cc/en/Reference/WiFiServer>

8.11. GSM

This is specifically used for M2M and remote data logging and control applications.

Specification

- Quectel M95, Quad-Band 850/900/1800/1900MHz.
- Serial interface for direct communication with PC or MCU.
- Configurable baud rate.
- Power controlled using 29302WU IC.
- ESD Compliance.
- Enabled with Audio jack.
- With push pull SIM card holder.
- With Stub antenna and SMA connector.
- Input Voltage: 12V DC.

Functional Diagram

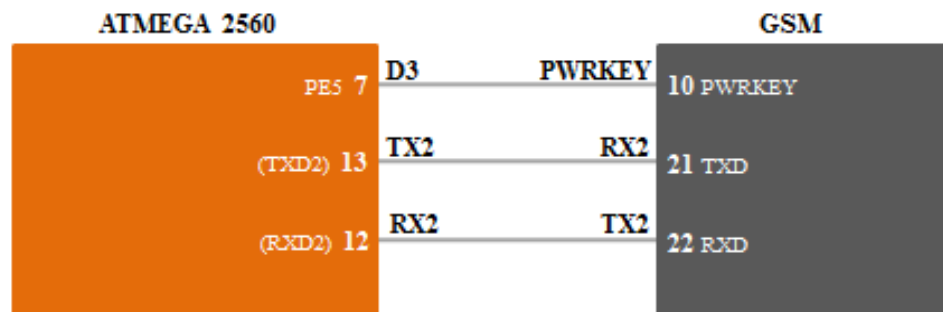

Use Case

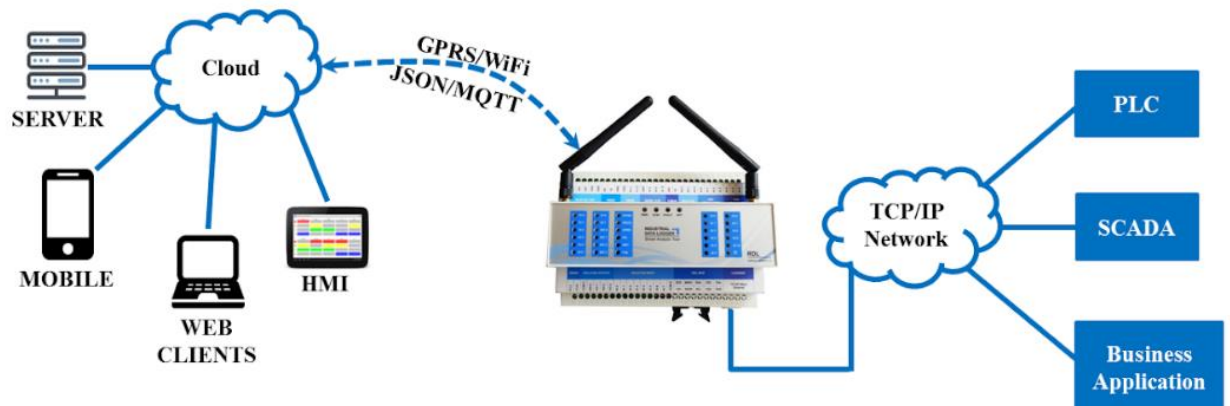



Example Code

You may look into the following link for examples on GSM.

<https://www.arduino.cc/en/Tutorial/GSMExamplesSendSMS>

8.12. RS485 Modbus

- Modbus is an Industrial standard serial communication protocol.
- Open protocol
- Information is stored in the Slave device in four different tables. Two tables store on/off discrete values (coils) and two store numerical values (registers). The coils and registers each have a read-only table and read-write table.
- Each table has 9999 values. Each coil or contact is 1 bit and assigned a data address between **0000-270E**. Each register is 1 word = 16 bits = 2 bytes and also has data address between **0000** and **270E**.
- Supported Functions are
 - Coils
 - Discrete inputs
 - Input Registers
 - Holding Registers.

Specification

- LTC485 IC.
- Supports slave address up to 32.
- Supports Modbus protocol with RTU and ASCII formats.
- Configurable baud rate from 4800 to 115200.
- Configurable packet format (data bits, parity bit, stop bits).

Functional Diagram

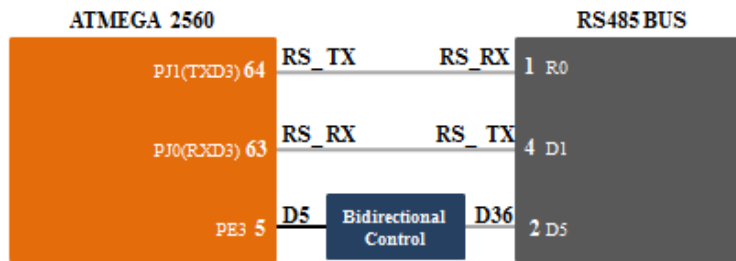

Use Case

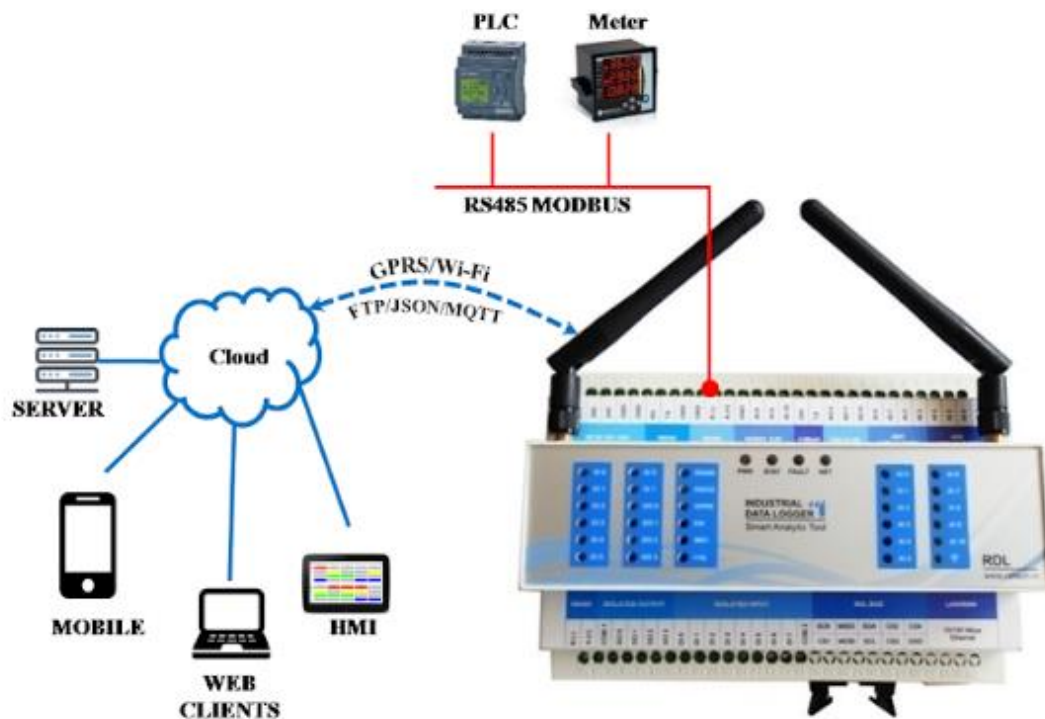

Example Code

You may look into the following link for examples on Modbus examples.

<https://playground.arduino.cc/Code/ModbusMaster>

8.13. RS232/FT232/Program

Used for programming the board. When in user mode, the port could be used for data communication.

Functional Diagram

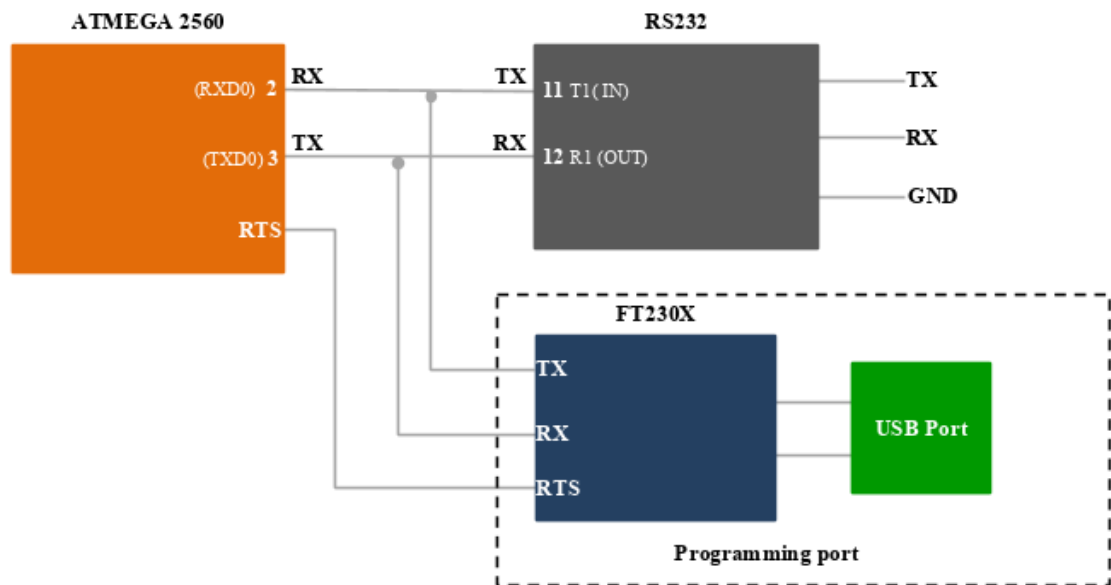

Example Code

You may look into the following link for examples on FT232/MAX232 serial communication.

<https://www.arduino.cc/reference/en/language/functions/communication/serial/>

<https://www.arduino.cc/en/Tutorial/SoftwareSerialExample>

8.14. DAC

Specification

- MCP4768 with I2C serial interface
- Quad, 12-bit voltage output
- Channel: 4 (buffered outputs)
- Internal Voltage Reference
- Output Voltage Range using 0-10V

Functional Diagram

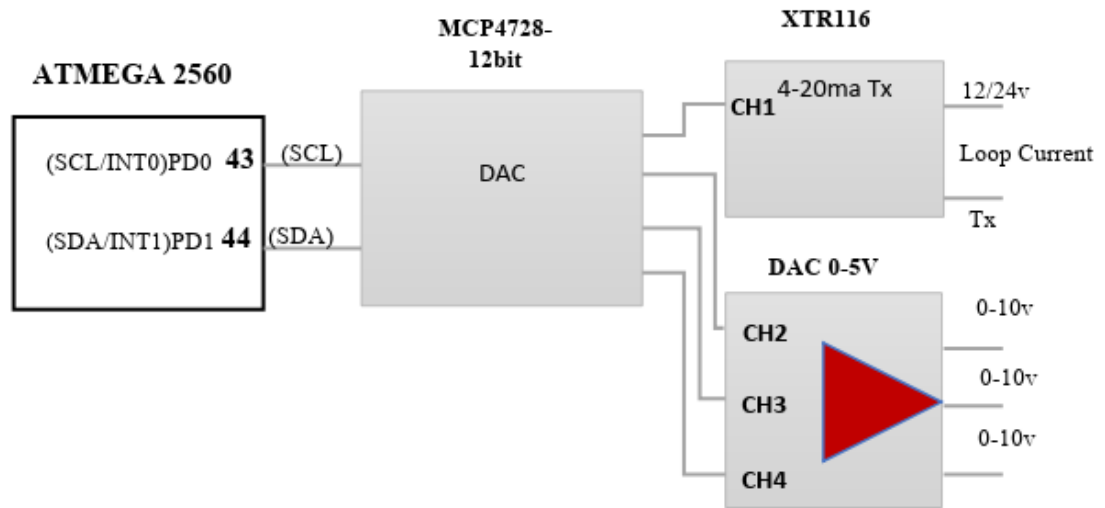

Application Wiring

1. Interfacing DAC with Motor Speed Control Module

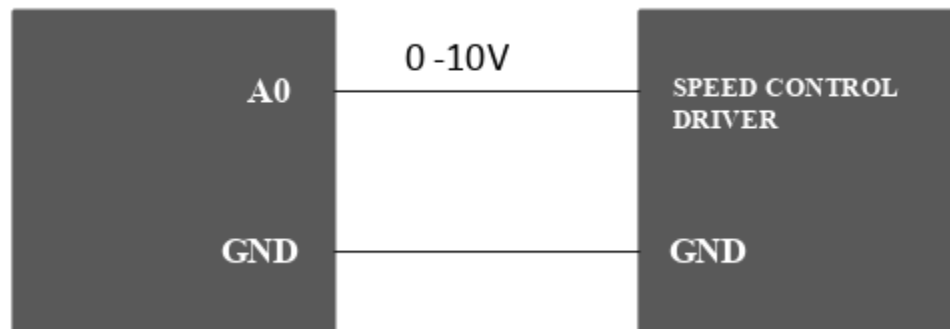

2. Interfacing DAC with Motor Speed Control Module using Loop Current

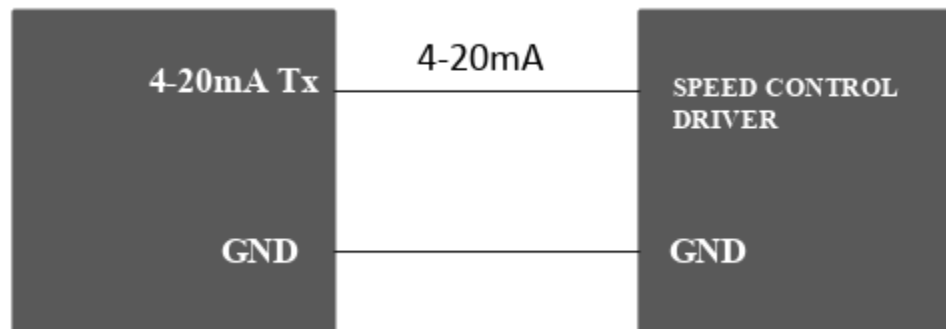



Use Case

1. Motion Control

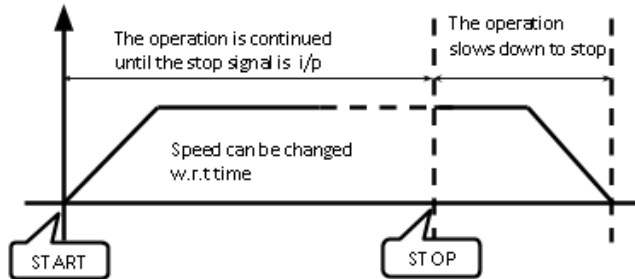

2. Acceleration and Deceleration

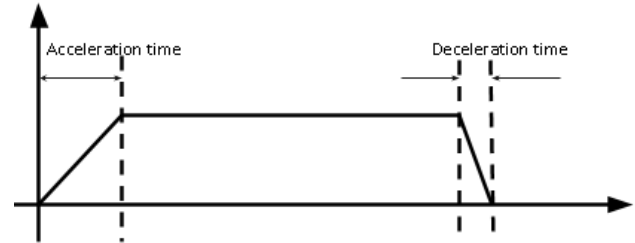

3. Jog Operation and Trapezoidal Control Operation

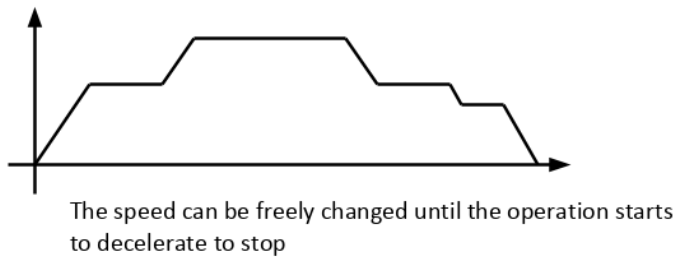

4. Measuring Frequency

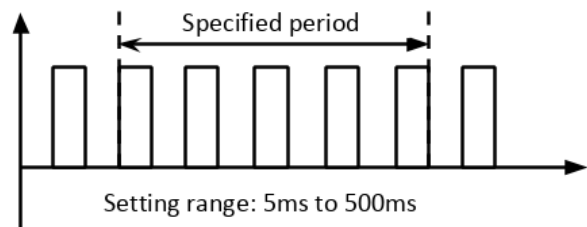

Example Code

You may look into the following link for the Arduino library and example on DAC.

<https://github.com/hideakitai/MCP4728>

8.15. Status LED Display

Status LED's can be programmed as per used needs for visual indication of an event.

Refer [Digital Output Section](#)

Functional Diagram

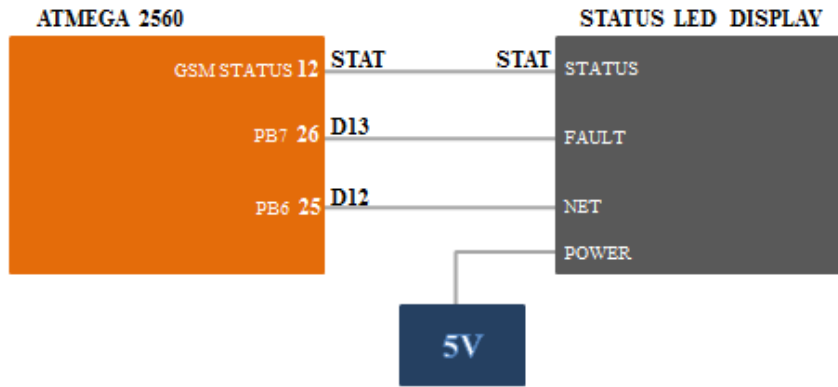

Example Code

You may look into the following link for more details on programming LED pins.

<https://www.arduino.cc/en/Reference/digitalWrite>

8.16. RDL Bus

Specification

- Extend I/O pins for communicating with external devices.
- Extends SPI pins, I2C pins, UART pins and Digital I/O pins.

Functional Diagram

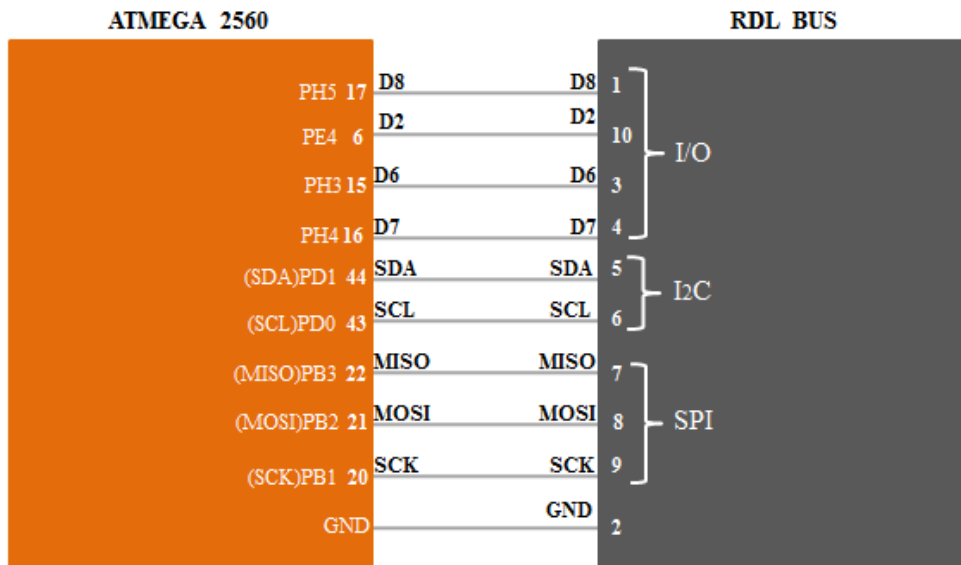



Application Wiring

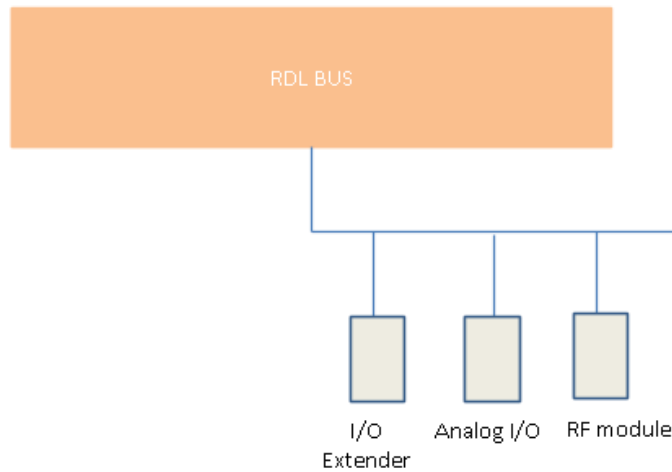

8.17. STM32

Extend I/O pins for complex controller operations so as to reduce load on AVR. For example Complex math operations can be assigned to STM32 controller by establishing physical connection with AVR controller.

Currently, some I/O pins are used for LED status indication as per commands received from AVR as shown in the figure below. But user can assign complex task on STM32 controller.

Specification

- Controller: STM32F030RCT6
- Core: ARM®32-bit Cortex®-M0 CPU with frequency 48 MHz
- 256KB flash, 32KB RAM, 51 IO pins.
- CRC calculation unit
- One 12-bit, 1.0µs ADC (up to 16 channels)
- 2 I2C, 6 USART, 2 SPI, 11 timers.



Functional Diagram

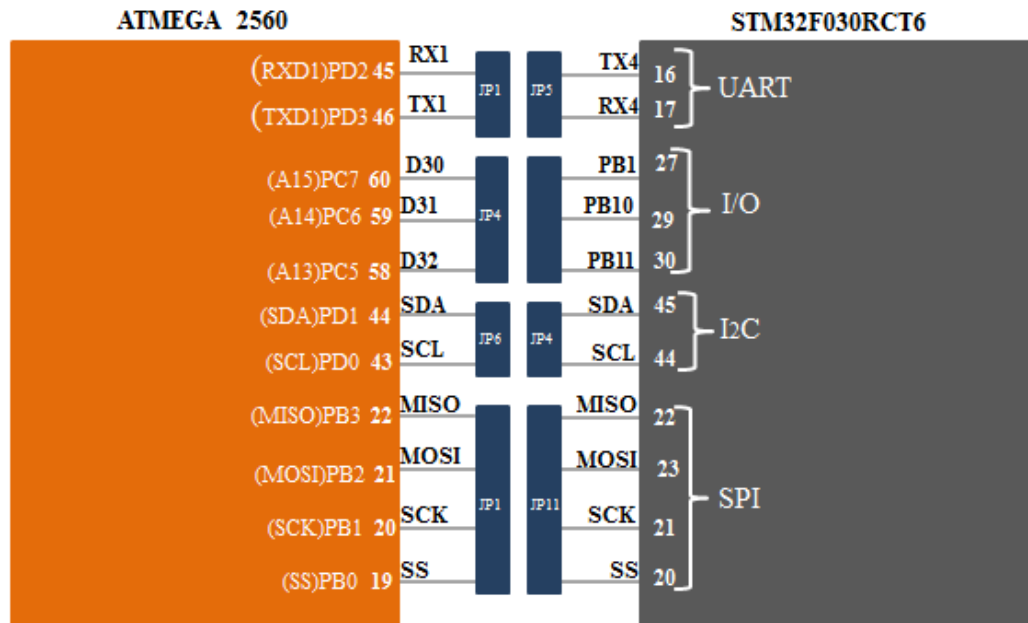



Application Diagram

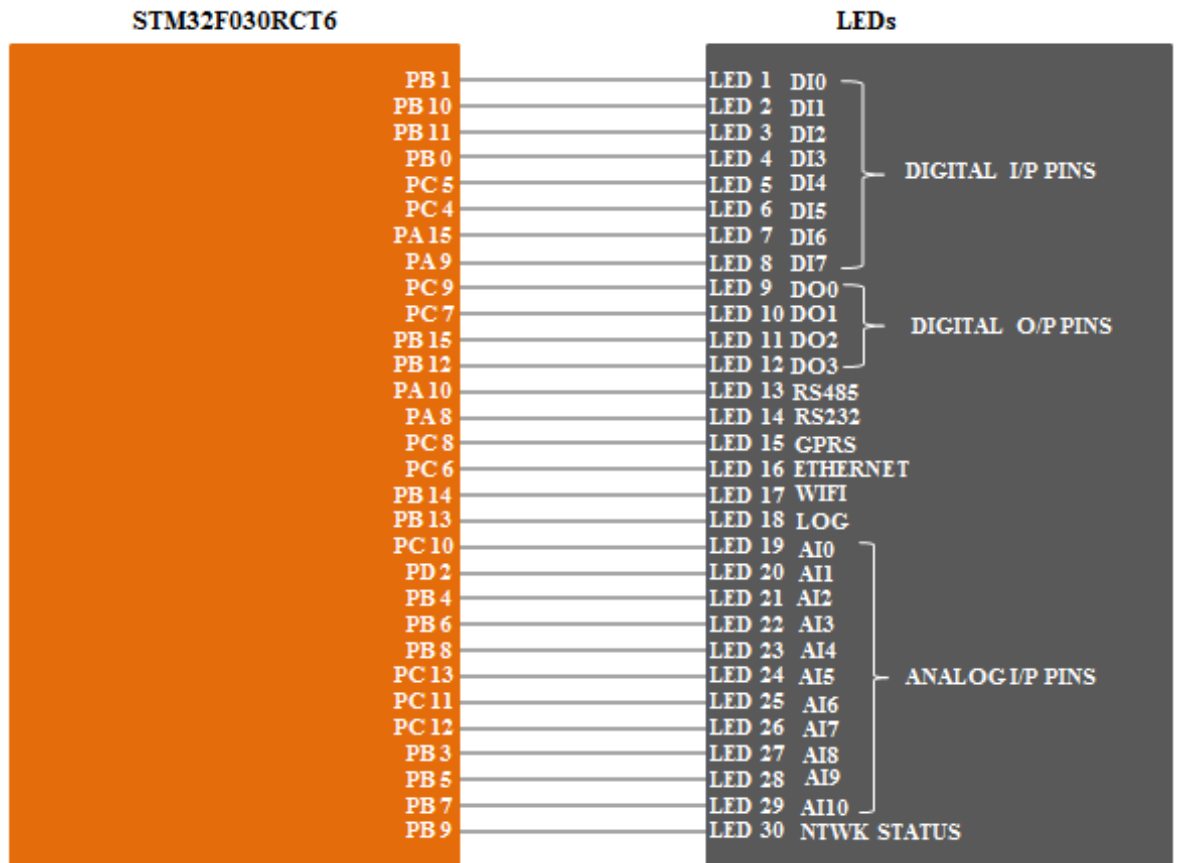



9. Order Information Table

Table-I:

Model	RDL7000	RDL7001	RDL7002	RDL7003	RDL7004	RDL7005	RDL7006	RDL7007	RDL7008
DI	8	8	8	8	8	8	8	8	8
DO	3	3	3	3	3	3	3	3	3
ADC/4-20ma	8	8	8	8	8	8	8	8	8
DAC	x	x	x	x	x	x	3	3	3
4x20ma Tx	x	x	x	x	x	x	1	1	1
GPRS	x	x	x	x	x	1	1	1	1
Ethernet 10/100mbps	x	x	x	x	1	1	1	1	1
RS485	1	1	1	1	1	1	1	1	1
RS232	1	1	1	1	1	1	1	1	1
Wi-Fi	x	x	x	x	1	1	1	1	1
Bluetooth	x	x	x	1	x	x	x	x	x
LoRA	x	x	1	x	x	x	x	x	x
Custom	8	3	1						

Ordering Information:

Model No + Custom Configuration



Example:

RDL7008WI - It comes with all the above features listed in Table-I with Wi-Fi enabled.

RDL7008BT - It comes with all the above features listed in Table-I with Bluetooth enabled

RDL7008LO - It comes with all the above features listed in Table-I with LoRA enabled.

RDL7008RS - It comes with all the above features listed in Table-I with RS-485 bus.

RDL7008 - It comes with the only features listed in Table-I



10. References and Datasheets

1. http://ww1.microchip.com/downloads/en/DeviceDoc/Atmel-2549-8-bit-AVR-Microcontroller-ATmega640-1280-1281-2560-2561_datasheet.pdf
2. <http://www.ti.com/lit/ds/symlink/max232.pdf>
3. <http://ww1.microchip.com/downloads/en/DeviceDoc/40001441F.pdf>
4. <http://ww1.microchip.com/downloads/en/DeviceDoc/20005685A.pdf>
5. <http://www.ti.com/lit/ds/symlink/lm2576hv.pdf>
6. <https://www.vishay.com/docs/83513/tcmd1000.pdf>
7. <http://www.analog.com/media/en/technical-documentation/data-sheets/485fm.pdf>
8. <http://www.ti.com/lit/ds/symlink/lm317.pdf>
9. <http://www.ti.com/lit/ds/symlink/ads1115.pdf>
10. <http://ww1.microchip.com/downloads/en/DeviceDoc/20005045C.pdf>
11. <https://www.fujitsu.com/uk/Images/MB85RC256V-20171207.pdf>
12. <http://ww1.microchip.com/downloads/en/DeviceDoc/mic811.pdf>
13. http://wizwiki.net/wiki/lib/exe/fetch.php?media=products:w5500:w5500_ds_v106e_141230.pdf
14. <http://www.analog.com/media/en/technical-documentation/data-sheets/485fm.pdf>
15. <http://ww1.microchip.com/downloads/en/DeviceDoc/22187E.pdf>
16. <http://www.ti.com/lit/ds/symlink/xtr115.pdf>